



(43) International Publication Date
5 October 2017 (05.10.2017)

(51) International Patent Classification:

C12Q 1/68 (2006.01) C40B 30/04 (2006.01)
C12N 15/10 (2006.01) C40B 40/06 (2006.01)

(21) International Application Number:

PCT/IB2017/051778

(22) International Filing Date:

28 March 2017 (28.03.2017)

(25) Filing Language:

English

(26) Publication Language:

English

(30) Priority Data:

62/313,974 28 March 2016 (28.03.2016) US
62/359,468 7 July 2016 (07.07.2016) US
62/409,633 18 October 2016 (18.10.2016) US

(71) Applicant: **BOREAL GENOMICS, INC.** [CA/CA];
Suite 302 - 2386 East Mall, Vancouver, British Columbia
V6T 1Z3 (CA).

(72) Inventors: **MARZIALI, Andrea**; 3254 Monton Avenue,
North Vancouver, British Columbia V7R 1G3 (CA). **PEL,
Joel**; 2282 East 7th Avenue, Vancouver, British Columbia
V5N 1S7 (CA).

(81) Designated States (unless otherwise indicated, for every
kind of national protection available): AE, AG, AL, AM,

AO, AT, AU, AZ, BA, BB, BG, BH, BN, BR, BW, BY,
BZ, CA, CH, CL, CN, CO, CR, CU, CZ, DE, DJ, DK, DM,
DO, DZ, EC, EE, EG, ES, FI, GB, GD, GE, GH, GM, GT,
HN, HR, HU, ID, IL, IN, IR, IS, JP, KE, KG, KH, KN,
KP, KR, KW, KZ, LA, LC, LK, LR, LS, LU, LY, MA,
MD, ME, MG, MK, MN, MW, MX, MY, MZ, NA, NG,
NI, NO, NZ, OM, PA, PE, PG, PH, PL, PT, QA, RO, RS,
RU, RW, SA, SC, SD, SE, SG, SK, SL, SM, ST, SV, SY,
TH, TJ, TM, TN, TR, TT, TZ, UA, UG, US, UZ, VC, VN,
ZA, ZM, ZW.

(84) Designated States (unless otherwise indicated, for every
kind of regional protection available): ARIPO (BW, GH,
GM, KE, LR, LS, MW, MZ, NA, RW, SD, SL, ST, SZ,
TZ, UG, ZM, ZW), Eurasian (AM, AZ, BY, KG, KZ, RU,
TJ, TM), European (AL, AT, BE, BG, CH, CY, CZ, DE,
DK, EE, ES, FI, FR, GB, GR, HR, HU, IE, IS, IT, LT, LU,
LV, MC, MK, MT, NL, NO, PL, PT, RO, RS, SE, SI, SK,
SM, TR), OAPI (BF, BJ, CF, CG, CI, CM, GA, GN, GQ,
GW, KM, ML, MR, NE, SN, TD, TG).

Published:

- with international search report (Art. 21(3))
- with sequence listing part of description (Rule 5.2(a))

(54) Title: LINKED DUPLEX FRAGMENT SEQUENCING

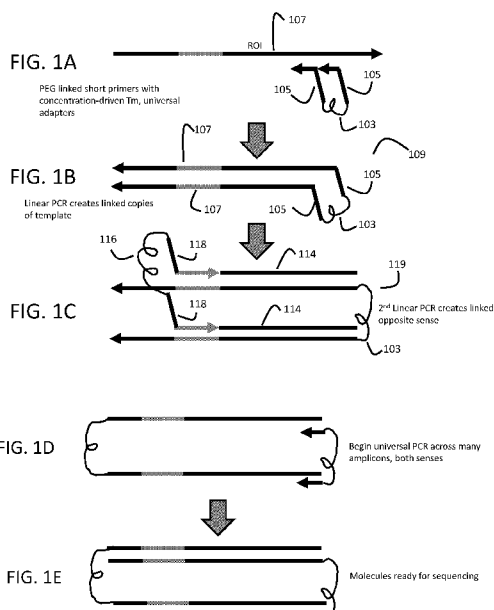

(57) Abstract: The invention generally relates to sequencing library preparation methods. In certain embodiments, two or more template nucleic acids are joined together by a linking molecule, such as a PEG derivative. Identical copies of a nucleic acid fragment or both strands of a duplex fragment may be linked together. The linked nucleic acids are amplified, creating linked amplicons. Emulsion PCR with linked primers creates linked template nucleic acids for seeding sequencing clusters and errors can be readily identified by their presence on only one of the linked fragments.



LINKED-FRAGMENT SEQUENCING

Cross-Reference to Related Applications

This application claims priority to and the benefit of U.S. Provisional Application No. 62/313,974, filed March 28, 2016, U.S. Provisional Application No. 62/359,468, filed July 7, 2016, U.S. Provisional Application No. 62/409,633, filed October 18, 2016, the contents of each of which are incorporated by reference.

Field of the invention

The invention generally relates to capturing, amplifying and sequencing nucleic acids.

Background

High-throughput genomic sequencing platforms generate large amounts of data at affordable prices, but they are not sufficiently accurate. Even the best sequencing techniques have error rates around 1 percent. That translates to hundreds of thousands of errors in the sequence of a single human genome. Inaccurate base calling leads to sequence misalignment and the misidentification of mutations. Although base calling and alignment algorithms are available, quality is negatively impacted by amplification and sequencing errors.

While advances have been made in amplification and sequencing techniques, base calling and alignment remain riddled with errors. For example, in the currently leading sequencing platform, DNA fragments are attached to a solid support, such as a channel wall. Once a fragment is attached to the solid support, the fragment is amplified and the amplification products attach to the solid support proximate to the seeding fragment. The process repeats until a cluster of amplification products that should be identical to the seeding fragments forms. However, only one fragment seeds a cluster. If there is an error in the seeding fragment or an error is made in the amplification of the cluster, the error is repeated in all or part of the cluster. This error leads to misidentifying a base and complicating sequencing alignment.

To catch these types of errors, standard barcode sequencing methods use tens to hundreds of copies of the same template, or ten to hundreds of clusters to create a sample pool for comparison. By drastically increasing the number of copies or clusters, an error can be determined. However, this strategy is expensive and consumes sequencing bandwidth.

Summary

The invention provides methods for increasing base calling accuracy by linking two or more fragments originating from the same starting template. The fragments may represent the sense and antisense strands of a duplex DNA molecule. By linking multiple templates, including, for example, both strands of the duplex molecule, into a single read, information density is increased and error rates are reduced. In duplex embodiments, the duplex data permits ready differentiation between true variants and errors introduced in amplification or sequencing (e.g., errors that a polymerase might make in one sense are not likely to be repeated in both strands while a true variant would be). Sense specific barcodes may be used to confirm the presence of both sense and antisense template copies in a cluster. Dedicated sense and antisense sequencing reads may be used to differentiate between introduced errors and true variants.

In certain embodiments, the invention provides methods of linked target capture for duplex DNA molecules. Solution-based target capture methods as well as droplet-based target capture methods are provided. The solution and droplet based methods use linked target capture probes including a universal probe and a target specific probe wherein the reactions occur under conditions that require the target specific probe to bind in order to permit binding of the universal probe. Because multiple binding and extension steps are involved, specificity is improved over traditional single binding target capture. The bound universal probe is then extended using strand displacing polymerase to produce copies of the target strands which can then be amplified using PCR with universal primers. Methods of the invention replace PCR-capture-PCR workflows with a single PCR and capture step. Linked capture probes can be used in one or both senses of DNA where higher specificity and duplex information are required. Multiple linker types are possible as discussed below. Similar to solution-based target capture methods of the invention provide for droplet based methods that allow a user to perform target capture in droplets, rather than being restricted to multiplexed PCR in droplets. Capture methods may be combined with linked primers as described herein to create linked, duplex molecules from droplets. In certain embodiments, nanoparticles comprising target capture probes as well as universal primers can be used to capture targeted regions from a pool of 5'-linked molecules, converting only the targeted molecules into duplex seeds for sequencing clusters.

Methods of the present invention have applications in sample preparation and sequencing. In sample preparation methods, the present invention allows for identical fragments

or fragments representing a sense and antisense strand of a nucleic acid to be joined together. A linking molecule joins the fragments, creating a complex. The complex can include adapters, primers, and binding molecules, in addition to the identical fragments or duplex fragments. Furthermore, in some embodiments, the complex may include multiple identical fragments linked together. In samples having low target DNA content such as prenatal samples, by linking multiple fragments together, fragments can be amplified and sequenced with increased accuracy with ready identification of sequencing and amplification errors.

Linked fragments may be created through amplification of a nucleic acid fragment with linked amplification primers. In certain embodiments, universal priming sites may be ligated onto the target fragment to create a template molecule. Methods may include droplet and non-droplet workflows and produce linked molecules representing both strands at about at least a 50% rate. In droplet amplification methods, the template molecule may be added to a droplet along with multiplex amplification primers and linked universal primers. The primers may be multiplexed gene specific forward and reverse amplification primers. The droplet can then be subjected to emulsion or digital PCR amplification. The amplified products should be linked copies of the original nucleic acid fragment or linked copies of the sense and antisense strands of an original nucleic acid fragment, depending on the application. Two or more primers or nucleic acid fragments may be linked by a polyethylene glycol derivative, an oligosaccharide, a lipid, a hydrocarbon, a polymer, or a protein. In certain embodiments, four or more biotinylated primers or nucleic acid fragments may be linked with a streptavidin molecule or a functionalized nanoparticle. Linked primers of the invention may also include unique cluster identifier sequences to ensure that all cluster reads originate from the same linked template molecule.

Methods of the present invention improve base calling when incorporated into amplification techniques. In traditional amplification methods, amplicons are created from a single template. If an error exists in the fragment, the error is propagated through the amplification products. Instead of using a single template, multiple identical templates or templates comprising the sense and antisense strands of a duplex DNA molecule are used to create the amplification products. In the event that an error develops in one of the template strands, the use of multiple templates, as opposed to a single template, allows such an error to be identified at the sequencing step. When using both strands of a duplex DNA fragment as templates, errors may be differentiated from true variants which should be found in both strands.

In certain techniques of the invention, by seeding with multiple templates, errors can be differentiated from true variants through a drop in sequencing quality in a single read at the position where the bases are not the same (a true variant would be present on all reads, providing a strong signal). In embodiments seeding a cluster with a sense and antisense strand, true variants and errors may be identified by comparing results of a first sense read to a second antisense read to confirm the presence of the variant on both template strands.

Methods of the invention may include creating linked nucleic acid fragments from a single starting molecule. By preparing linked cluster seeding complexes from a single nucleic acid fragment (e.g., using the emulsion PCR method described herein), the risk of creating hybrid complexes from two differing nucleic acid fragments is eliminated.

Additional methods relate to reducing cross talk between clusters in high density sequencing runs. Methods may include ligating two or more different adapters with different primer sequences to allow for cluster differentiation through the use of different sequencing primers corresponding to the different adapter primer sequences.

Methods of the invention include duplex identification strategies for droplet formed linked duplex molecules. As noted, droplet based methods of the invention may result in at least a 50% rate of linked duplex fragment formation (linked molecules that contain representations from each side of the DNA duplex) so, identification of those products becomes important in order to omit data from non-duplex products and reap the accuracy increasing benefits of the duplex products. Duplex identification methods may include, for example, a two-stage PCR approach using two sets of primers with different annealing temperatures where several initial cycles are performed at low temperature with gene-specific barcoding primers to amplify and identify each sense of the duplex, while adding a universal tail for subsequent cycles. The number of barcoding cycles is limited to prevent labeling each sense of the duplex with multiple barcodes. Subsequent cycles may then be performed at high temperature via universal primers because the barcoding primers are unable to bind under those conditions. Duplex products may then be identified by the presence of their sense specific barcodes during sequencing analysis and distinguished from non-duplex clusters. The higher fidelity afforded by duplex cluster seeding can therefore be appreciated.

In non-droplet embodiments, a single amplification cycle may be used to create a linked duplex molecule having both the sense and antisense strands of the original fragment. The

linked duplex molecule may then be directly loaded in a flow cell for sequencing, thereby avoiding amplification induced sequence or length biases or (e.g., in whole genome sequencing) as well as avoiding amplification introduced errors and nucleic acid losses from poor loading efficiency. For example, where loading efficiency of a sequencer can be defined as: (number of output reads)/ (number of input molecules able to form reads), the loading efficiency for the Illumina MiSeq is <0.1%, and is similar for other Illumina instruments. This is largely due to fluidic losses, since over 600uL of sample is loaded into the sequencer, while only ~7uL is retained inside the flow cell for binding, resulting in large losses of starting material. The non-droplet, direct load methods described herein remedy these inefficiencies.

For direct loading embodiments as well as other applications where the yield of flow cell loading and target capture yield are important, it may be beneficial to combine flow cell loading with targeted sequencing, to minimize loss. Such a combination additionally simplifies the workflow by eliminating an extra step. While methods exist for target capture on the flow cell, they suffer from at least two downsides. First, they are not able to sequence the region that is captured on the flow cell. For short fragments such as cell free DNA, this can amount to a large loss of signal. Secondly, they are unable to capture linked duplex molecules, as described in the invention, for sequencing. Accordingly, methods of the invention include flow cell based target capture of duplex molecules. According to methods of the invention, the flow cell contains one sense of oligos having target regions, while the other sense are hair-pinned and not immediately available for binding. After one sense of linked molecules is captured on the flow cell, the other flow cell oligos are activated to capture the other sense of the linked fragments (e.g., using a uracil digest, enzyme digestion, or light). The template may then be extended and cluster generation may continue as normal.

Methods of the present invention improve amplification on a solid support, such as in the Illumina platform (Illumina, Inc. San Diego, CA) or the Ion Torrent platform (Thermo Fisher Scientific Inc., Waltham, MA). In the Illumina technique, using bridge amplification, clusters of amplicons are formed. If an error exists in the fragment, the error is repeated in the cluster. However, with the present invention, linked fragments are contacted to the solid support. The fragments, which may be identical or represent each strand of a duplex DNA molecule, seed the cluster, resulting in a fraction of the total amplicons being derived from each of the fragments. This technique allows for an error to be readily determined at the sequencing step and can aid in

calling true variants and differentiating them from sequencing or amplification (e.g., PCR) errors.

Methods of the invention improve multiplexing amplification processes. In some embodiments of the present invention, linked fragments can be formed in or introduced into a droplet for subsequent amplification. If an error exists in some of the fragments, the error is determinable with the raw sequencing data. In some embodiments, the linked fragments can be bound to a microsphere and then with amplification, the fragments seed the microsphere with amplicons. By providing the advantage of forming a plurality of amplicons using multiple copies of the same fragment, the present invention improves base calling in a variety of applications.

Methods of the invention can be incorporated into multiple sequencing platforms. For example, in traditional sequencing by synthesis, each base is determined sequentially. An error is not determined until bioinformatics techniques are used to analyze the data. However, the present invention allows for multiple fragments of nucleic acids to be linked together during sequencing methodologies. By analyzing multiple fragments simultaneously, agreement between the bases indicates accuracy, while disagreement between the bases would signal an error. With the present invention, errors are determinable from the raw sequencing data, without the application of bioinformatics. This technique uses fewer copies or clusters, increases sequencing throughput, and decreases costs.

Brief Description of the Figures

FIGS. 1A-1E depict the process of forming the linked fragments.

FIG. 2 depicts the linked templates attached to a solid support.

FIG. 3 depicts an example of linked fragments.

FIGS. 4A-4C depict extending and amplification of the linked fragments.

FIGS. 5A-5C depict error determination in the linked fragments.

FIG. 6 depicts adapters and primers.

FIG. 7 depicts a process for the creation of linked nucleic acid fragments through emulsion PCR.

FIG. 8 depicts the creation of four linked fragments in emulsion PCR and flow cell hybridization of the four linked fragments to seed sequencing clusters.

FIG. 9 depicts ligation adapters according to certain embodiments of the invention.

FIG. 10 depicts digital PCR primers according to certain embodiments of the invention.

FIG. 11 depicts a process for the creation of linked nucleic acid fragments on a bead through emulsion PCR.

FIG. 12 depicts Ion Torrent sequencing of linked nucleic acid beads according to embodiments of the invention.

FIG. 13 depicts a process for creating linked nucleic acid fragments with different adapters and sequencing primer sites.

FIG. 14 depicts a process for sequencing clusters having different sequencing primer sites to reduce cross talk.

FIG. 15 illustrates cross talk across sequencing clusters.

FIG. 16 illustrates a droplet based method of the invention for creating linked duplex nucleic acids.

FIG. 17 depicts an exemplary linked primer and forward and reverse gene specific primers and their use according to one method of the invention.

FIG. 18 depicts an exemplary linked primer and forward and reverse gene specific primers and their use according to one method of the invention.

FIG. 19 shows gene specific primers of the invention.

FIG. 20 depicts a sequencing method of the invention with products methods shown in FIG. 17.

FIG. 21 depicts a sequencing method of the invention with products methods shown in FIG. 18.

FIGS. 22A and 22B show a non-droplet linked duplex formation method using one linking adapter.

FIGS. 23A and 23B show a non-droplet linked duplex formation method using two linking adapters.

FIGS. 24A and 24B illustrate steps of a direct loading sequencing method using linked duplex molecules.

FIG. 25 shows exemplary steps of a flow cell binding method.

FIG. 26 depicts an exemplary off-line flow cell preparation protocol.

FIG. 27 illustrates flow cell based target capture methods for duplex molecules

FIGS. 28A-28E depict steps in an exemplary flow cell based target capture and sequencing method for duplex molecules.

FIGS. 29A-29D illustrate duplex identification methods according to certain embodiments.

FIG. 30 shows sequencing error rates using singly seeded clusters that aligned to a KRAS amplicon.

FIG. 31 depicts a singly seeded cluster for sequencing methods used to produce the results shown in FIG. 30 and a double seeded cluster for sequencing methods used to produce the results shown in FIG. 43.

FIG. 32 illustrates a base calling method of the invention based on a single sequencing read and signal quality.

FIG. 33 shows a base calling method based on a comparison of a sense and antisense sequencing read.

FIG. 34 illustrates exemplary methods of linked target capture of duplex nucleic acids.

FIG. 35 illustrates amplification methods of linked target captured nucleic acids.

FIG. 36 shows methods of droplet based target capture and linked duplex nucleic acid production.

FIGS. 37A and B show steps of a droplet-based target capture method of the invention.

FIG. 38 shows a nanoparticle having universal primers and a strand comprising a target region complementary to a capture region of the linked molecule to be captured.

FIG. 39 illustrates binding of the capture region to the target region.

FIG. 40 shows binding of the universal primers to universal primer sites on the linked molecule.

FIG. 41 shows universal primer extension by strand displacing polymerase to produce nanoparticle linked copies of the target molecule comprising both strands of the original linked molecule.

FIG. 42 shows a doubly seeded nanoparticle that may be used to seed a cluster on a flow cell sequencer as described elsewhere in the application.

FIG. 43 shows sequencing error rates using doubly seeded clusters that aligned to a KRAS amplicon.

Detailed Description

The invention generally relates to methods for amplifying and sequencing nucleic acids by joining two nucleic acid fragments. These fragments may be two identical copies of a single fragment or both strands of a duplex nucleic acid. The use of two fragments reduces error rates, increases efficiency in alignment, and reduces sequencing costs.

Nucleic acid generally is acquired from a sample or a subject. Target molecules for labeling and/or detection according to the methods of the invention include, but are not limited to, genetic and proteomic material, such as DNA, genomic DNA, RNA, expressed RNA and/or chromosome(s). Methods of the invention are applicable to DNA from whole cells or to portions of genetic or proteomic material obtained from one or more cells. Methods of the invention allow for DNA or RNA to be obtained from non-cellular sources, such as viruses. For a subject, the sample may be obtained in any clinically acceptable manner, and the nucleic acid templates are extracted from the sample by methods known in the art. Generally, nucleic acid can be extracted from a biological sample by a variety of techniques such as those described by Maniatis, et al. (Molecular Cloning: A Laboratory Manual, Cold Spring Harbor, N.Y., pp. 280-281, 1982), the contents of which are incorporated by reference herein in their entirety.

Nucleic acid templates include deoxyribonucleic acid (DNA) and/or ribonucleic acid (RNA). Nucleic acid templates can be synthetic or derived from naturally occurring sources. Nucleic acids may be obtained from any source or sample, whether biological, environmental, physical or synthetic. In one embodiment, nucleic acid templates are isolated from a sample containing a variety of other components, such as proteins, lipids and non-template nucleic acids. Nucleic acid templates can be obtained from any cellular material, obtained from an animal, plant, bacterium, fungus, or any other cellular organism. Samples for use in the present invention include viruses, viral particles or preparations. Nucleic acid may also be acquired from a microorganism, such as a bacteria or fungus, from a sample, such as an environmental sample.

In the present invention, the target material is any nucleic acid, including DNA, RNA, cDNA, PNA, LNA and others that are contained within a sample. Nucleic acid molecules include deoxyribonucleic acid (DNA) and/or ribonucleic acid (RNA). Nucleic acid molecules can be synthetic or derived from naturally occurring sources. In one embodiment, nucleic acid molecules are isolated from a biological sample containing a variety of other components, such as proteins, lipids and non-template nucleic acids. Nucleic acid template molecules can be

obtained from any cellular material, obtained from an animal, plant, bacterium, fungus, or any other cellular organism. In certain embodiments, the nucleic acid molecules are obtained from a single cell. Biological samples for use in the present invention include viral particles or preparations. Nucleic acid molecules can be obtained directly from an organism or from a biological sample obtained from an organism, e.g., from blood, urine, cerebrospinal fluid, seminal fluid, saliva, sputum, stool and tissue. Any tissue or body fluid specimen may be used as a source for nucleic acid for use in the invention. Nucleic acid molecules can also be isolated from cultured cells, such as a primary cell culture or a cell line. The cells or tissues from which template nucleic acids are obtained can be infected with a virus or other intracellular pathogen. In addition, nucleic acids can be obtained from non-cellular or non-tissue samples, such as viral samples, or environmental samples.

A sample can also be total RNA extracted from a biological specimen, a cDNA library, viral, or genomic DNA. In certain embodiments, the nucleic acid molecules are bound as to other target molecules such as proteins, enzymes, substrates, antibodies, binding agents, beads, small molecules, peptides, or any other molecule and serve as a surrogate for quantifying and / or detecting the target molecule. Generally, nucleic acid can be extracted from a biological sample by a variety of techniques such as those described by Sambrook and Russell, *Molecular Cloning: A Laboratory Manual*, Third Edition, Cold Spring Harbor, N.Y. (2001). Nucleic acid molecules may be single-stranded, double-stranded, or double-stranded with single-stranded regions (for example, stem- and loop-structures). Proteins or portions of proteins (amino acid polymers) that can bind to high affinity binding moieties, such as antibodies or aptamers, are target molecules for oligonucleotide labeling, for example, in droplets.

Nucleic acid templates can be obtained directly from an organism or from a biological sample obtained from an organism, e.g., from blood, urine, cerebrospinal fluid, seminal fluid, saliva, sputum, stool and tissue. In a particular embodiment, nucleic acid is obtained from fresh frozen plasma (FFP). In a particular embodiment, nucleic acid is obtained from formalin-fixed, paraffin-embedded (FFPE) tissues. Any tissue or body fluid specimen may be used as a source for nucleic acid for use in the invention. Nucleic acid templates can also be isolated from cultured cells, such as a primary cell culture or a cell line. The cells or tissues from which template nucleic acids are obtained can be infected with a virus or other intracellular pathogen. A

sample can also be total RNA extracted from a biological specimen, a cDNA library, viral, or genomic DNA.

A biological sample may be homogenized or fractionated in the presence of a detergent or surfactant. The concentration of the detergent in the buffer may be about 0.05% to about 10.0%. The concentration of the detergent can be up to an amount where the detergent remains soluble in the solution. In a preferred embodiment, the concentration of the detergent is between 0.1% to about 2%. The detergent, particularly a mild one that is non-denaturing, can act to solubilize the sample. Detergents may be ionic or nonionic. Examples of nonionic detergents include triton, such as the Triton X series (Triton X-100 t-Oct-C₆H₄-(OCH₂-CH₂)_xOH, x=9-10, Triton X-100R, Triton X-114 x=7-8), octyl glucoside, polyoxyethylene(9)dodecyl ether, digitonin, IGEPAL CA630 octylphenyl polyethylene glycol, n-octyl-beta-D-glucopyranoside (betaOG), n-dodecyl-beta, Tween 20 polyethylene glycol sorbitan monolaurate, Tween 80 polyethylene glycol sorbitan monooleate, polidocanol, n-dodecyl beta-D-maltoside (DDM), NP-40 nonylphenyl polyethylene glycol, C12E8 (octaethylene glycol n-dodecyl monoether), hexaethyleneglycol mono-n-tetradecyl ether (C14EO6), octyl-beta-thioglucopyranoside (octyl thioglucoside, OTG), Emulgen, and polyoxyethylene 10 lauryl ether (C12E10). Examples of ionic detergents (anionic or cationic) include deoxycholate, sodium dodecyl sulfate (SDS), N-lauroylsarcosine, and cetyltrimethylammoniumbromide (CTAB). A zwitterionic reagent may also be used in the purification schemes of the present invention, such as Chaps, zwitterion 3-14, and 3-[(3-cholamidopropyl)dimethylammonio]-1-propanesulf-onate. It is contemplated also that urea may be added with or without another detergent or surfactant.

Lysis or homogenization solutions may further contain other agents, such as reducing agents. Examples of such reducing agents include dithiothreitol (DTT), beta.-mercaptoethanol, DTE, GSH, cysteine, cysteamine, tricarboxyethyl phosphine (TCEP), or salts of sulfurous acid. Once obtained, the nucleic acid is denatured by any method known in the art to produce single stranded nucleic acid templates and a pair of first and second oligonucleotides is hybridized to the single stranded nucleic acid template such that the first and second oligonucleotides flank a target region on the template.

In some embodiments, nucleic acids may be fragmented or broken into smaller nucleic acid fragments. Nucleic acids, including genomic nucleic acids, can be fragmented using any of a variety of methods, such as mechanical fragmenting, chemical fragmenting, and enzymatic

fragmenting. Methods of nucleic acid fragmentation are known in the art and include, but are not limited to, DNase digestion, sonication, mechanical shearing, and the like (J. Sambrook et al., "Molecular Cloning: A Laboratory Manual", 1989, 2.sup.nd Ed., Cold Spring Harbour Laboratory Press: New York, N.Y.; P. Tijssen, "Hybridization with Nucleic Acid Probes-- Laboratory Techniques in Biochemistry and Molecular Biology (Parts I and II)", 1993, Elsevier; C. P. Ordahl et al., *Nucleic Acids Res.*, 1976, 3: 2985-2999; P. J. Oefner et al., *Nucleic Acids Res.*, 1996, 24: 3879-3889; Y. R. Thorstenson et al., *Genome Res.*, 1998, 8: 848-855). U.S. Patent Publication 2005/0112590 provides a general overview of various methods of fragmenting known in the art.

Genomic nucleic acids can be fragmented into uniform fragments or randomly fragmented. In certain aspects, nucleic acids are fragmented to form fragments having a fragment length of about 5 kilobases or 100 kilobases. In a preferred embodiment, the genomic nucleic acid fragments can range from 1 kilobases to 20 kilobases. Preferred fragments can vary in size and have an average fragment length of about 10 kilobases. However, desired fragment length and ranges of fragment lengths can be adjusted depending on the type of nucleic acid targets one seeks to capture. The particular method of fragmenting is selected to achieve the desired fragment length. A few non-limiting examples are provided below.

Chemical fragmentation of genomic nucleic acids can be achieved using a number of different methods. For example, hydrolysis reactions including base and acid hydrolysis are common techniques used to fragment nucleic acid. Hydrolysis is facilitated by temperature increases, depending upon the desired extent of hydrolysis. Fragmentation can be accomplished by altering temperature and pH as described below. The benefit of pH-based hydrolysis for shearing is that it can result in single-stranded products. Additionally, temperature can be used with certain buffer systems (e.g. Tris) to temporarily shift the pH up or down from neutral to accomplish the hydrolysis, then back to neutral for long-term storage etc. Both pH and temperature can be modulated to affect differing amounts of shearing (and therefore varying length distributions).

Other methods of hydrolytic fragmenting of nucleic acids include alkaline hydrolysis, formalin fixation, hydrolysis by metal complexes (e.g., porphyrins), and/or hydrolysis by hydroxyl radicals. RNA shears under alkaline conditions, see, e.g. Nordhoff et al., *Nucl. Acid. Res.*, 21 (15):3347-57 (2003), whereas DNA can be sheared in the presence of strong acids.

An exemplary acid/base hydrolysis protocol for producing genomic nucleic acid fragments is described in Sargent et al. (1988) *Methods Enzymol.*, 152:432. Briefly, 1 g of purified DNA is dissolved in 50 mL 0.1 N NaOH. 1.5 mL concentrated HCl is added and the solution is mixed quickly. DNA will precipitate immediately, and should not be stirred for more than a few seconds to prevent formation of a large aggregate. The sample is incubated at room temperature for 20 minutes to partially depurinate the DNA. Subsequently, 2 mL 10 N NaOH (OH⁻ concentration to 0.1 N) is added, and the sample is stirred until the DNA re-dissolves completely. The sample is then incubated at 65 degrees C for 30 minutes in order to hydrolyze the DNA. Resulting fragments typically range from about 250-1000 nucleotides but can vary lower or higher depending on the conditions of hydrolysis.

In one embodiment, after genomic nucleic acid has been purified, it is re-suspended in a Tris-based buffer at a pH between 7.5 and 8.0, such as Qiagen's DNA hydrating solution. The re-suspended genomic nucleic acid is then heated to 65C and incubated overnight. Heating shifts the pH of the buffer into the low- to mid- 6 range, which leads to acid hydrolysis. Over time, the acid hydrolysis causes the genomic nucleic acid to fragment into single-stranded and/or double-stranded products.

Chemical cleavage can also be specific. For example, selected nucleic acid molecules can be cleaved via alkylation, particularly phosphorothioate-modified nucleic acid molecules (see, e.g., K. A. Browne, "Metal ion-catalyzed nucleic Acid alkylation and fragmentation," *J. Am. Chem. Soc.* 124(27):7950-7962 (2002)). Alkylation at the phosphorothioate modification renders the nucleic acid molecule susceptible to cleavage at the modification site. See I. G. Gut and S. Beck, "A procedure for selective DNA alkylation and detection by mass spectrometry," *Nucl. Acids Res.* 23(8):1367-1373 (1995).

Methods of the invention also contemplate chemically shearing nucleic acids using the technique disclosed in Maxam-Gilbert Sequencing Method (Chemical or Cleavage Method), *Proc. Natl. Acad. Sci. USA.* 74:560-564. In that protocol, the genomic nucleic acid can be chemically cleaved by exposure to chemicals designed to fragment the nucleic acid at specific bases, such as preferential cleaving at guanine, at adenine, at cytosine and thymine, and at cytosine alone.

Mechanical shearing of nucleic acids into fragments can occur using any method known in the art. For example, fragmenting nucleic acids can be accomplished by hydroshearing,

trituration through a needle, and sonication. See, for example, Quail, et al. (Nov 2010) DNA: Mechanical Breakage. In: eLS. John Wiley & Sons, Chichester.
doi:10.1002/9780470015902.a0005333.pub2.

The nucleic acid can also be sheared via nebulization, see (Roe, BA, Crabtree. JS and Khan, AS 1996); Sambrook & Russell, Cold Spring Harb Protoc 2006. Nebulizing involves collecting fragmented DNA from a mist created by forcing a nucleic acid solution through a small hole in a nebulizer. The size of the fragments obtained by nebulization is determined chiefly by the speed at which the DNA solution passes through the hole, altering the pressure of the gas blowing through the nebulizer, the viscosity of the solution, and the temperature. The resulting DNA fragments are distributed over a narrow range of sizes (700-1330 bp). Shearing of nucleic acids can be accomplished by passing obtained nucleic acids through the narrow capillary or orifice (Oefner et al., Nucleic Acids Res. 1996; Thorstenson et al., Genome Res. 1995). This technique is based on point-sink hydrodynamics that result when a nucleic acid sample is forced through a small hole by a syringe pump.

In HydroShearing (Genomic Solutions, Ann Arbor, Mich., USA), DNA in solution is passed through a tube with an abrupt contraction. As it approaches the contraction, the fluid accelerates to maintain the volumetric flow rate through the smaller area of the contraction. During this acceleration, drag forces stretch the DNA until it snaps. The DNA fragments until the pieces are too short for the shearing forces to break the chemical bonds. The flow rate of the fluid and the size of the contraction determine the final DNA fragment sizes.

Sonication is also used to fragment nucleic acids by subjecting the nucleic acid to brief periods of sonication, i.e. ultrasound energy. A method of shearing nucleic acids into fragments by sonification is described in U.S. Patent Publication 2009/0233814. In the method, a purified nucleic acid is obtained placed in a suspension having particles disposed within. The suspension of the sample and the particles are then sonicated into nucleic acid fragments.

An acoustic-based system that can be used to fragment DNA is described in U.S. Pat. Nos. 6,719,449, and 6,948,843 manufactured by Covaris Inc. U.S. Pat. No. 6,235,501 describes a mechanical focusing acoustic sonication method of producing high molecular weight DNA fragments by application of rapidly oscillating reciprocal mechanical energy in the presence of a liquid medium in a closed container, which may be used to mechanically fragment the DNA.

Another method of shearing nucleic acids into fragments uses ultrasound energy to produce gaseous cavitation in liquids, such as shearing with Diagonnode's BioRuptor (electrical shearing device, commercially available by Diagenode, Inc.). Cavitation is the formation of small bubbles of dissolved gases or vapors due to the alteration of pressure in liquids. These bubbles are capable of resonance vibration and produce vigorous eddying or microstreaming. The resulting mechanical stress can lead to shearing the nucleic acid into fragments.

Enzymatic fragmenting, also known as enzymatic cleavage, cuts nucleic acids into fragments using enzymes, such as endonucleases, exonucleases, ribozymes, and DNazymes. Such enzymes are widely known and are available commercially, see Sambrook, J. *Molecular Cloning: A Laboratory Manual*, 3rd (2001) and Roberts RJ (January 1980). "Restriction and modification enzymes and their recognition sequences," *Nucleic Acids Res.* 8 (1): r63-r80. Varying enzymatic fragmenting techniques are well-known in the art, and such techniques are frequently used to fragment a nucleic acid for sequencing, for example, Alazard et al, 2002; Bentzley et al, 1998; Bentzley et al, 1996; Faulstich et al, 1997; Glover et al, 1995; Kirpekar et al, 1994; Owens et al, 1998; Pielek et al, 1993; Schuette et al, 1995; Smirnov et al, 1996; Wu & Aboleneen, 2001; Wu et al, 1998a.

The most common enzymes used to fragment nucleic acids are endonucleases. The endonucleases can be specific for either a double-stranded or a single stranded nucleic acid molecule. The cleavage of the nucleic acid molecule can occur randomly within the nucleic acid molecule or can cleave at specific sequences of the nucleic acid molecule. Specific fragmentation of the nucleic acid molecule can be accomplished using one or more enzymes in sequential reactions or contemporaneously.

Restriction endonucleases recognize specific sequences within double-stranded nucleic acids and generally cleave both strands either within or close to the recognition site in order to fragment the nucleic acid. Naturally occurring restriction endonucleases are categorized into four groups (Types I, II, III, and IV) based on their composition and enzyme cofactor requirements, the nature of their target sequence, and the position of their DNA cleavage site relative to the target sequence. Bickle TA, Krüger DH (June 1993), "Biology of DNA restriction," *Microbiol. Rev.* 57 (2): 434-50; Boyer HW (1971). "DNA restriction and modification mechanisms in bacteria". *Annu. Rev. Microbiol.* 25: 153-76; Yuan R (1981). "Structure and mechanism of multifunctional restriction endonucleases". *Annu. Rev. Biochem.* 50: 285-319. All types of

enzymes recognize specific short DNA sequences and carry out the endonucleolytic cleavage of DNA to give specific fragments with terminal 5'-phosphates. The enzymes differ in their recognition sequence, subunit composition, cleavage position, and cofactor requirements. Williams RJ (2003). "Restriction endonucleases: classification, properties, and applications". *Mol. Biotechnol.* 23 (3): 225–43.

Where restriction endonucleases recognize specific sequencings in double-stranded nucleic acids and generally cleave both strands, nicking endonucleases are capable of cleaving only one of the strands of the nucleic acid into a fragment. Nicking enzymes used to fragment nucleic acids can be naturally occurring or genetically engineered from restriction enzymes. See Chan et al., *Nucl. Acids Res.* (2011) 39 (1): 1-18.

In some embodiments, DNA is sheared in biological processes within an organism, or a biological medium. Such DNA, or cell-free DNA, circulates freely in the blood stream. For example, cell-free fetal DNA (cffDNA) is fetal DNA that circulates freely in the maternal blood stream. Cell-free tumor DNA (ctDNA) is tumor DNA that circulates freely in the blood stream. Some embodiments use fragmented or sheared DNA, however, the DNA is obtained in fragmented form.

In preferred embodiments of the present invention, the nucleic acid fragments are joined together in a complex, for example, see FIG. 3 for identical fragments and FIG. 16 for two strands of duplex nucleic acid. Any linking molecule may be used to join the molecules. The linker used in the present invention may be synthesized or obtained commercially from various companies, for example, Integrated DNA Technologies, Inc., Gene Link, Inc., and TriLink Biotechnologies, Inc. The linker may be any molecule to join two primers or two nucleic acid fragments. The linking molecule may also join multiple fragments together. Any number of fragments may be incorporated to the complex.

In certain embodiments, the linking molecule may be a streptavidin molecule and the fragments to be linked may comprise biotinylated nucleic acid. In embodiments where linked primers are used to create the linked nucleic acid fragments through amplification, the primers may be biotinylated and joined together on a streptavidin molecule. For example, 4 fragments may be joined together on a tetramer streptavidin. More than four molecules could be joined through the formation of concatemers, for example. In certain methods of the invention, two or more nucleic acid fragments may be linked through click chemistry reactions. See Kolb, et al.,

Click Chemistry: Diverse Chemical Function from a Few Good Reactions, *Angew Chem Int Ed Engl.* 2001 Jun 1;40(11):2004-2021, incorporated herein by reference.

Linking molecules, for example and of several known nanoparticles, may link large numbers of fragments including hundreds or thousands of fragments in a single linked molecule. One example of a linking nanoparticle may be polyvalent DNA gold nanoparticles comprising colloidal gold modified with thiol capped synthetic DNA sequences on their surface. See, Mirkin, et al., 1996, A DNA-based method for rationally assembling nanoparticles into macroscopic materials, *Nature*, 382:607-609, incorporated herein by reference. The surface DNA sequences may be complimentary to the desired template molecule sequences or may comprise universal primers.

The linking molecule may also serve to separate the nucleic acid fragments. In preferred embodiments, the fragments are oriented to prevent binding there between. With the linker creating spatial separation and orientation of the fragments controlled, collapsing or binding between the fragments can be avoided and prevented.

In some embodiments the linkers may be polyethylene glycol (PEG) or a modified PEG. A modified PEG, such as DBCO-PEG₄, or PEG-11 may be used to join the two adapters or nucleic acids. In another example, N-hydroxysuccinimide (NHS) modified PEG is used to join the two adapters. See Schlingman, et al., *Colloids and Surfaces B: Biointerfaces* 83 (2011) 91-95. Any oligonucleotide or other molecule may be used to join adapters or nucleic acids.

In some embodiments, aptamers are used to bind two adapters or nucleic acids. Aptamers can be designed to bind to various molecular targets, such as primers or nucleic acids. Aptamers may be designed or selected by the SELEX (systematic evolution of ligands by exponential enrichment) method. Aptamers are nucleic acid macromolecules that specifically bind to target molecules. Like all nucleic acids, a particular nucleic acid ligand, i.e., an aptamer, may be described by a linear sequence of nucleotides (A, U, T, C and G), typically 15-40 nucleotides long. In some preferred embodiments, the aptamers may include inverted bases or modified bases. In some embodiments, aptamers or modified aptamers, include at least one inverted base or modified base.

It should be appreciated that the linker may be composed of inverted bases, or comprise at least one inverted base. Inverted bases or modified bases may be acquired through any commercial entity. Inverted bases or modified bases are developed and commercially available.

Inverted bases or modified bases may be incorporated into other molecules. For example, 2-Aminopurine can be substituted in an oligonucleotide. 2-Aminopurine is a fluorescent base that is useful as a probe for monitoring the structure and dynamics of DNA. 2,6-Diaminopurine (2-Amino-dA) is a modified base can form three hydrogen bonds when base-paired with dT and can increase the T_m of short oligos. 5-Bromo-deoxyuridine is a photoreactive halogenated base that can be incorporated into oligonucleotides to crosslink them to DNA, RNA or proteins with exposure to UV light. Other examples of inverted bases or modified bases include deoxyUridine (dU), inverted dT, dideoxycytidine (ddC), 5-methyl deoxyCytidine, or 2'-deoxyInosine (dI). It should be appreciated that any inverted or modified based can be used in linking template nucleic acids.

In preferred embodiments, the linker comprises a molecule for joining two primers or two nucleic acid fragments. The linker may be a single molecule, or a plurality of molecules. The linker may comprise a few inverted bases or modified bases, or entirely inverted bases or modified bases. The linker may comprise a both Watson-Crick bases and inverted or modified bases.

It should be appreciated that any spacer molecule or linking molecule may be used in the present invention. In some embodiments, the linker or spacer molecule may be a lipid or an oligosaccharide, or an oligosaccharide and a lipid. See US Patent 5,122,450. In this example, the molecule is preferably a lipid molecule and, more preferably, a glyceride or phosphatide which possesses at least two hydrophobic polyalkylene chains.

The linker may be composed of any number of adapters, primers, and copies of fragments. A linker may include two identical arms, where each arm is composed of binding molecules, amplification primers, sequencing primers, adapters, and fragments. A linker may link together any number of arms, such as three or four arms. It should be appreciated that in some aspects of the invention, nucleic acid templates are linked by a spacer molecule. The linker in the present invention may be any molecule or method to join two fragments or primers. In some embodiments, polyethylene glycol or a modified PEG such as DBCO-PEG₄ or PEG-11 is used. In some embodiments the linker is a lipid or a hydrocarbon. In some embodiments a protein may join the adapters or the nucleic acids. In some embodiments, an oligosaccharide links the primers or nucleic acids. In some embodiments, aptamers link the primers or nucleic

acids. When the fragments are linked, the copies are oriented to be in phase so to prevent binding there between.

In certain embodiments, a linker may be an antibody. The antibody may be a monomer, a dimer or a pentamer. It should be appreciated that any antibody for joining two primers or nucleic acids may be used. For example, it is known in the art that nucleoside can be made immunogenic by coupling to proteins. See Void, BS (1979), Nucl Acids Res 7, 193-204. In addition, antibodies may be prepared to bind to modified nucleic acids. See Biochemical Education, Vol. 12, Issue 3.

The linker may stay attached to the complex during amplification. In some embodiments, the linker is removed prior to amplification. In some embodiments, a linker is attached to a binding molecule, and the binding molecule is then attached to an amplification primer. When the linker is removed, the binding molecule or binding primer is exposed. The exposed binding molecule also attaches to a solid support and an arch is formed. The linker may be removed by any known method in the art, including washing with a solvent, applying heat, altering pH, washing with a detergent or surfactant, etc.

Methods of the invention provide for nucleic acids to be linked together with a linker molecule. In samples with low genetic material, nucleic acids can be linked together in order to ensure identical fragments or fragments comprising both strands of a duplex nucleic acid are amplified simultaneously or sequentially. Samples such as prenatal samples have low genetic content and amplifying linked fragments according to the invention increases the detectable content. This method reduces the signal to noise ratio, improving the detection of the target sequence.

Methods of the invention utilize amplification to amplify a target nucleic acid, such as a fragment, to a detectable level. It should be appreciated that any known amplification technique can be used in the present invention. Further, the amplified segments created by an amplification process may be themselves, efficient templates for subsequent amplifications.

Amplification refers to production of additional copies of a nucleic acid sequence and is generally carried out using polymerase chain reaction or other technologies well known in the art (e.g., Dieffenbach and Dveksler, PCR Primer, a Laboratory Manual, Cold Spring Harbor Press, Plainview, N.Y. [1995]). The amplification reaction may be any amplification reaction known in the art that amplifies nucleic acid molecules, such as polymerase chain reaction, nested

polymerase chain reaction, ligase chain reaction (Barany F. (1991) PNAS 88:189-193; Barany F. (1991) PCR Methods and Applications 1:5-16), ligase detection reaction (Barany F. (1991) PNAS 88:189-193), transcription based amplification system, nucleic acid sequence-based amplification, rolling circle amplification, and hyper-branched rolling circle amplification.

In some embodiments, multiple displacement amplification (MDA), a non-PCR based DNA amplification technique, rapidly amplifies minute amounts of DNA samples for genomic analysis. The reaction starts by annealing random hexamer primers to the template: DNA synthesis is carried out by a high fidelity enzyme at a constant temperature. However, it should be appreciated that any amplification method may be used with the current invention.

In certain embodiments of the invention, the amplification reaction is the polymerase chain reaction. Polymerase chain reaction (PCR) refers to methods by K. B. Mullis (U.S. patent numbers 4,683,195 and 4,683,202, hereby incorporated by reference) for increasing concentration of a segment of a target sequence in a mixture of genomic DNA without cloning or purification. The process for amplifying the target sequence includes introducing an excess of oligonucleotide primers to a DNA mixture containing a desired target sequence, followed by a precise sequence of thermal cycling in the presence of a DNA polymerase. The primers are complementary to their respective strands of the double stranded target sequence.

In some aspects of the invention, PCR primers are joined by a linker molecule and through the PCR process, identical copies of a fragment or both strands of a duplex fragment are linked to the primers. In other embodiments, adapters are added to the primers or copies of the fragments. The resulting complex includes, generally, two identical copies of a fragment or the sense and antisense strands of a duplex nucleic acid directly or indirectly joined by a linking molecule. It should be appreciated that one or both of the linked fragments or strands may include an error. However, there is a low probability that each will have a matching error at the exact same base. Disagreement between the two fragments at a base would indicate an error as opposed to a true variant. The base could then be identified as an unknown, just from the raw sequencing data.

Primers can be prepared by a variety of methods including but not limited to cloning of appropriate sequences and direct chemical synthesis using methods well known in the art (Narang et al., *Methods Enzymol.*, 68:90 (1979); Brown et al., *Methods Enzymol.*, 68:109 (1979)). Primers can also be obtained from commercial sources such as Operon Technologies,

Amersham Pharmacia Biotech, Sigma, and Life Technologies. The primers can have an identical melting temperature. The lengths of the primers can be extended or shortened at the 5' end or the 3' end to produce primers with desired melting temperatures. Also, the annealing position of each primer pair can be designed such that the sequence and, length of the primer pairs yield the desired melting temperature. The simplest equation for determining the melting temperature of primers smaller than 25 base pairs is the Wallace Rule ($T_d=2(A+T)+4(G+C)$). Computer programs can also be used to design primers, including but not limited to Array Designer Software (Arrayit Inc.), Oligonucleotide Probe Sequence Design Software for Genetic Analysis (Olympus Optical Co.), NetPrimer, and DNAsis from Hitachi Software Engineering. The T_M (melting or annealing temperature) of each primer is calculated using software programs such as Oligo Design, available from Invitrogen Corp.

In some embodiments, to effect amplification, a mixture is denatured and the primers then annealed to their complementary sequences within the target molecule. Following annealing, the primers are extended with a polymerase so as to form a new pair of complementary strands. The steps of denaturation, primer annealing and polymerase extension can be repeated many times (i.e., denaturation, annealing and extension constitute one cycle; there can be numerous cycles) to obtain a high concentration of an amplified segment of a desired target sequence. The length of the amplified segment of the desired target sequence is determined by relative positions of the primers with respect to each other, and therefore, this length is a controllable parameter.

In some embodiments, to create complexes of the invention, primers are linked by a linking molecule or a spacer molecule to create two linked copies of the fragment. In other embodiments, two fragments are linked together following at least one PCR step. It should be appreciated that PCR can be applied to fragments before or after the fragments are joined via a linking molecule. In some embodiments, when the fragments are joined, PCR can be implemented on the joined fragments. In some embodiments, the linked copies undergo amplification. The amplification step includes linked primers. The result is that after a cycle of PCR, linked complexes comprising copies of the fragments are produced.

With PCR, it is possible to amplify a single copy of a specific target sequence in genomic DNA to a level that can be detected by several different methodologies (e.g., staining, hybridization with a labeled probe; incorporation of biotinylated primers followed by avidin-

enzyme conjugate detection; incorporation of ^{32}P -labeled deoxynucleotide triphosphates, such as dCTP or dATP, into the amplified segment). In addition to genomic DNA, any oligonucleotide sequence can be amplified with the appropriate set of primer molecules. In particular, the amplified segments created by the PCR process itself are, themselves, efficient templates for subsequent PCR amplifications. Amplified target sequences can be used to obtain segments of DNA (e.g., genes) for insertion into recombinant vectors.

Other amplification methods and strategies can also be utilized in the present invention. For example, another approach would be to combine PCR and the ligase chain reaction (LCR). Since PCR amplifies faster than LCR and requires fewer copies of target DNA to initiate, PCR can be used as first step followed by LCR. The amplified product could then be used in a LCR or ligase detection reaction (LDR) in an allele-specific manner that would indicate if a mutation was present. Another approach is to use LCR or LDR for both amplification and allele-specific discrimination. The later reaction is advantageous in that it results in linear amplification. Thus the amount of amplified product is a reflection of the amount of target DNA in the original specimen and therefore permits quantitation.

LCR utilizes pairs of adjacent oligonucleotides which are complementary to the entire length of the target sequence (Barany F. (1991) PNAS 88:189-193; Barany F. (1991) PCR Methods and Applications 1:5-16). If the target sequence is perfectly complementary to the primers at the junction of these sequences, a DNA ligase will link the adjacent 3' and 5' terminal nucleotides forming a combined sequence. If a thermostable DNA ligase is used with thermal cycling, the combined sequence will be sequentially amplified. A single base mismatch at the junction of the oligonucleotides will preclude ligation and amplification. Thus, the process is allele-specific. Another set of oligonucleotides with 3' nucleotides specific for the mutant would be used in another reaction to identify the mutant allele. A series of standard conditions could be used to detect all possible mutations at any known site. LCR typically utilizes both strands of genomic DNA as targets for oligonucleotide hybridization with four primers, and the product is increased exponentially by repeated thermal cycling.

Amplification or sequencing adapters or barcodes, or a combination thereof, may be attached to the fragmented nucleic acid. Such molecules may be commercially obtained, such as from Integrated DNA Technologies (Coralville, IA). In certain embodiments, such sequences are attached to the template nucleic acid molecule with an enzyme such as a ligase. Suitable ligases

include T4 DNA ligase and T4 RNA ligase, available commercially from New England Biolabs (Ipswich, MA). The ligation may be blunt ended or via use of complementary overhanging ends.

In certain embodiments, following fragmentation, the ends of the fragments may be repaired, trimmed (e.g. using an exonuclease), or filled (e.g., using a polymerase and dNTPs) to form blunt ends. In some embodiments, end repair is performed to generate blunt end 5' phosphorylated nucleic acid ends using commercial kits, such as those available from Epicentre Biotechnologies (Madison, WI). Upon generating blunt ends, the ends may be treated with a polymerase and dATP to form a template independent addition to the 3'-end and the 5'-end of the fragments, thus producing a single A overhanging. This single A can guide ligation of fragments with a single T overhanging from the 5'-end in a method referred to as T-A cloning. Alternatively, because the possible combination of overhangs left by the restriction enzymes are known after a restriction digestion, the ends may be left as-is, i.e., ragged ends. In certain embodiments double stranded oligonucleotides with complementary overhanging ends are used.

In certain embodiments, one or more bar code is attached to each, any, or all of the fragments. A bar code sequence generally includes certain features that make the sequence useful in sequencing reactions. The bar code sequences are designed such that each sequence is correlated to a particular portion of nucleic acid, allowing sequence reads to be correlated back to the portion from which they came. Methods of designing sets of bar code sequences is shown for example in U.S. Pat. 6,235,475, the contents of which are incorporated by reference herein in their entirety. In certain embodiments, the bar code sequences are attached to the template nucleic acid molecule, e.g., with an enzyme. The enzyme may be a ligase or a polymerase, as discussed above. Attaching bar code sequences to nucleic acid templates is shown in U.S. Pub. 2008/0081330 and U.S. Pub. 2011/0301042, the content of each of which is incorporated by reference herein in its entirety. Methods for designing sets of bar code sequences and other methods for attaching bar code sequences are shown in U.S. Pats. 7,537,897; 6,138,077; 6,352,828; 5,636,400; 6,172,214; and 5,863,722, the content of each of which is incorporated by reference herein in its entirety. After any processing steps (e.g., obtaining, isolating, fragmenting, amplification, or barcoding), nucleic acid can be sequenced.

Exemplary methods for designing sets of barcode sequences and other methods for attaching barcode sequences are shown in U.S. patent numbers 6,138,077; 6,352,828; 5,636,400; 6,172,214; 6,235,475; 7,393,665; 7,544,473; 5,846,719; 5,695,934; 5,604,097; 6,150,516;

RE39,793; 7,537,897; 6,172,218; and 5,863,722, the content of each of which is incorporated by reference herein in its entirety.

The barcode sequence generally includes certain features that make the sequence useful in sequencing reactions. For example the barcode sequences can be designed to have minimal or no homopolymer regions, i.e., 2 or more of the same base in a row such as AA or CCC, within the barcode sequence. The barcode sequences can also be designed so that they do not overlap the target region to be sequenced or contain a sequence that is identical to the target.

The first and second barcode sequences are designed such that each pair of sequences is correlated to a particular sample, allowing samples to be distinguished and validated. Methods of designing sets of barcode sequences is shown for example in Brenner et al. (U.S. patent number 6,235,475), the contents of which are incorporated by reference herein in their entirety. In certain embodiments, the barcode sequences range from about 2 nucleotides to about 50; and preferably from about 4 to about 20 nucleotides. Since the barcode sequence is sequenced along with the template nucleic acid or may be sequenced in a separate read, the oligonucleotide length should be of minimal length so as to permit the longest read from the template nucleic acid attached. Generally, the barcode sequences are spaced from the template nucleic acid molecule by at least one base.

Methods of the invention involve attaching the barcode sequences to the template nucleic acids. Template nucleic acids are able to be fragmented or sheared to desired length, e.g. generally from 100 to 500 bases or longer, using a variety of mechanical, chemical and/or enzymatic methods. DNA may be randomly sheared via sonication, exposed to a DNase or one or more restriction enzymes, a transposase, or nicking enzyme. RNA may be fragmented by brief exposure to an RNase, heat plus magnesium, or by shearing. The RNA may be converted to cDNA before or after fragmentation.

Barcode sequence is integrated with template using methods known in the art. Barcode sequence is integrated with template using, for example, a ligase, a polymerase, Topo cloning (e.g., Invitrogen's topoisomerase vector cloning system using a topoisomerase enzyme), or chemical ligation or conjugation. The ligase may be any enzyme capable of ligating an oligonucleotide (RNA or DNA) to the template nucleic acid molecule. Suitable ligases include T4 DNA ligase and T4 RNA ligase (such ligases are available commercially, from New England Biolabs). Methods for using ligases are well known in the art. The polymerase may be any

enzyme capable of adding nucleotides to the 3' and the 5' terminus of template nucleic acid molecules. Barcode sequence can be incorporated via a PCR reaction as part of the PCR primer. Regardless of the incorporation of molecular barcodes or the location of the barcodes in the event that they are incorporated, sequencing adaptors can be attached to the nucleic acid product in a bi-directional way such that in the same sequencing run there will be sequencing reads from both the 5' and 3' end of the target sequence. In some cases it is advantage to use the location of the barcode on the 5' or 3' end of the target sequence to indicate the direction of the read. It is well known to one skilled in the art how to attach the sequencing adaptors using techniques such as PCR or ligation.

FIG. 6 shows examples of possible configurations of adapter and primers. As shown at 602, a P7 primer is attached to a Read2 primer site, which is attached to a complimentary region. At 603, a linked PCR priming region is attached to a unique molecular identifier. As shown at 604, a P5 primer is attached to an index read primer site, and a seeding control site.

In some embodiments, multiple copies of a fragment are joined together. It should be appreciated that any number of fragments can be joined together, whether 2, 3, 4, etc. The joined copies may be referred to as a unit. Several units may then be joined together with a linking molecule. It should be appreciated that any number of units may be joined by a linking molecule. This increases the information density within a complex. When the complex is attached to a solid support, the complex is amplified. The amplification products may be attached to the solid support. By joining multiple copies of the fragment to the complex and then amplifying the complexes, information density on a solid support increases.

In certain embodiments, the nucleic acids may be amplified by two or more joined primers. Any known method of amplification may be used in conjunction with the linked primers. In certain embodiments, digital PCR or emulsion PCR may be used to create two or more linked nucleic acid fragments for seeding sequencing clusters or for use in other sequencing methods. In a preferred embodiment, a template nucleic acid may be created by ligating adapters to a nucleic acid fragment of interest to be sequenced. Adapters may optionally include universal priming sites, one or more sequencing primer sites, and unique cluster identifiers to ensure that all sequencing reads in a given cluster originated from the same starting template. FIG. 9 shows exemplary ligation adapters designed according to certain embodiments of the invention. For example, adapters may be used with varying stem regions such as y1:

CCTACTCGCTAC (SEQ ID No. 1), y2: ATGCGAGCCTCT (SEQ ID No. 2), y3: GCACCTCATCCA ((SEQ ID No. 3), and y4: TGCAGGATGGTG (SEQ ID No. 4). Adapter sequences may include a unique cluster identifier (UCI) which may comprise a series of random bases (e.g., 2, 3, 4, 5, or more) to distinguish between neighboring clusters on a sequencing flow cell. Adapter sequences may include a phosphorothioate-linked T in order to reduce 3' exonuclease digestion that might remove T overhang and reduce ligation efficiency. A 3' phosphate blocker is optional but not essential for digital PCR methods of the invention.

Once adapters have been ligated to the nucleic acid fragment to be sequenced, an emulsion or droplet can be created. The droplets may be aqueous droplets surrounded by an immiscible carrier fluid. Methods of forming such droplets and conducting PCR amplification within the droplets are shown for example in Link et al. (U.S. patent application numbers 2008/0014589, 2008/0003142, and 2010/0137163), Stone et al. (U.S. Pat. No. 7,708,949 and U.S. patent application number 2010/0172803), and Anderson et al. (U.S. Pat. No. 7,041,481 and which reissued as RE41,780).

In preferred embodiments, a single template nucleic acid molecule is added to a droplet in order to ensure that eventual clusters are seeded with only one template molecule and to prevent the formation of hybrid linked nucleic acid complexes containing different nucleic acid fragments. Various multiplex primers that may be gene specific are also added to the droplet along with linked primers. The linked primers may be two or more primers linked together according to any of the methods described herein. Linked primers may include, for example, universal priming sites corresponding to the universal priming sites in the ligated adapters as well as sequencing primer sites (e.g., different index priming sites to identify when more than one molecule has seeded a cluster). In certain embodiments, the linked primers may include gene specific primers targeting specific regions of interest to be sequenced such that the initial ligation step may be avoided and an unmodified nucleic acid fragment may be added directly to the droplet for linked-primer digital PCR amplification. FIG. 10 illustrates primers and ligated template nucleic acid fragments according to certain methods of the invention where the ligated template comprises a priming site corresponding to the priming site of the linked universal primers and gene specific multiplex primers are used to create linked copies of the target nucleic acid.

FIG. 7 illustrates exemplary linked-primer emulsion PCR methods of the invention. A sample nucleic acid fragment 701, such as cell-free DNA having a region of interest 724, is ligated 703 with adapters 725 to form a template molecule 730. An emulsion is then created 705 comprising a single template molecule 730, linked primers 722, and multiplex gene-specific primers 723 in a droplet 726. The template is then amplified in the droplet using known emulsion PCR methods to create linked copies of the template molecule 730 comprising sequencing primer sites, the nucleic acid region of interest 724 and any of the other optional sequences described herein. The emulsion is then broken 707 according to any known methods to release the linked copies of the template molecule. It should be noted that PCR amplification may introduce PCR errors 721 into the linked template molecules but the nature of the disclosed methods with dual copy cluster seeding is that such errors may be identified and differentiated from true variants 720 which would be present in both of the linked copies seeding a cluster. Linked template molecules 730 may then optionally be screened, purified, or enzymatically selected 709 for sequencing cluster seeding. The linked templates 730 may then be hybridized to a flow cell or otherwise sequenced 711 as described elsewhere.

As noted earlier, linked template molecules may comprise two or more copies of a nucleic acid fragment. FIG. 8 illustrates a droplet 726 used for the formation of linked template molecules or complexes comprising four fragment copies. The droplet 726 comprises complexes of four linked primers 722 with two copies of two alternating primers. Such a complex of linked primers may be formed using, for example streptavidin/biotin tetramers as described above. The droplet 726 may further comprise gene-specific multiplex primers 723 and, preferably, a single copy of the nucleic acid fragment template molecule 730 to be sequenced. The droplet may otherwise be subjected to PCR amplification in the same manner as described with respect to FIG. 7 with the alternative result of producing four linked copies of the template molecule with which to seed a cluster for sequencing and aid in identification and differentiation of legitimate, if rare, variants 720, and PCR errors 721 or other false positives.

In certain embodiments, methods of the invention relate to reducing cross talk among nearby clusters in high density sequencing runs. FIG. 15 illustrates the problem presented by cross talk where a matched base from a neighboring cluster during a sequencing read may mask a true mixed base within a single cluster. In order to reduce this cross talk, a second adapter with a different sequencing primer site can be added during ligation and a corresponding sequencing

primer is used to help differentiate between base agreement within a cluster and base agreement between neighboring clusters. While these methods may be used in any standard sequencing technique, FIGS. 13 and 14, illustrate the methods as applied to linked primer emulsion PCR and linked fragment cluster seeding. FIG. 13 shows multiple sample nucleic acid fragments 701 and 735, such as cell-free DNA having regions of interest 724 and 736 respectively, being ligated 703 with two different adapters 725 and 734 to form a first template molecule 730 and a second template molecule 733, comprising the different regions of interest 724 and 736 along with variants 720 to be characterized. Two emulsions are then created 705, each comprising one of the template molecules 730 or 733, linked primers 722, corresponding to each adapter, and multiplex gene-specific primers 723 in a droplet 726. The templates are then amplified in the droplet using known emulsion PCR methods to create linked copies of the template molecules 730 and 733 comprising different sequencing primer sites introduced by the two different adapters 725 and 734. The emulsion is then broken 707 according to any known methods to release the linked copies of the template molecules 730 and 733. It should be noted that PCR amplification may introduce PCR errors 721 into the linked template molecules but the nature of the disclosed methods with dual copy cluster seeding is that such errors may be identified as such and differentiated from variants 720 which would be present in both of the linked copies seeding a cluster. Linked template molecules 730 and 733 may then optionally be screened, purified, or enzymatically selected 709 for sequencing cluster seeding. The linked templates 730 may then be hybridized to a flow cell or otherwise sequenced 711 as described elsewhere.

As shown in FIG. 14, clusters are seeded with one of the two templates adapters 725 or 734. Exemplary steps of the sequencing method then include performing a short read using a sequencing priming site common across one sense of all the clusters; performing an index read common across the other sense of all the clusters to identify possible cluster seeding by multiple templates; performing a read on the target cluster with primers corresponding to the sequencing priming site of the second adapter 734; and then performing a long index read on the neighboring cluster with primers corresponding to the sequencing priming site of the first adapter 725. There is a 50% chance that the neighboring clusters contain the sequencing priming site of the first adapter 725 and, by using the above technique, the reads of neighboring clusters may be identified and the risk of cross talk masking mixed bases within a single cluster is reduced.

Identifying variants 720 and differentiating them from PCR errors 721, can be accomplished more reliably with the reduced crosstalk afforded by the methods of the invention.

As shown in FIG. 1A, a linker 103 comprises two short primers 105 with concentration driven T_m . The linker 103 or the primers 105 may be also attached to universal adapters (not shown). As an alternative to emulsion PCR techniques described above, linked primer amplification may be accomplished using multiple linear PCR steps. During linear PCR, two copies of the genomic template 107 are prepared. As shown in FIG. 1B, the complex 109 comprises the linker 103, the primers 105 and identical copies of the nucleic acid template 107. As shown in FIG. 1C, a second linear PCR step using a different linker 116 and adapters 118 is used to create the opposite senses 114 to nucleic acid templates 107. Complexes 109 and 119 undergo additional steps of amplification, such as universal PCR, to create multiple amplicons of both senses (the sense and anti-sense). See for FIGS. 1D and 1E.

An example complex is shown in FIG. 3. As shown in FIG. 3, a complex 301 contains a linker 301 attached to two primers 303. Complex also comprises sequence read primers 305 and adapters 307 to link to the target nucleic acid 309. The complex also comprises complimentary adapters 311 and primers 313. In a preferred embodiment, primers 313 are P7 primers and primers 303 are P5 primers. It should be appreciated that any combination, orientation or configuration of the adapters, primers, and target nucleic acids can be organized. It should also be appreciated that the complexes may include bar codes. FIG. 3 is to be an example and not a limiting embodiment.

Complexes of the invention may be attached to various solid supports such as microbeads, beads, channel walls, microchips, etc.

Sequencing the joined fragments may be by any method known in the art. The present invention has applications in various sequencing platforms, including the genome sequencers from Roche/454 Life Sciences (Margulies et al. (2005) *Nature*, 437:376-380; U.S. Pat. Nos. 6,274,320; 6,258,568; 6,210,891), the SOLiD system from Life Technologies Applied Biosystems (Grand Island, NY), the HELISCOPE system from Helicos Biosciences (Cambridge, MA) (see, e.g., U.S. Pub. 2007/0070349), and the Ion sequencers from Life Technologies Ion Torrent, Ion Torrent Systems, Inc. (Guilford, CT).

In preferred embodiments, sequencing is by methods where each base is determined sequentially. DNA sequencing techniques include classic dideoxy sequencing reactions (Sanger

method) using labeled terminators or primers and gel separation in slab or capillary, sequencing by synthesis using reversibly terminated labeled nucleotides, pyrosequencing, 454 sequencing, allele specific hybridization to a library of labeled oligonucleotide probes, sequencing by synthesis using allele specific hybridization to a library of labeled clones that is followed by ligation, real time monitoring of the incorporation of labeled nucleotides during a polymerization step, polony sequencing, and SOLiD sequencing. Sequencing of separated molecules has more recently been demonstrated by sequential or single extension reactions using polymerases or ligases as well as by single or sequential differential hybridizations with libraries of probes.

It should be appreciated that the linker may also be attached to adapters, primers, or binding molecules. The linker can be attached to these species in any orientation or arrangement. The linking molecule may be directly attached to an adapter or primer and indirectly linked to the nucleic acid fragments. In some aspects of the invention, the linking molecule is removed before or after amplification. In some embodiments, the linking molecule remains on the complex. In some embodiments, the linking molecule is removed prior to sequencing, where in other embodiments the linking molecule remains on the complex during sequencing.

A sequencing technique that can be used in the methods of the provided invention includes, for example, Helicos True Single Molecule Sequencing (tSMS) (Harris T. D. et al. (2008) *Science* 320:106-109). In the tSMS technique, a DNA sample is cleaved into strands of approximately 100 to 200 nucleotides, and a polyA sequence is added to the 3' end of each DNA strand. Each strand is labeled by the addition of a fluorescently labeled adenosine nucleotide. The DNA strands are then hybridized to a flow cell, which contains millions of oligo-T capture sites that are immobilized to the flow cell surface. The templates can be at a density of about 100 million templates/cm². The flow cell is then loaded into an instrument, e.g., HeliScope sequencer, and a laser illuminates the surface of the flow cell, revealing the position of each template. A CCD camera can map the position of the templates on the flow cell surface. The template fluorescent label is then cleaved and washed away. The sequencing reaction begins by introducing a DNA polymerase and a fluorescently labeled nucleotide. The oligo-T nucleic acid serves as a primer. The polymerase incorporates the labeled nucleotides to the primer in a template directed manner. The polymerase and unincorporated nucleotides are removed. The templates that have directed incorporation of the fluorescently labeled nucleotide are detected by imaging the flow cell surface. After imaging, a cleavage step removes the fluorescent label, and

the process is repeated with other fluorescently labeled nucleotides until the desired read length is achieved. Sequence information is collected with each nucleotide addition step. With the present invention, the linked fragments can be identified in tandem. Further description of tSMS is shown for example in Lapidus et al. (U.S. patent number 7,169,560), Lapidus et al. (U.S. patent application number 2009/0191565), Quake et al. (U.S. patent number 6,818,395), Harris (U.S. patent number 7,282,337), Quake et al. (U.S. patent application number 2002/0164629), and Braslavsky, et al., PNAS (USA), 100: 3960-3964 (2003), the contents of each of these references is incorporated by reference herein in its entirety.

Another example of a DNA sequencing technique that can be used in the methods of the provided invention is 454 sequencing (Roche) (Margulies, M et al. 2005, Nature, 437, 376-380). 454 sequencing involves two steps. In the first step, DNA is sheared into fragments of approximately 300-800 base pairs, and the fragments are blunt ended. Oligonucleotide adaptors are then ligated to the ends of the fragments. The adaptors serve as primers for amplification and sequencing of the fragments. The fragments can be attached to DNA capture beads, e.g., streptavidin-coated beads using, e.g., Adaptor B, which contains 5'-biotin tag. Using the methods of the present invention, joined fragments as described above are captured on the beads. The joined fragments attached to the beads are PCR amplified within droplets of an oil-water emulsion. The result is multiple copies of clonally amplified DNA fragments on each bead. In the second step, the beads are captured in wells (pico-liter sized). Pyrosequencing is performed on each DNA fragment in parallel. Addition of one or more nucleotides generates a light signal that is recorded by a CCD camera in a sequencing instrument. The signal strength is proportional to the number of nucleotides incorporated. Pyrosequencing makes use of pyrophosphate (PPi) which is released upon nucleotide addition. PPi is converted to ATP by ATP sulfurylase in the presence of adenosine 5' phosphosulfate. Luciferase uses ATP to convert luciferin to oxyluciferin, and this reaction generates light that is detected and analyzed.

Another example of a DNA sequencing technique that can be used in the methods of the provided invention is Ion Torrent sequencing (U.S. patent application numbers 2009/0026082, 2009/0127589, 2010/0035252, 2010/0137143, 2010/0188073, 2010/0197507, 2010/0282617, 2010/0300559), 2010/0300895, 2010/0301398, and 2010/0304982), the content of each of which is incorporated by reference herein in its entirety. In Ion Torrent sequencing, DNA is sheared into fragments of approximately 300-800 base pairs, and the fragments are blunt ended.

Oligonucleotide adaptors are then ligated to the ends of the fragments. The adaptors serve as primers for amplification and sequencing of the fragments. The fragments can be attached to a surface and is attached at a resolution such that the fragments are individually resolvable. Using the methods of the present invention, the joined fragments are attached to the surface. Addition of one or more nucleotides releases a proton (H⁺), which signal detected and recorded in a sequencing instrument. The signal strength is proportional to the number of nucleotides incorporated.

FIG. 11 illustrates the preparation of beads for Ion Torrent sequencing using emulsion PCR methods of the invention. As with the linked template preparation methods described above, a sample nucleic acid fragment 701, such as cell-free DNA having a region of interest 724, is ligated 703 with adapters including linear PCR primers 727 at one end and universal PCR primers 728 at the other to form a template molecule 730. An emulsion is then created 713 comprising a single template molecule 730, multiplex gene-specific primers 723, and a plurality of linked primers joined together on a bead 729 in a droplet 726. The template is then amplified 715 in the droplet using known PCR methods to create a bead with numerous copies of the template molecule 730, which may now harbor PCR introduced errors 721. The emulsion is then broken and the bead-linked fragments 731 are loaded 717 into the flow cell sequencing well 732 for Ion Torrent sequencing. Most of the beads will be lost during flow cell loading with only a small fraction of the fragment containing beads 731 making it into a flow cell well 732.

FIG. 12 illustrates the error identification advantages of Ion Torrent sequencing using beads seeded from a single template molecule according to methods of the invention, where mixed bases in reads from a single well is indicative of a PCR error while consensus reads that may differ from other wells or from reference genomes may indicate a true variant in the sample nucleic acid.

The invention also encompasses methods of sequencing amplified nucleic acids generated by solid-phase amplification. Thus, the invention provides a method of nucleic acid sequencing comprising amplifying a pool of nucleic acid templates using solid-phase amplification and carrying out a nucleic acid sequencing reaction to determine the sequence of the whole or a part of at least one amplified nucleic acid strand produced in the solid-phase amplification reaction. The initiation point for the sequencing reaction may be provided by annealing of a sequencing primer to a product of a solid-phase amplification reaction. In this

connection, one or both of the adaptors added during formation of the template library may include a nucleotide sequence which permits annealing of a sequencing primer to amplified products derived by whole genome or solid-phase amplification of the template library.

The products of solid-phase amplification reactions wherein both forward and reverse amplification primers are covalently immobilized on the solid surface are so-called bridged structures formed by annealing of pairs of immobilized polynucleotide strands and immobilized complementary strands, both strands being attached to the solid support at the 5' end. Arrays comprised of such bridged structures provide inefficient templates for typical nucleic acid sequencing techniques, since hybridization of a conventional sequencing primer to one of the immobilized strands is not favored compared to annealing of this strand to its immobilized complementary strand under standard conditions for hybridization.

In order to provide more suitable templates for nucleic acid sequencing, it may be advantageous to remove or displace substantially all or at least a portion of one of the immobilized strands in the bridged structure in order to generate a template which is at least partially single-stranded. The portion of the template which is single-stranded will thus be available for hybridization to a sequencing primer. The process of removing all or a portion of one immobilized strand in a 'bridged' double-stranded nucleic acid structure may be referred to herein as linearization, and is described in further detail in U.S. Pub. 2009/0118128, the contents of which are incorporated herein by reference in their entirety.

Bridged template structures may be linearized by cleavage of one or both strands with a restriction endonuclease or by cleavage of one strand with a nicking endonuclease. Other methods of cleavage can be used as an alternative to restriction enzymes or nicking enzymes, including inter alia chemical cleavage (e.g. cleavage of a diol linkage with periodate), cleavage of abasic sites by cleavage with endonuclease (for example 'USER', as supplied by NEB, part number M55055), or by exposure to heat or alkali, cleavage of ribonucleotides incorporated into amplification products otherwise comprised of deoxyribonucleotides, photochemical cleavage or cleavage of a peptide linker

Following the cleavage step, regardless of the method used for cleavage, the product of the cleavage reaction may be subjected to denaturing conditions in order to remove the portion(s) of the cleaved strand(s) that are not attached to the solid support. Suitable denaturing conditions, for example sodium hydroxide solution, formamide solution or heat, will be apparent to the

skilled reader with reference to standard molecular biology protocols (Sambrook et al., supra; Ausubel et al. supra). Denaturation results in the production of a sequencing template which is partially or substantially single-stranded. A sequencing reaction may then be initiated by hybridization of a sequencing primer to the single-stranded portion of the template.

Thus, the invention encompasses methods wherein the nucleic acid sequencing reaction comprises hybridizing a sequencing primer to a single-stranded region of a linearized amplification product, sequentially incorporating one or more nucleotides into a polynucleotide strand complementary to the region of amplified template strand to be sequenced, identifying the base present in one or more of the incorporated nucleotide(s) and thereby determining the sequence of a region of the template strand.

Another example of a sequencing technology that can be used in the methods of the provided invention is Illumina sequencing. Illumina sequencing workflow is based on three steps: libraries are prepared from virtually any nucleic acid sample, amplified to produce clonal clusters and sequenced using massively parallel synthesis. Illumina sequencing is based on the amplification of DNA on a solid surface using fold-back PCR and anchored primers. Genomic DNA is fragmented, and adapters are added to the 5' and 3' ends of the fragments. DNA fragments that are attached to the surface of flow cell channels are extended and bridge amplified. Using the methods of the present invention, the joined fragments are attached to the flow cell channels and extended and bridge amplified. In some embodiments, the linker is removed prior to bridge amplification. In some embodiments, the linker remains attached to the fragments during amplification. The fragments become double stranded, and the double stranded molecules are denatured. Multiple cycles of the solid-phase amplification followed by denaturation can create several million clusters of approximately 1,000 copies of single-stranded DNA molecules of the same template in each channel of the flow cell. Primers, DNA polymerase and four fluorophore-labeled, reversibly terminating nucleotides are used to perform sequential sequencing. After nucleotide incorporation, a laser is used to excite the fluorophores, and an image is captured and the identity of the first base is recorded. The 3' terminators and fluorophores from each incorporated base are removed and the incorporation, detection and identification steps are repeated. Sequencing according to this technology is described in U.S. Pat. 7,960,120; U.S. Pat. 7,835,871; U.S. Pat. 7,232,656; U.S. Pat. 7,598,035; U.S. Pat. 6,911,345; U.S. Pat. 6,833,246; U.S. Pat. 6,828,100; U.S. Pat. 6,306,597; U.S. Pat. 6,210,891;

U.S. Pub. 2011/0009278; U.S. Pub. 2007/0114362; U.S. Pub. 2006/0292611; and U.S. Pub. 2006/0024681, each of which are incorporated by reference in their entirety.

Methods of the present invention can be incorporated into the Illumina sequencing platform (commercially available from Illumina, Inc, San Diego, CA). Using the present invention, libraries of linked complexes comprising two identical copies of a fragment or both strands of a duplex fragment are prepared and then attached to the solid support. The complexes are amplified to produce clonal clusters and then sequenced using massively parallel synthesis. In this method, each cluster is seeded with one fragment. With the present invention, two identical fragments or both strands of a duplex fragment are used to seed a cluster. During sequencing, if there is a lack of agreement at a particular base between the amplicons, the error is detected.

In a preferred embodiment, the joined fragments are attached to the flow cell channel walls. As shown in FIG. 2, complexes 109 and 119 are attached to a solid support 202, such as a flow cell channel wall. Complex 109 may comprise the sense and complex 119 may comprise the anti-sense. Each complex seeds a cluster. As shown in FIG. 2, complex 109 seeds cluster 1 (205) and complex 119 seeds cluster 2 (207).

FIG. 4A depicts an example of complex 401. Complex 401 comprises a linker 406 and identical copies of a nucleic acid template. However, one copy of the nucleic acid template comprises an error 410. Complex 401 attaches to solid support 402 via binding sites 405. In some examples, the binding sites 405 are complementary oligonucleotides (complementary to oligonucleotides on the complexes) that are covalently bound to the flow cell surface. As shown in FIG. 4B, complex 401 is extended and bridge amplified to create copies 418. This process is repeated, and as shown in FIG. 4C, a cluster 450 on the solid support 402 forms. From this process, the cluster is a mixture of oligonucleotides derived from each half of a complex. About half of the oligonucleotides contain the error and the other half does not.

FIG. 5A shows two complexes 502 and 503, where complex 502 contains an error 510. Primers, DNA polymerase and four fluorophore-labeled, reversibly terminating nucleotides are then introduced to perform sequential sequencing. After nucleotide incorporation, a laser is used to excite the fluorophores, and an image is captured and the identity of the first base is recorded. Since there is no error at the first base, both bases fluoresce the same. The 3' terminators and fluorophores from each incorporated base are removed and the incorporation, detection and

identification steps are repeated. The steps repeated until the base containing the error is reached. At this base, the bases do not fluoresce the same. The bases would fluoresce differently. As shown in FIG. 5B, the mixed fluorescence would indicate that the bases do not match. The mixed fluorescence would indicate an error, and the base would be reported as unknown, or N. See FIG. 5C.

FIG. 16 illustrates a droplet based method of the invention for creating linked duplex nucleic acids from the sense and antisense strands of a nucleic acid fragment. As shown, a double stranded cell-free DNA (cfDNA) having a rare variant on represented on both strands can be obtained. The double stranded template may then be added to an emulsion with one or more gene specific forward primers (e.g., the emulsion may contain multiplexed forward and reverse primers specific to more than one gene or part of a gene), one or more gene specific reverse primers, a universal linked primer. The emulsion may be subjected to emulsion PCR to create linked, duplex products. The emulsion can then be broken and unlinked template digested. The remaining, linked duplex products may then be sequenced. Because double stranded product enters droplet, with forward and reverse gene-specific primers, duplex sequence information may be obtained. The linked products of the emulsion PCR contain both template senses at least about 50% of time, which lowers average error rate. As shown in FIG. 16, a PCR error is introduced into the duplex product during the emulsion PCR but, because the PCR error is only present on one strand and the true variant is present on both, the two can be easily differentiated from each other during sequencing.

FIGS. 17 and 18 show exemplary universal linked primers and forward and reverse gene specific primers and methods for their use in PCR amplification to create linked duplex products. Preferably, the amplicon length is kept short to improve sensitivity. In the examples, the target region between primers is about 86bp. Additional gene specific primers are shown in FIG. 19.

FIGS. 20 and 21 illustrate sequencing methods of the invention using the products derived from FIGS. 17 and 18 respectively. The linked primers may contain two or more sites and may be made of PEG, Traptavidin bound to biotinylated DNA, DNA coated beads, DNA-coated nanoparticles, DNA-linked to gel based beads (e.g., acrylamide). Beads may be polystyrene, latex, magnetic, silica, ferromagnetic or similar materials. Attachment can be by conventional methods and preferably by a combination of amino and carboxyl groups.

Methods of the invention may include duplex identification strategies for droplet formed linked duplex molecules. As noted, droplet based methods of the invention may result in at least a 50% rate of linked duplex fragment formation (linked molecules that contain representations from each side of the DNA duplex) so, identification of those products becomes important in order to omit data from non-duplex products and reap the accuracy increasing benefits of the duplex products. Duplex identification methods may include, for example, a two-stage PCR approach using two sets of primers with different annealing temperatures where several initial cycles are performed at low temperature with gene-specific barcoding primers to amplify and identify each sense of the duplex, while adding a universal tail for subsequent cycles. The number of barcoding cycles is limited to prevent labeling each sense of the duplex with multiple barcodes. Subsequent cycles may then be performed at high temperature via universal primers because the barcoding primers are unable to bind under those conditions. Duplex products may then be identified by the presence of their sense specific barcodes during sequencing analysis.

FIGS. 29A-D illustrate duplex identification methods according to certain embodiments of the invention. In the illustrated example, the following may be added to the droplet: a linking primer; a universal forward primer and a universal reverse primer, each having a high T_m (T_m may be increased using LNA); a barcoded forward gene specific primer and a barcoded reverse gene specific primer, each having a lower T_m and at a lower concentration than the universal forward primer; and the duplex template. Emulsion PCR may then be run with a first cycle having a low annealing temperature to allow the barcoded primers to bind the template followed by a second low annealing temperature cycle to produce the products shown in FIG. 29B. A third low annealing temperature cycle allows the first cycle of universal primer binding. In this cycle, barcoded primers will still bind [A + B] to form more or the C and D products, and may also bind C and D products to form more E and F products.

After the third cycle, the products shown in FIG. 29C may be present in the emulsion, which may then be subjected to a 4th low annealing temperature cycle to allow a second cycle of universal primer binding. At the end of cycle 4, molecules with the full forward and reverse universal tails may be obtained as shown in FIG. 29C. The annealing temperature may be increased for subsequent cycles. There may be some I and J type products having different barcodes (e.g., they have the full universal tails on either the forward or reverse side). They can only amplify linearly at a higher annealing temp.

The subsequent PCR cycles (5+) may have an increased annealing temperature only allowing binding of universal primers to amplicons with a full universal tail as shown in FIG. 29D. The last few cycles may be at a low annealing temperature to allow the linking of amplified strands via a portion of the forward universal tail. Alternatively, a longer linked primer may be used with the full forward universal tail which allows linking at higher annealing temperatures but is harder to synthesize and may be less efficient in linking. Linking top or bottom sense occurs at random so 50% of linked molecules using this linked primer should have 1 of each (duplex info). Linked primers with more than 2 sites, for example 100 sites on a nanoparticle, on average contain duplex information nearly 100% of the time.

In certain embodiments, linked duplex molecules may be created without the use of emulsion PCR. In non-droplet embodiments, a single amplification cycle may be used to create a linked duplex molecule having both the sense and antisense strands of the original fragment. The linked duplex molecule may then be directly loaded in a flow cell for sequencing, thereby avoiding amplification induced sequence or length biases or (e.g., in whole genome sequencing) as well as avoiding amplification introduced errors and nucleic acid losses from poor loading efficiency. For example, where loading efficiency of a sequencer can be defined as: (number of output reads)/ (number of input molecules able to form reads), the loading efficiency for the Illumina MiSeq is <0.1%, and is similar for other Illumina instruments. This is largely due to fluidic losses, since over 600uL of sample is loaded into the sequencer, while only ~7uL is retained inside the flow cell for binding, resulting in large losses of starting material. The non-droplet, direct load methods described herein remedy these inefficiencies. Methods of the invention may include a simplified workflow that creates duplex molecule with one cycle of PCR. The duplex molecules can then be used to seed a single cluster and provide high accuracy sequencing reads. By loading the flow cell directly and then sequencing, DNA losses through loading are minimized.

Direct load, non-droplet methods of the invention have applications including whole genome sequencing where a small mass of DNA is present, but high accuracy is desired, such as tissue biopsy, needle aspirates, or small volume blood draws. Additional applications may include those where DNA is degraded or damaged, such as in formalin-fixed, paraffin-embedded (FFPE) samples.

FIGS. 22A, 22B, 23A, and 23B show non-droplet linked duplex formation methods according to certain embodiments of the invention. One (FIG. 22) or two (FIG. 23) linking adapters are ligated onto the double stranded genomic template and then extended using a strand displacing polymerase to create the linked duplex molecule. The linked duplex may then be directly loaded to a flow cell for sequencing. In two linking adapter applications such as illustrated in FIG. 23, linked fragments may be formed in two orientations (i.e., linked fragments having the linker on one end and linked fragments having the linker on the opposite end). As shown in FIGS. 22B and 22B, ligation may result in about 50% the desired, linked duplex product where other undesired products will not form clusters.

FIGS. 24A and 24B illustrate steps of a direct loading sequencing method using linked duplex molecules. In the exemplary method of FIGS. 24A and 24B, a flow cell is initialized with reagents. A small volume linked library is then denatured and the whole volume loaded onto the initialized flow cell. The flow cell ports are then sealed and the template such as created in the methods illustrated in FIGS. 22 and 23, is bound to the flow cell. The DNA on the flow cell is extended and then the flow cell is loaded on the flow cell sequencing instrument. Exemplary flow cell binding is illustrated in FIG. 25 including the steps of flow cell capture, extension, washing off of linked template, bridge amplification, and sequencing. Binding for the other sense strand of linked duplex template is analogous to that illustrated in FIG. 25.

FIG. 26 illustrates an exemplary off-line seeding protocol compared to a default protocol. In certain embodiments, steps of the off-line seeding protocol may include performing the following steps at the bench at room temperature: flush with LDR x 5, flush with PR2 x 5, flush with HT1, load TMP, and seal ports with PCR tape, where flush means filling the flow cell with the specified reagent, waiting about 10 seconds, and then emptying the flow cell. After sealing the ports with PCR tape, the flow cell is incubated in a bead bath at 75 degrees Celsius for 10 minutes, followed by incubation at 40 degrees Celsius for 10 minutes. Returning the flow cell to the bench at room temperature, the seal is removed, and the flow cell is flushed with PR2 at 40 degrees Celsius 5 times, flushed with AMS1 2 times, flushed with AMS1 with a two minute incubation at 40 degrees Celsius 3 times, filled with AMS1, and transferred to a MiSeq instrument (commercially available from Illumina, Inc, San Diego, CA) for sequencing. Additional steps in the preparation protocol may include taking the flow cell out from its plastic

housing, pre-cutting PCR tape for sealing ports, and protecting the flow cell from scratches from bead bath, with PCR tape or scotch tape on both sides.

For direct loading embodiments as well as other applications where the yield of flow cell loading and target capture yield are important, it may be beneficial to combine flow cell loading with targeted sequencing, to minimize loss. Such a combination additionally simplifies the workflow by eliminating an extra step. While methods exist for target capture on the flow cell, they suffer from at least two downsides. First, they are not able to sequence the region that is captured on the flow cell. For short fragments such as cell free DNA, this can amount to a large loss of signal. Secondly, they are unable to capture linked duplex molecules, as described in the invention, for sequencing. Accordingly, methods of the invention include flow cell based target capture of duplex molecules. According to methods of the invention, the flow cell contains one sense of oligonucleotides (oligos) having target regions, while the other sense are hair-pinned and not immediately available for binding. See FIG. 27. After one sense of linked molecules is captured on the flow cell, the other flow cell oligos are activated to capture the other sense of the linked fragments (e.g., using a uracil digest, enzyme digestion, or light). The template may then be extended and cluster generation may continue as normal. In certain embodiments the one set of oligos may be complementary to the sense or antisense strand of the duplex nucleic acid while the another set is complementary to a universal adapter that has been attached to both the sense and antisense strands and the universal adapter oligos may be hair-pinned to prevent binding in an initial exposure step.

FIGS. 28A-E illustrate steps of an exemplary method for flow cell based target capture of duplex molecules. FIG. 28A shows an exemplary target capture step where a linked molecule is loaded onto a flow cell, either directly or by conventional methods. FIG. 28B shows an exemplary step of binding the template to the flow cell where the linked molecule binds to a complementary capture region, and the other sense of flow cell oligos are released to bind both free ends of linked fragment. FIG. 28C shows an exemplary strand displacement step where strand displacing polymerase is used to extend both fragment to create a doubly-seeded cluster. The linked template may then be denatured and removed from the flow cell as shown in FIG. 28D. Bridge amplification may then occur as normal, but with two molecules seeding the cluster as shown in FIG. 28E.

Direct loading techniques of the invention may be used in whole genome sequencing applications without flow cell target capture steps with one or two linking adapters. In targeted sequencing applications, after ligation with one or two linked adapters, a tube-based target capture technique may be used that is optimized for yield (e.g., having poor off-target rejection but high yield). The linked duplex template may then be directly loaded into the flow cell as described above with or without the target capture steps described in FIGS. 28A-E. In certain embodiments the intermediate tube-based target capture step may be omitted.

The Illumina Genome Analyzer (detector, commercially available by Illumina) is based on parallel, fluorescence-based readout of millions of immobilized sequences that are iteratively sequenced using reversible terminator chemistry. In one example, up to eight DNA libraries are hybridized to an eight-lane flow cell. In each of the lanes, single-stranded library molecules hybridize to complementary oligonucleotides that are covalently bound to the flow cell surface. The reverse strand of each library molecule is synthesized and the now covalently bound molecule is then further amplified in a process called bridge amplification. This generates clusters each containing more than 1,000 copies of the starting molecule. One strand is then selectively removed, free ends are subsequently blocked and a sequencing primer is annealed onto the adapter sequences of the cluster molecules.

Although the fluorescent imaging system is not sensitive enough to detect the signal from a single template molecule, the detector is sensitive to detect the signal from each cluster. In this example of the invention, the signals from numerous clusters are analyzed. Each cluster is expected to fluoresce at a value, for example, approximate to one of the four bases. If the cluster does not fluoresce at a value approximate to one of the four bases, then it is determined that an error exists at that locus.

After sequencing, images are analyzed and intensities extracted for each cluster. The Illumina base caller, Bustard, has to handle two effects of the four intensity values extracted for each cycle and cluster: first, a strong correlation of the A and C intensities as well as of the G and T intensities due to similar emission spectra of the fluorophores and limited separation by the filters used; and second, dependence of the signal for a specific cycle on the signal of the cycles before and after, known as phasing and pre-phasing, respectively. Phasing and pre-phasing are caused by incomplete removal of the 3' terminators and fluorophores, sequences in the cluster missing an incorporation cycle, as well as by the incorporation of nucleotides without

effective 3' terminators. Phasing and pre-phasing cause the extracted intensities for a specific cycle to consist of the signal of the current cycle as well as noise from the preceding and following cycles.

Another example of a sequencing technology that can be used in the methods of the provided invention includes the single molecule, real-time (SMRT) technology of Pacific Biosciences. In SMRT, each of the four DNA bases is attached to one of four different fluorescent dyes. These dyes are phospholinked. A single DNA polymerase is immobilized with a single molecule of template single stranded DNA at the bottom of a zero-mode waveguide (ZMW). A ZMW is a confinement structure which enables observation of incorporation of a single nucleotide by DNA polymerase against the background of fluorescent nucleotides that rapidly diffuse in and out of the ZMW (in microseconds). It takes several milliseconds to incorporate a nucleotide into a growing strand. During this time, the fluorescent label is excited and produces a fluorescent signal, and the fluorescent tag is cleaved off. Detection of the corresponding fluorescence of the dye indicates which base was incorporated. The process is repeated. Using methods of the present invention, the process is repeated in tandem, with two fragments being analyzed.

Another example of a sequencing technique that can be used in the methods of the provided invention is nanopore sequencing (Soni G V and Meller A. (2007) Clin Chem 53: 1996-2001). A nanopore is a small hole, of the order of 1 nanometer in diameter. Immersion of a nanopore in a conducting fluid and application of a potential across it results in a slight electrical current due to conduction of ions through the nanopore. The amount of current which flows is sensitive to the size of the nanopore. As a DNA molecule passes through a nanopore, each nucleotide on the DNA molecule obstructs the nanopore to a different degree. Thus, the change in the current passing through the nanopore as the DNA molecule passes through the nanopore represents a reading of the DNA sequence. Using methods of the present invention, two fragments are analyzed simultaneously or sequentially, reducing the chance of an error.

The present invention can be used with nanopore technology, such as single molecule nanopore-based sequencing by synthesis (Nano-SBS). This strategy can distinguish four bases by detecting 4 different sized tags released from 5'-phosphate-modified nucleotides. As each nucleotide is incorporated into the growing DNA strand during the polymerase reaction, its tag is released and enters a nanopore in release order. This produces a unique ionic current blockade

signature due to the tag's distinct chemical structure, thereby determining DNA sequence electronically at single molecule level with single base resolution. Using the methods of the invention, two identical fragments or both strands of a duplex fragment can be analyzed simultaneously or sequentially. See Kumar, et al. Scientific Reports, Article number 684, doi:10.1038/srep00684.

Functions described above such as sequence read analysis or assembly can be implemented using systems of the invention that include software, hardware, firmware, hardwiring, or combinations of any of these.

One sequencing method which can be used in accordance with the invention relies on the use of modified nucleotides having removable 3' blocks, for example as described in W004018497, US 2007/0166705A1 and U.S. Pat. No. 7,057,026, the contents of which are incorporated herein by reference in their entirety. Once the modified nucleotide has been incorporated into the growing polynucleotide chain complementary to the region of the template being sequenced there is no free 3'-OH group available to direct further sequence extension and therefore the polymerase cannot add further nucleotides. Once the nature of the base incorporated into the growing chain has been determined, the 3' block may be removed to allow addition of the next successive nucleotide. By ordering the products derived using these modified nucleotides, it is possible to deduce the DNA sequence of the DNA template. Such reactions can be done in a single experiment if each of the modified nucleotides has a different label attached thereto, known to correspond to the particular base, to facilitate discrimination between the bases added during each incorporation step. Alternatively, a separate reaction may be carried out containing each of the modified nucleotides separately.

FIGS. 32 and 33 illustrate alternative sequencing methods using systems and methods of the invention. As shown in FIG. 32, after seeding clusters with multiple template copies and amplifying, errors can be differentiated from true variants through a drop in sequencing quality in a single read at the position where the bases are not the same. Because all amplified strands in the cluster are all read at the same time, in the same direction, a drop in signal quality is the only way to determine a mixed base call within the cluster. In embodiments wherein a cluster is seeded with both a sense and antisense strand or templates having different sequencing primer sites, true variants and errors may be identified by comparing results from two different sequencing reads (e.g., reads from each sense or reads using the two different sequencing

primers). FIG. 33 illustrates methods of the invention using two separate sequencing reads to compare base calls from a sense and antisense read. Sequencing or other introduced errors should only be seen on one of the reads while true variants should be observed on both reads.

Linked target capture methods may include solution-based capture of genomic regions of interest for targeted DNA sequencing. FIGS. 34 and 35 illustrate exemplary methods of solution-based target capture. Universal probes and optional barcodes (which may be sense specific) are ligated to extracted DNA. The ligated DNA product is then denatured and bound with linked target capture probes comprising a universal priming site and universal probe linked to a target specific probe. Target capture is performed at a temperature where the universal probes cannot bind alone unless local concentration is high due to the binding of the target probe. Strand displacing polymerase (e.g., BST, phi29, or SD) is then used to extend the target-bound linked probes. The target probe is blocked from extension as indicated by the black diamond in FIGS. 34 and 35 so that extension only occurs along the bound universal probe, copying the bound target nucleic acid strand that remains linked to the target probe. A number of linked-PCR extension cycles can then be used to amplify the target sequences. PCR can then be performed using universal primers corresponding to the universal priming sites from the linked target capture probes to amplify one or both strands of the target nucleic acid. This PCR step can be performed in the same reaction without the need for a cleanup step. The amplified target sequence can then be sequenced as described above. No gap is required between the linked capture probes when used in opposite directions although a gap is possible. The capture probes may be produced using universal 5'-linkers by joining the universal linkers to a pre-made capture probe. The capture probes can be joined by streptavidin/biotin or other means as described above and the universal linker may be extended using the capture probe as a template.

Methods of the invention include droplet based target capture, optionally using universal linked primers, to capture duplex molecules. The droplet based methods depicted in FIG. 36 are similar to those illustrated in FIG. 16 but use linked target capture probes as described above and depicted in FIGS. 34-35. Universal probes and optional barcodes (which may be sense specific) are ligated to extracted DNA (e.g., cell-free DNA). An emulsion is created as described above using a duplex template molecule and target capture probes comprising a universal priming site and universal probe linked to a target specific probe. As above, target capture is performed at a temperature where the universal probes cannot bind alone unless local concentration is high due

to the binding of the target probe and the capture probes are blocked from extending themselves but include a universal priming site such that universal primers and linked universal primers included in the emulsion can be used to amplify the target nucleic acid to produce a linked duplex molecule comprising both sense and antisense strands of the target nucleic acid. Universal linkers may be omitted to perform target capture alone. The emulsion can then be broken and un-linked template can be digested enzymatically leaving only linked duplex molecules can then seed clusters or otherwise be sequenced as described above.

FIGS. 37A and B provide additional details of droplet-based target capture methods of the invention. Step 0 in FIG. 37A shows a duplex template molecule with universal probes and optional barcodes ligated to it is loaded into a droplet with linked and universal primers and target capture probes. The template DNA is denatured in the droplet and the target capture probes then bind the denatured template strands at a temperature where the universal probe will not bind alone unless the target probe is also bound. The universal primer then only binds to captured targets. Extension with strand displacing polymerase then occurs only on the captured targets. Moving to FIG. 37B, extension cycles are then run (e.g., 4-6 cycles) until the linked target capture probes and primers are exhausted. The resulting extension products are then amplified using the universal linked primers to produce linked duplex molecules with strand specific barcodes. As with the solution-based methods, no gap is required between the linked capture probes when in opposite directions. The linked capture probes can be used in one or both directions if omitting the universal linkers to perform target capture alone. Conventional polymerases can be mixed with strand displacing polymerases within the droplet to carry out the various extension and amplification steps of the method.

Certain methods of the invention relate to target capture of linked molecules. Linked copies of molecules such as those created using the methods described above may be targeted and captured and converted to linked molecules for sequencing. FIGS. 38-42 illustrate exemplary methods of nanoparticle target capture of linked molecules. FIG. 38 shows a nanoparticle having universal primers and a strand comprising a target region complementary to a capture region of the linked molecule to be captured. FIG. 39 illustrates binding of the capture region to the target region. This step occurs at a temperature where the target/capture regions will bind but the universal primers will not bind. Unbound templates may be washed away at this step. The temperature of the reaction may then be lowered to allow for universal primer

binding. FIG. 40 shows binding of the universal primers to universal primer sites on the linked molecule. FIG. 41 shows universal primer extension by strand displacing polymerase to produce nanoparticle linked copies of the target molecule comprising both strands of the original linked molecule. FIG. 42 shows a doubly seeded nanoparticle that may be used to seed a cluster on a flow cell sequencer as described elsewhere in the application.

Embodiments of the invention may incorporate modified nucleotides. The modified nucleotides may be labeled (e.g., fluorescent label) for detection. Each nucleotide type may thus carry a different fluorescent label, for example, as described in U.S. Pub. 2010/0009353, the contents of which are incorporated herein by reference in their entirety. The detectable label need not, however, be a fluorescent label. Any label can be used which allows the detection of an incorporated nucleotide. One method for detecting fluorescently labeled nucleotides comprises using laser light of a wavelength specific for the labeled nucleotides, or the use of other suitable sources of illumination. The fluorescence from the label on the nucleotide may be detected by a CCD camera or other suitable detection means. Suitable instrumentation for recording images of clustered arrays is described in W007123744 and U.S. Pub. 2010/0111768, the contents of which are incorporated herein by reference in their entirety.

Example 1: Sequencing Error Reduction in KRAS Amplicon Using Double Seeded Clusters

Flow cell clusters were seeded with single template molecules. The single template copies were from a library of linked templates where only one of the linked template molecules was bound to the flow cell as shown in FIG. 31. The first 3000 singly-seeded clusters that aligned to the KRAS amplicon were then analyzed for sequencing errors with an applied quality threshold of greater than 35. The singly-seeded clusters resulted in a mean error of 0.13% with mean depth of about 3000 as shown in FIG. 30. Because the singly-seeded flow cell used a linked template library, the results may represent a lower error rate than would be experienced using a standard single-seeding method with unlinked template molecules.

Flow cell clusters were then doubly seeded using linked template molecules where both of the linked molecules were bound to the flow cell to seed the cluster. The first 3000 doubly-seeded clusters that aligned to the chr12 amplicon were then analyzed for sequencing errors with the same applied quality threshold of greater than 35 and a fluorescent chastity filter of 0.8 or greater. The doubly-seeded clusters provided a 7-fold reduction in sequencing errors with less

than 3% loss of analyzed bases over the singly-seeded clusters. The mean error rate for the doubly-seeded clusters was .02% with a mean depth of about 2920 as shown in FIG. 43.

Incorporation by Reference

References and citations to other documents, such as patents, patent applications, patent publications, journals, books, papers, web contents, have been made throughout this disclosure. All such documents are hereby incorporated herein by reference in their entirety for all purposes.

Equivalents

The invention may be embodied in other specific forms without departing from the spirit or essential characteristics thereof. The foregoing embodiments are therefore to be considered in all respects illustrative rather than limiting on the invention described herein.

What is claimed is:

1. A method of sequencing a nucleic acid, the method comprising:

ligating adapters to a copy of a sense strand and an antisense strand of a duplex nucleic acid fragment wherein at least one of the adapters is a linking adapter to create ligation products;
extending the ligation products with a strand displacing polymerase wherein the extended ligation products comprise a complex comprising joined copies of the sense strand of the duplex nucleic acid fragment and the antisense strand of the duplex nucleic acid fragment;
loading the extended ligation products on a sequencing flow cell; and
sequencing the extended ligation products.

2. The method of claim 1, wherein the linker is selected from the group consisting of a polyethylene glycol derivative, an oligosaccharide, a lipid, a hydrocarbon, a polymer, an inverted base, and a protein.

3. The method of claim 1, wherein the linking adapter comprises streptavidin and biotinylated DNA.

4. The method of claim 3, wherein the linking adapter comprises a streptavidin coated bead.

5. The method of claim 1, wherein the complex forms a seed for a single cluster.

6. The method of claim 1, wherein sequencing the extended ligation products comprises a first sequencing read of the sense strand copies and a second sequencing read of the antisense strand copies, the method further comprising identifying a consensus base call by comparing the first and second sequencing reads.

7. A method of sequencing a nucleic acid, the method comprising:

joining at least two copies of a nucleic acid fragment with a linker to form a complex, wherein the linker comprises a molecule that is not selected from the group consisting of guanine, cytosine, adenine, uracil or thymine;
annealing the complex to a solid support;

amplifying the complex; and
sequencing the amplification products.

8. The method of claim 7, wherein the linker comprises streptavidin and the at least two copies of the nucleic acid fragment comprise biotinylated DNA.

9. The method of claim 8, wherein the linker is a streptavidin coated bead.

10. The method of claim 7, wherein the at least two copies of the nucleic acid fragment are joined through a click chemistry reaction.

11. A method for targeted capture of duplex nucleic acids, the method comprising:

providing a flow cell comprising a plurality of oligonucleotides complementary to a first strand of a duplex nucleic acid and a plurality of oligonucleotides complementary to a universal adapter;

exposing linked first and second strands of the duplex nucleic acid to the flow cell wherein the linked first and second strands comprise a sense and an antisense strand of the duplex nucleic acid and each of the linked strands comprises the universal adapter;

capturing a copy of the first strand of the duplex nucleic acid on the flow cell;

capturing a copy of the second strand of the duplex nucleic acid linked to the captured copy of the first strand of the duplex nucleic acid; and

creating a cluster seeded with the copy of the first strand and the copy of the second strand of the duplex nucleic acid by extending the captured linked fragments with a strand displacing polymerase.

12. The method of claim 11 wherein the plurality of oligonucleotides complementary to the universal adapter are hair-pinned to prevent binding, the method further comprising:

releasing the hair-pinned plurality of oligonucleotides from a hair-pinned state after the copy of the first strand of the duplex nucleic acid is captured on the flow cell and before the copy of the second strand of the duplex nucleic acid is captured.

13. The method of claim 11 wherein the linked first and second strands of the duplex nucleic acid are linked by a linker molecule, the method further comprising:

denaturing the linked first and second strands of the duplex nucleic acid after creating the cluster.

14. The method of claim 13, wherein the linker molecule is selected from the group consisting of a polyethylene glycol derivative, an oligosaccharide, a lipid, a hydrocarbon, a polymer, an inverted base, and a protein.

15. The method of claim 13, wherein the linker molecule comprises streptavidin and biotinylated DNA.

16. The method of claim 12, wherein the hair-pinned plurality of oligonucleotides is released from the hair-pinned state by uracil digest, enzyme digestion, or light.

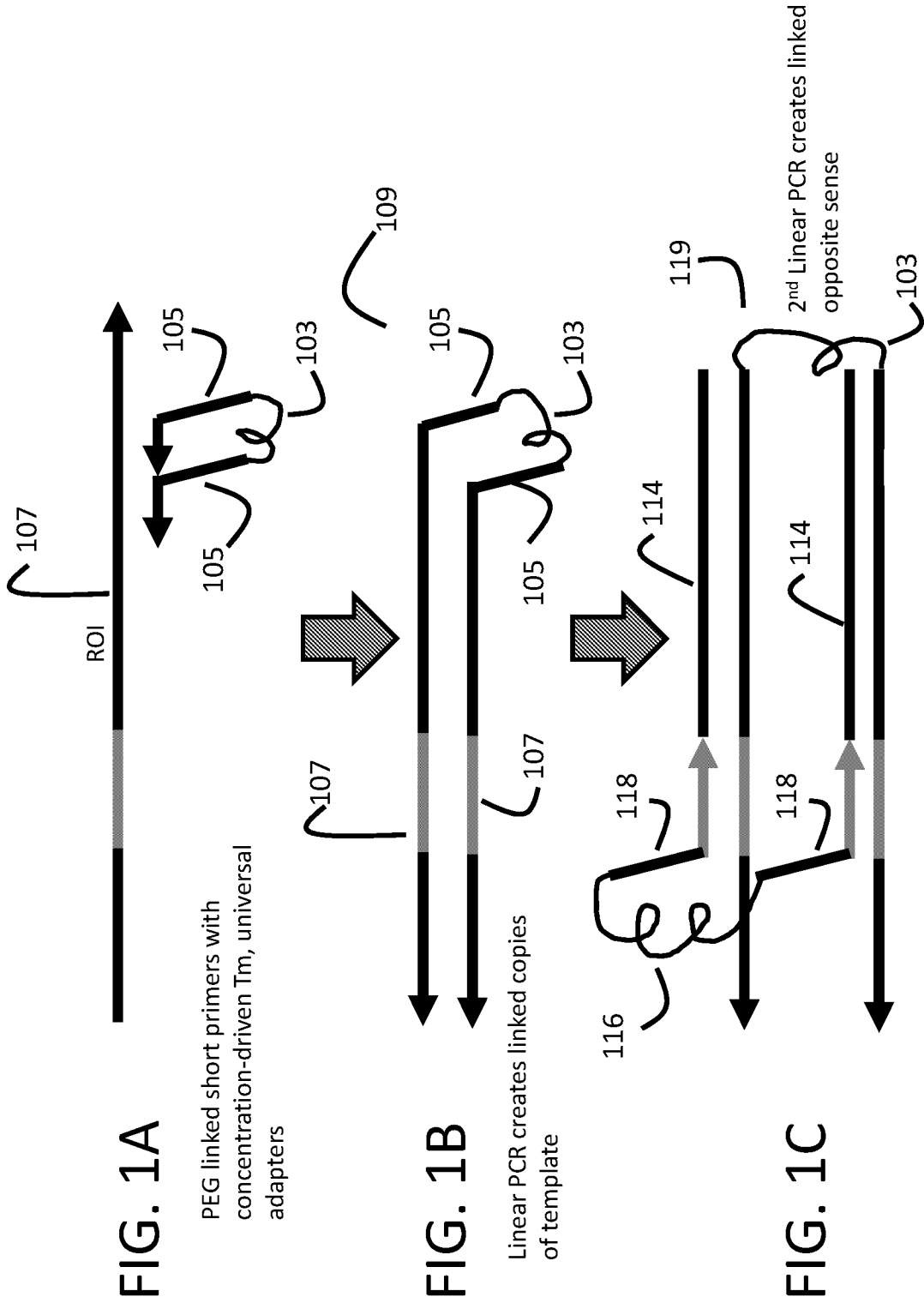

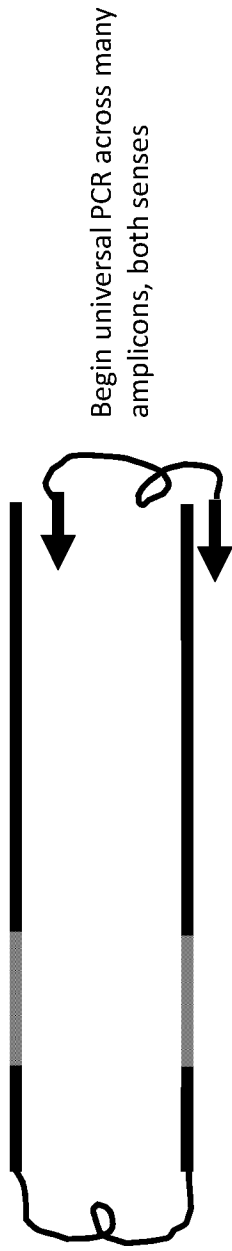

FIG. 1D

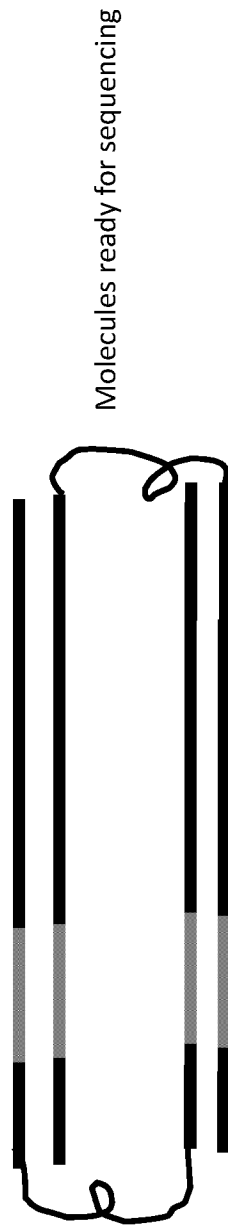

FIG. 1E

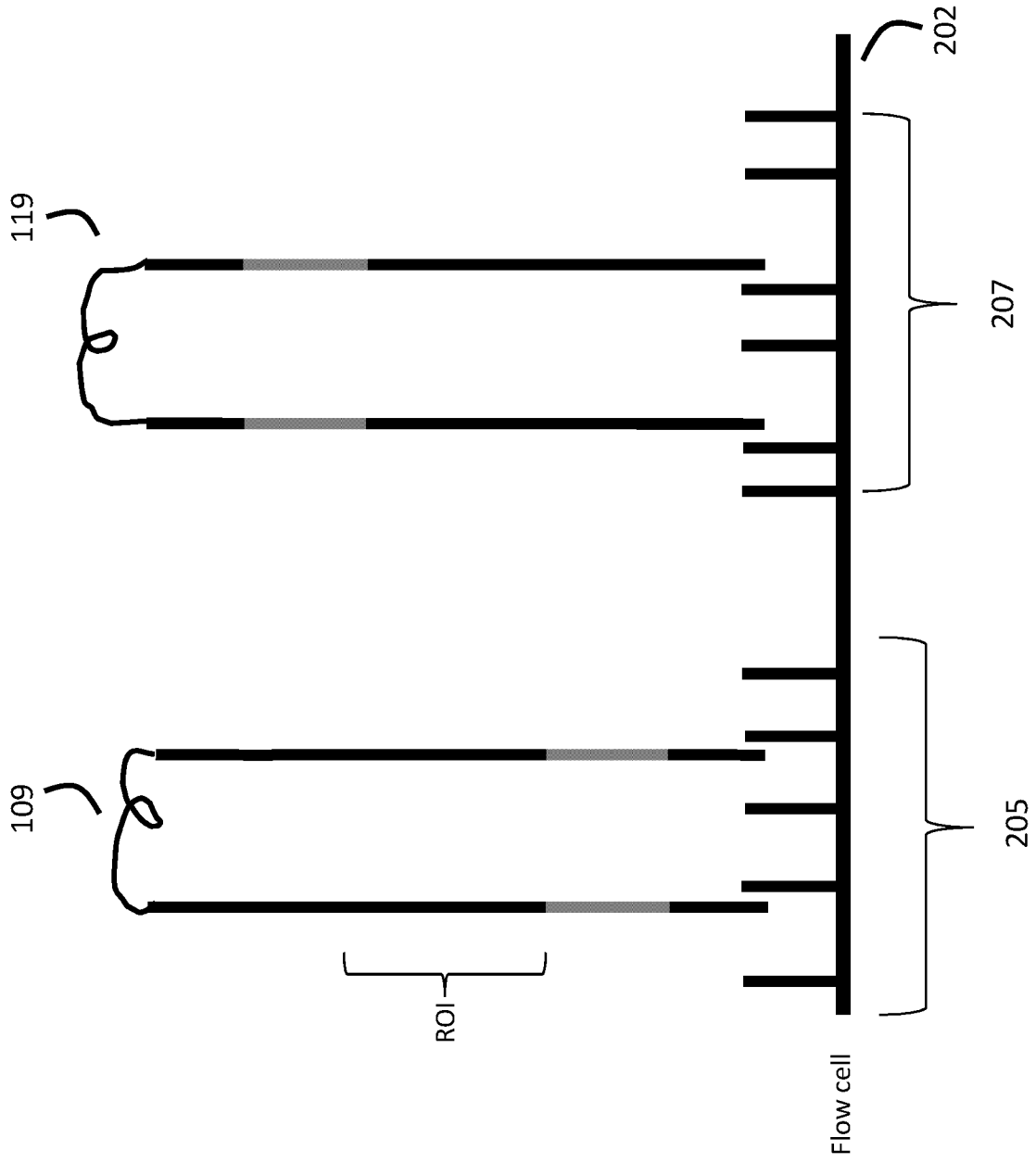
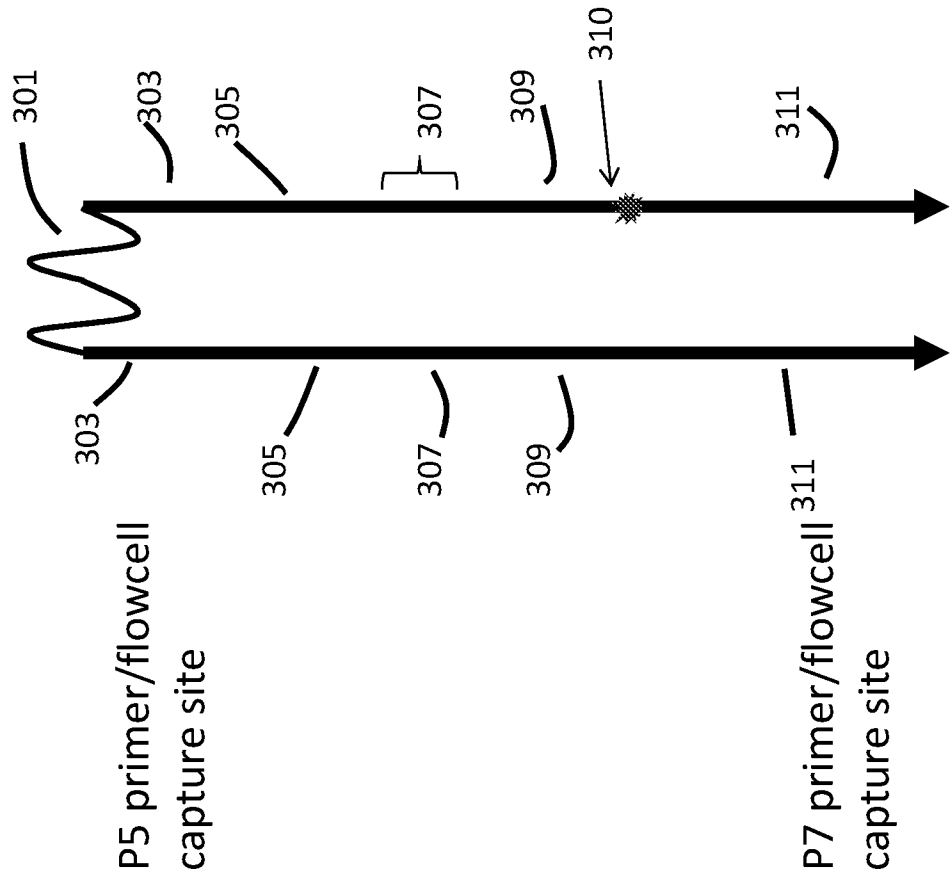

FIG. 2

FIG. 3



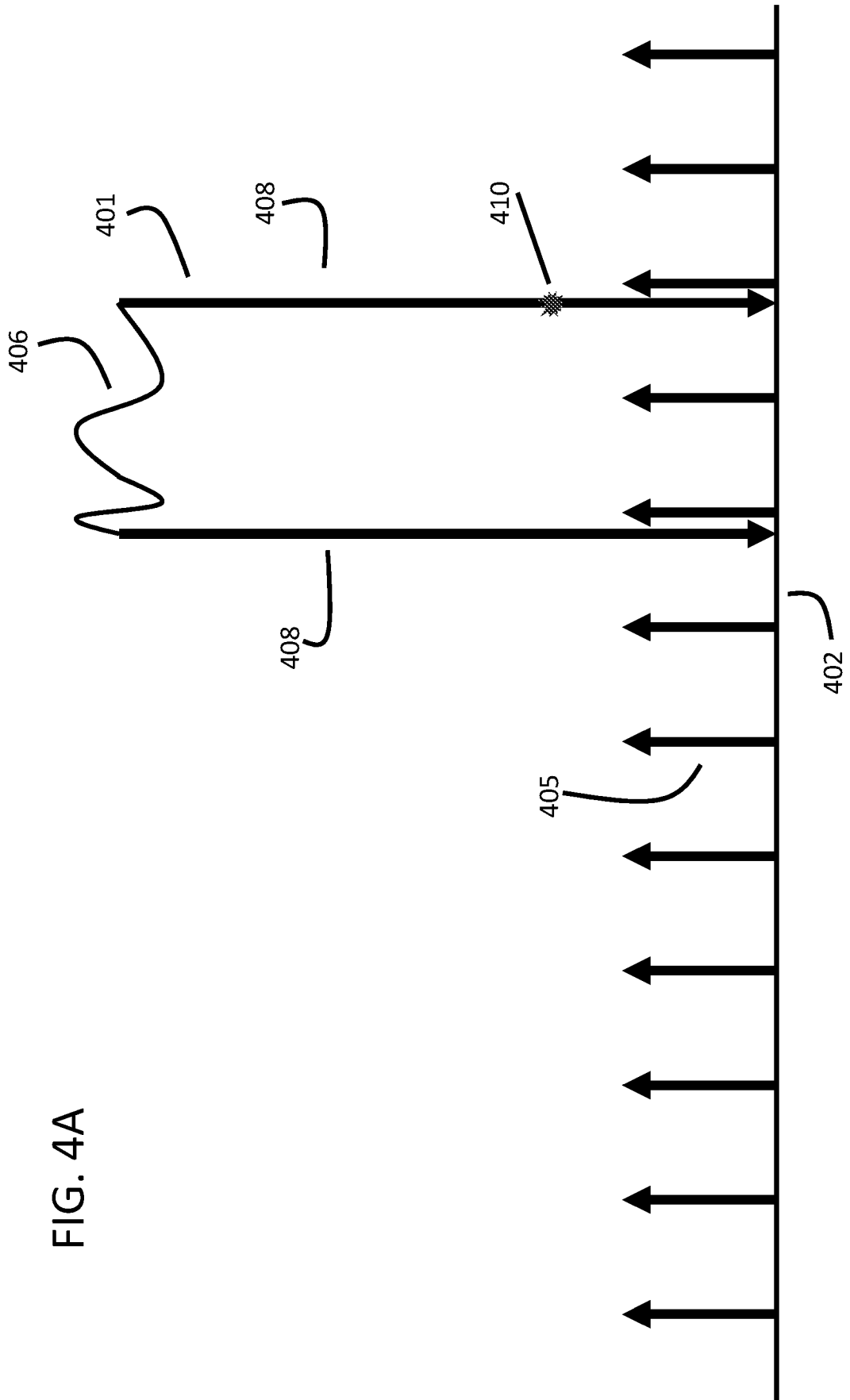
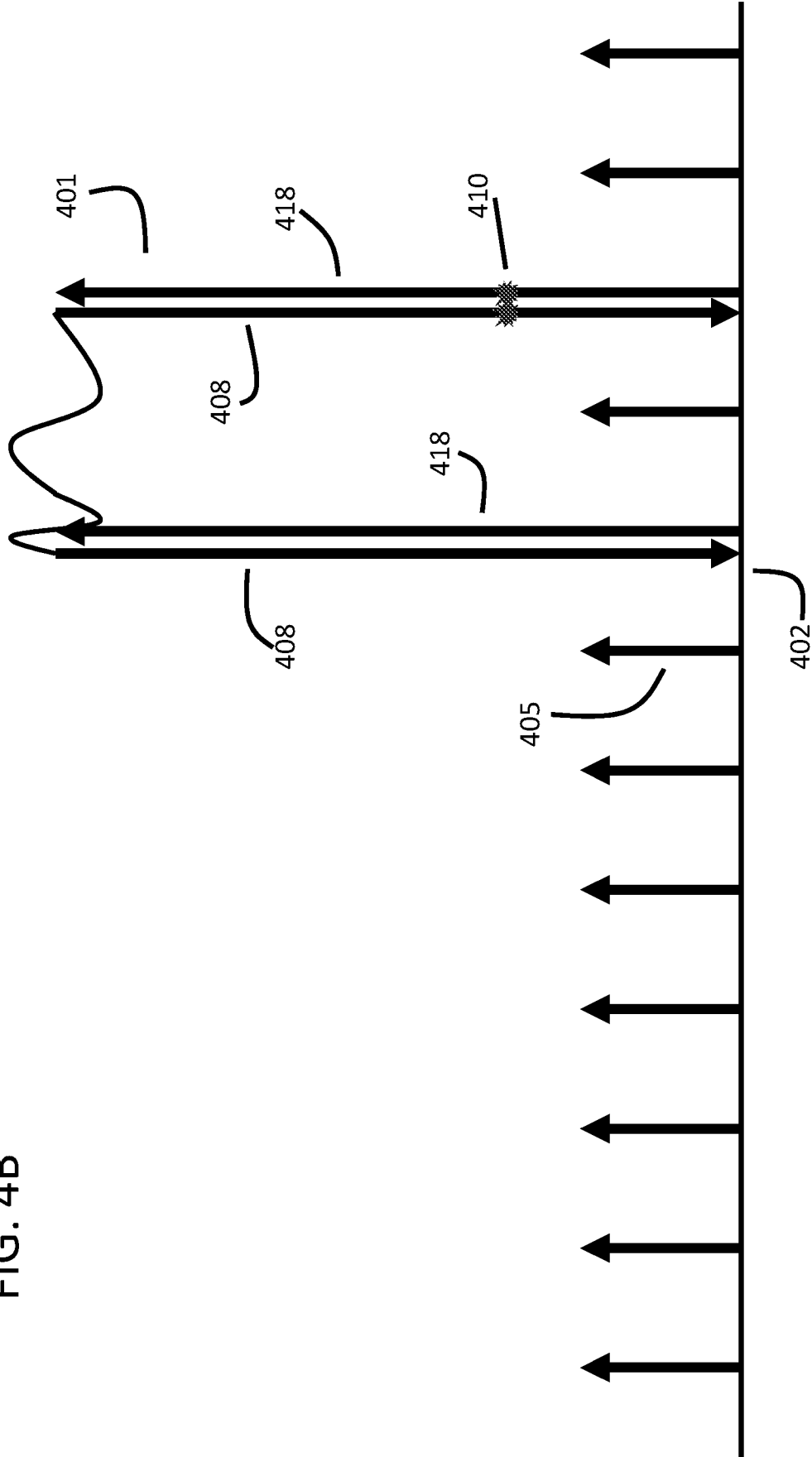

FIG. 4A

FIG. 4B



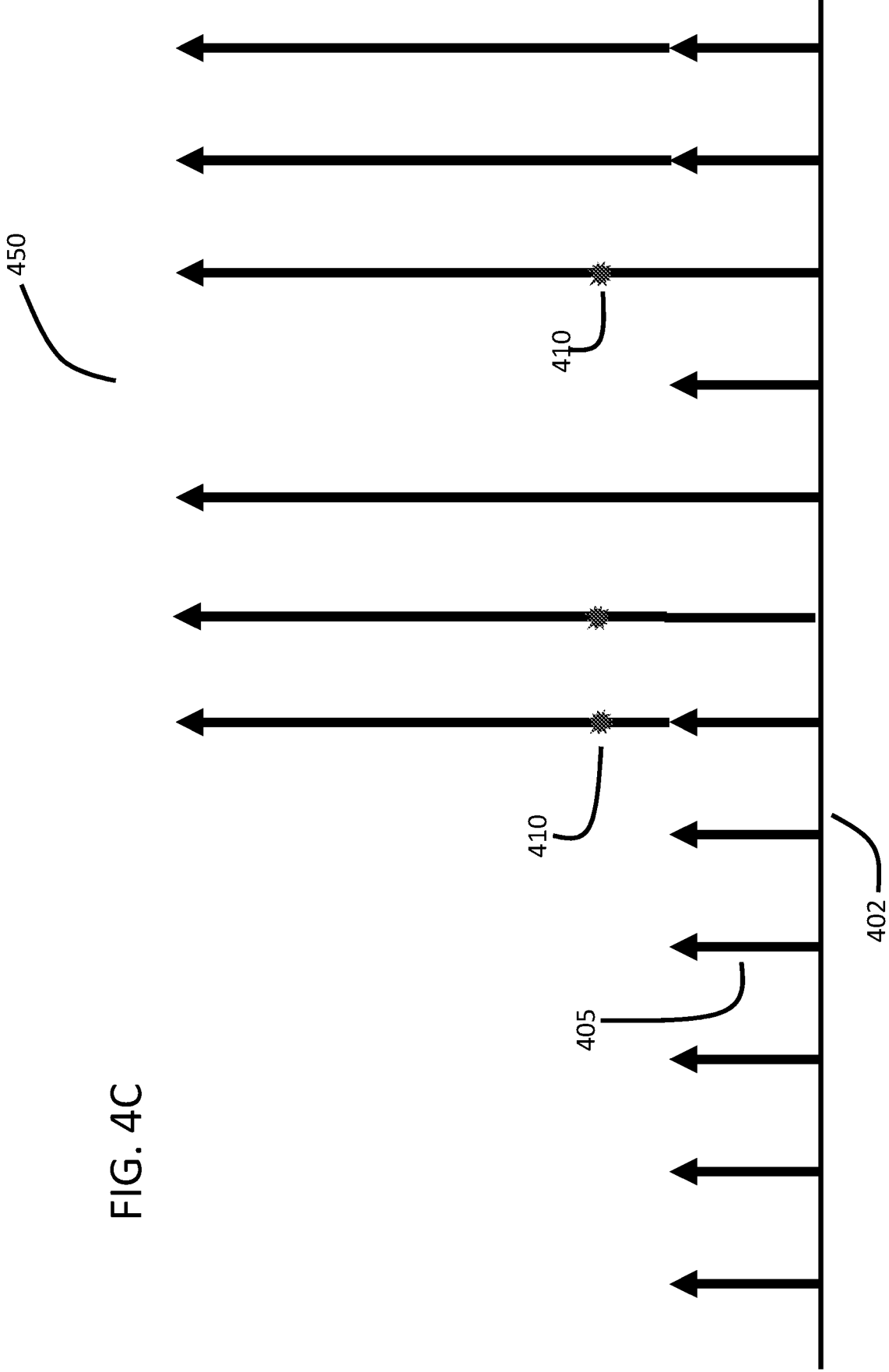

FIG. 4C

FIG. 5A

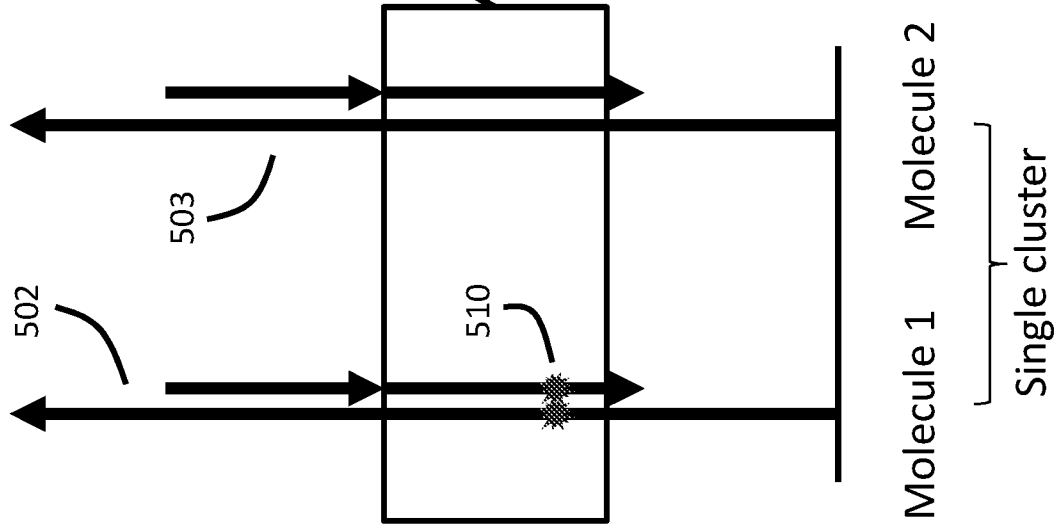

FIG. 5B

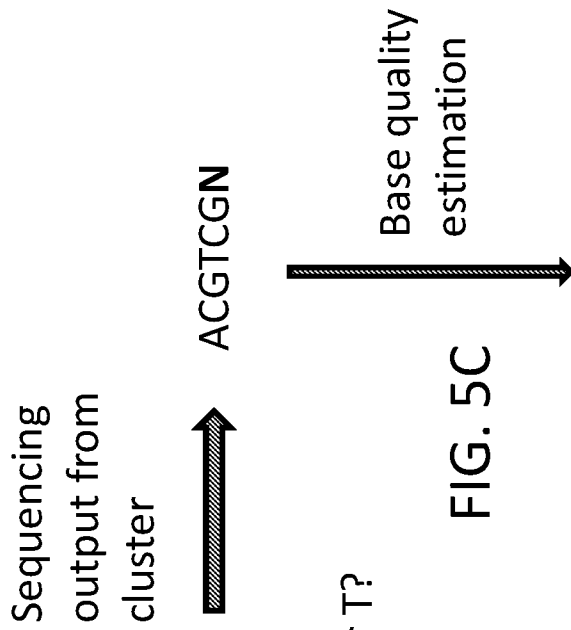
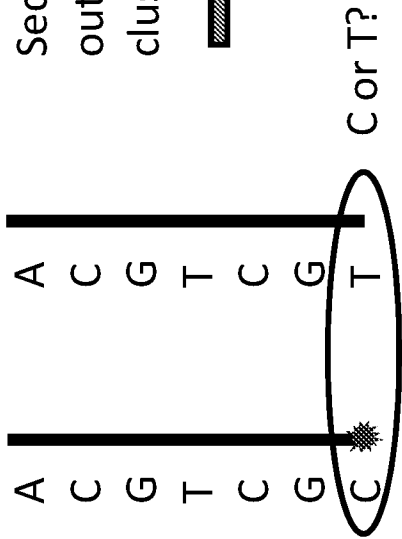

FIG. 5C

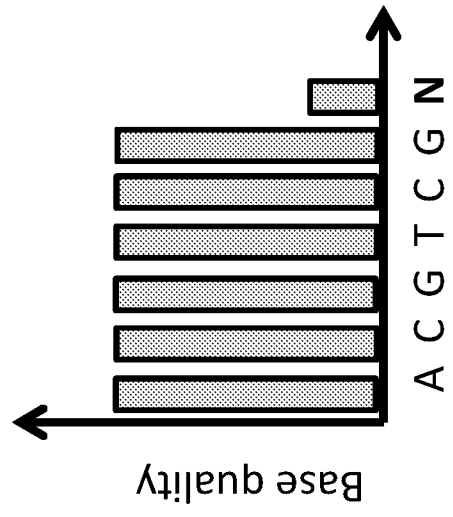
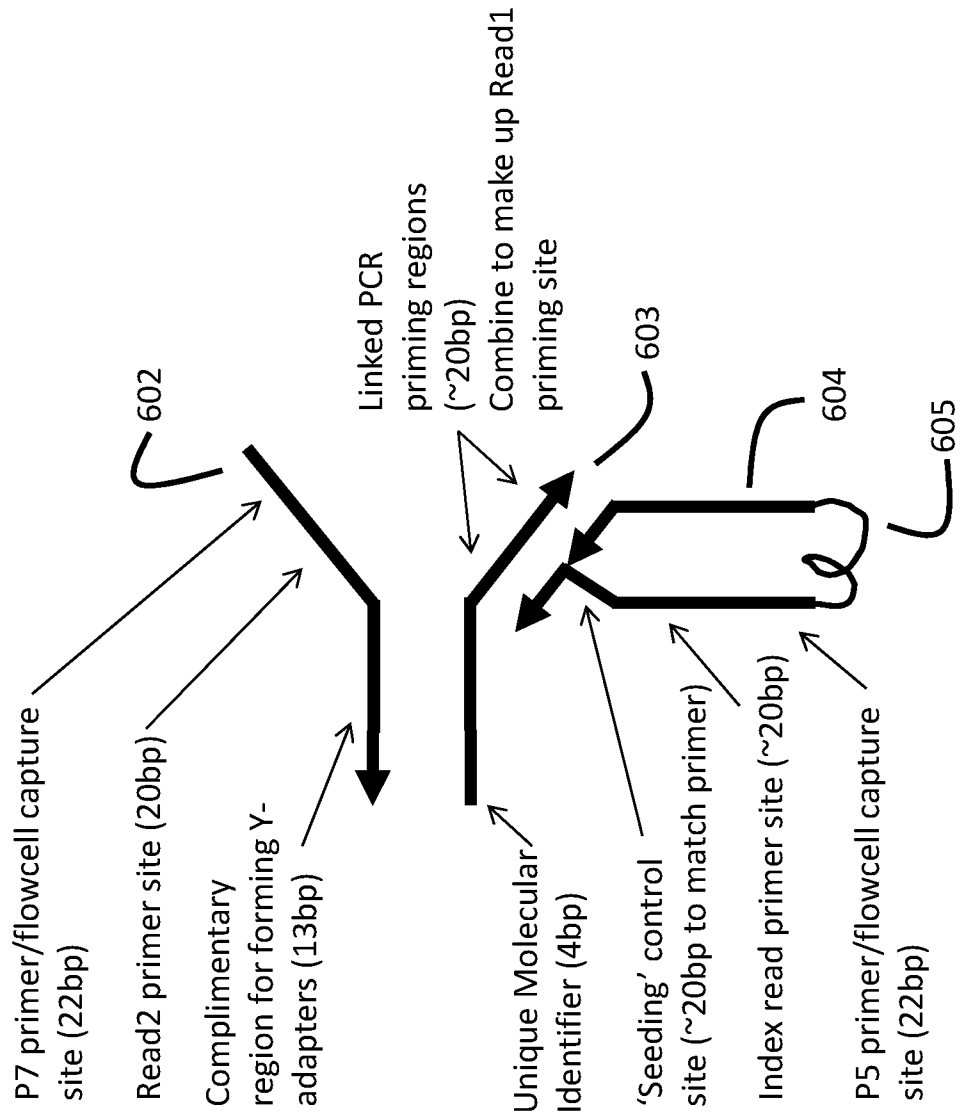

FIG. 6



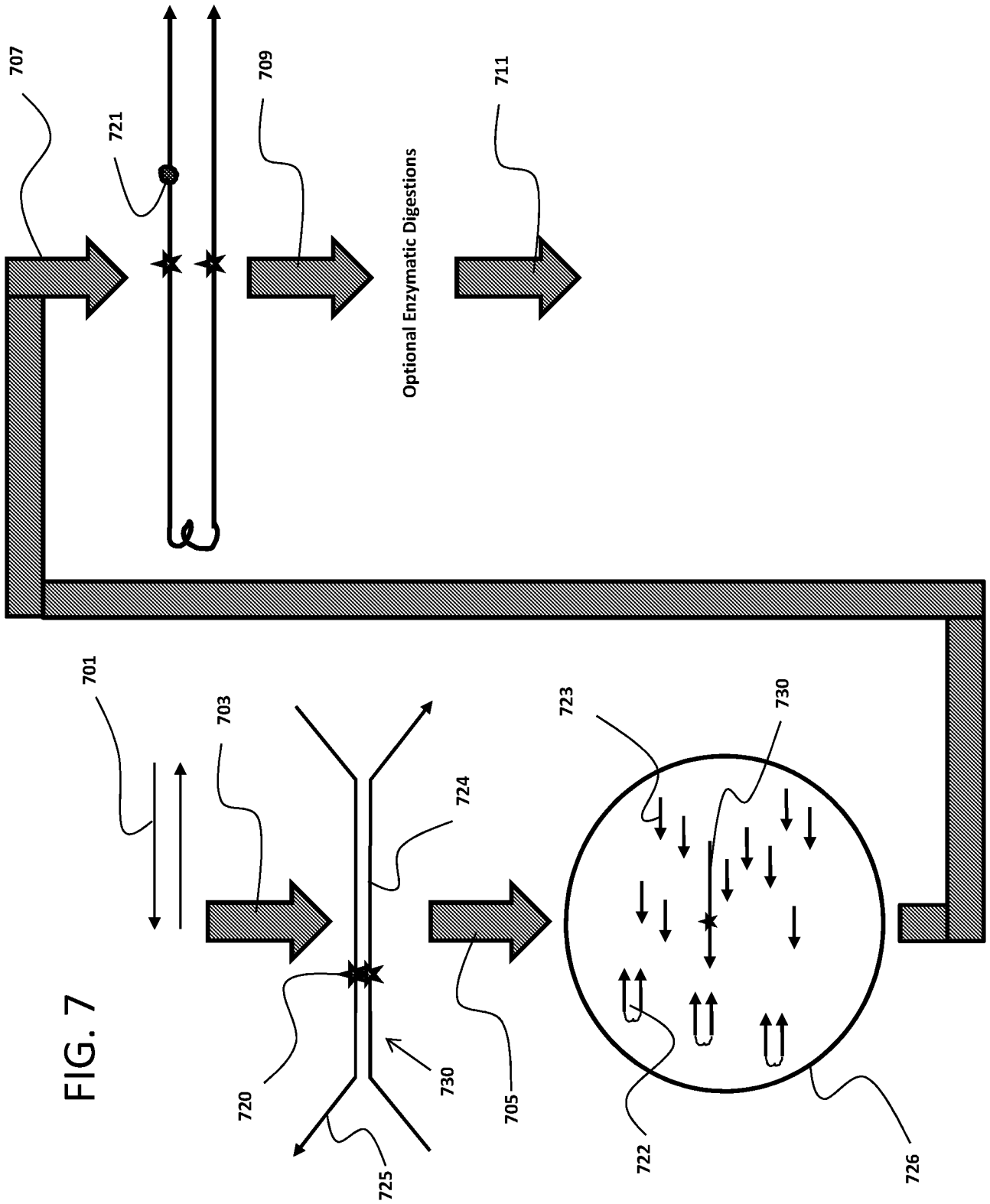

FIG. 7

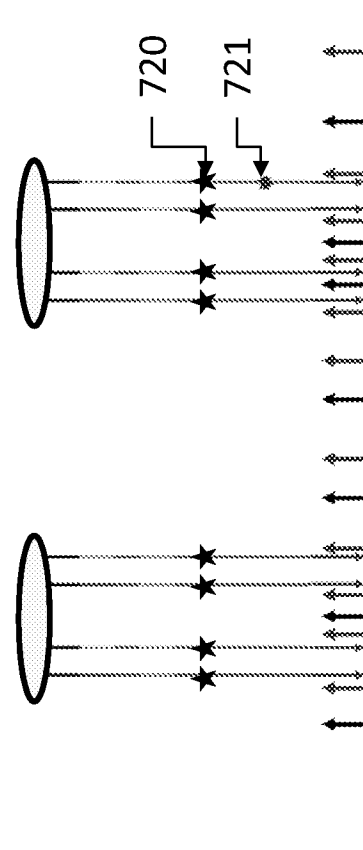
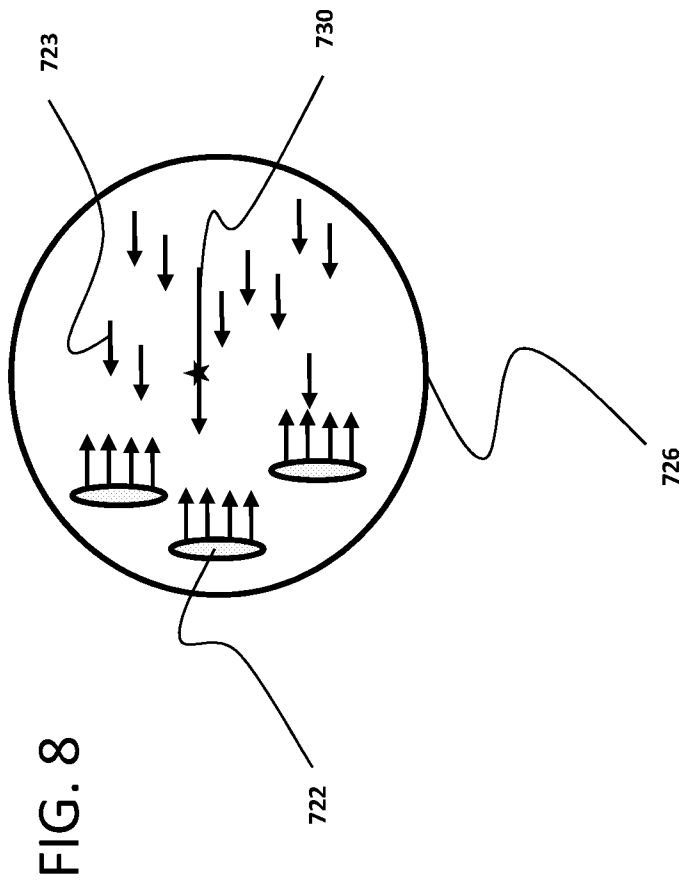

FIG. 9

FIG. 9

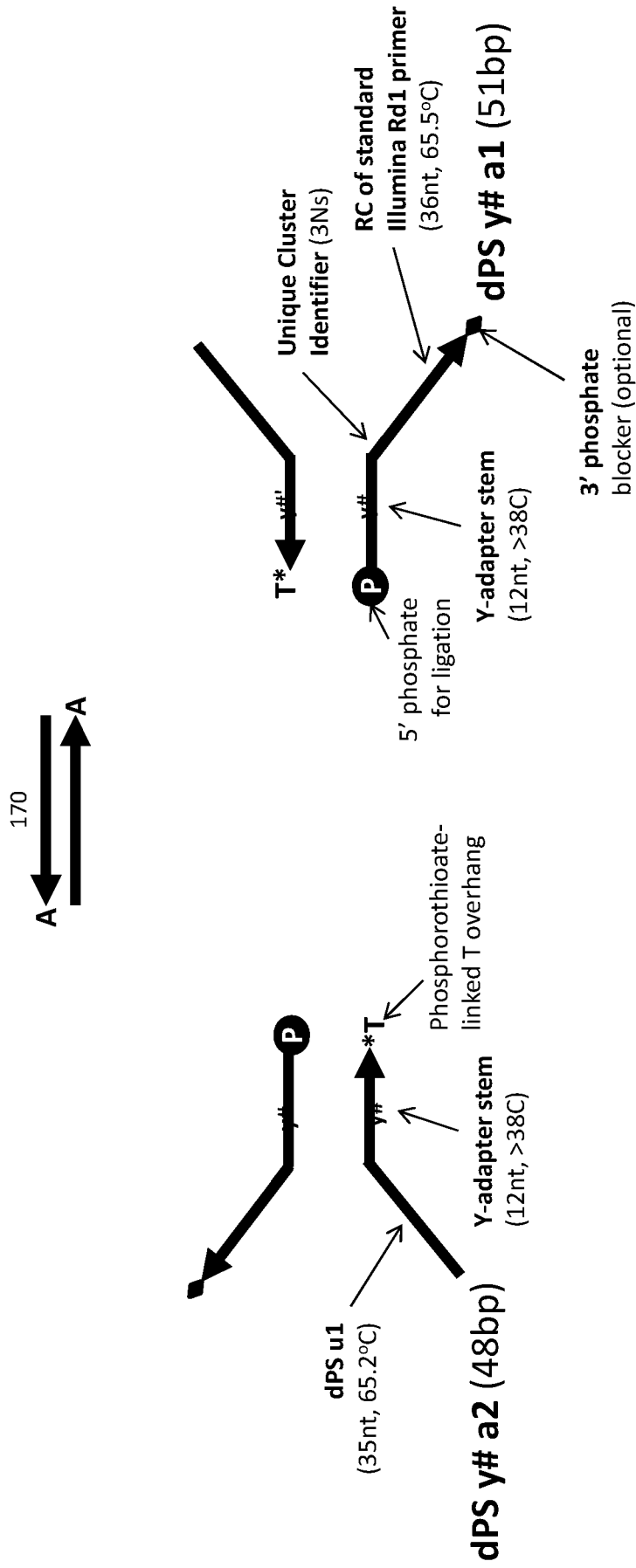
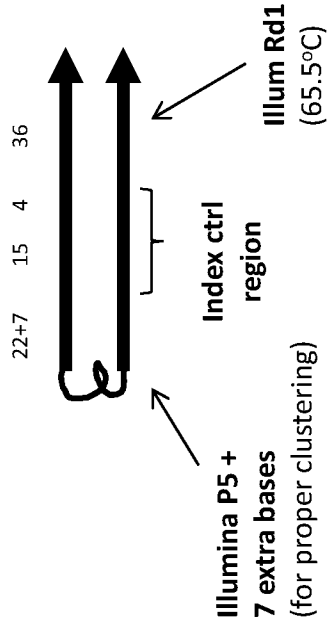

FIG. 10

Ligated Template



dPS PEG1 (2x84=168bp)



dPS u2

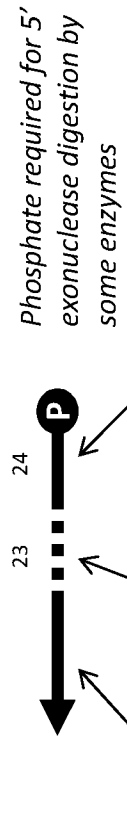

Gene Specific Primer
 Custom Rd2 primer (PS MS8)
 Illumina P7

Other Gene Specific Primers

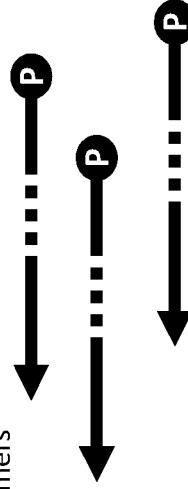

4 base spacer

Index control region:

I1: 5'-CTTCTTCTGCTGCAA CTGA-3'

I2: 5'-TCCCTCCTATCATGG ACAC-3'

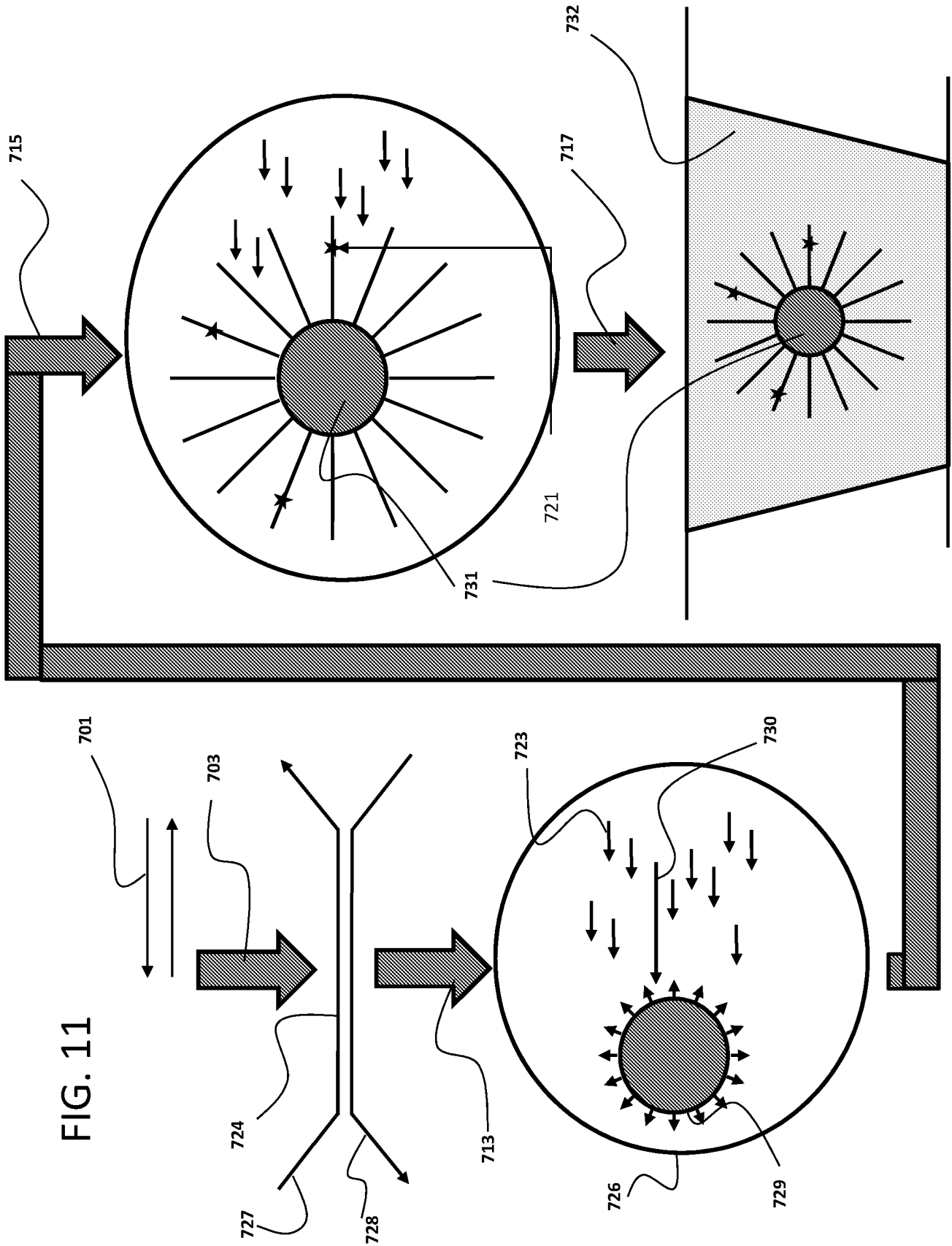
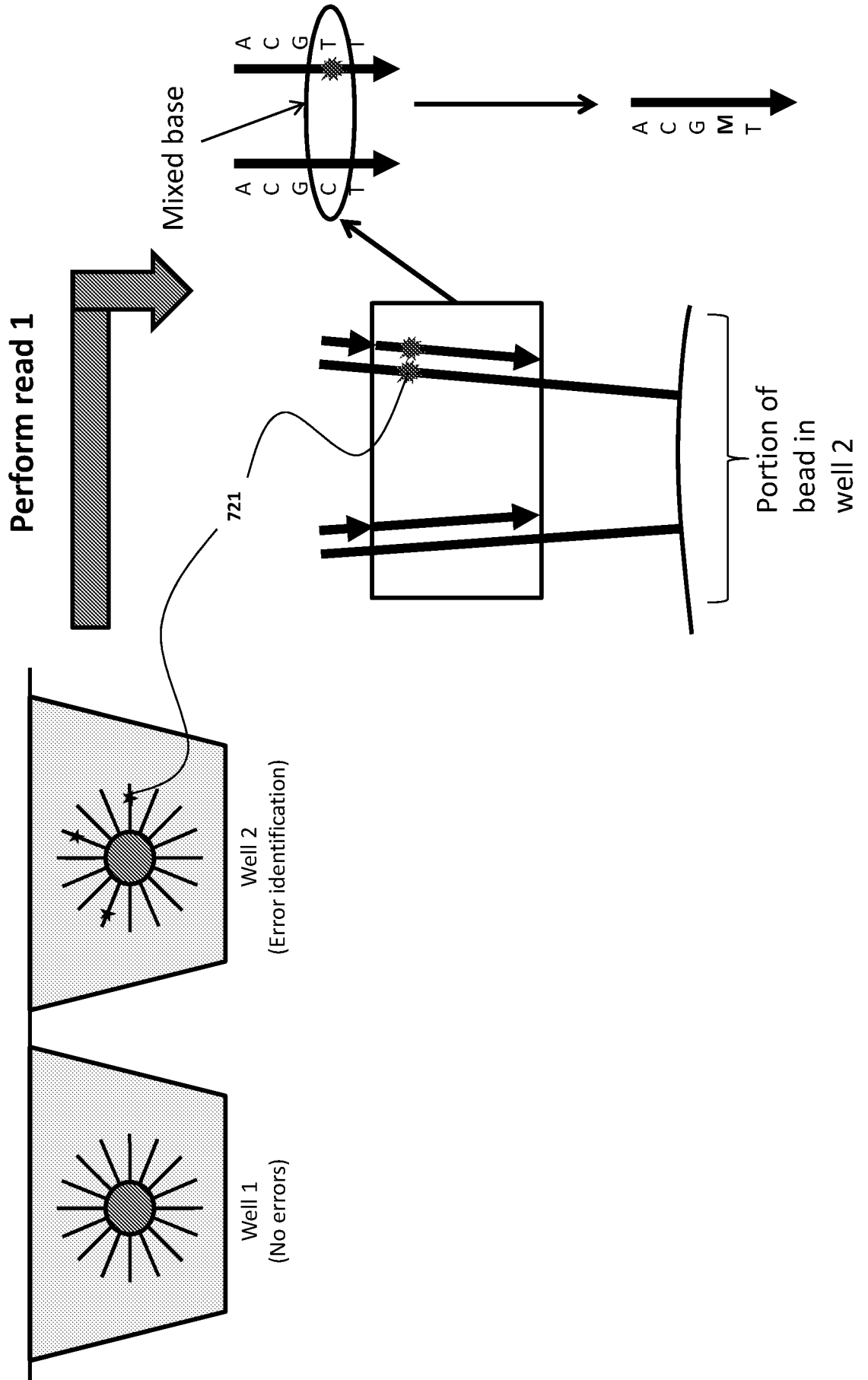

FIG. 11

FIG. 12



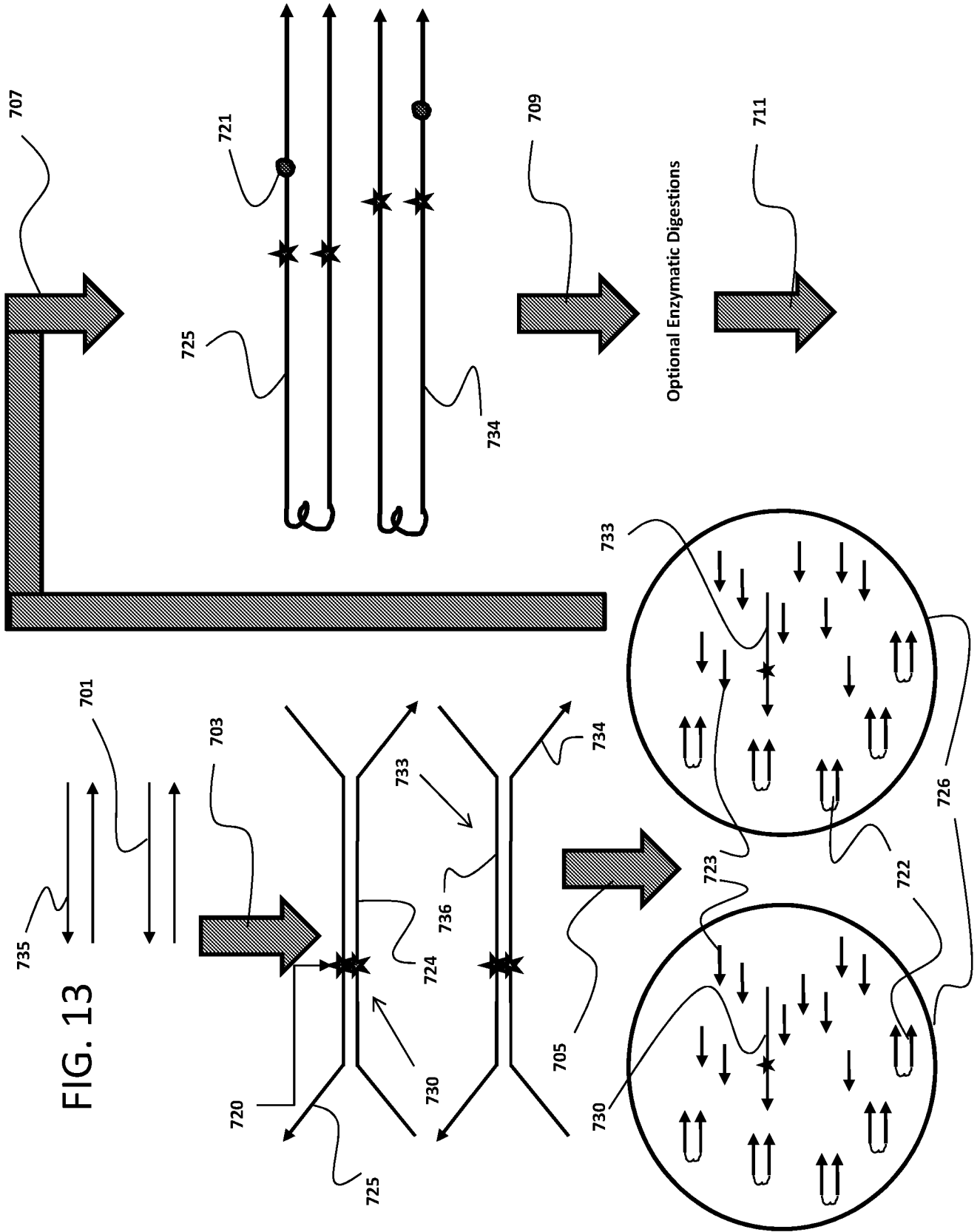

FIG. 13

FIG. 14

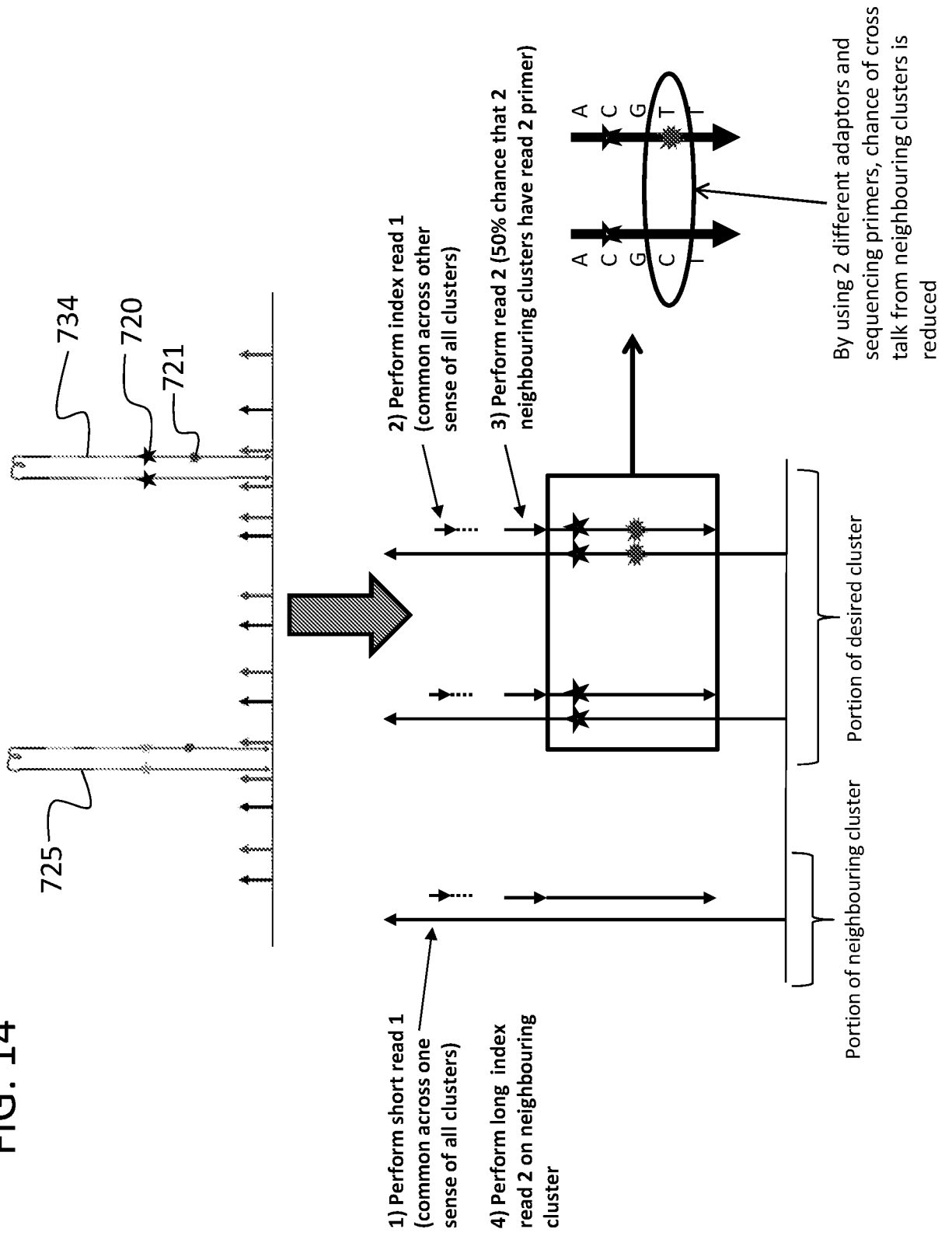
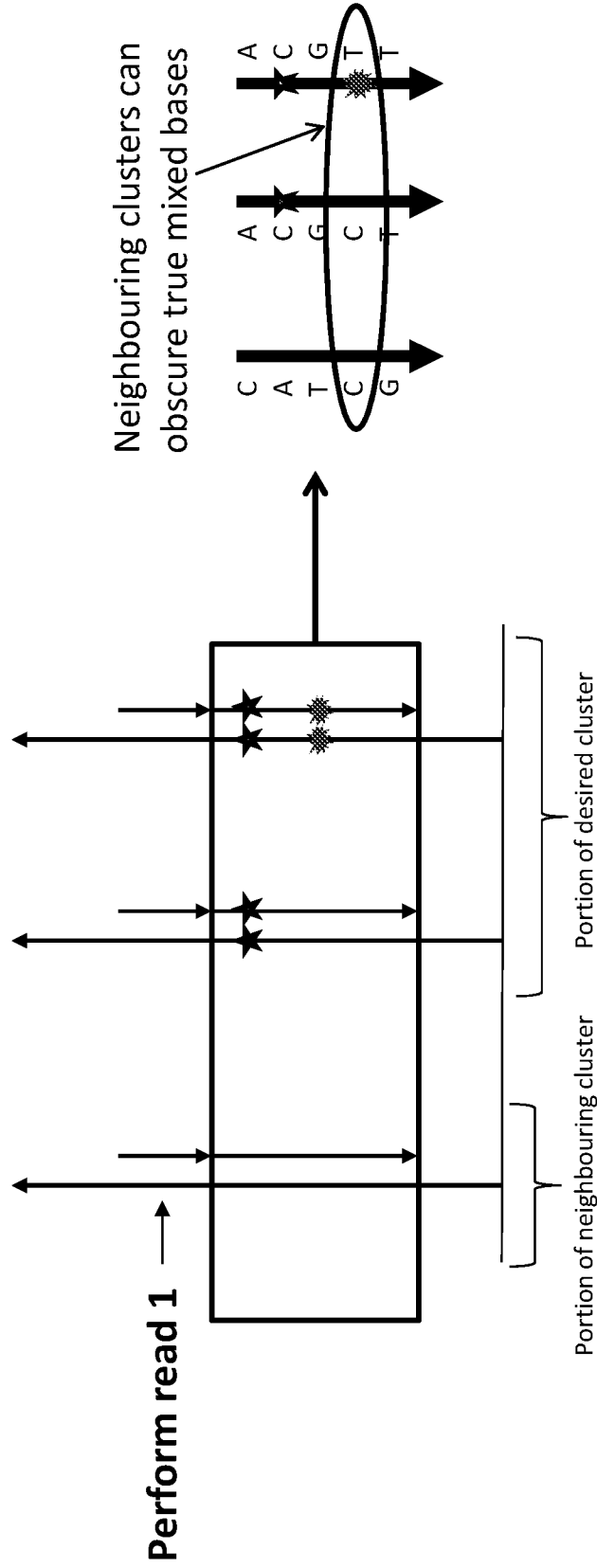

FIG. 15



Prior Art

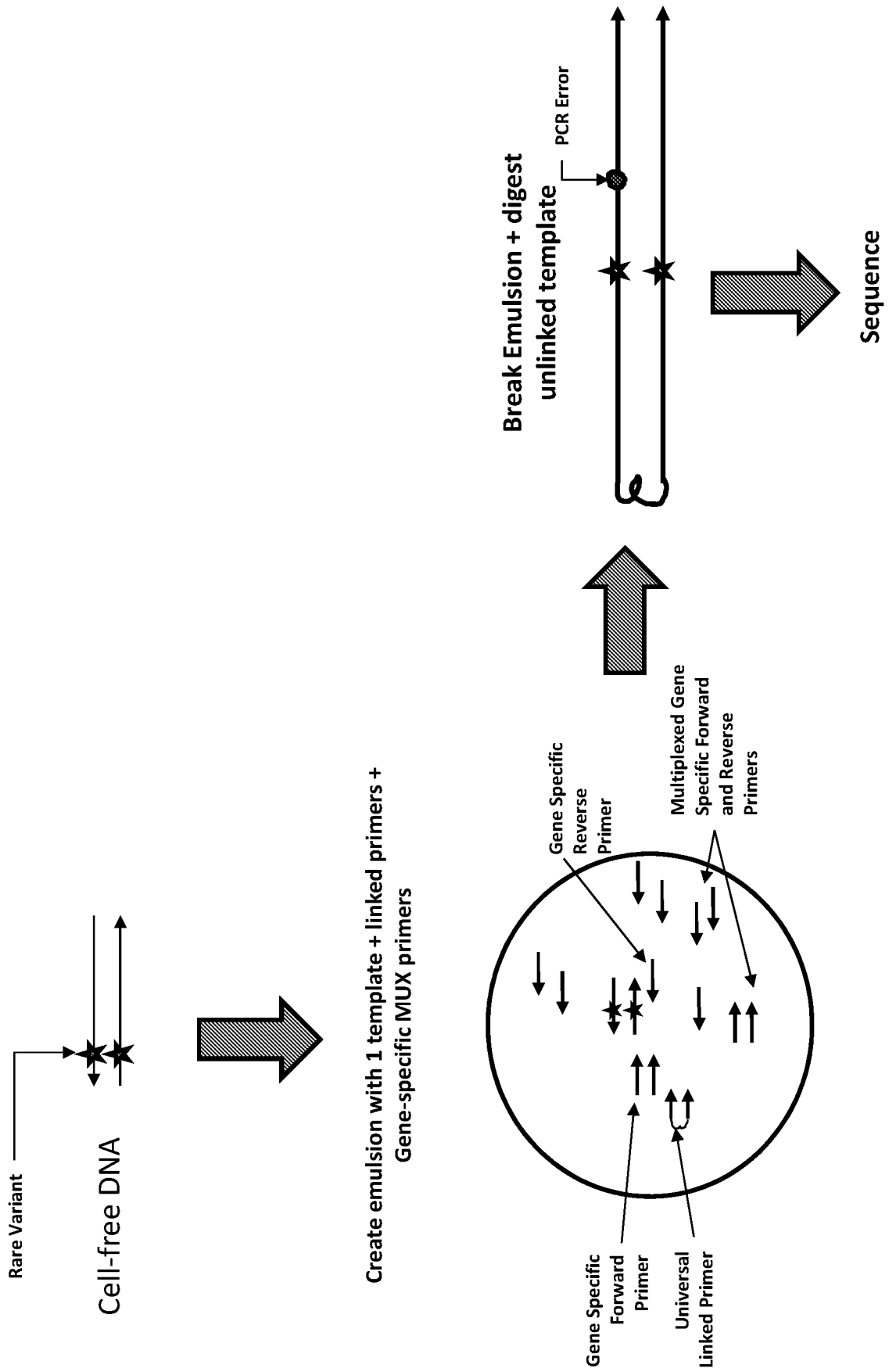

FIG. 16

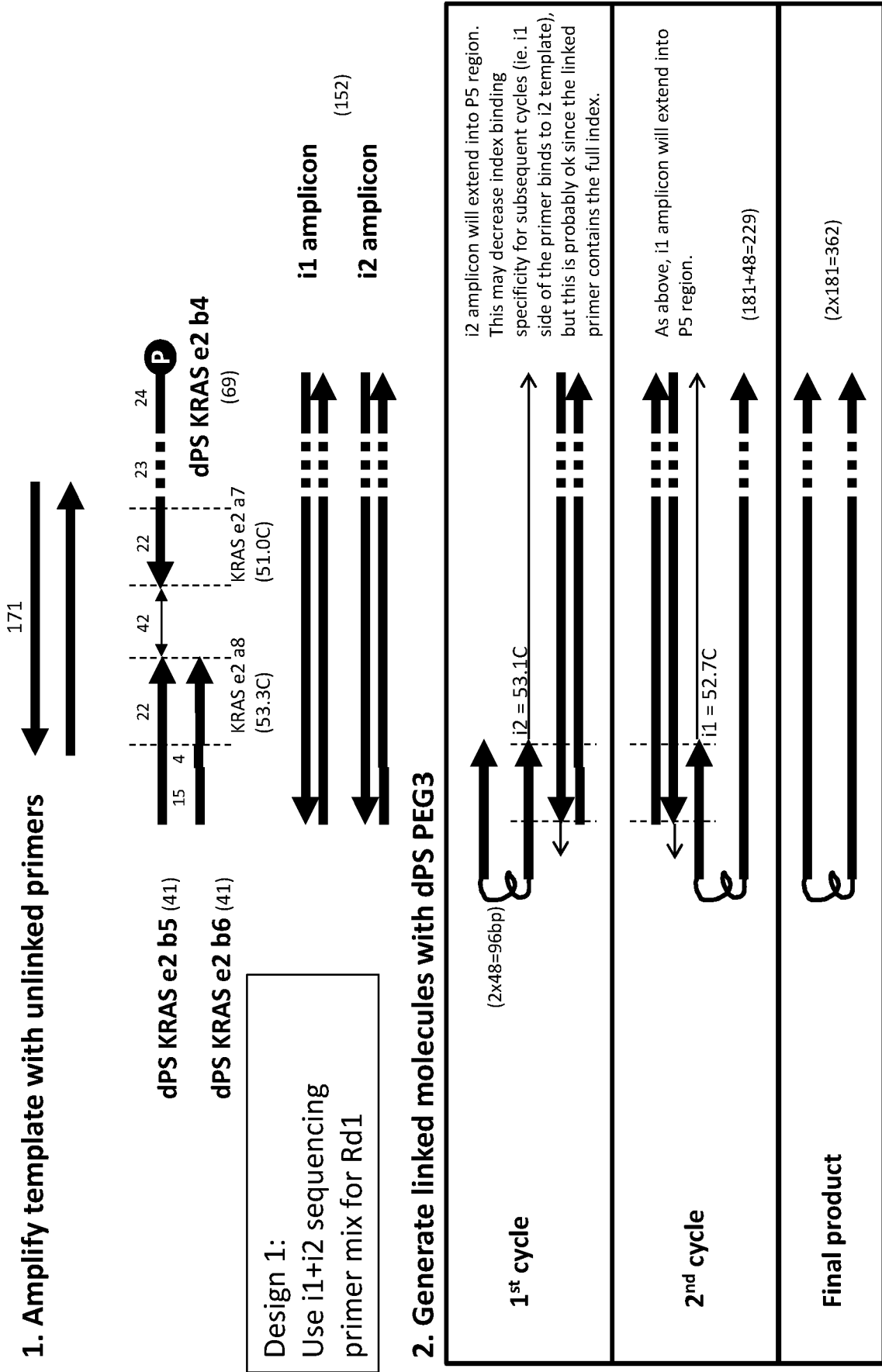

FIG. 17

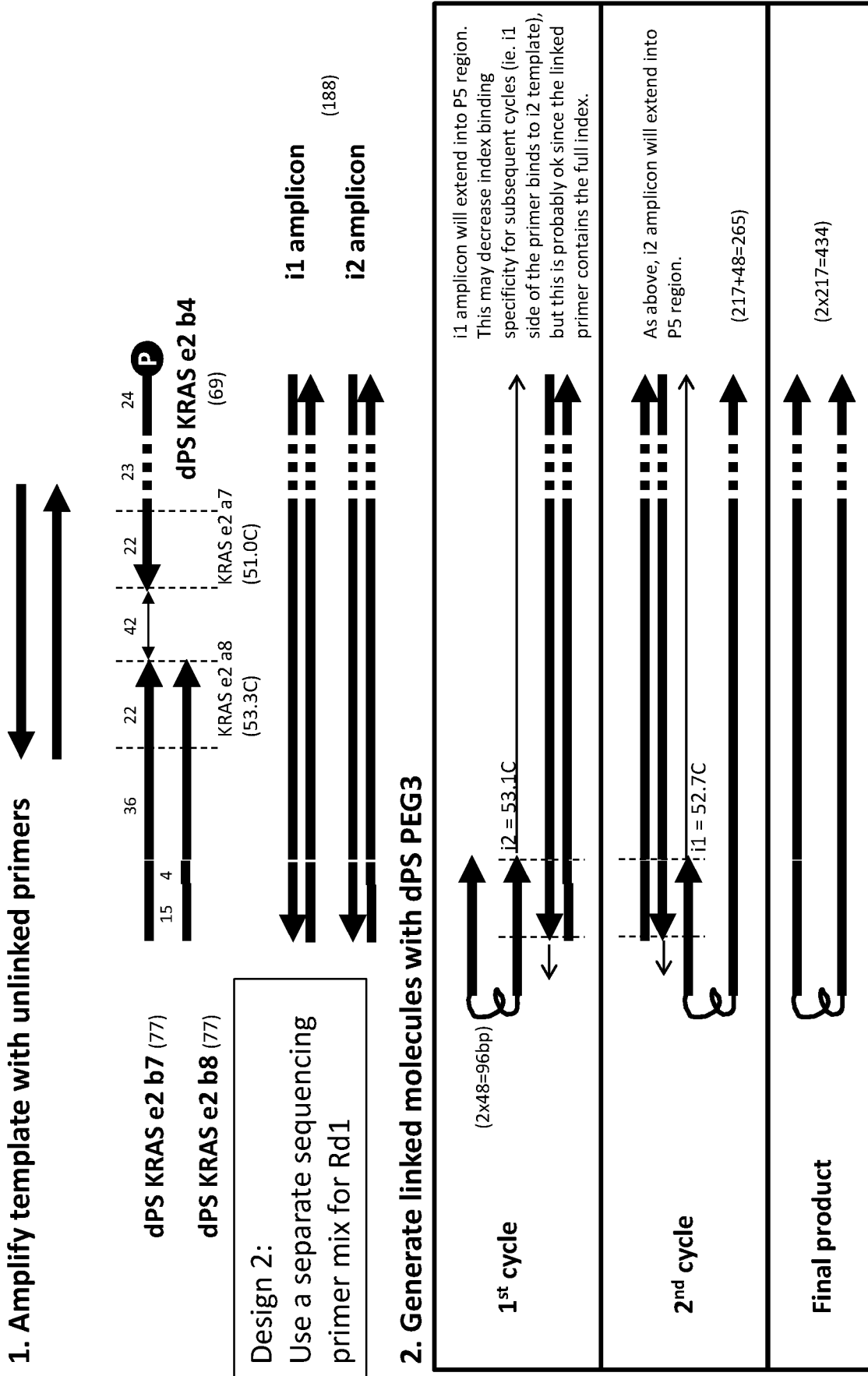

FIG. 18

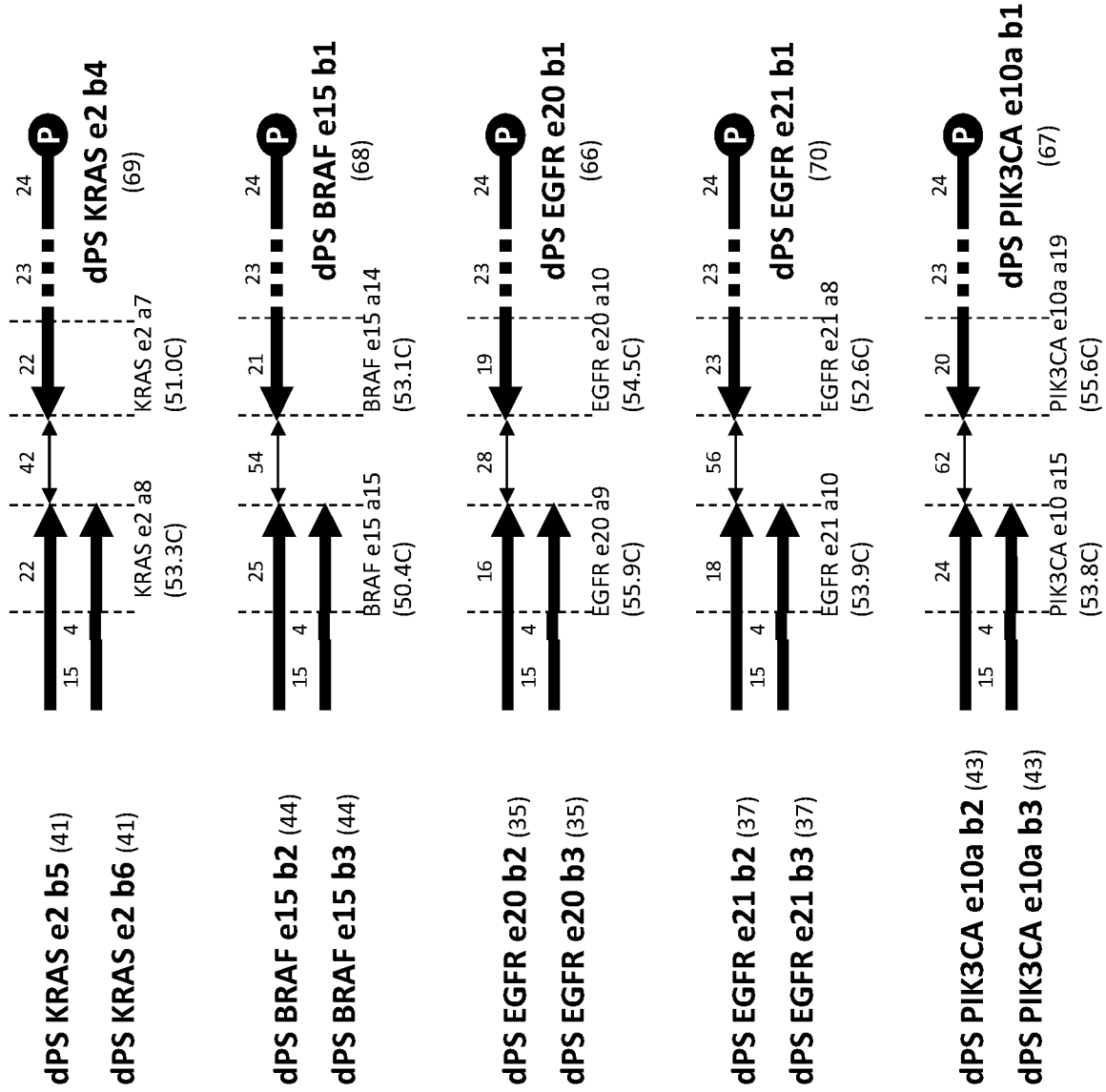

FIG. 19

Index control region: 4 base spacer
 I1: 5'-CTTCTTCTGCTGCAA CTGA-3'
 I2: 5'-TCCCTCCTATCATGG ACAC-3'

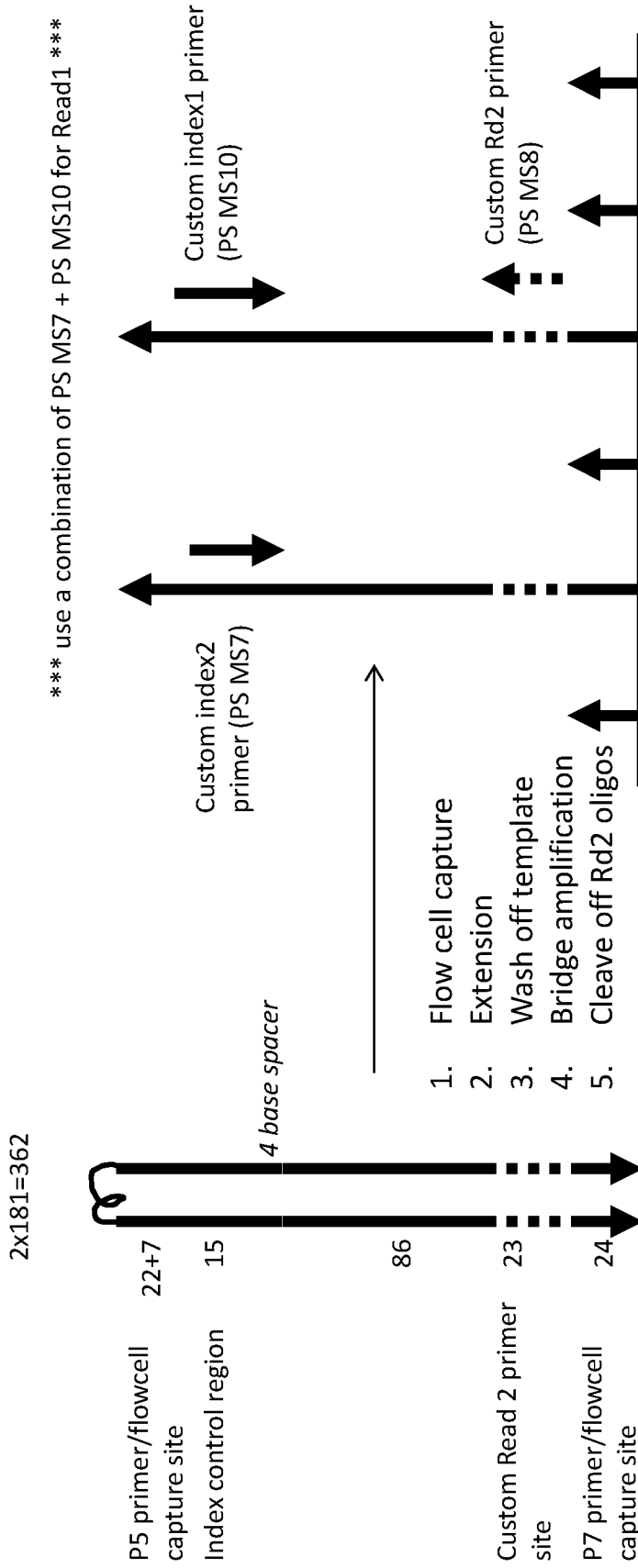

FIG. 20

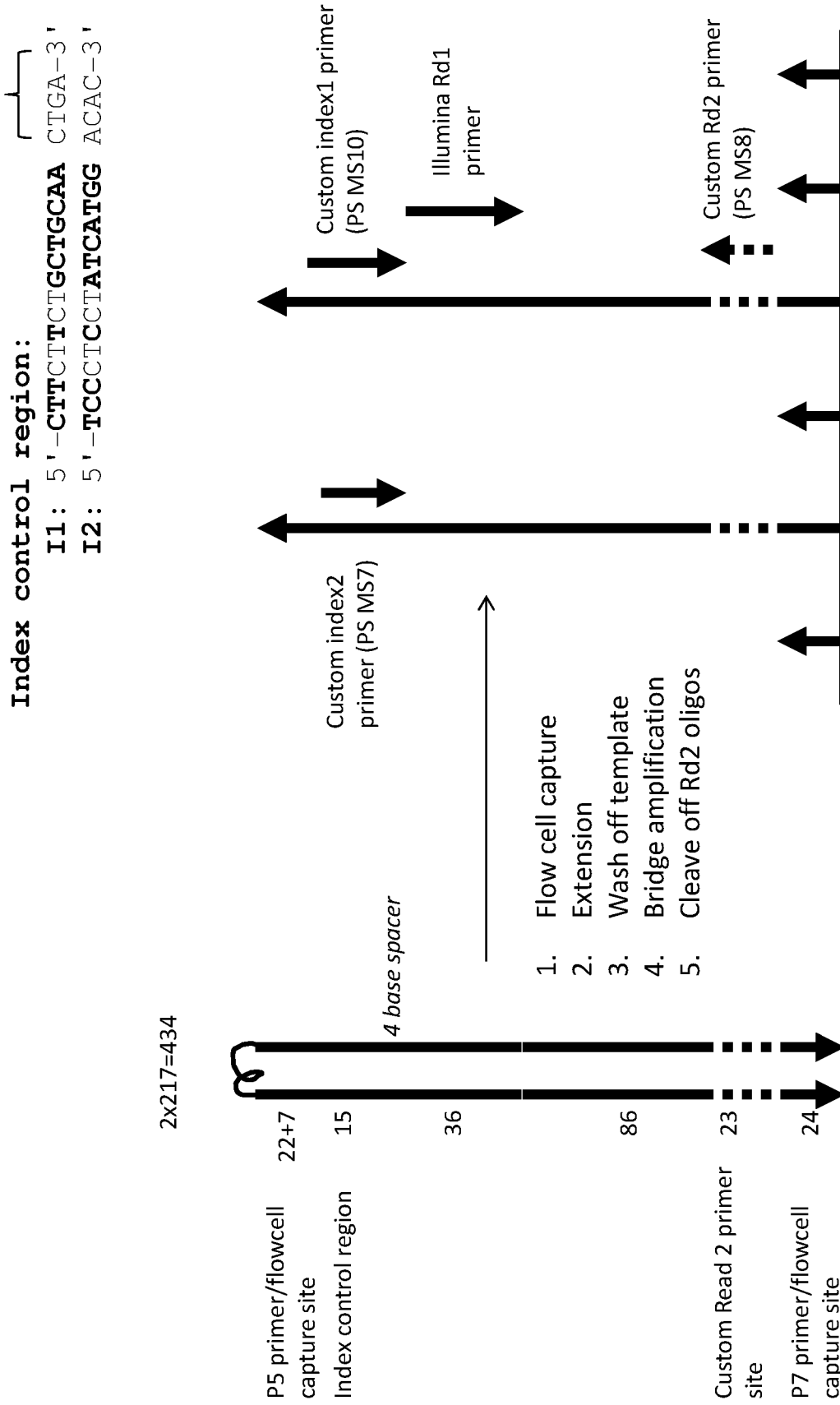

FIG. 21

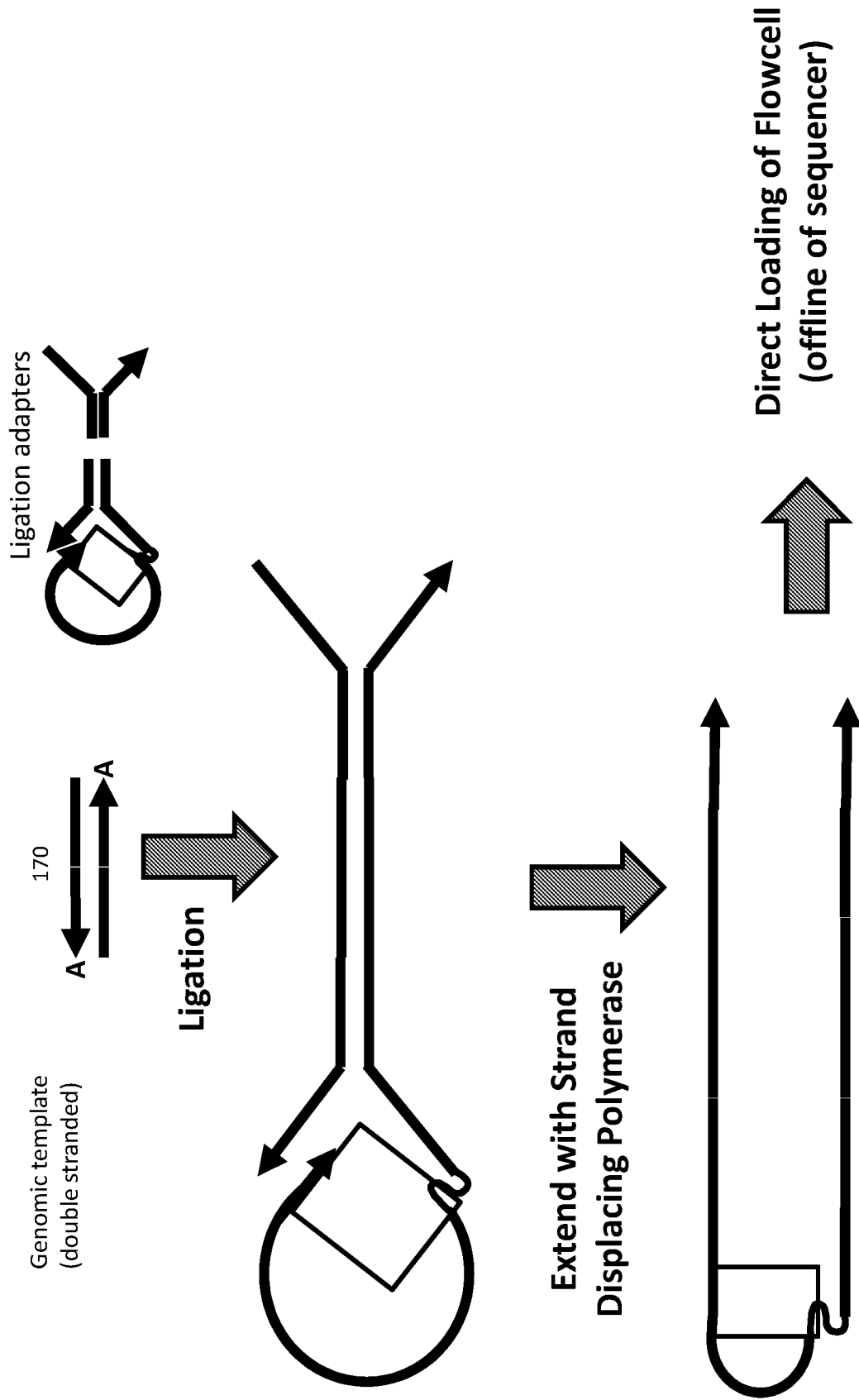

FIG. 22A

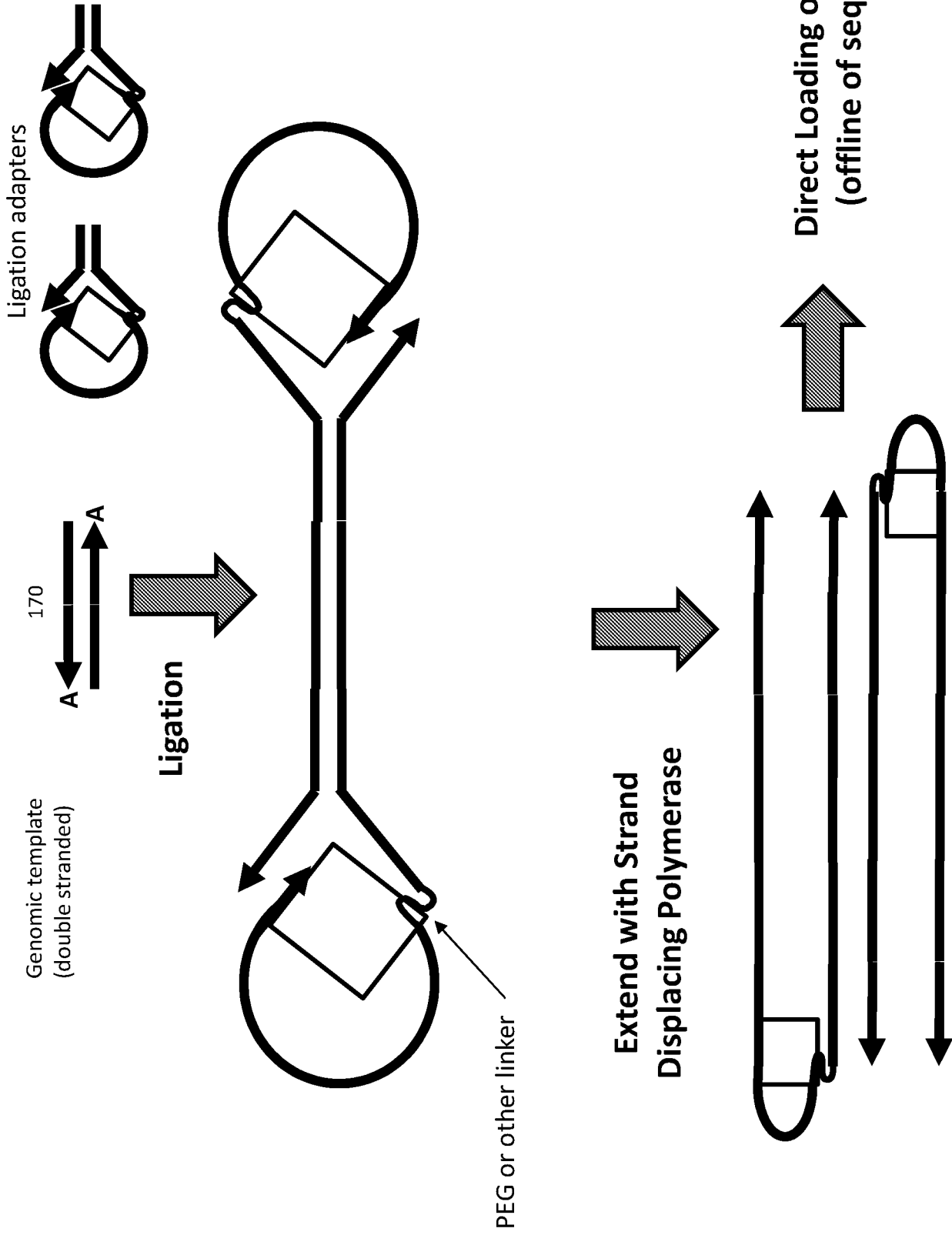

FIG. 23A

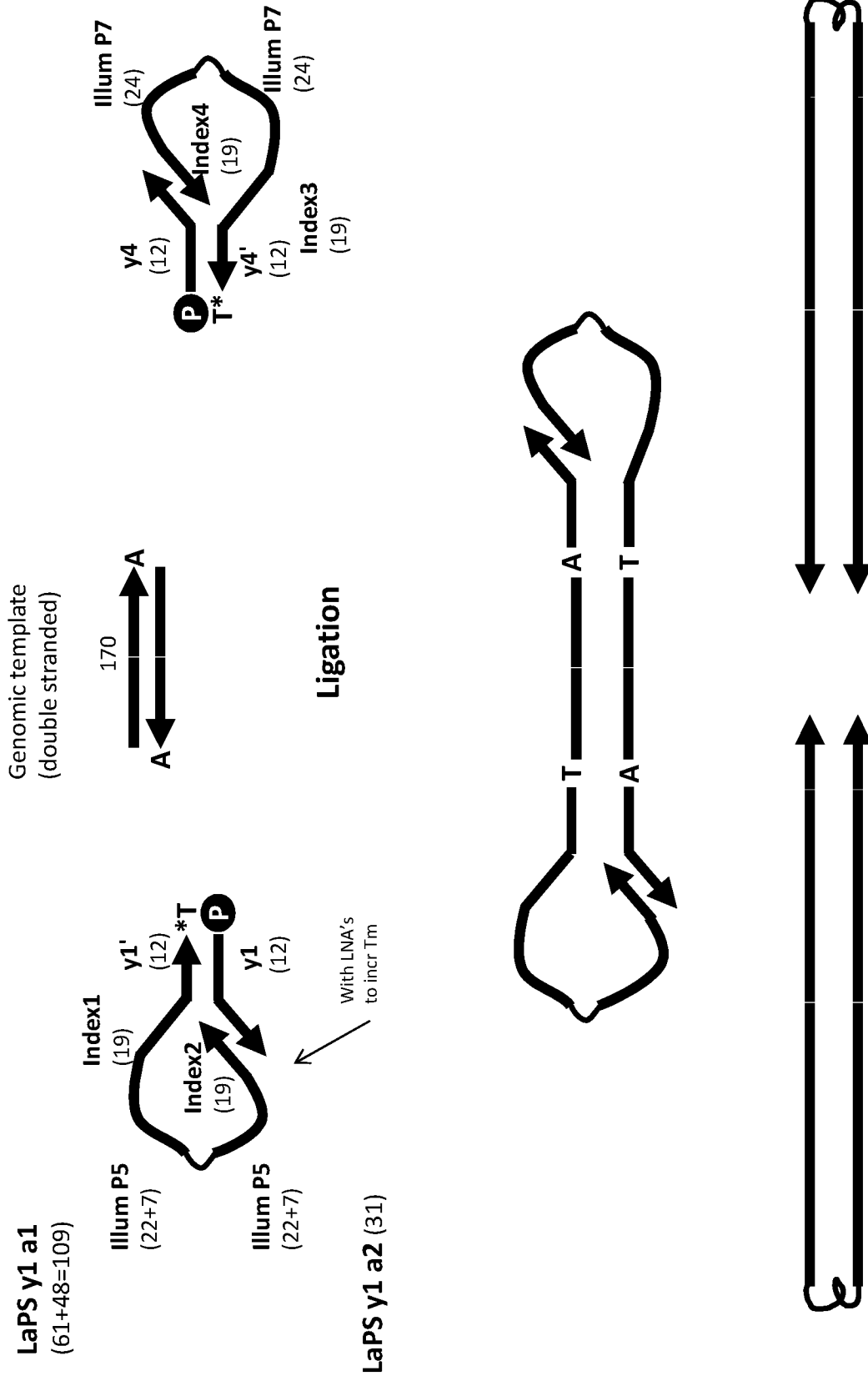

FIG. 23B

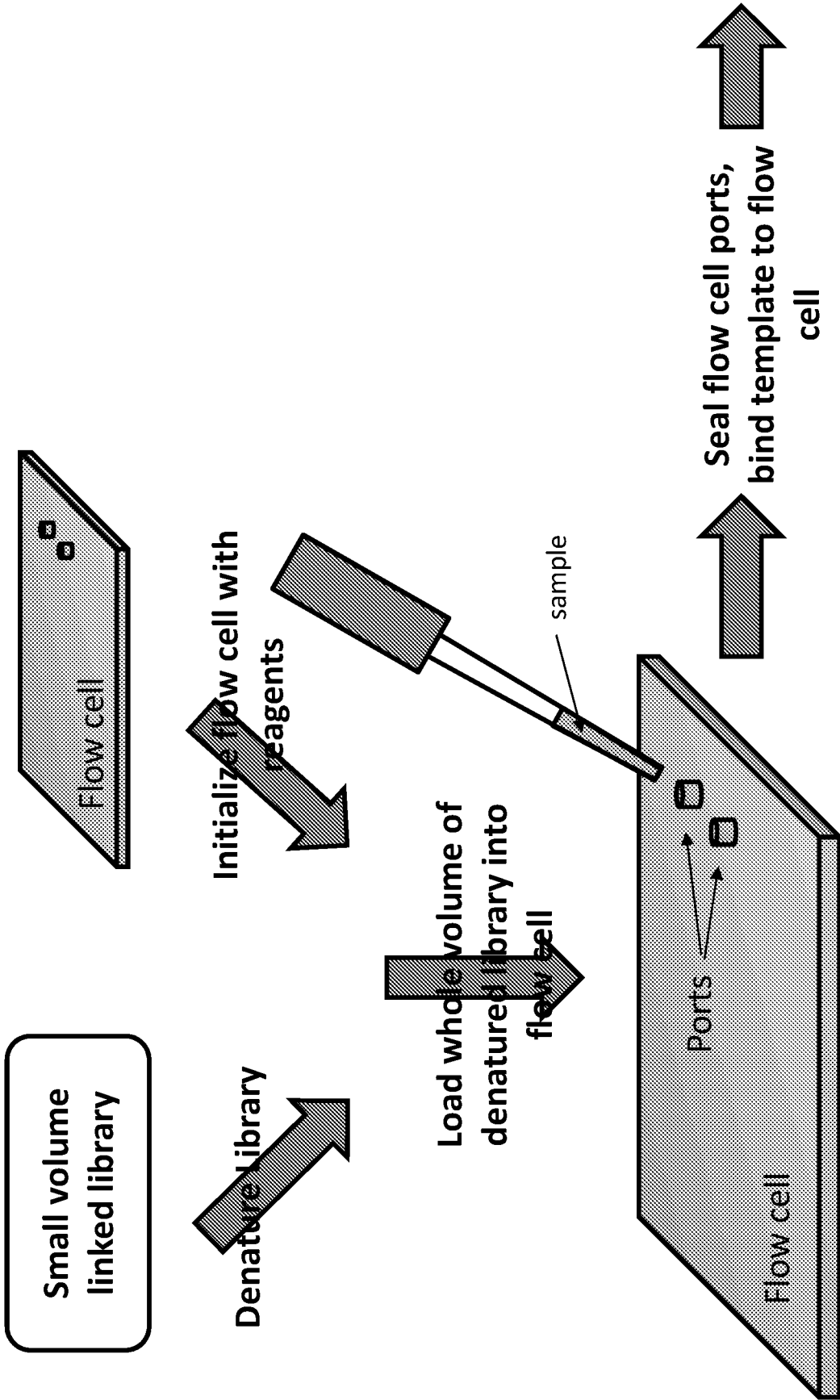

FIG. 24A

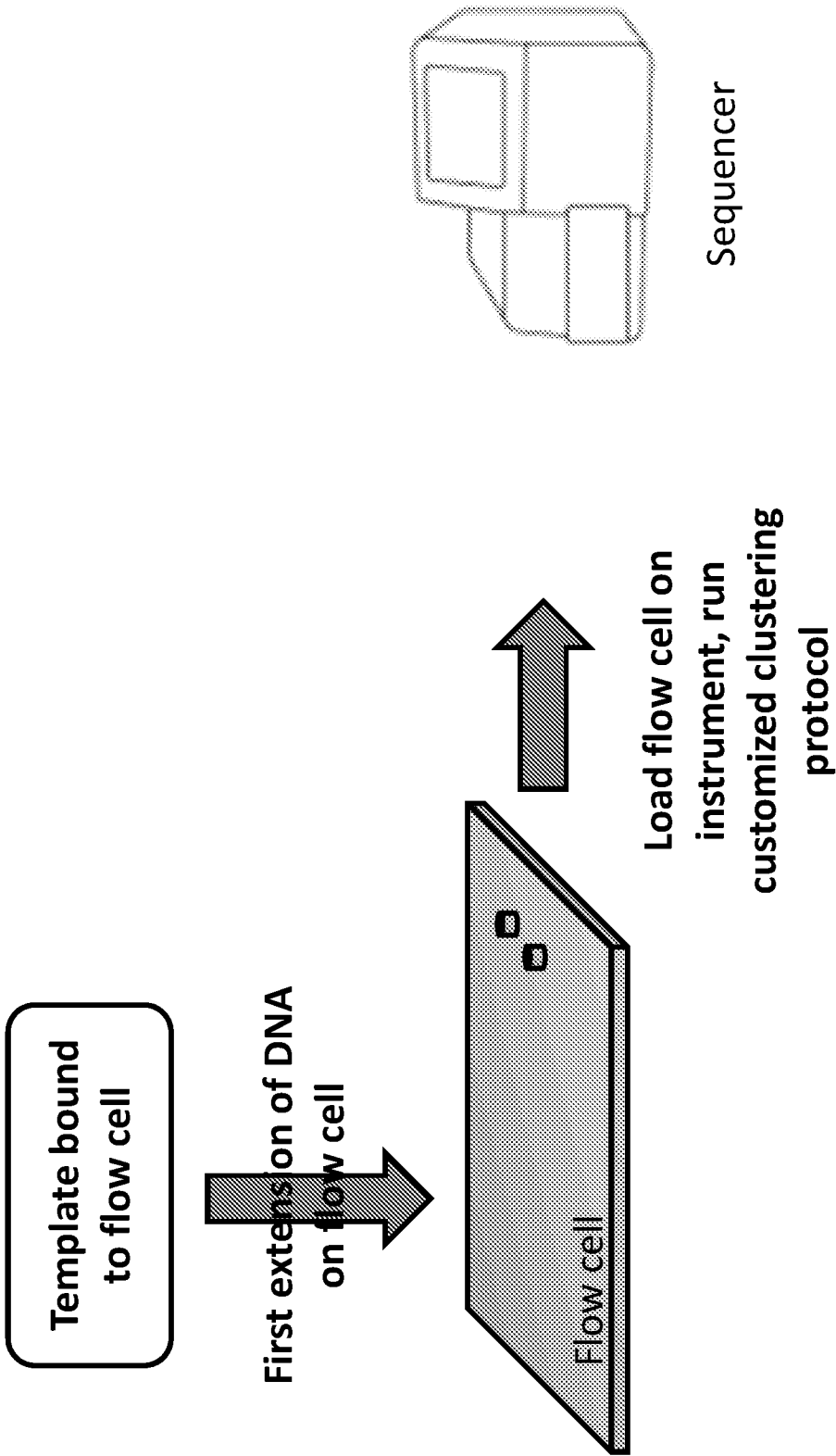

FIG. 24B

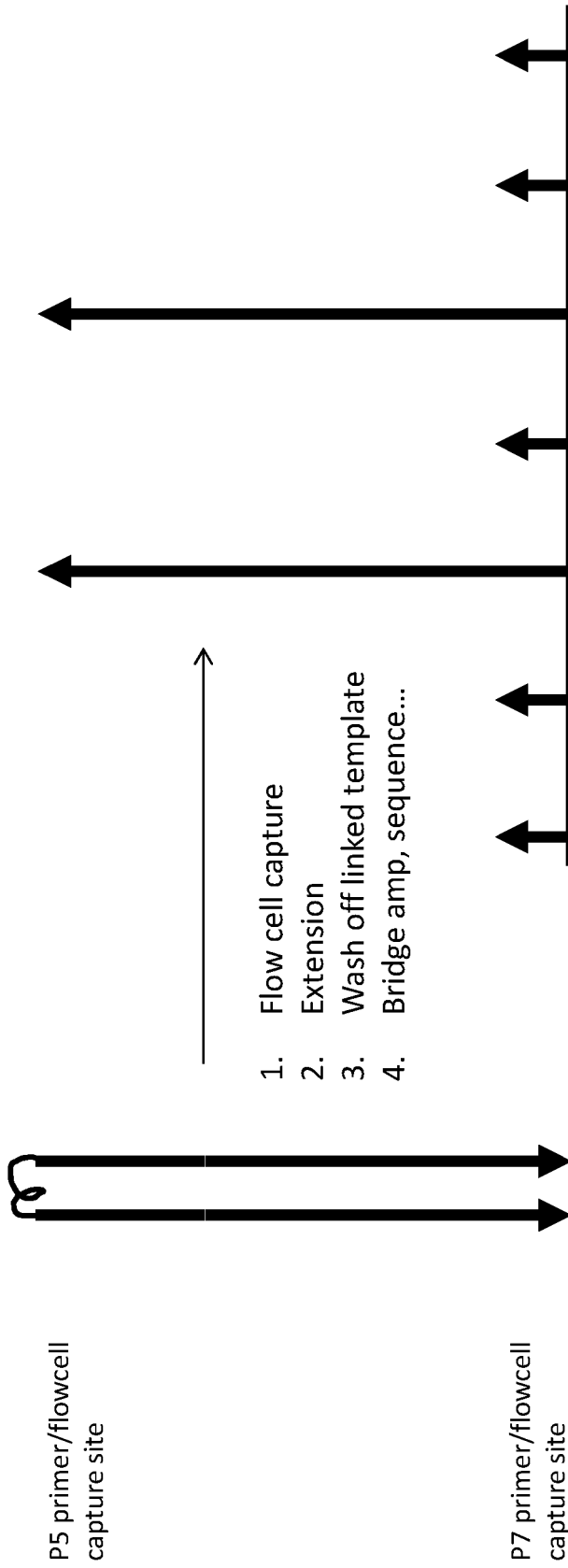
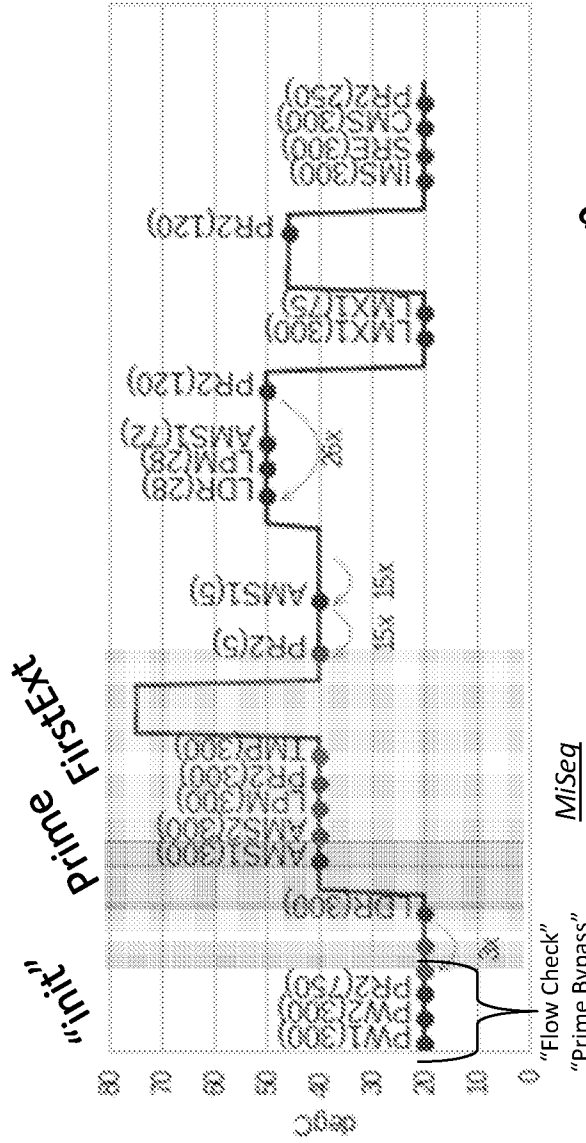

FIG. 25

Default protocol



Off-line protocol

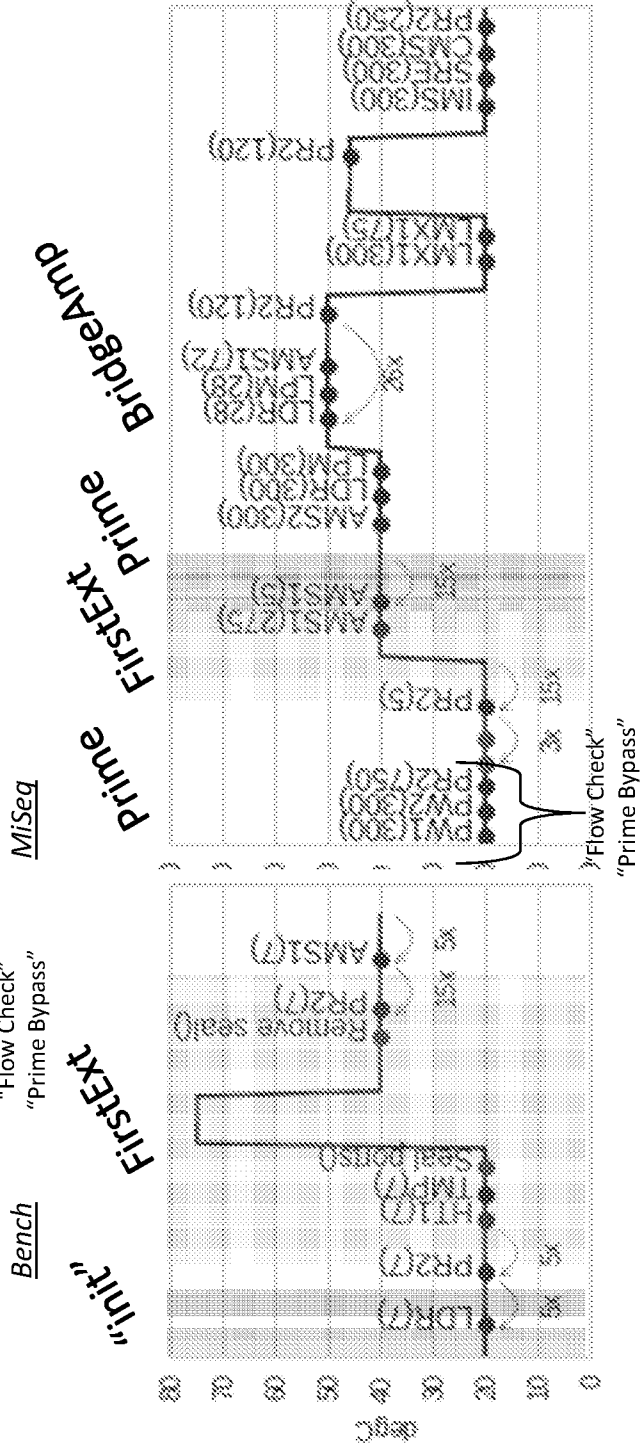

FIG. 26

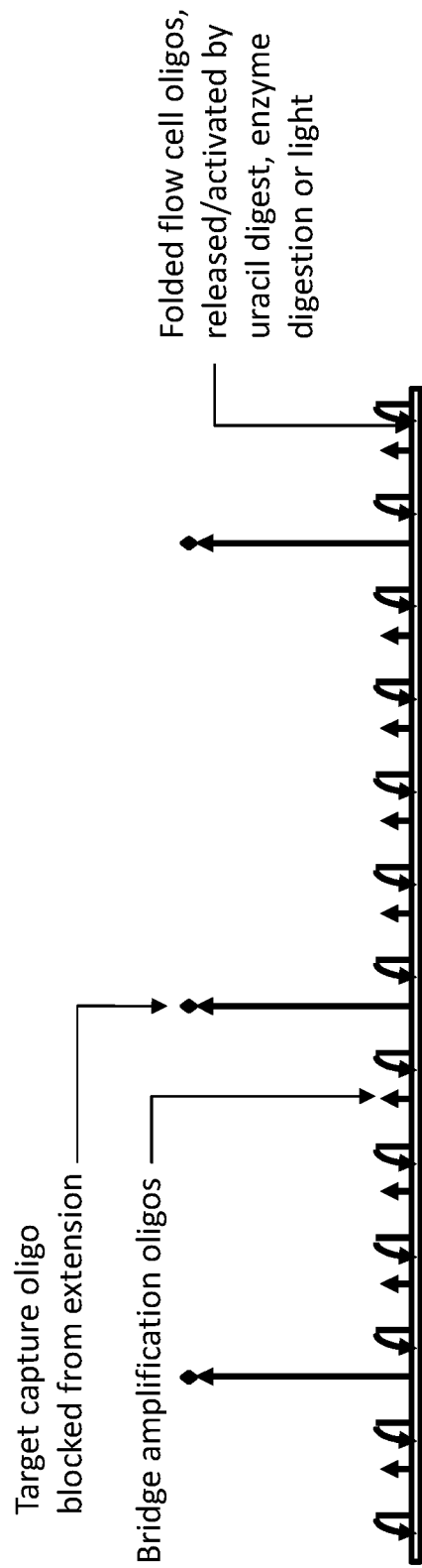

FIG. 27

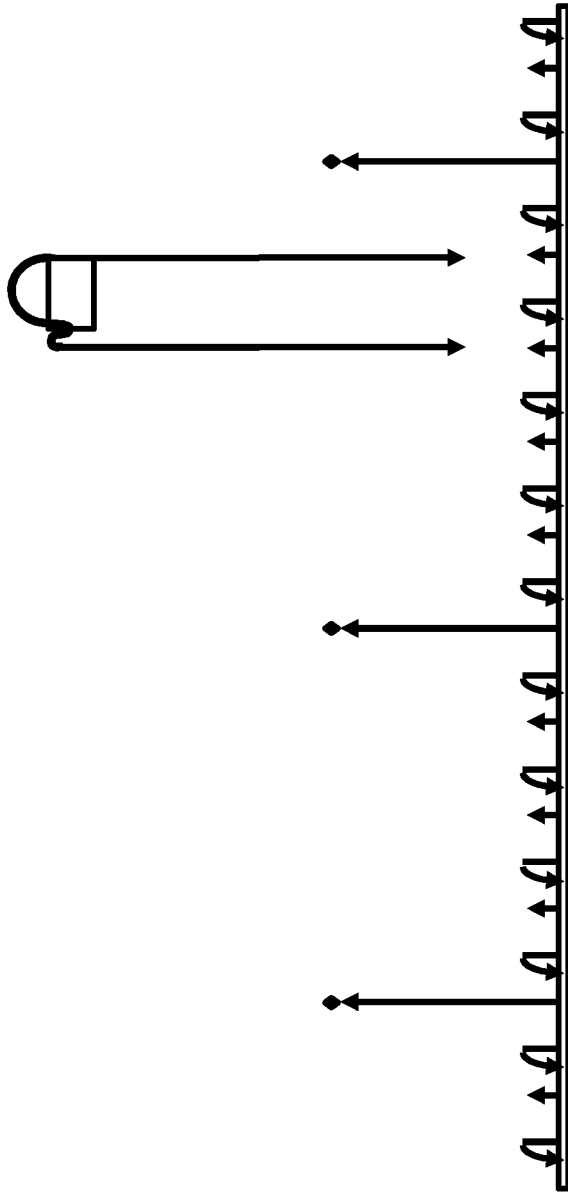

FIG. 28A

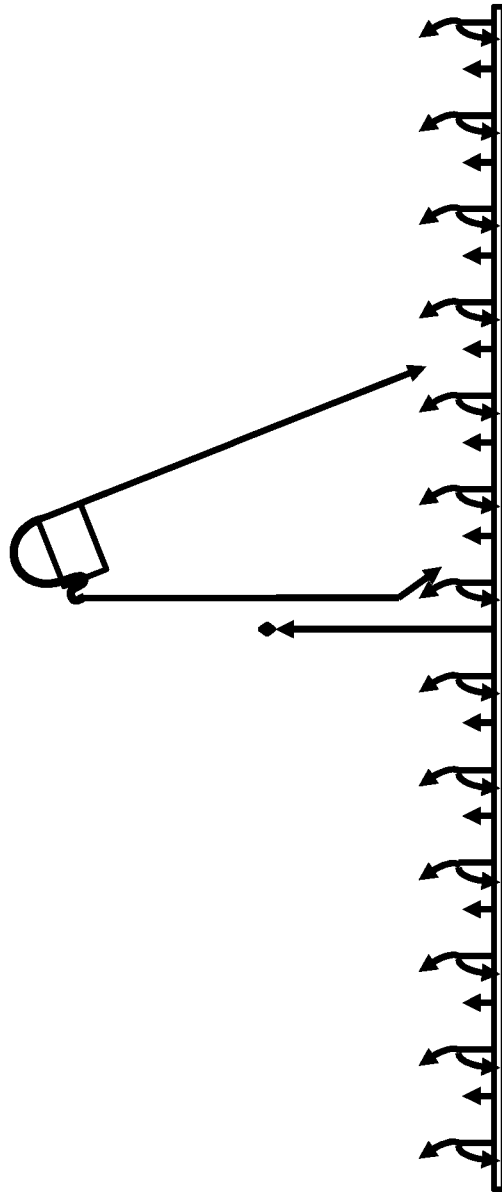

FIG. 28B

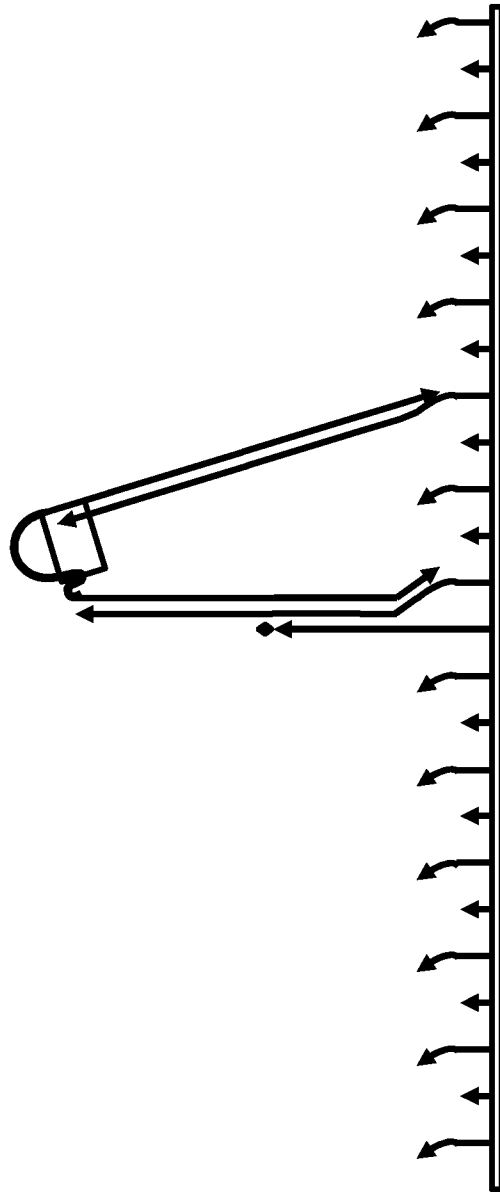

FIG. 28C

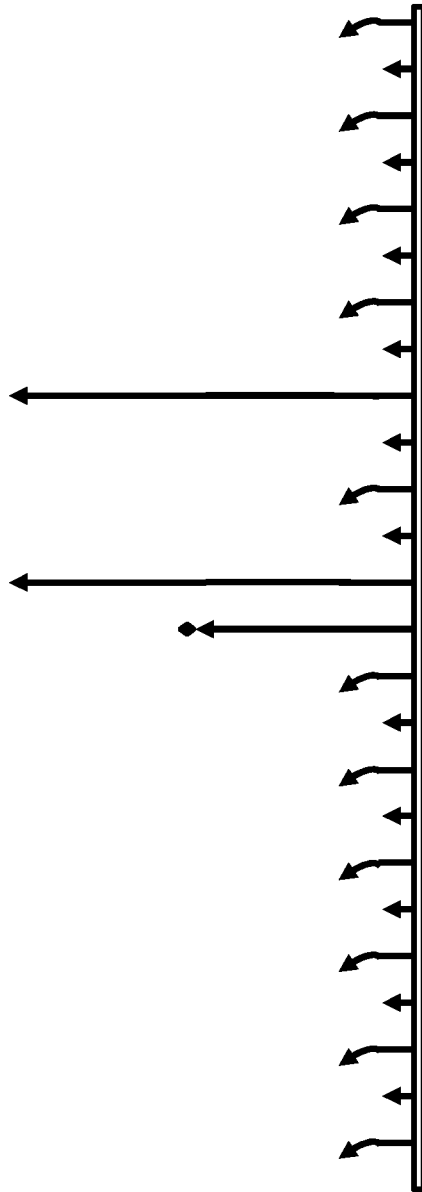

FIG. 28D

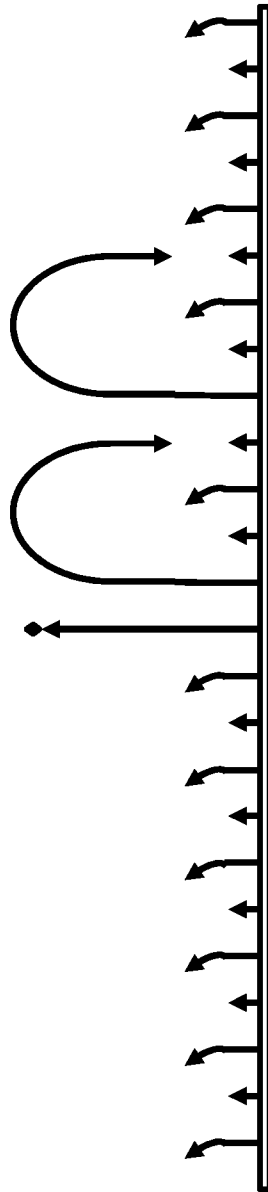
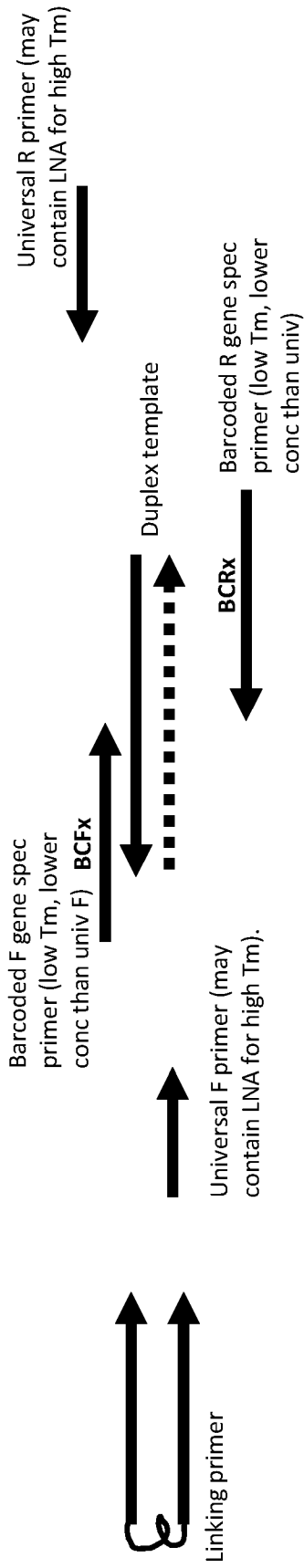
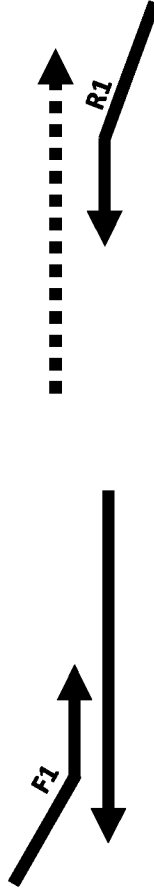

FIG. 28E



Cycle 1

Low annealing temp (Allow barcoded primers to bind template)



Cycle 2

Low annealing temp

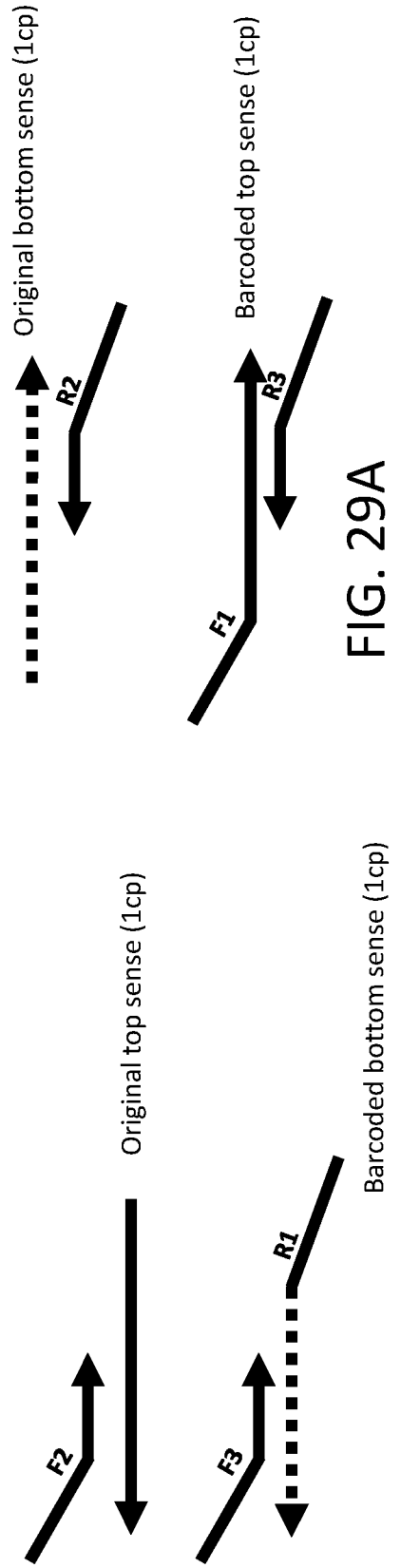
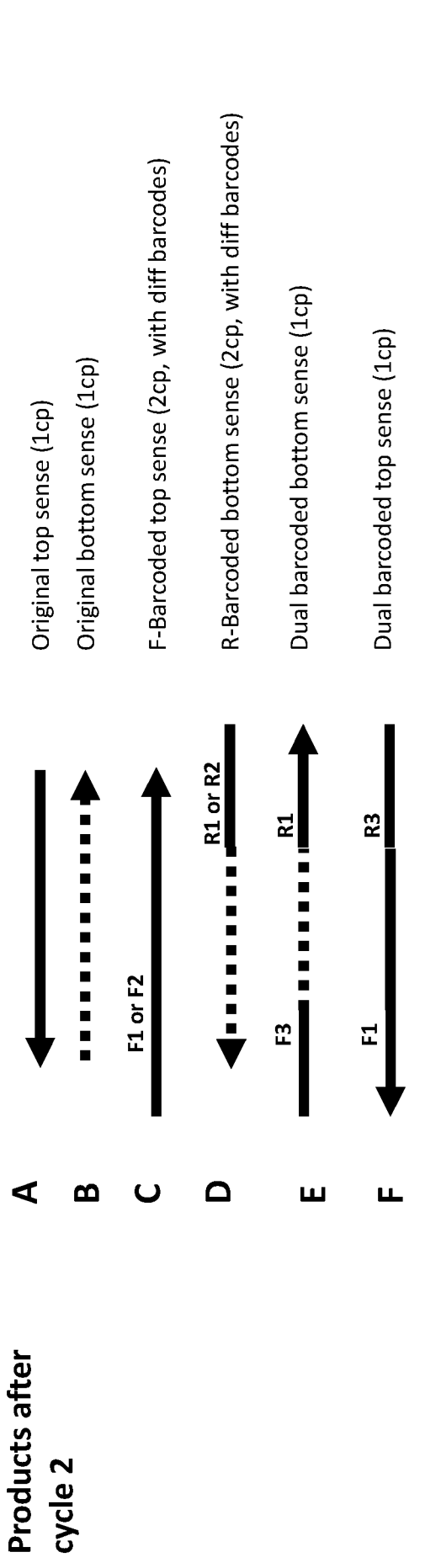

FIG. 29A



Cycle 3

Low annealing temp. Allow 1st cycle of univ primer binding.

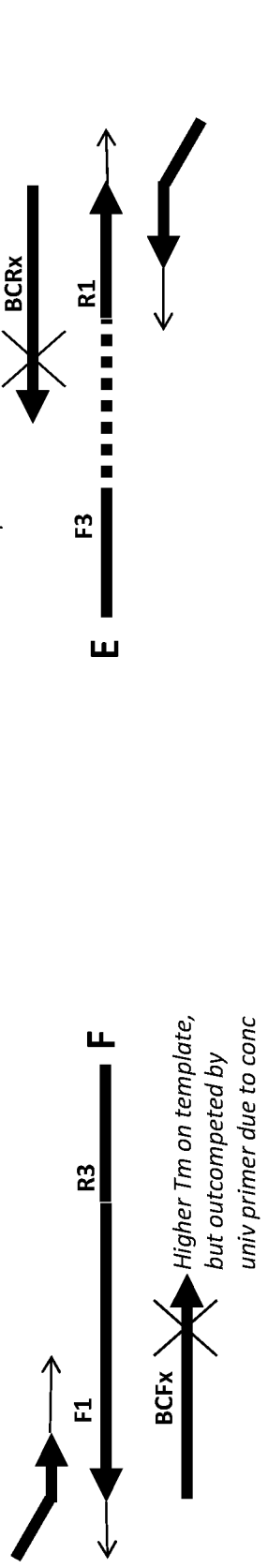
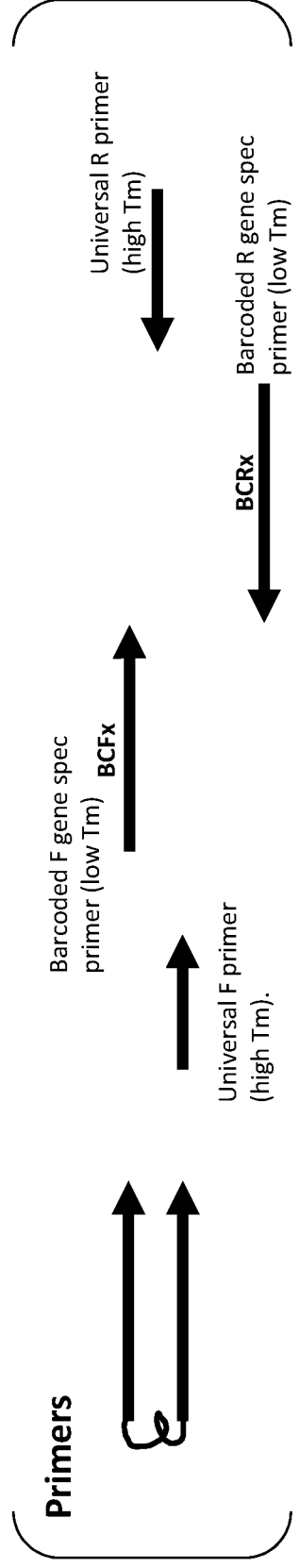
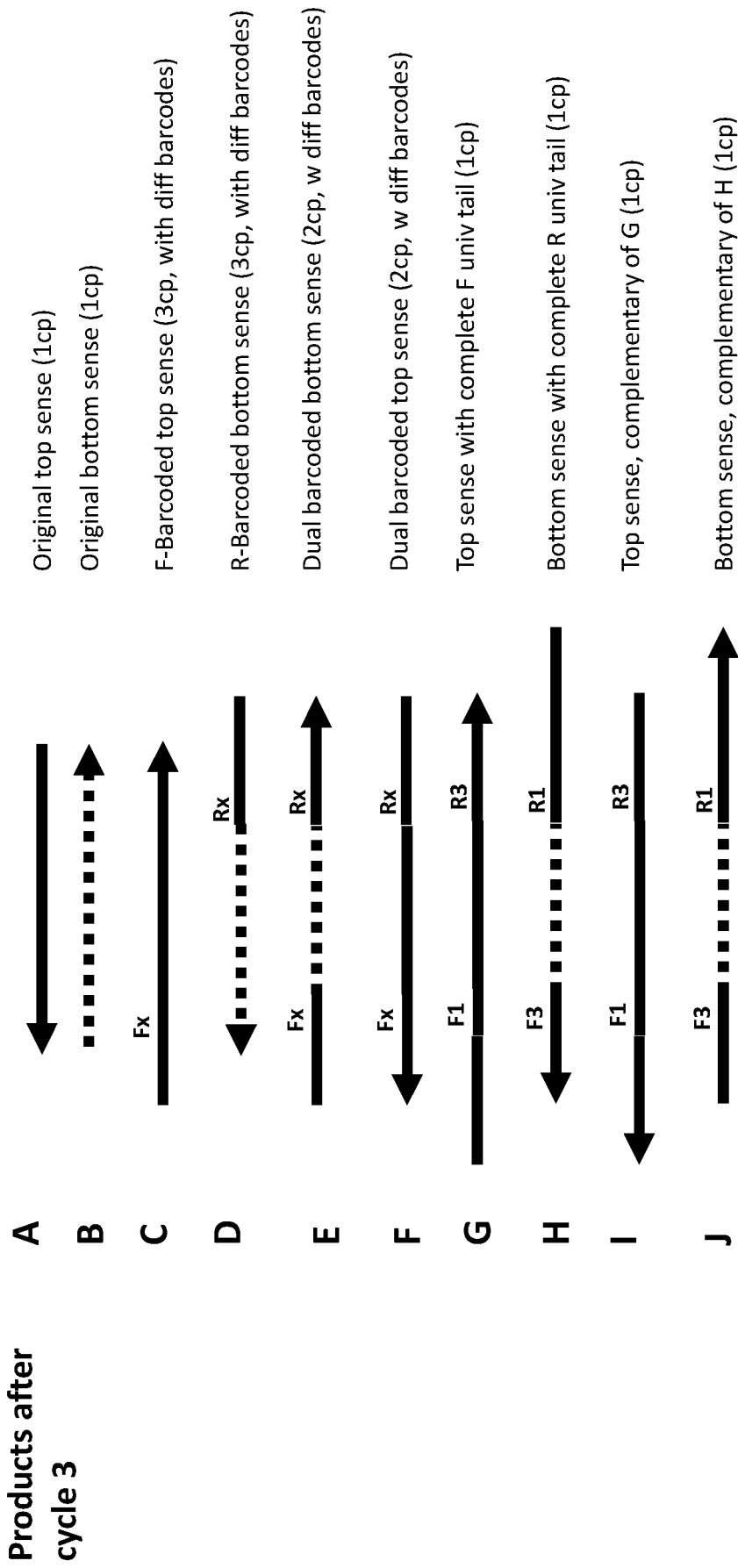

FIG. 29B





Cycle 4

Low annealing temp. Allow 2nd cycle of univ primer binding.



FIG. 29C

Cycle 5 - X

High annealing temp. Only allow binding of univ primers to amplicons with full univ tail



Last few cycles

Low annealing temp. Allow linking of amplified strands via a portion of the F univ tail

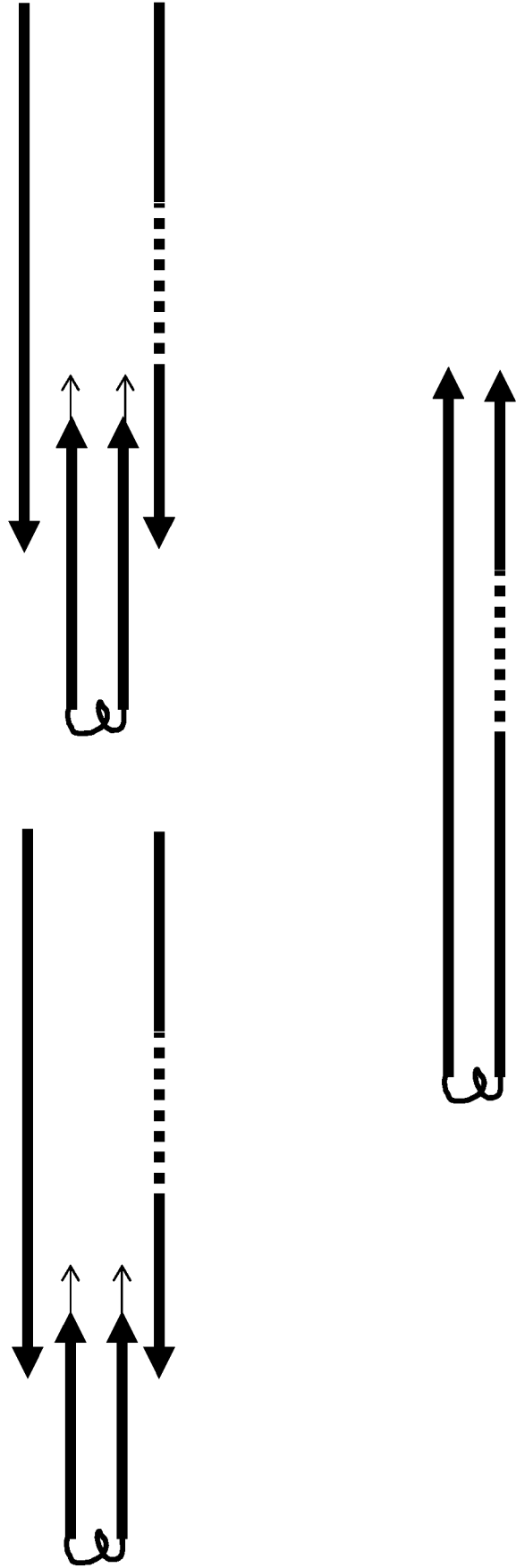

FIG. 29D

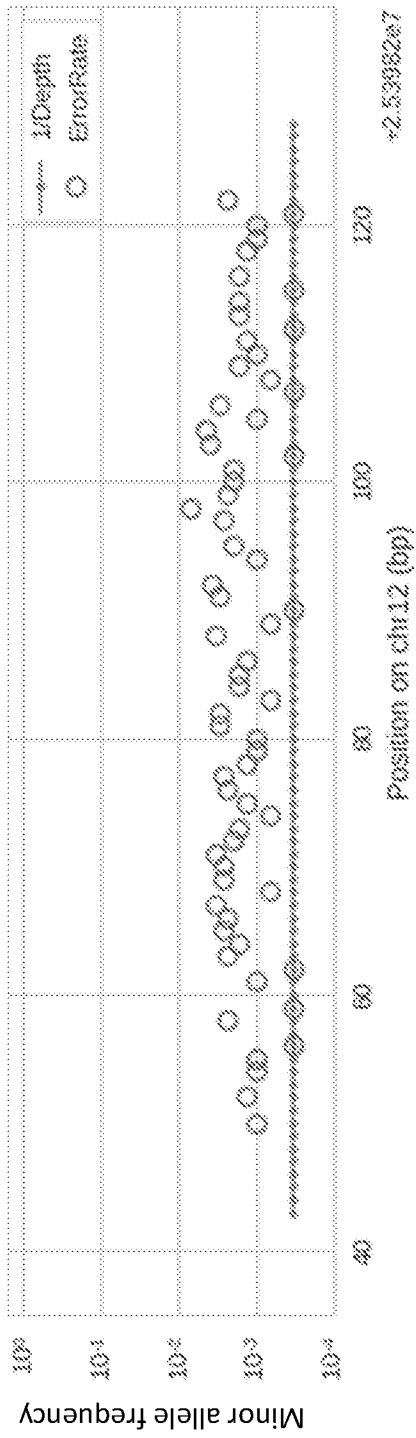

FIG. 30

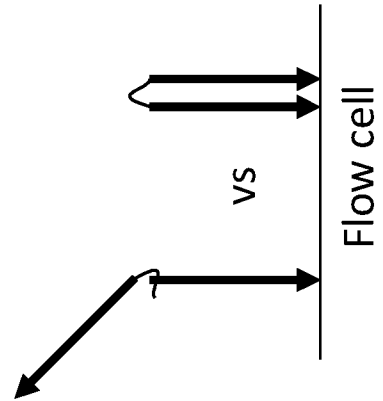

FIG. 31

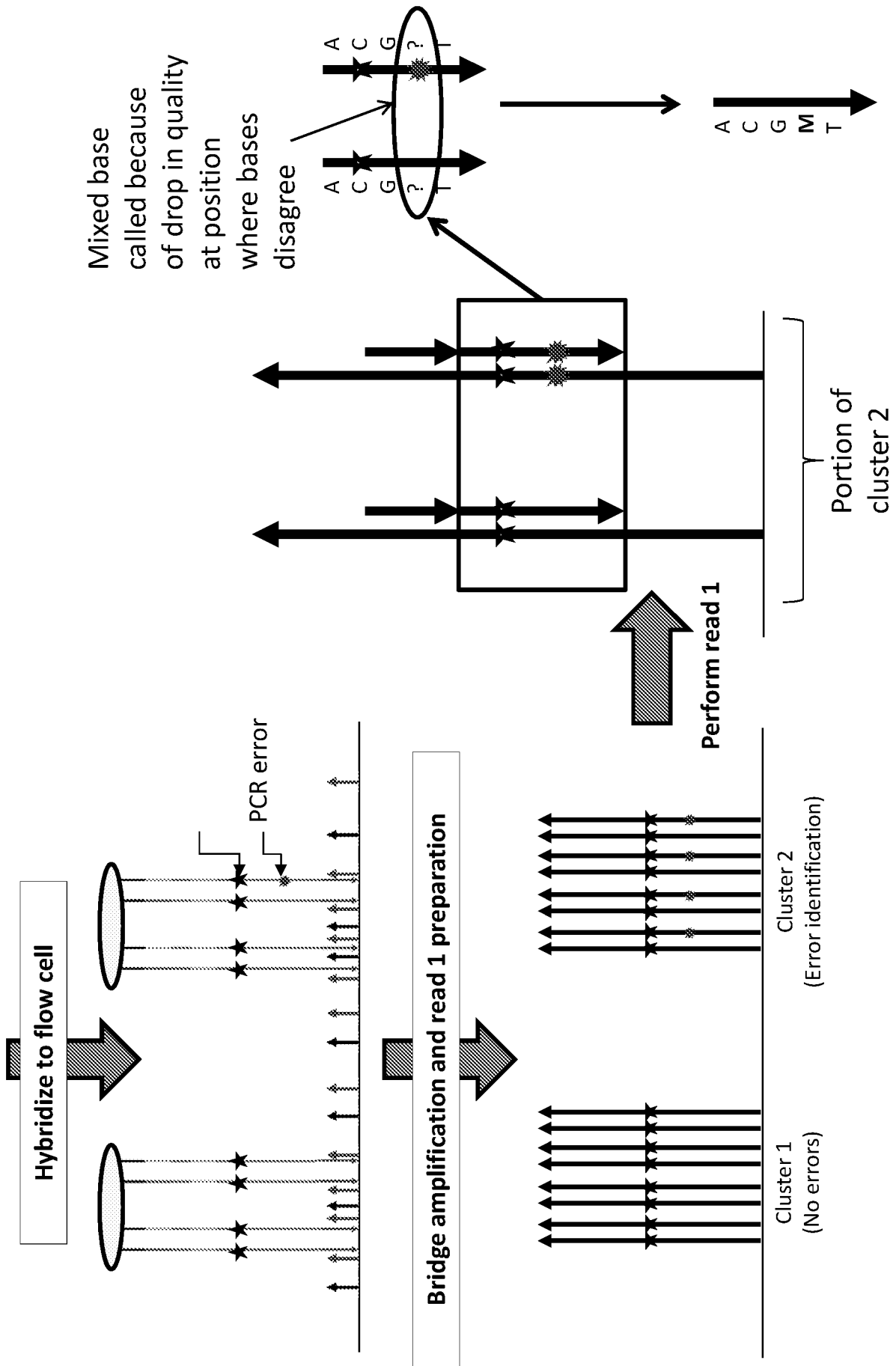

FIG. 32

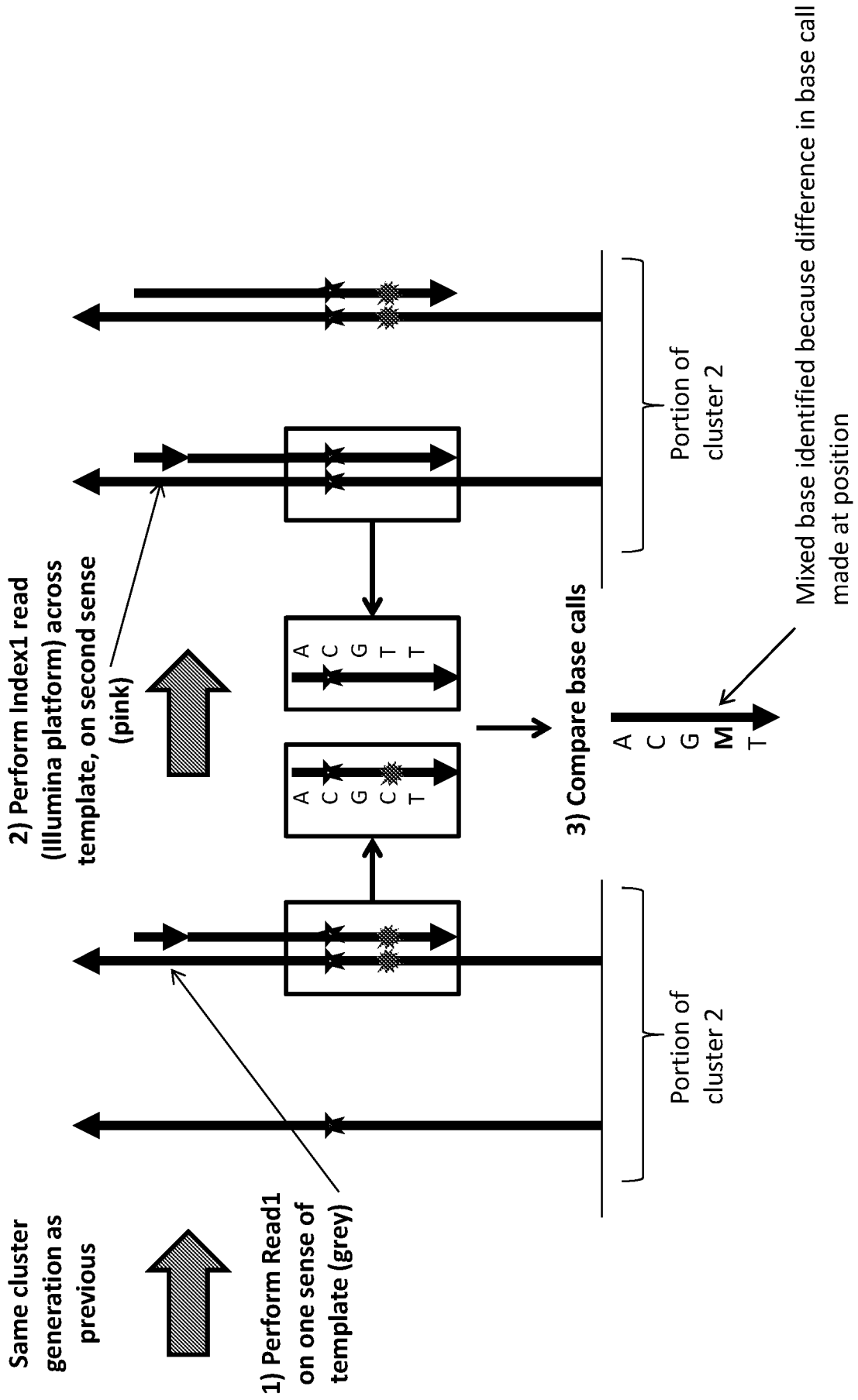

FIG. 33

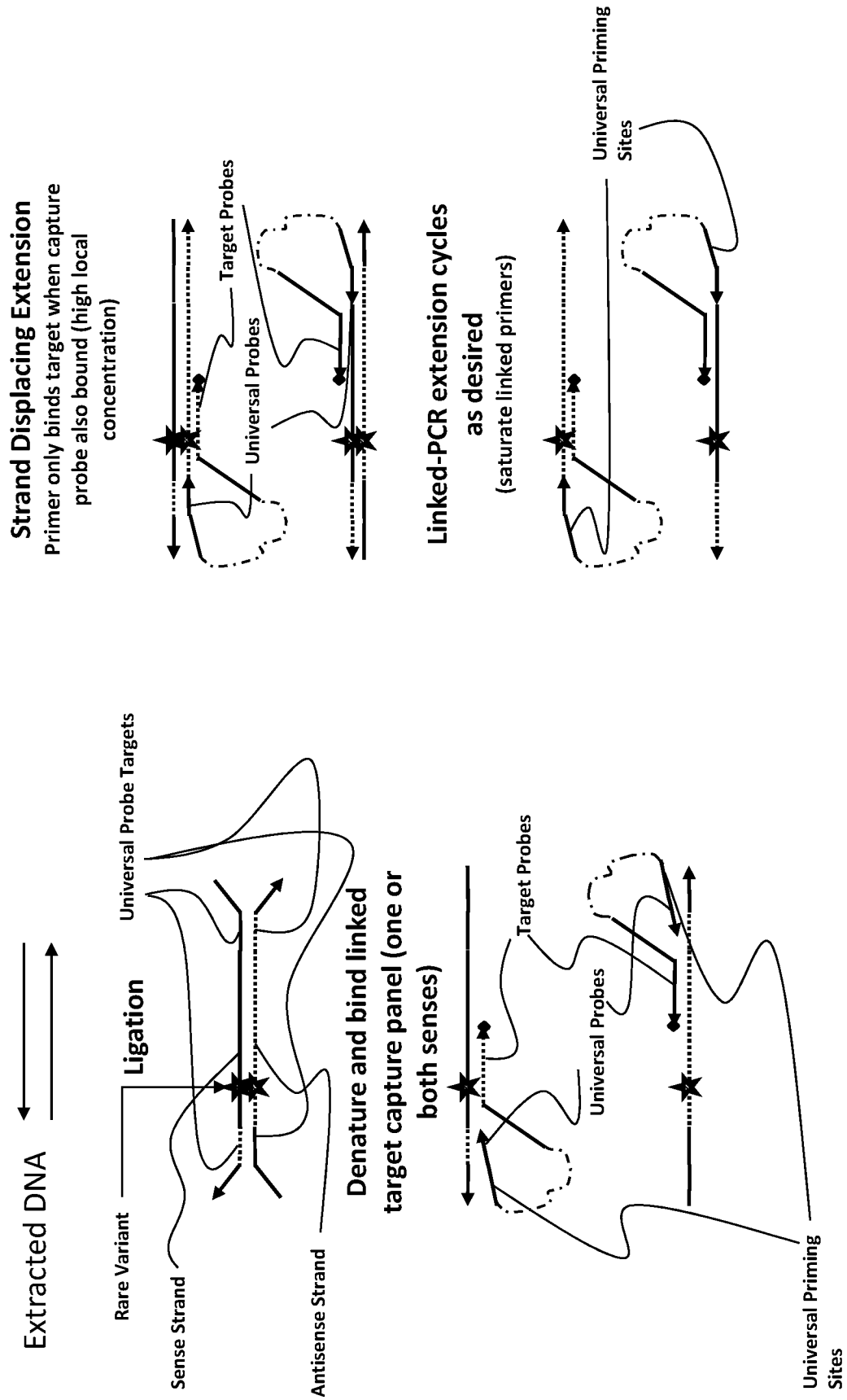

FIG. 34

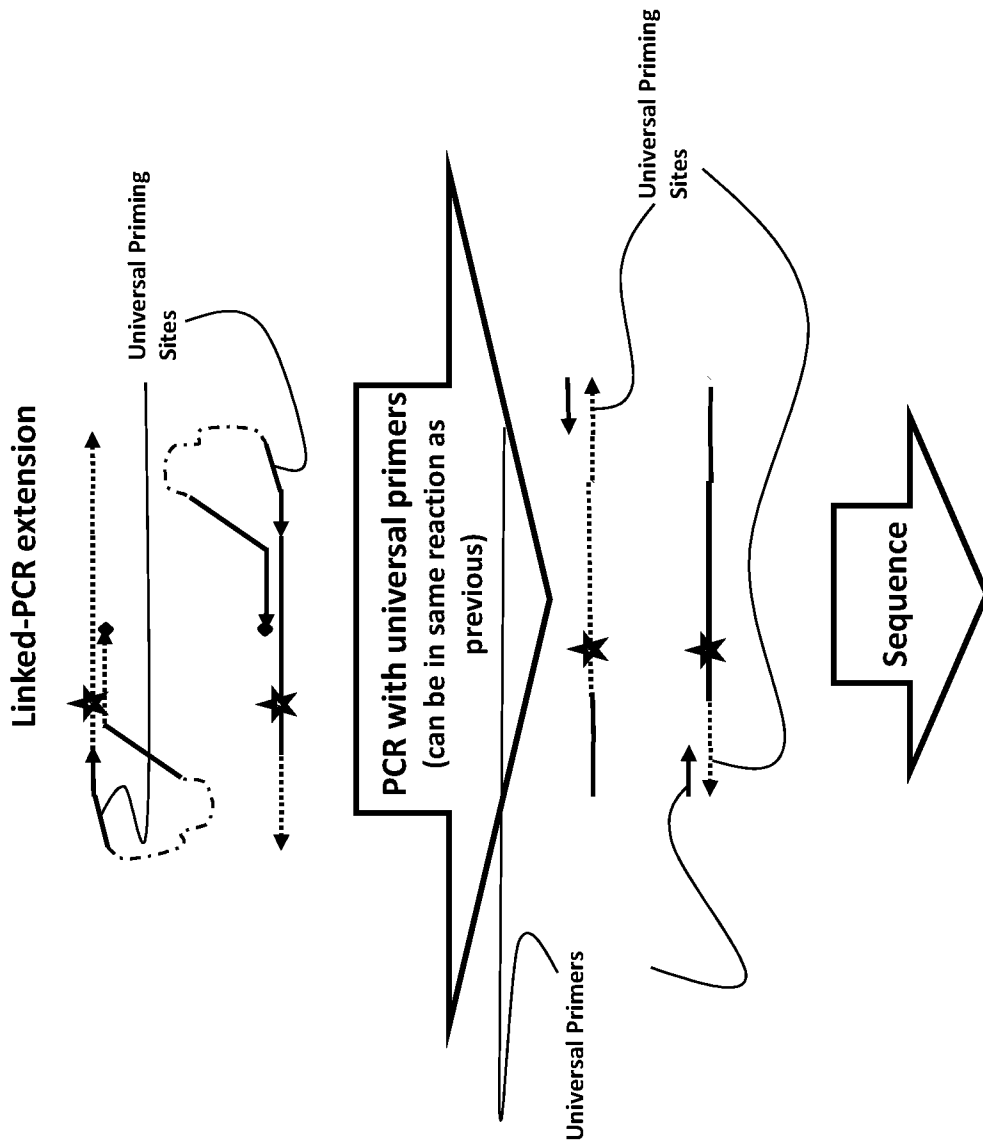

FIG. 35

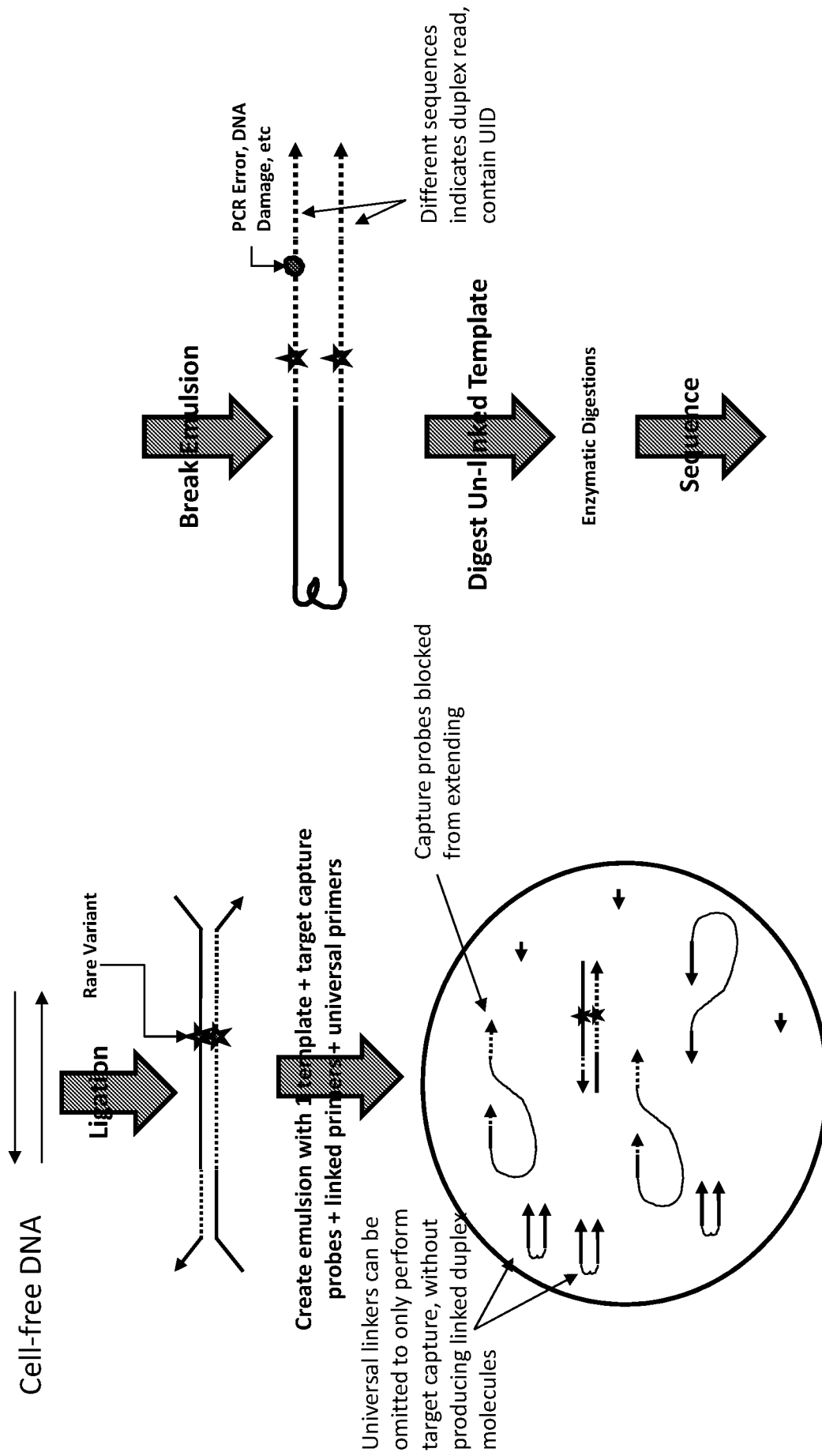
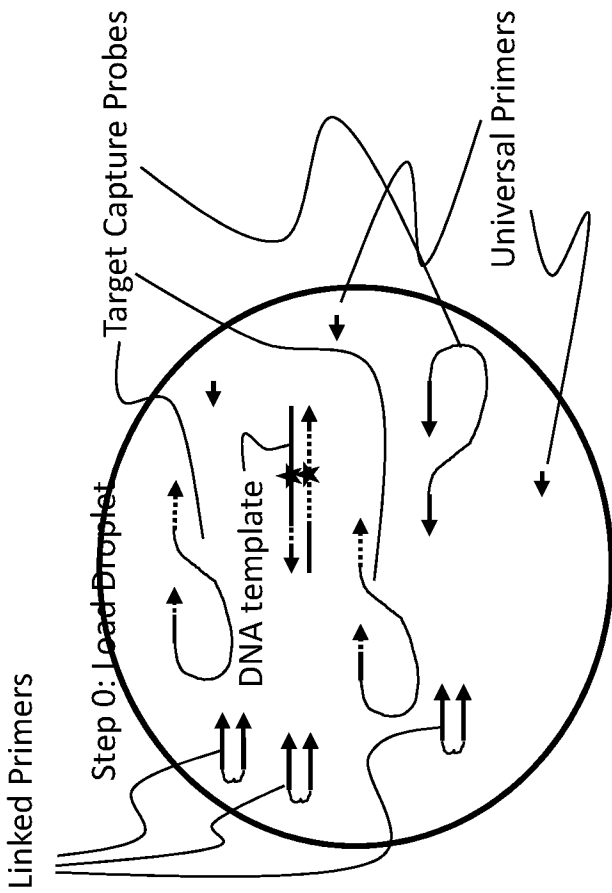
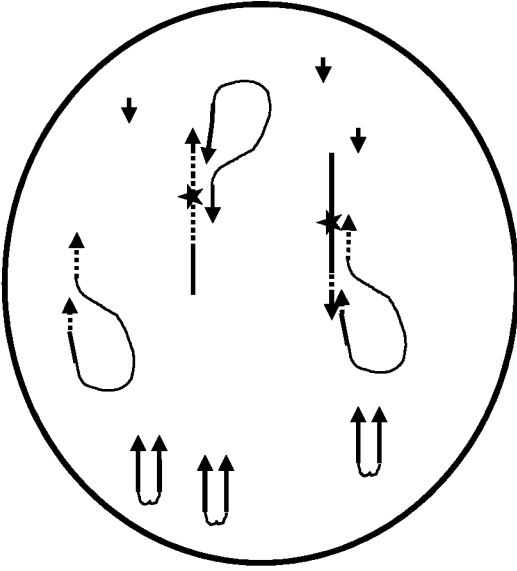

FIG. 36



Step 2: Universal primer binds only to captured targets



Step 1: Denature and Target Capture

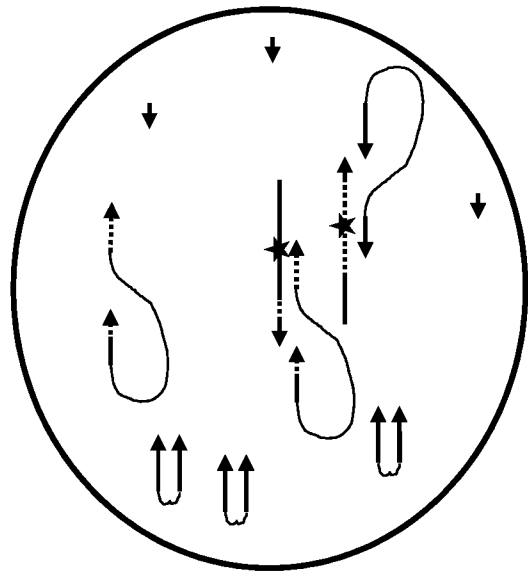

Step 3: Displacing extension of captured targets only

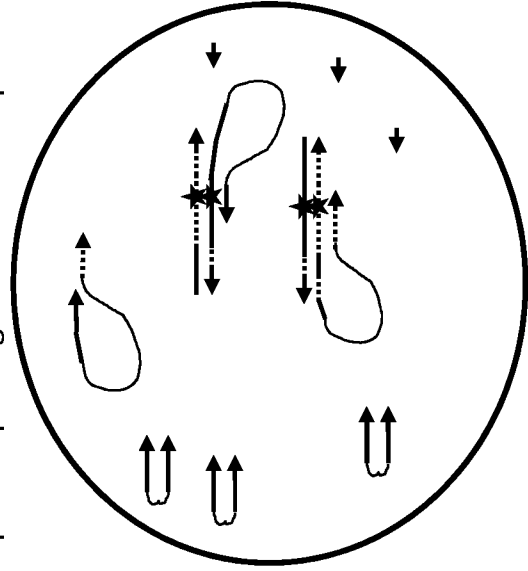
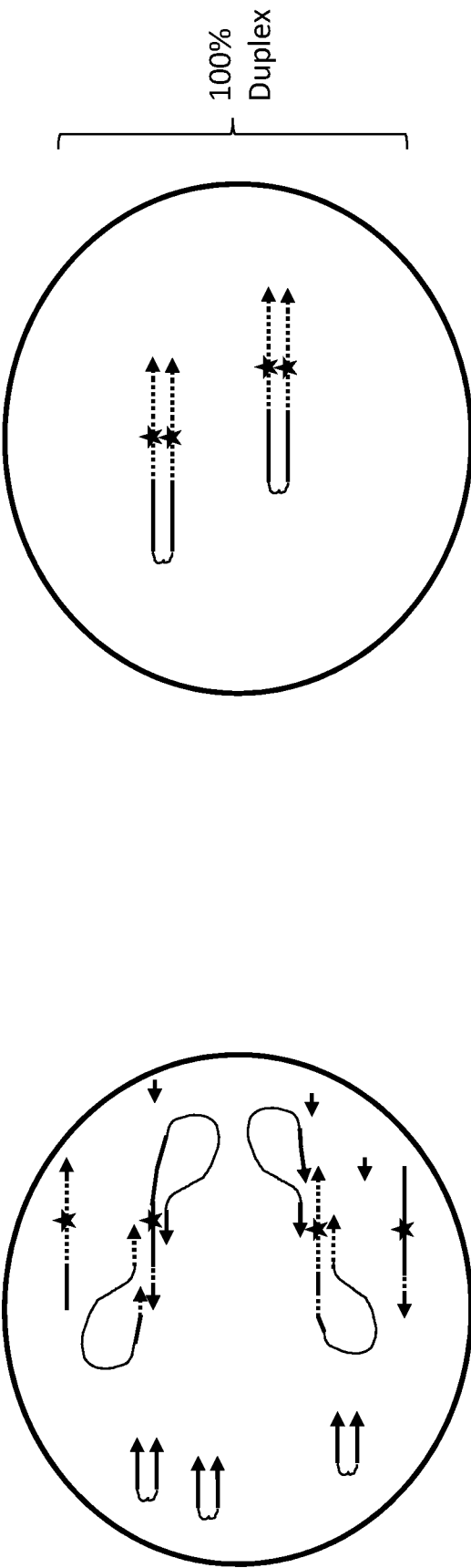

FIG. 37A

Step 4: Deplete Linked Target Primers (4-6 cycles, or more) Output: 100% linked products with duplex identification



Step 5: Priming with Universal Linked Primers

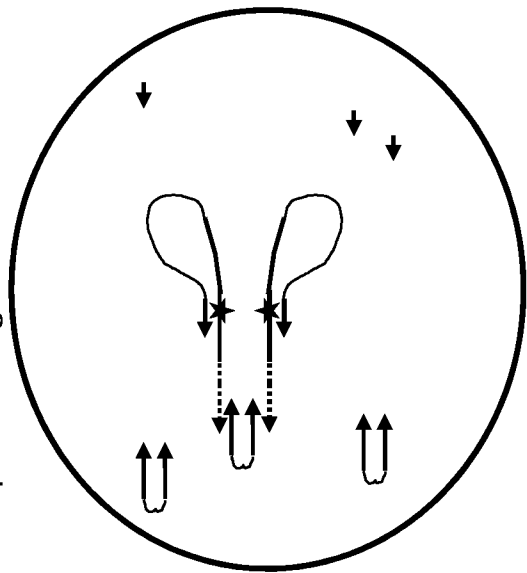

FIG. 37B

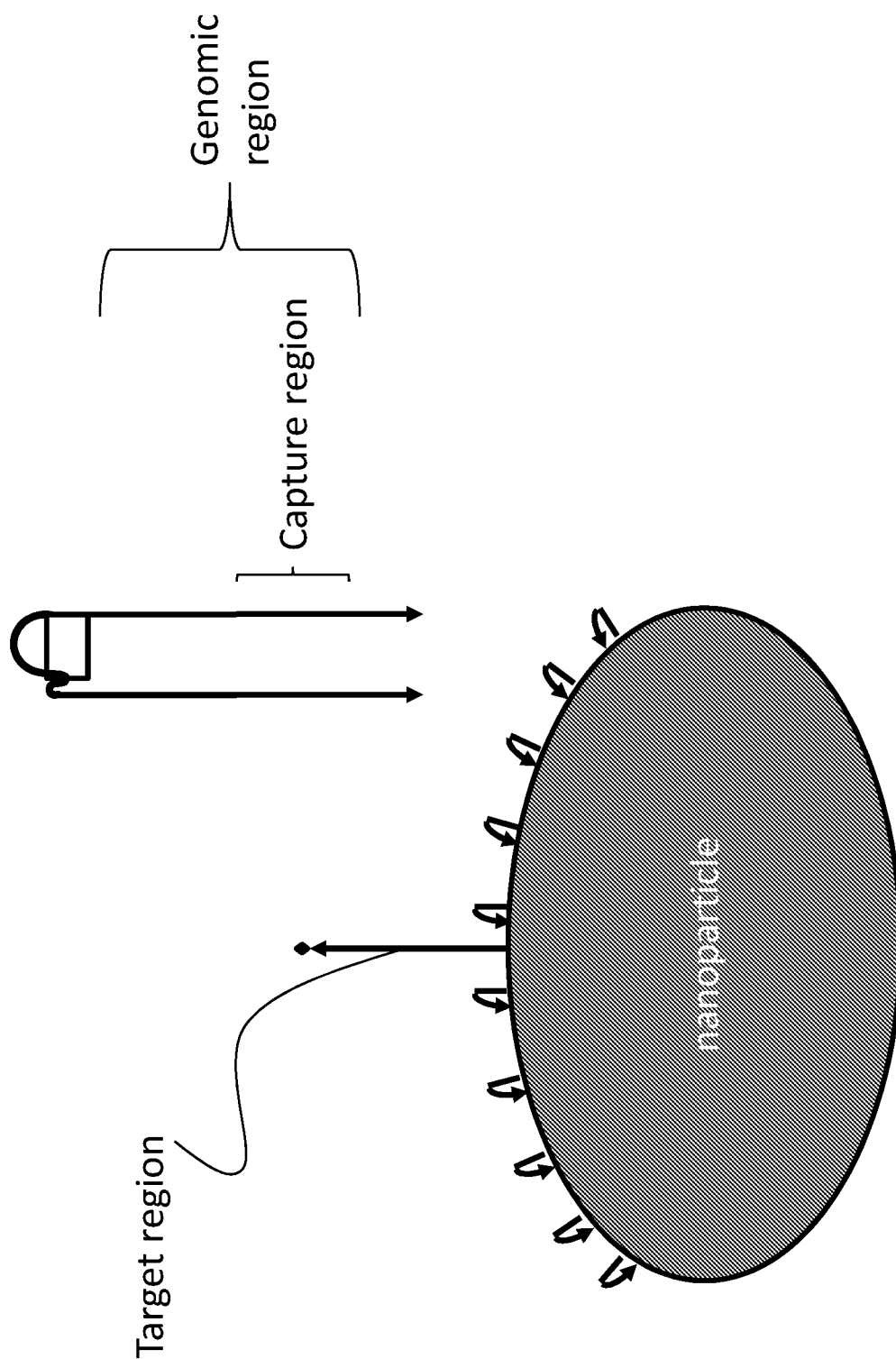

FIG. 38

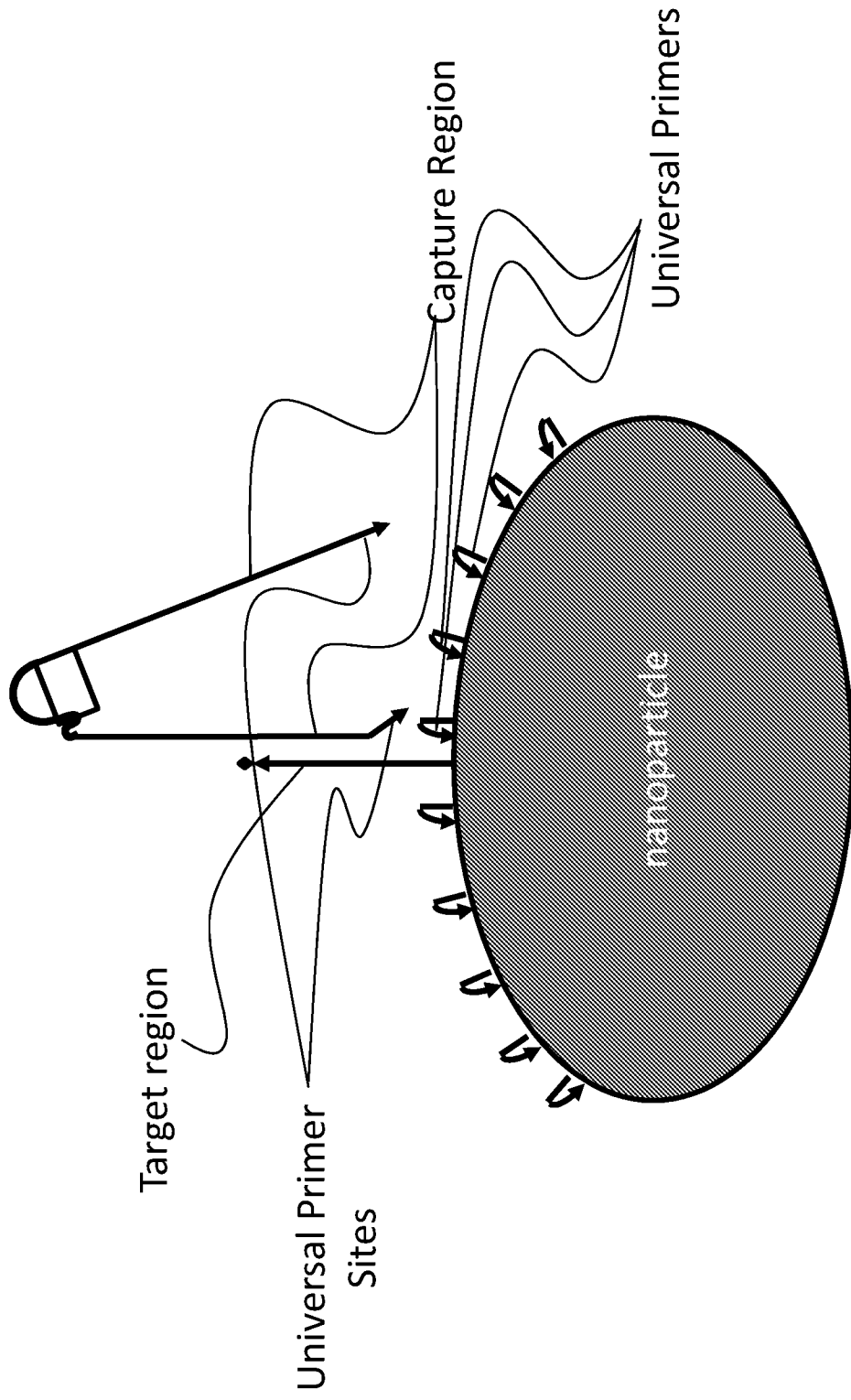

FIG. 39

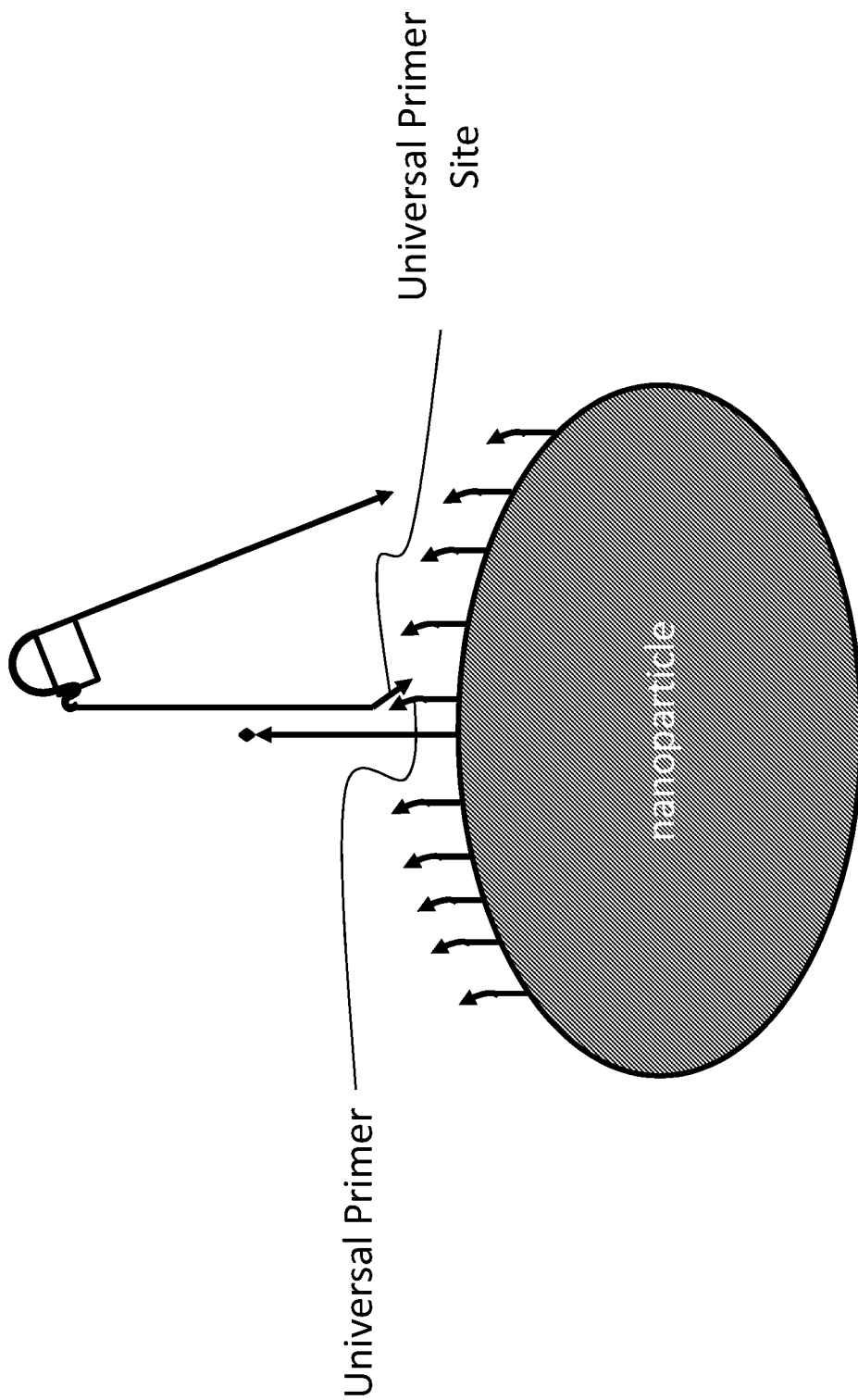

FIG. 40

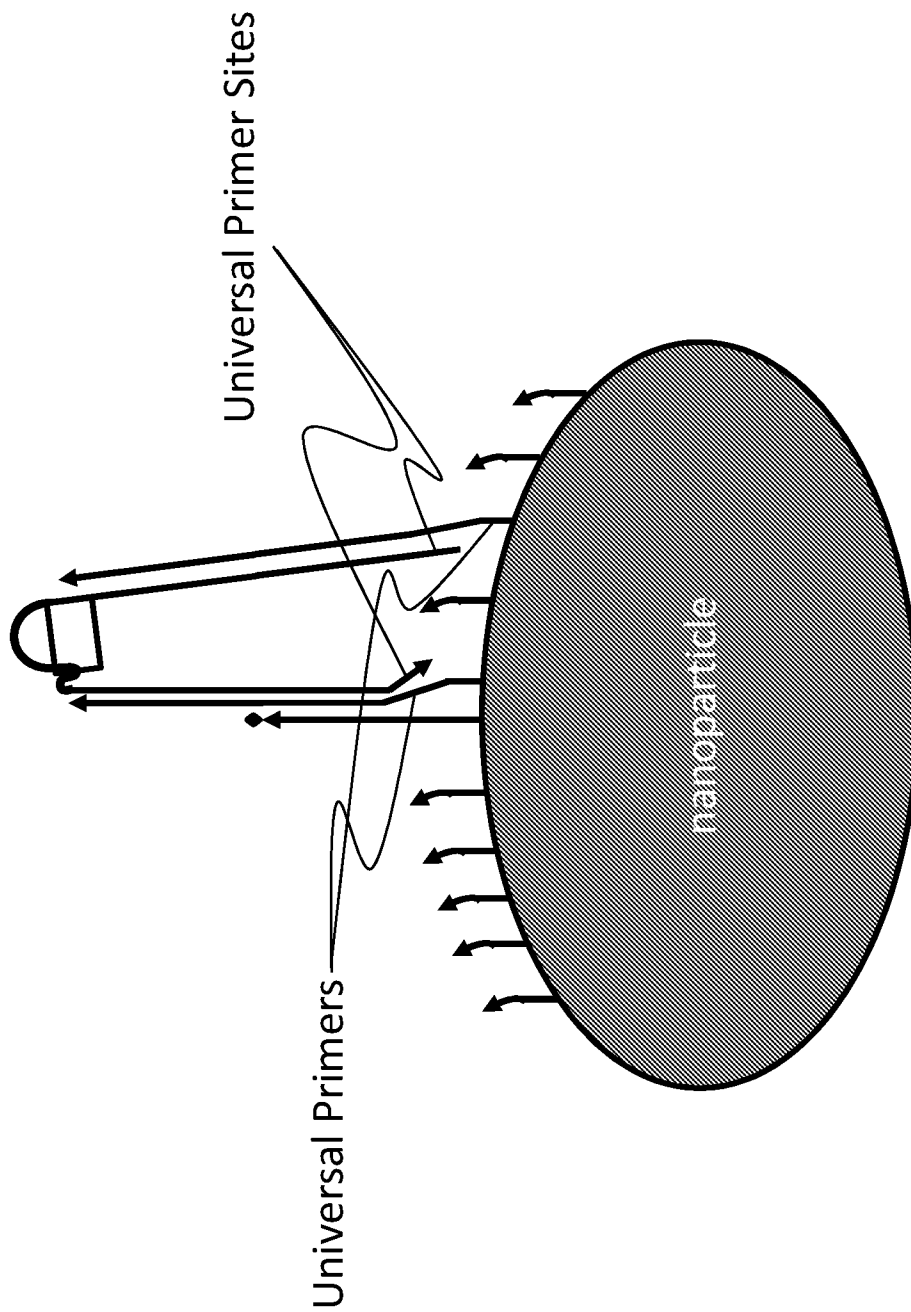

FIG. 41

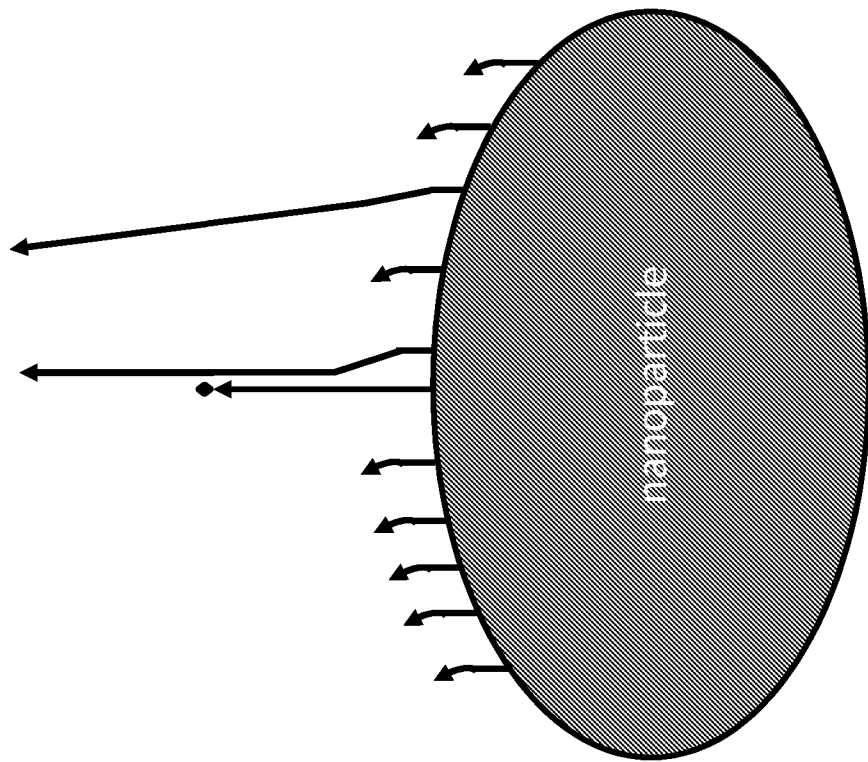

FIG. 42

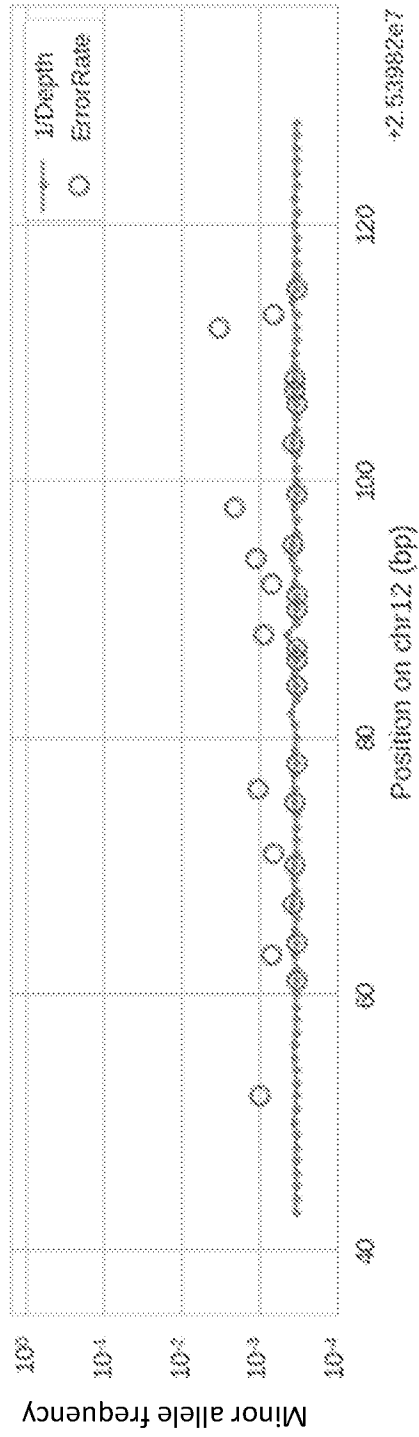

FIG. 43

INTERNATIONAL SEARCH REPORT

International application No.

PCT/IB2017/051778

A. CLASSIFICATION OF SUBJECT MATTER
 IPC: *C12Q 1/68* (2006.01), *C12N 15/10* (2006.01), *C40B 30/04* (2006.01), *C40B 40/06* (2006.01)

According to International Patent Classification (IPC) or to both national classification and IPC

B. FIELDS SEARCHED

Minimum documentation searched (classification system followed by classification symbols)
 IPC: ALL

Documentation searched other than minimum documentation to the extent that such documents are included in the fields searched

Electronic database(s) consulted during the international search (name of database(s) and, where practicable, search terms used)

Databases: Questel Orbit, CIPO Library Discovery Tool, Google Scholar

Keywords: link*, sequenc*, adapter, sense, antisense, duplex, library, prepar*, nucleic acid, flow cell, solid support, DNA, base call error

C. DOCUMENTS CONSIDERED TO BE RELEVANT

Category*	Citation of document, with indication, where appropriate, of the relevant passages	Relevant to claim No.
P,X	US 2016/0122814 A1 (DESPOTOVIC, M. et al.) 5 May 2016 (05-05-2016) *Entire Document*	1-16
A	WO 2013/126741 A1 (WATSON, A.) 29 August 2013 (29-08-2013)	
A	LOU, D.I. et al. "High-throughput DNA sequencing errors are reduced by orders of magnitude using circle sequencing", PNAS, 3 December 2013 (03-12-2013), Vol.110(49), pp. 19872-19877, doi:10.1073/pnas.1319590110	

Further documents are listed in the continuation of Box C.

See patent family annex.

* Special categories of cited documents:	"T" later document published after the international filing date or priority date and not in conflict with the application but cited to understand the principle or theory underlying the invention
"A" document defining the general state of the art which is not considered to be of particular relevance	"X" document of particular relevance; the claimed invention cannot be considered novel or cannot be considered to involve an inventive step when the document is taken alone
"E" earlier application or patent but published on or after the international filing date	"Y" document of particular relevance; the claimed invention cannot be considered to involve an inventive step when the document is combined with one or more other such documents, such combination being obvious to a person skilled in the art
"L" document which may throw doubts on priority claim(s) or which is cited to establish the publication date of another citation or other special reason (as specified)	"&" document member of the same patent family
"O" document referring to an oral disclosure, use, exhibition or other means	
"P" document published prior to the international filing date but later than the priority date claimed	

Date of the actual completion of the international search
 07 June 2017 (07-06-2017)

Date of mailing of the international search report
 23 June 2017 (23-06-2017)

Name and mailing address of the ISA/CA
 Canadian Intellectual Property Office
 Place du Portage I, C114 - 1st Floor, Box PCT
 50 Victoria Street
 Gatineau, Quebec K1A 0C9
 Facsimile No.: 819-953-2476

Authorized officer

Maria Mill (819) 639-6815

INTERNATIONAL SEARCH REPORT
Information on patent family members

International application No.
PCT/IB2017/051778

Patent Document Cited in Search Report	Publication Date	Patent Family Member(s)	Publication Date
US2016122814A1	05 May 2016 (05-05-2016)	None	
WO2013126741A1	29 August 2013 (29-08-2013)	EP2817418A1 EP2817418A4 US2013225418A1 US9176031B2	31 December 2014 (31-12-2014) 04 November 2015 (04-11-2015) 29 August 2013 (29-08-2013) 03 November 2015 (03-11-2015)