

E. BUSSEY.  
Cooking Stove.

No. 56,488.

Patented July 17, 1866.

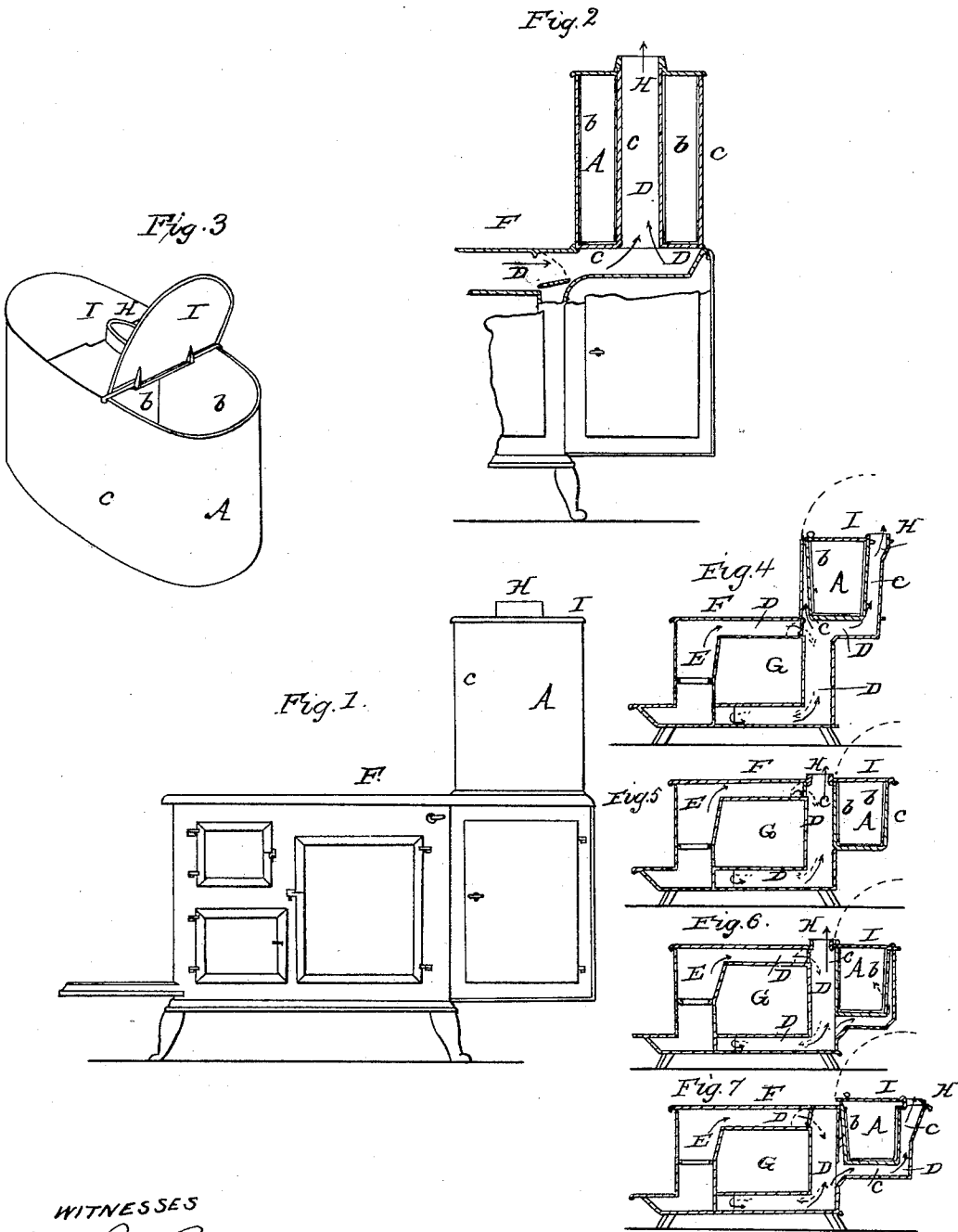

WITNESSES  
Chas W. Robinson  
H. J. M. L. Cool.

INVENTOR  
Ezek Bussey.

# UNITED STATES PATENT OFFICE.

ESEK BUSSEY, OF TROY, NEW YORK, ASSIGNOR TO HIMSELF AND CHAS. A. McLEOD, OF SAME PLACE.

## BOILER FOR COOKING-STOVES.

Specification forming part of Letters Patent No. 56,488, dated July 17, 1866.

*To all whom it may concern:*

Be it known that I, ESEK BUSSEY, of the city of Troy, in the county of Rensselaer and State of New York, have invented a new and useful Improvement in Cooking-Stoves, of which the following is a full and exact description, reference being had to the accompanying drawings, in which—

Figure 1 is a side elevation, Fig. 2 a partial central longitudinal sectional elevation, and Fig. 3 a perspective view, of a detached hot-water reservoir, all of a cooking-stove illustrative of my said invention; and Figs. 4, 5, 6, and 7 are central longitudinal sectional elevations of four other stoves illustrating my said improvement, similar parts being marked by like letters in all the figures, and the arrows therein being indicative of the courses in which the gases of combustion pass through the stove.

The nature of my invention consists in the employment of a water reservoir or tank constructed of cast-iron and covered upon its inner and outer surfaces by a composition of zinc and tin, or with zinc alone, in the manner and for the purposes substantially as herein described and set forth, and the combination of such water reservoir or tank with a cooking-stove, in the manner substantially as shown in the accompanying drawings.

It also consists in constructing a water reservoir or tank for cooking-stoves of cast-iron coated or covered upon its inner and outer surfaces by zinc, or an alloy of zinc and tin, in the manner substantially as herein described and set forth, so that the same shall neither rust upon the inside by reason of any use thereof, or become corroded upon the outer surface of the same by the action of any heat, vapors, or gases coming in direct contact with the same, in the manner substantially as herein described and set forth.

In carrying my said improvement into operation I alloy and coat the cast-iron body A, Figs. 3, 4, 5, 6, and 7, of the reservoir on its inner surface, *b*, and on its outer surface, *c*, with zinc, or an alloy of zinc, by any suitable means—for example, by first putting the same in dilute muriatic acid, and scouring the cast-iron body until its inner and outer surfaces are clean or free from scale, and then drying

and warming the so-cleaned cast-iron body, and next dipping, stirring, and rubbing it in a bath of melted zinc, or an alloy of zinc, with a flux of sal-ammoniac on top, until the inner and outer surfaces of the cast-iron water-reservoir body become thoroughly covered and coated with the zinc or alloy of zinc of the bath.

An alloy of zinc consisting of two thousand pounds of zinc and ten pounds of tin melted together I have found from experience forms a very good and cheap bath for use in covering and coating the inner and outer surfaces of the cast-iron body of said reservoir.

In carrying out my aforesaid improvement I shape and arrange a fire-flue or fire-flues, D, in respect to a fuel-chamber, E, a top cooking-plate, F, an oven, G, an exit-passage, H, and the water-reservoir A in any suitable manner, and so shape and arrange the said reservoir A that it shall form any suitable part of the casing of the said fire-flue or fire-flues, and that the flame or hot gases and vapors of combustion which shall circulate through the said fire-flue or fire-flues shall come in direct contact with the coated and alloyed outer surface, *c*, of the reservoir, either in any suitable part, as indicated by examples in Figs. 2, 5, and 7, or wholly, as illustrated in Figs. 4 and 6. In the aforesaid drawings, I is a hinged lid or cover on the open top of the reservoir A.

My aforesaid invention is of great practical utility in the following particulars, viz: First, by my said improvement a combination of a more durable water-reservoir with a cooking-stove is produced, which, while costing only a little more than if the reservoir were of cast-iron alone, and of equal weight, strength, and capacity, has the inner surface of the reservoir less liable to become rusty or dirty by the oxidizing action thereon of the water, steam, and air in the reservoir than if the reservoir were of cast-iron, and which has the metal of the reservoir less porous on its inner and outer surfaces, and much less liable to become corroded by the oxidizing action of the water, steam, or air in the reservoir and by the penetrating and corroding action of the hot acid vapors and gases of combustion which come in direct contact with the outer surface of the reservoir in the stove than if the reservoir were made of cast-iron alone; second, by my

aforesaid improvement a combined cooking-stove and hot-water reservoir is produced which, while costing less than if the reservoir were of copper, zinc, brass, or an alloy of zinc and tin, has a reservoir which is nearly or quite as free as one entirely constructed of zinc, brass, copper, or an alloy of zinc and tin would be from being oxidized or rusted on its inner surface by the water, steam, or air in the reservoir, or from being corroded on its outer surface by the chemical action of the flame or hot vapors or gases of combustion which come in direct contact with the outer surface of the reservoir in the stove, or from being melted by the intense heat of such flame or gases or vapors of combustion whenever the water shall become very low or entirely gone from within the reservoir; and, third, by my aforesaid invention I construct a cooking-stove having a permanent water-reservoir combined therewith, in which water is heated more directly, to a greater degree, as well as more economically, than would be the case in a cooking-stove having a reservoir composed of a body of cast-iron coated and alloyed on its inner and outer surfaces with zinc, or an alloy of zinc, and arranged or placed on the stove with a metal

plate or casing between the outer surface of the reservoir and the flame or hot gases of combustion in the stove, so that such flame or hot gases of combustion could not come in direct contact with the coated and alloyed outer surface of the water-reservoir.

What I claim as my invention, and desire to secure by Letters Patent, is—

1. A water-reservoir or water-tank constructed of cast-iron and entirely covered or coated upon the inner and outer surfaces thereof by zinc or an alloy of zinc, substantially as aforesaid, in combination with a cooking-stove, in the manner substantially as herein described and set forth.

2. The water reservoir or tank for cooking-stoves constructed entirely of cast-iron and then covered or coated upon the inner and outer surfaces with zinc, or an alloy of zinc and tin, in the manner and by the means and for the purposes substantially as herein described and set forth.

ESEK BUSSEY.

Witnesses:

CHAS. W. ROBINSON,  
H. S. McLEOD.