



- (51) International Patent Classification: **H01R 12/72** (2011.01)
- (21) International Application Number: PCT/CN2015/091180
- (22) International Filing Date: 30 September 2015 (30.09.2015)
- (25) Filing Language: English
- (26) Publication Language: English
- (71) Applicant: **HONEYWELL INTERNATIONAL INC.** [US/US]; 101 Columbia Road, Morristown, New Jersey 07962 (US).
- (71) Applicant (for US only): **LIU, Chaohong** [CN/CN]; RM 601, No. 14, LN 99, Wanding Road, Minhang District, Shanghai 201100 (CN).
- (72) Inventors; and
- (71) Applicants (for US only): **PENG, Wen** [CN/CN]; No. 430, Libing Road, Zhangjiang Hi-Tech Park, Pudong New Area, Shanghai 201203 (CN). **JIANG, Lei** [CN/CN]; No. 430, Libing Road, Zhangjiang Hi-Tech Park, Pudong New Area, Shanghai 201203 (CN).
- (74) Agent: **CHINA PATENT AGENT (H.K.) LTD.**; 22/F, Great Eagle Centre, 23 Harbour Road, Wanchai, Hong Kong Special Administrative Region (CN).
- (81) Designated States (unless otherwise indicated, for every kind of national protection available): AE, AG, AL, AM, AO, AT, AU, AZ, BA, BB, BG, BH, BN, BR, BW, BY, BZ, CA, CH, CL, CN, CO, CR, CU, CZ, DE, DK, DM, DO, DZ, EC, EE, EG, ES, FI, GB, GD, GE, GH, GM, GT, HN, HR, HU, ID, IL, IN, IR, IS, JP, KE, KG, KN, KP, KR, KZ, LA, LC, LK, LR, LS, LU, LY, MA, MD, ME, MG, MK, MN, MW, MX, MY, MZ, NA, NG, NI, NO, NZ, OM, PA, PE, PG, PH, PL, PT, QA, RO, RS, RU, RW, SA, SC, SD, SE, SG, SK, SL, SM, ST, SV, SY, TH, TJ, TM, TN, TR, TT, TZ, UA, UG, US, UZ, VC, VN, ZA, ZM, ZW.
- (84) Designated States (unless otherwise indicated, for every kind of regional protection available): ARIPO (BW, GH, GM, KE, LR, LS, MW, MZ, NA, RW, SD, SL, ST, SZ, TZ, UG, ZM, ZW), Eurasian (AM, AZ, BY, KG, KZ, RU, TJ, TM), European (AL, AT, BE, BG, CH, CY, CZ, DE, DK, EE, ES, FI, FR, GB, GR, HR, HU, IE, IS, IT, LT, LU, LV, MC, MK, MT, NL, NO, PL, PT, RO, RS, SE, SI, SK, SM, TR), OAPI (BF, BJ, CF, CG, CI, CM, GA, GN, GQ, GW, KM, ML, MR, NE, SN, TD, TG).

[Continued on next page]

(54) Title: GUIDE AND SUPPORT APPARATUS FOR PRINTED CIRCUIT BOARD

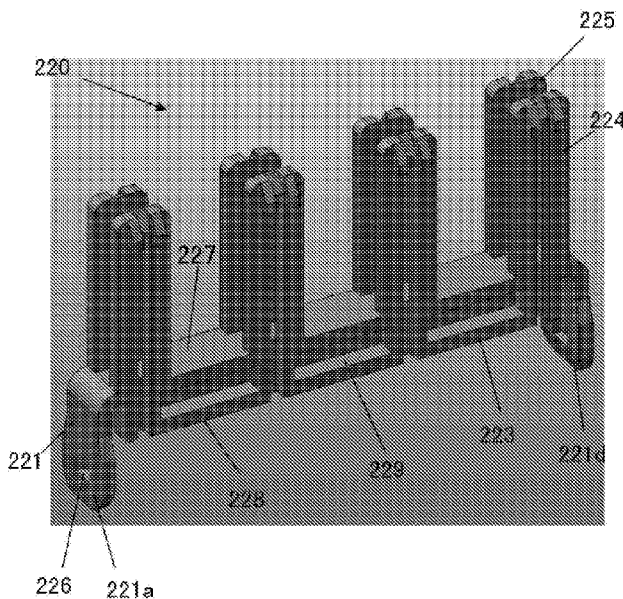

Fig. 2A

(57) Abstract: A guide and support apparatus(220, 420, 520, 620, 720, 820, 820a) is provided. The guide and support apparatus(220, 420, 520, 620, 720, 820, 820a) comprises: a mounting portion(221, 421, 721), a support portion(223, 423, 723) and a guide & lock portion(224, 225, 424, 425, 524, 525), wherein the support portion(223, 423, 723) extends to the guide & lock portion(224, 225, 424, 425, 524, 525) and is ended at the mounting portion(221, 421, 721); the mounting portion(221, 421, 721) extends downward from one or two ends of the support portion(223, 423, 723) and comprises a lock structure; and the guide & lock portion (224, 225, 424, 425, 524, 525) extends from the support portion(223, 423, 723) to a certain height. Further, a method for manufacturing the guide and support apparatus is provided.

WO 2017/054157 A1

Declarations under Rule 4.17:

— *as to applicant's entitlement to apply for and be granted a patent (Rule 4.17(ii))*

Published:

— *with international search report (Art. 21(3))*

Guide and Support Apparatus for Printed Circuit Board

TECHNICAL FIELD

Embodiments described herein generally relate to a support apparatus
5 for electronic device, and more particularly, to a guide and support
apparatus for printed circuit board.

BACKGROUND

In electronic devices, a printed circuit board is usually employed to
10 carry various electronic components for carrying out several functions.
The component density now is becoming higher and higher in order to
achieve more functions with less space. This requires the mechanical
structure to be compact and efficient. To this end, the different portions of
the printed circuit board are modularized and connected together
15 perpendicularly.

Figure 1A and 1B show an assembled printed circuit board in the
prior art. Several child boards 1 are held on the mother board 7 by guide
rails 2 and 3. As shown in figure 1A and 1B, the guide rails 2 are placed
perpendicularly to front side of the mother board 7 and fixed by screws 5
20 on the opposed back side of the mother board 7. The guide rails 3 are
mounted perpendicularly on the mother board 7 with its lock head 6
passing through the holes of the mother board 7 to the back side and the
lock wings 4 against the front side. The child boards 1 are supported and
locked between two guide rails 2, two guide rails 3 or one guide rails 2 and
25 one guild rail 3. In this way, it is easy for the child board 1 to be mounted
on the mother board 7 and occupy less space.

However, in the case where the mother board carries many child
boards and has a lot of electronic components to be mounted thereon, the
existing guide and support structure cannot meet the high density
30 requirement.

Therefore, there is a need for an improved guide and support
apparatus which saves more space and is easy to use.

SUMMARY

In one embodiment, a guide and support apparatus is provided. The guide and support apparatus comprise: a mounting portion, a support
5 portion and a guide & lock portion, wherein the support portion extending perpendicularly to the guide & lock portion and ended at the mounting portion; the mounting portion extends downward from one or two ends of the support portion and comprises a lock structure; and the guide & lock portion extends from the support portion vertically to a certain height.

10 In another embodiment, a further guide and support apparatus is provided. The guide and support apparatus comprise: a support portion and a guide & lock portion, the guide & lock portion extends from the support portion vertically to a certain height, wherein the guide & lock portion includes first and second guide & lock portions. The guide & lock portion
15 comprises two ribs which extend up to a certain height from the support portion and connected by a lock portion on their top end. A slot extends between the two ribs and ends with the lock portion. The lock portion is positioned between the two ribs, and has a top surface and a front surface. Two projections are formed next to the lock portion such that a groove is
20 defined by the front surface of the lock portion and the two projections. The top surface of the lock portion is inclined relative to the front side of the ribs.

In another embodiment, a board matrix is provided. The board matrix comprises a child board, a mother board, and the guide and support
25 apparatus according to above embodiment.

In another embodiment, A method for manufacturing a guide and support apparatus is provided. The method comprises forming a support
portion; forming a guide & lock portion which extends from the support portion to a certain height; and forming a mounting portion. The support
30 portion extending perpendicularly to the guide & lock portion and ended at the mounting portion. The mounting portion extends downward from one

or two ends of the support portion and comprises a lock structure. The lock structure is below the support portion.

DRAWINGS

5 Understanding that the drawings depict only exemplary embodiments and are not therefore to be considered limiting in scope, the exemplary embodiments will be described with additional specificity and detail through the use of the accompanying drawings, in which:

10 Figure 1A and 1B show an assembled printed circuit board in accordance with the prior art;

 Figure 2A shows an example embodiment of a guide and support apparatus according to the disclosure;

 Figure 2B shows another embodiment of a guide and support apparatus according to the disclosure;

15 Figure 3 shows the enlarged drawing of the guide & lock portion in figure 2A and 2B, according to the disclosure;

 Figure 4 shows an example process for mounting the guide and support apparatus onto the mother board 40 which is a printed circuit board, according to the disclosure.

20 Figure 5A shows an example process for mounting the child board 51 into the guide and support apparatus 20 according to the disclosure;

 Figure 5B shows a perspective diagram of the assembled board matrix according to the disclosure;

25 Figure 6 shows a perspective diagram of another board matrix according to the disclosure;

 Figure 7A shows a perspective diagram of the assembled board matrix viewed from the front side according to the disclosure;

 Figure 7B shows another perspective diagram of the assembled board matrix viewed from the back side according to the disclosure.

30 Figure 8A and 8B show another embodiment of the board matrix for the child boards with different width according to the disclosure; and

Figure 9 is a photo of the board matrix in a completed product according to the disclosure.

In accordance with common practice, the various described features are not drawn to scale but are drawn to emphasize specific features
5 relevant to the exemplary embodiments.

DETAILED DESCRIPTION

In the following detailed description, reference is made to the accompanying drawings that form a part hereof, and in which is shown by
10 way of illustration specific illustrative embodiments. However, it is to be understood that other embodiments may be utilized and that logical, mechanical, and electrical changes may be made. Furthermore, the method presented in the drawing figures and the specification is not to be construed as limiting the order in which the individual steps may be
15 performed. The following detailed description is, therefore, not to be taken in a limiting sense.

As used herein, the terms “having”, “containing”, “including”, “comprising” and the like are open ended terms that indicate the presence of stated elements or features but do not preclude additional elements or
20 features. The articles “a”, “an” and “the” are intended to include the plural as well as the singular, unless the context clearly indicates otherwise.

Figure 2A shows an example embodiment of a guide and support apparatus 220 according to the disclosure. The guide and support apparatus 220 includes a mounting portion 221, a support portion 223 and a guide &
25 lock portion 224, 225. The support portion 223 extends perpendicularly to the guide & lock portion 224, 225 and is ended with the mounting portion 221. The support portion 223 includes top surface 227 and bottom surface 228 (not shown).

The mounting portions 221 extend downward from one or two ends
30 where the support portion 223 is ended. The mounting portions 221 may be angled relative to the top surface 227 and bottom surface 228, and preferably, perpendicular to the top surface 227 and bottom surface 228.

The mounting portion 221 includes a foot 221a, and a hole 226 is formed in the foot 221a. The level of the hole 226 is below the bottom surface of the support portion 223, i.e. the peak in hole 226 is below the bottom surface of the support portion 223, such that there is a space formed
5 between the support portion 223 and an upper side of a mother board, i.e. the support portion 223 does not contact the mother board, when the guide and support apparatus 220 is mounted on the mother board. The mounting portion 221 can be flat and the holes 226 formed in foot 221a of the mounting portions 221 extending from the different end of the support
10 portion 223 face to each other, and preferably, aligned with each other. The inner side at the bottom of the foot 221a can be cutoff partly to form a slope face 221d. The hole 226 can be shaped as rectangle, square, circle, ellipse, triangle, or any other suitable shape. The person skilled in the art should realize from above description that two or more holes which are
15 located at the same level or different level can be formed in one foot, although only one hole 226 is shown in each foot.

There are several concaves 229 on the front side and the back side of the support portion 223 to strengthen the support portion 223 and to reduce the weight of the structure.

20 The guide &lock portion includes one or more first guide &lock portion 224 and one or more second guide &lock portion 225, for example, preferably, four first guide &lock portion 224 and four second guide &lock portion 225 in this embodiment, which all extend from the bottom surface 228 through the top surface 227 up to a certain height. As seen in figure
25 2A, the first guide &lock portion 224 is located on the front side and second guide &lock portion 225 is located on the back side of the support portion 223. The two kinds of guide &lock portion 224 and 225 are back to back, parallel and aligned with each other. The inner sides at the bottom of the foot 221a can be cut off partly to form a slope face 221d. There are
30 guide and lock structure facing outward on the guide &lock portion, as described below. The concaves 229 are formed between two adjacent guide &lock portions along each side of the support portion 223.

The mounting portion 221, the support portion 223 and the guide & lock portion 224, 225 may be separate parts which can be assembled together by screw, pressing fit or snapping fit, or they can be integral. Some or all of the mounting portion 221, the support portion 223 and the
5 guide & lock portion 224, 225 can be manufactured by injection molding, machining, bending or any other manufacturing process that can form the structure from any suitable material, such as plastic, sheet metal, and so on.

Figure 2B shows another embodiment of a guide and support
10 apparatus 220 according to the disclosure. As seen in figure 2B, the guide and support apparatus 220 includes a mounting portion 222, a support portion 223 and a guide & lock portion 224, 225. The support portion 223 extends perpendicularly to the guide & lock portion 224, 225 and is ended with the mounting portion 222. The support portion 223 includes top
15 surface 227 and bottom surface 228 (not shown).

The mounting portions 222 extend downward from one or two ends where the support portion 223 is ended. The mounting portions 222 may be angled relative to the top surface 227 and bottom surface 228, and preferably, perpendicular to the top surface 227 and bottom surface 228.
20 The mounting portion 222 includes two feet 222a and 222b which are separated by a slot 222c. A hole 226 is formed in each of the feet 222a and 222b. As shown in figure 2B, the holes 226 formed in different feet are located at the same level which are below the bottom surface of the support portion 223 such that there is a space formed between the support
25 portion 223 and a upper side of a mother board when the guide and support apparatus 220 is mounted onto the mother board. The mounting portion 222 can be flat and the holes 226 formed in foot 222a and 222b of the mounting portions 222 extending from the different end of the support portion 223 face to each other, and preferably, aligned with each other.
30 The hole 226 can be shaped as rectangle, square, circle, ellipse, triangle, or any other suitable shape. The person skilled in the art should realize from above description that two or more holes which are located at the same

level or different level can be formed in one foot, although only one hole 226 is shown in each foot.

There are several concaves 229 on the front side and the back side of the support portion 223 to strengthen the support portion 223 and to reduce the weight of the structure.

The guide & lock portion includes one or more first guide & lock portion 224 and one or more second guide & lock portion 225, for example, preferably, four first guide & lock portion 224 and three second guide & lock portion 225 in this embodiment, which all extend from the bottom surface 228 through the top surface 227 up to a certain height. As seen in figure 2B, the first guide & lock portion 224 is located on the front side and second guide & lock portion 225 is located on the back side of the support portion 223. The two kinds of guide & lock portion 224 and 225 are arranged to be back to back, parallel, and interleaved but not aligned with each other. There are guide and lock structure facing outward on the guide & lock portion 224 and 225, as described below. The concaves 229 are formed between two adjacent guide & lock portions along each side of the support portion 223, or between the guide & lock portion and the end of the support portion 223.

Similarly to the structure in figure 2A, the mounting portion 222, the support portion 223 and the guide & lock portion 224, 225 in figure 2B may be discrete components which can be assembled together, or they can be integral. Some or all of the mounting portion 222, the support portion 223 and the guide & lock portion 224, 225 can be manufactured by injection molding, machining, bending or any other manufacturing process that can form the structure from any suitable material, such as plastic, sheet metal, and so on.

Figure 3 shows the enlarged drawing of the guide & lock portion 224 and 225 in figure 2A and 2B, according to the disclosure. As shown in figure 3, the guide & lock portion comprises two ribs 331 which extend up to a certain height from the top surface of the support portion 223 and connected by a lock portion 335 on their top end. The two ribs 331 may be

parallel to each other and a slot 332 is formed between them. The slot 332 extends downward to the bottom surface of the support portion and upward to the lock portion 335.

The lock portion 335 is positioned between the two ribs 331 and has a top surface 335a and a front surface 335b. The top surface 335a may be inclined relative to the front side 331a of ribs 331 such that a child board can be guided into the slot 332 via the inclined top surface 335a and locked easily. In one embodiment, the top surface 335b may flush with the front side 331a of rib 331. In another embodiment, the top surface 335b may be parallel to and lower than the front side 331a of rib 331 such that the child board is limited in the slot 332 when it is assembled.

A projection 334 is formed on the top of each rib 331. As shown in figure 3, the projection 334 is located on the front side 331a and next to the lock portion 335. The projection 334 has a top surface 334a and a front surface 334b. The top surface 334a may be inclined relative to the front side 331a of ribs 331 and the top surface 334b may be parallel to the front side 331a of rib 331. The projections 334 on each rib 331 are paired. A groove 333 is defined by the lock portion 335 and a pair of projections 334 which is used to guide the child board. The guide and lock structure is constituted of the lock portion 335, the projection 334, the groove 333 and the slot 332.

The person skilled in the art should realize that two or more lock portion 335 can be formed between the two ribs and two or more pairs of projections 334 can be formed on the front side 331a of the rib 331, although only one lock portion 335 and one pair of projections 334 are shown. Further, in one embodiment, in the case that the top surface 335b of lock portion 335 may be lower than the front side 331a of rib 331, the pair of projections 334 is not necessary. The person skilled in the art should realize that other structures which can achieve the similar function to the guide & lock portion in figure 3, existing or developed later, can be used.

Figure 4 shows an example process for mounting the guide and support apparatus 420 onto the mother board 440 which is a printed circuit board, according to the disclosure. As shown in figure 4, several slots 441 are formed at both right and left edges of the mother board 440 by cutting
5 off some material from the mother board. The size of the slot 441 corresponds to that of the foot 421a of the mounting portion 421. A convex 442 is formed in each slot 441, preferably, in the middle of the slot 441. The size of the convex 442 is matched with that of the hole 426 in foot 421a of the mounting portion 421. The slots 441 and convexes 442 at both
10 edges of the mother board 440 may be formed symmetrically.

In order to mount the guide and support apparatus 420 onto the mother board 440, firstly, the guide and support apparatus 420 is located to make the guide & lock portions 424, 425 perpendicular to the mother board 440 and the mounting portion 421 aligned with the slot 441
15 substantially. Then, the guide and support apparatus 420 is moved toward the mother board 440 until the foot 421a of the mounting portion 421 contacts the convex 442 on the slot 441. After that, the mounting portion 421 will be deformed outward elastically, for example, by a force applied onto slope face 421d.

Next, the guide and support apparatus 420 continues to move toward
20 the mother board until the convexes 442 are inserted into the holes 426 of the mounting portion 421. As such, the guide and support apparatus 420 is mounted and locked onto the mother board 440 vertically. The others guide and support apparatus 420 can be mounted onto the mother board 40
25 in a similar way.

In this way, the guide and support apparatus 420 is mounted on mother board 440 without use of screws 5 and the lock head 6 on the back side, as depicted in figure 1A and 1B. Further, there are spaces formed between the bottom surface 428 of the support portion 423 and the upper
30 side 443 of the mother board 440 because the level of the hole 426 is below the bottom surface of the support portion 423, as described in figure 2A. Therefore, the upper side and the back side both are not occupied by

the guide and support apparatus 420. Thus, the upper side and the back side can be used to carry more electronic component on the mother board, as depicted in figure 7A and 7B.

In another embodiment, alternatively, instead of slot 441 and convex 5 442 both formed at the both edges of mother board, only convex 442 projects from the both edges. The size of the convex 442 is matched with that of the hole 426 in foot 221a of the mounting portion 421 and convexes 442 at both edges of the mother board 440 may be formed symmetrically.

Although the convex 442 and the hole 426 is used to lock and support 10 the guide and support apparatus 420, the person skilled in the art should realize that some other locking and supporting structure can be used, as long as they can realize the similar effect.

Figure 5A shows an example process for mounting the child board 551 into the guide and support apparatus 520 according to the disclosure. 15 Three guide and support apparatuses 520 are mounted onto the motherboard 540 vertically. They are spaced apart by a distance and their respective guide and lock structures are faced and aligned. As shown in figure 5A, a child board 550 is located above the mother board 540 and aligned with the space between two adjacent guide and support apparatuses 20 520. Two board slots 551 may be formed at left and right edges of the child board 550 to be locked with the lock portion 335, as shown in figure 3. The lower left corner and right corners of the child board 550 may be cut off to form respective slope structures 552 which match the top surface 335a of the lock portion 335, also as shown in figure 3.

When mounting the child board 550, firstly, the child board 550 is 25 moved downward such that the slope structure 552 contacts the top surface 335a of the lock portion 335. Then, the board is pushed to make the guide & lock portions 524 and 525 deformed outward to allow the child board to come into the groove 333, as depicted in figure 3. the child board 550 30 keeps moving downward until the lock portion 335 comes into the board slot 551 where the board edge of the child board 550 snap into the slot 332 and the child board 550 is locked by the guide & support portions 524 and

525. The others child board 550 can be mounted onto the guide & lock portions 524 and 525 in a similar way. A board matrix may be formed which includes a mother board 540, one or more guide and support apparatuses 520 and a plurality of child boards 550 when all the child boards 550 are mounted in place.

Figure 5B shows a perspective diagram of the assembled board matrix according to the disclosure. As shown in figure 5B, three guide and support apparatuses 520 are mounted on the mother board 540, each guide and support apparatuses 520 including four first guide & support portions 524 and four first guide & support portions 525. In that case, eight child boards 550 can be mounted on one mother board 540. As seen from figures, all the guide and support apparatuses 520 and child boards 550 can be assembled easily, thus a compact and flexible design for board matrix is achieved.

Figure 6 shows a perspective diagram of another board matrix according to the disclosure. As shown in figure 6, two covers 660 which are parallel to the guide and support apparatus 620 are provided at the edge of mother board 660. Several trenches 661 are formed by cutting off some material from the cover 660. When mounted to the edge of the mother board 640, the trenches 661 are parallel to and aligned with the slot 332 on the guide & lock portion 224, as shown in figure 3. The child board 650 can be inserted between the guide and support apparatus 620 and the cover 660, and is locked by trench 661. By use of the cover 660, more child boards 650 can be mounted onto the mother board 640. Thus an even higher density design for electronic devices is archived. The cover 660 can be made of plastic, sheet metal or any suitable material.

Figure 7A shows a perspective diagram of the assembled board matrix viewed from the front side according to the disclosure. As seen from figure 7A, there is a space 771 formed between the support portion 723 of the guide and support apparatus 720 and an upper side 743 of a mother board 740 because the level of the hole 726 in mounting portion 721 is below the bottom surface of the support portion 723. A plurality of

electronic components 772 can be mounted just under the guide and support apparatus.

Figure 7B shows another perspective diagram of the assembled board matrix viewed from the back side according to the disclosure. As seen from figure 7B, the guide and support apparatus 720 is mounted onto the mother board 740 via mounting portion 721 at the both edges of the mother board 740 without use of screws 5 and the lock heads 6 (as depicted in figure 1) on the back side of the mother board 740. In other words, the back side of the mother board 740 is not occupied by any lock elements. Therefore, the space on the back side is also available for electronic components, for example, a relative big display screen. By this way, the mother board 740 can carry many child boards and have a lot of electronic components to be mounted thereon.

As seen from figures 5-7, all the child boards mounted between two adjacent guide and support apparatuses must have the same width. However, in some case, multiple child boards with different width need to be mounted between two adjacent guide and support apparatuses. The solutions in figures 5-7 can not meet this requirement.

Figure 8A and 8B show another embodiment of the board matrix for the child boards with different width according to the disclosure. Figure 8A is a perspective diagram of the assembled board matrix, and figure 8B is a top view of the assembled board matrix. As shown, the child boards 850 and 850a are different in width. Accordingly, the guide and support apparatuses 820 and 820a may be of different length. The length of the guide and support apparatuses 820 and 820a can be adjusted according to the number of the child board 850 and 850a. Mounting holes 881 are formed between the left and right edges of the mother board 840 by cutting off some materials from the mother board 840. Several convexes 882 (not shown) are formed in the mounting holes 881 similarly to the convex 442 as depicted in figure 4. The mounting hole 881 and convex 882 between the left and right edges aligned with the slots 841 or convexes 842 at the both edges of the mother board 840. In this way, the guide and support

apparatuses 820 with different length can be mounted via any two aligned convexes, for example, via two convexes 842 at the left and right edges of the mother board 840, via one convex 842 at one edge and one convex 882 between the two edges, and via two convex 882 between the two edges.

5 As shown in 8A, there is also a space formed between the guide and support apparatuses 820 with different length and the upper side of a mother board 840 when the different guide and support apparatus 820 is mounted on the mother board 840, such that the electronic components 872 can be mounted just under the guide and support apparatuses 820 with
10 different length.

Figure 9 is a photo of the board matrix in a completed product according to the disclosure. As shown in figure 9, several child boards are mounted onto the mother board via the guide and support apparatus. The guide and support apparatus takes little on board space on both side of the
15 print circuit board or the mother board, and it is easy to build up a board matrix via the compact and flexible design of the guide & lock portion.

EXAMPLE EMBODIMENTS

Example 1 includes a guide and support apparatus comprising: a
20 mounting portion, a support portion and a guide & lock portion, wherein the support portion extending perpendicularly to the guide & lock portion and ended at the mounting portion; the mounting portion extends downward from one or two ends of the support portion and comprises a lock structure; the guide & lock portion extends from the support portion
25 vertically to a certain height.

Example 2 includes the guide and support apparatus according to example 1, wherein lock structure is below the support portion.

Example 3 includes the guide and support apparatus according to example 1 or 2, wherein the support portion comprises a top surface and a
30 bottom surface, the lock structure is a hole formed in the support portion, and the peak in the hole is below the bottom surface.

Example 4 includes the guide and support apparatus according to any one of examples 1-3, wherein the guide & lock portion is arranged to guide a child board, and the mounting portion can be mounted to a mother board via the lock structure such that the guide and support apparatus is mounted
5 to the mother board.

Example 5 includes the guide and support apparatus according to example 4, wherein the mother board and the child board are printed circuit board.

Example 6 includes the guide and support apparatus according to any
10 one of examples 1-5, wherein when the guide and support apparatus is mounted to a mother board via the mounting portion, a space can be formed between the support portion and the mother board.

Example 7 includes the guide and support apparatus according to example 6, the space is between the bottom surface of support portion and
15 the upper side of the mother board.

Example 8 includes the guide and support apparatus according to any one of examples 1-7, wherein the guide & lock portion includes first and second guide & lock portions, which all extend from the support portion up to a certain height, the first guide & lock portion is located on the front
20 side and second guide & lock portion is located on the back side of the support portion.

Example 9 includes the guide and support apparatus according to example 8, the first and second guide & lock portion are back to back, parallel and aligned with each other.

25 Example 10 includes the guide and support apparatus according to example 8, the first and second guide & lock portion are back to back, parallel and interleaved with each other.

Example 11 includes the guide and support apparatus according to any one of examples 1-10, wherein the guide & lock portion comprises
30 two ribs which extend up to the certain height from the support portion and connected by a lock portion on their top end, a slot extends between the two ribs and ends with the lock portion.

Example 12 includes the guide and support apparatus according to example 11, wherein the lock portion is positioned between the two ribs, and has a top surface and a front surface, wherein the front surface is lower than the front side of ribs such that a groove is defined by the front surface
5 of the lock portion and the two ribs.

Example 13 includes the guide and support apparatus according to example 11, wherein the lock portion is positioned between the two ribs, and has a top surface and a front surface, where two projections are formed next to the lock portion such that a groove is defined by the front surface
10 of the lock portion and the two projections.

Example 14 includes the guide and support apparatus according to example 12 or 13, wherein top surface of the lock portion is inclined relative to the front side of the ribs.

Example 15 includes a guide and support apparatus comprising a
15 support portion and a guide & lock portion, the guide & lock portion extends from the support portion vertically to a certain height, wherein the guide & lock portion includes first and second guide & lock portions, wherein the guide & lock portion comprises two ribs which extend up to a certain height from the support portion and connected by a lock portion on
20 their top end, a slot extends between the two ribs and ends with the lock portion.

Example 16 includes the guide and support apparatus according to example 15, wherein multiple guide & lock portions on the support portion are grouped into first guide & lock portion and second guide & lock portion,
25 the first guide & lock portion is located on the front side and second guide & lock portion is located on the back side of the support portion.

Example 17 includes the guide and support apparatus according to example 16, the first and second guide & lock portion are back to back, parallel and aligned or interleaved with each other.

30 Example 18 includes the guide and support apparatus according to any of examples 15-17, wherein the lock portion is positioned between the two ribs, and has a top surface and a front surface, wherein the front

surface is lower than the front side of ribs such that a groove is defined by the front surface of the lock portion and the two ribs.

Example 19 includes the guide and support apparatus according to any of examples 15-17, wherein the lock portion is positioned between the
5 two ribs, and has a top surface and a front surface, where two projections are formed next to the lock portion such that a groove is defined by the front surface of the lock portion and the two projections.

Example 20 includes a board matrix comprising a child board, a mother board, and the guide and support apparatus according to any of the
10 examples 1-19.

Example 21 includes a board matrix according to the example 20, further comprising a cover, the cover parallel to the guide and support apparatus and mounted at the edge of mother board, wherein several
15 trenches are formed such that the trenches are parallel to and aligned with the slot on the guide & lock portion.

Example 22 includes a method for manufacturing a guide and support apparatus comprising: forming a support portion; forming a guide & lock
20 portion which extends from the support portion to a certain height; and forming a mounting portion; wherein the support portion extending perpendicularly to the guide & lock portion and ended at the mounting portion; the mounting portion extends downward from one or two ends of the support portion and comprises a lock structure; the lock structure is below the support portion.

Although specific embodiments have been illustrated and described
25 herein, it will be appreciated by those of ordinary skill in the art that any arrangement, which is calculated to achieve the same purpose, may be substituted for the specific embodiments shown. Therefore, it is manifestly intended that this invention be limited only by the claims and the equivalents thereof.

CLAIMS

What is claimed is:

Claim 1. A guide and support apparatus, comprising:

5 a mounting portion, a support portion and a guide & lock portion, wherein

the support portion extending to the guide & lock portion and ended at the mounting portion;

10 the mounting portion extends downward from one or two ends of the support portion and comprises a lock structure; and

the guide & lock portion extends from the support portion to a certain height.

Claim 2. The guide and support apparatus according to claim 1, wherein the support portion comprises a top surface and a bottom surface, 15 the lock structure is a hole formed in the support portion, and the hole is below the bottom surface.

Claim 3. The guide and support apparatus according to any one of claims 1-2, wherein the guide & lock portion is arranged to guide a child board, and the mounting portion can be mounted to a mother board via the 20 lock structure such that the guide and support apparatus is mounted to the mother board.

Claim 4. The guide and support apparatus according to any one of claims 1-3, wherein guide & lock portion includes first and second guide & lock portions which is located on the front side and back side of the 25 support portion respectively, the first and second guide & lock portions are back to back, parallel and aligned or interleaved with each other.

Claim 5. The guide and support apparatus according to any one of claims 1-4, wherein the guide & lock portion comprises two ribs which extend up to the certain height from the support portion and connected by 30 a lock portion on their top end, a slot extends between the two ribs and ends with the lock portion.

Claim 6. The guide and support apparatus according to claim 5, wherein

the lock portion is positioned between the two ribs, and has a top surface and a front surface, wherein the front surface is lower than the front side of ribs such that a groove is defined by the front surface of the lock portion and the two ribs, wherein the top surface of the lock portion is inclined relative to the front side of the ribs; or

the lock portion is positioned between the two ribs, and has a top surface and a front surface, where two projections are formed next to the lock portion such that a groove is defined by the front surface of the lock portion and the two projections, wherein the top surface of the lock portion is inclined relative to the front side of the ribs.

Claim 7. A guide and support apparatus, comprising

a support portion and a guide & lock portion, the guide & lock portion extends from the support portion to a certain height, wherein the guide & lock portion includes first and second guide & lock portions, wherein the guide & lock portion comprises two ribs which extend up to a certain height from the support portion and connected by a lock portion on their top end, a slot extends between the two ribs and ends with the lock portion,

wherein the lock portion is positioned between the two ribs, and has a top surface and a front surface, two projections are formed next to the lock portion such that a groove is defined by the front surface of the lock portion and the two projections,

wherein the top surface of the lock portion is inclined relative to the front side of the ribs.

Claim 8. A board matrix comprising a child board, a mother board, and the guide and support apparatus according to any of the claims 1-7.

Claim 9. the board matrix according to the claim 8, further comprising a cover, the cover parallel to the guide and support apparatus and mounted at the edge of mother board, wherein several trenches are

formed such that the trenches are parallel to and aligned with the slot on the guide & lock portion.

Claim 10. A method for manufacturing a guide and support apparatus comprising:

5 forming a support portion;

forming a guide & lock portion which extends from the support portion to a certain height; and

forming a mounting portion;

10 wherein the support portion extending to the guide & lock portion and ended at the mounting portion; the mounting portion extends downward from one or two ends of the support portion and comprises a lock structure; the lock structure is below the support portion.

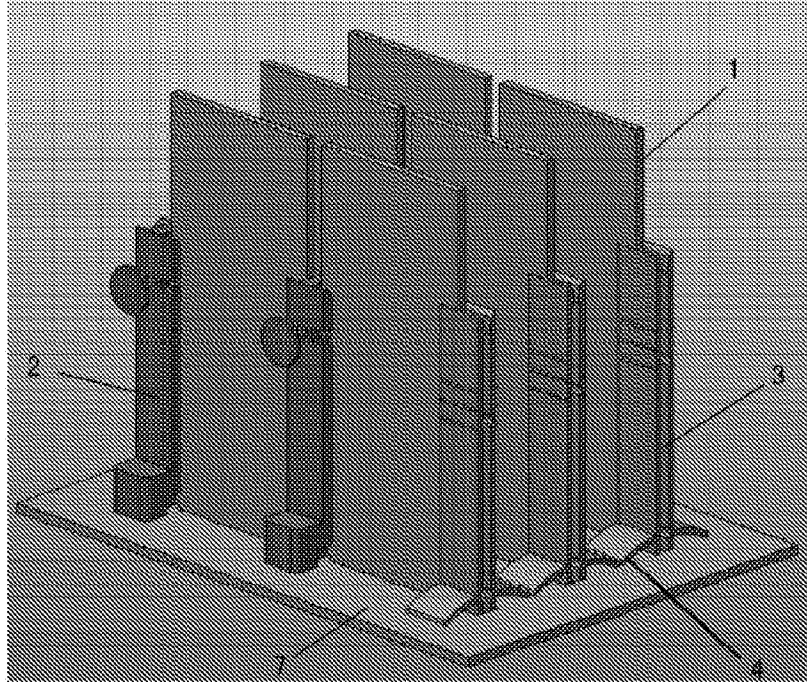

Fig. 1A

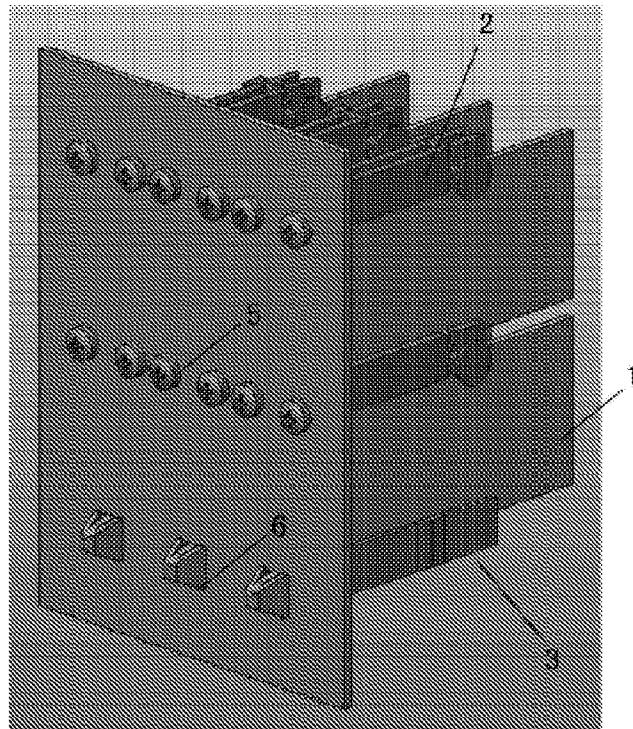

Fig. 1B

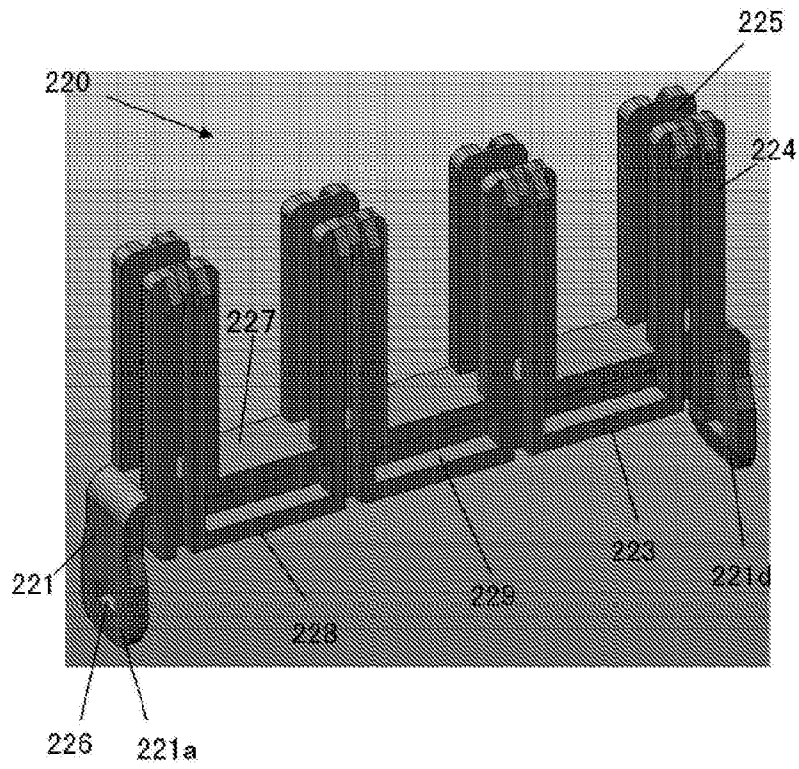

Fig. 2A

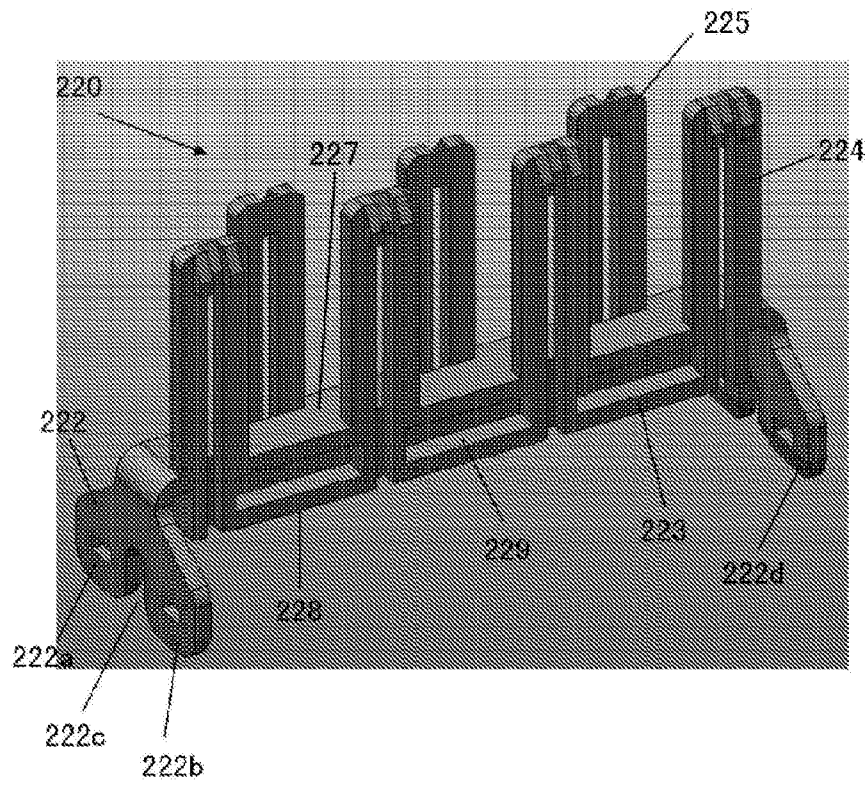

Fig. 2B

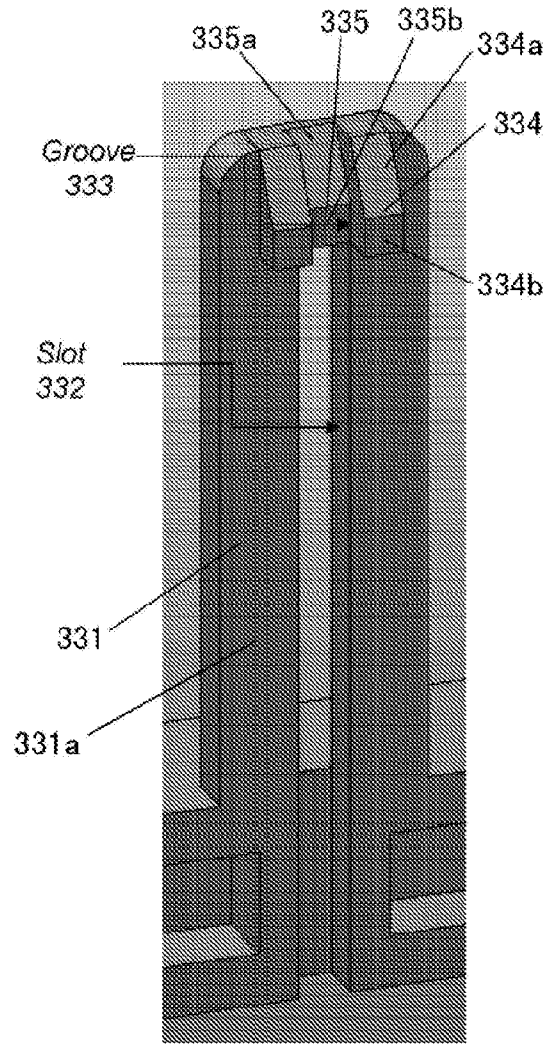

Fig. 3

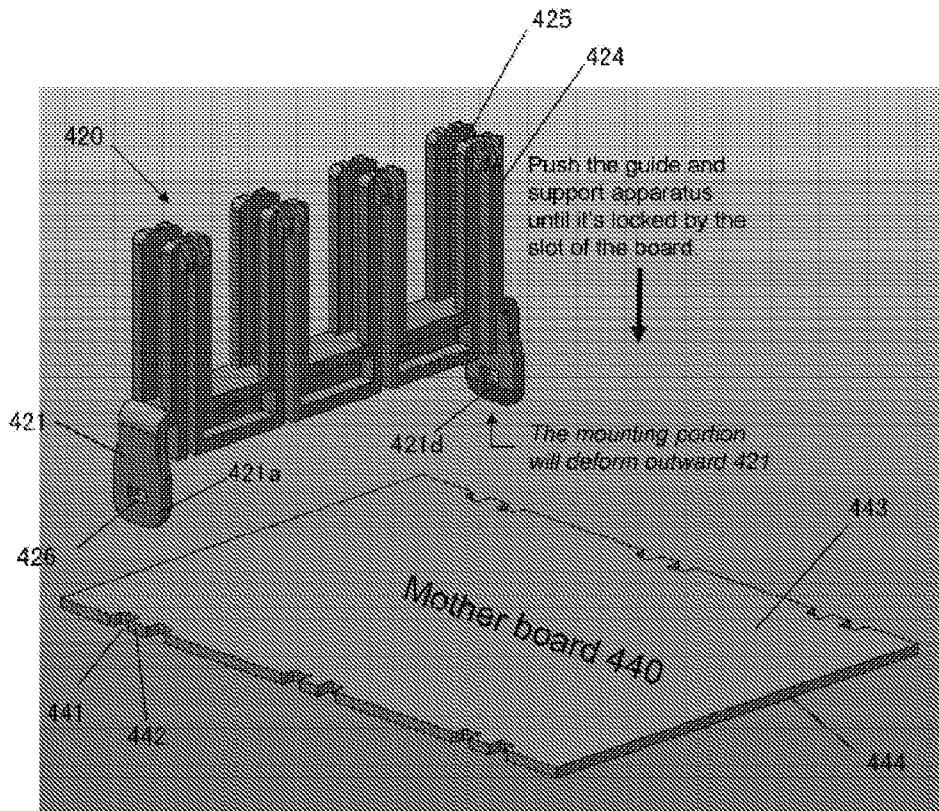

Fig. 4

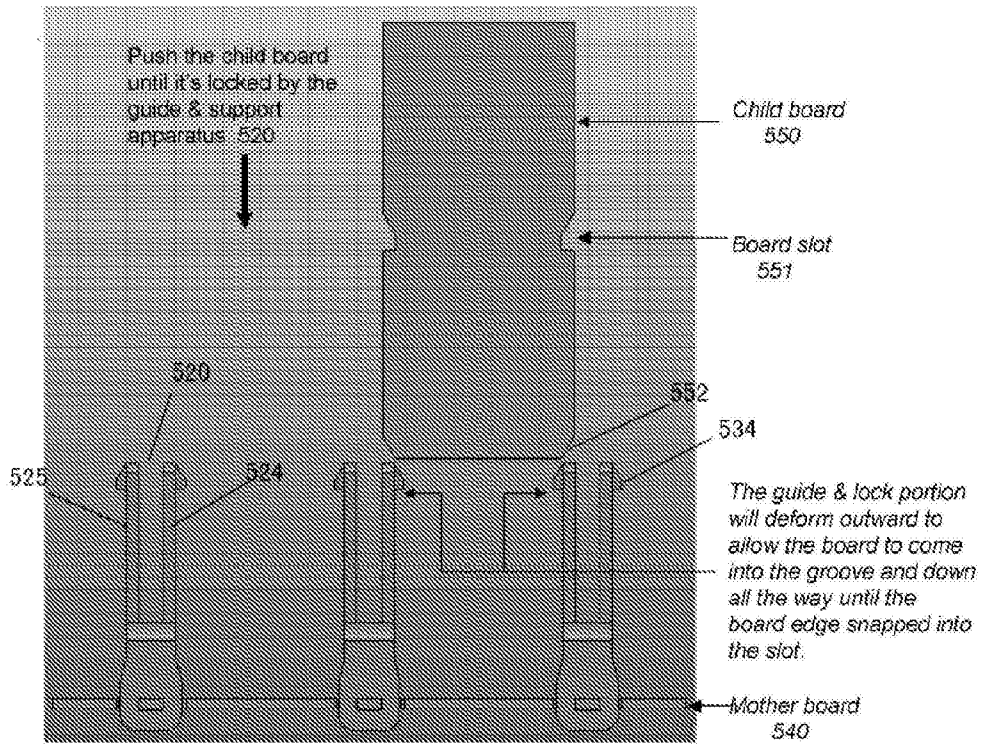

Fig. 5A

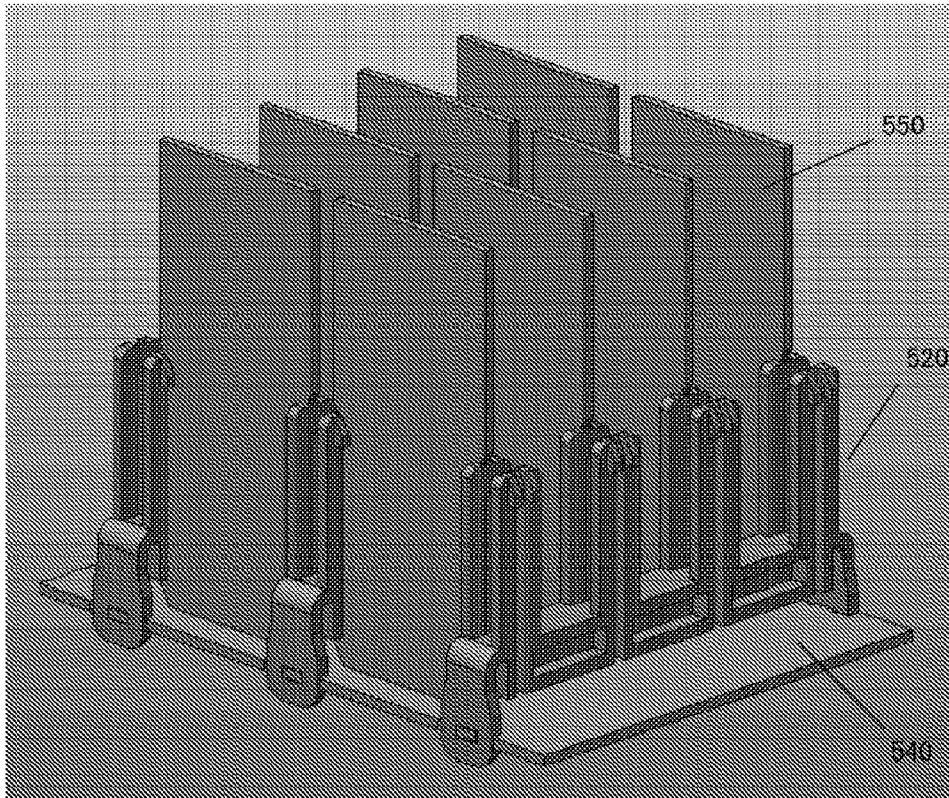

Fig. 5B

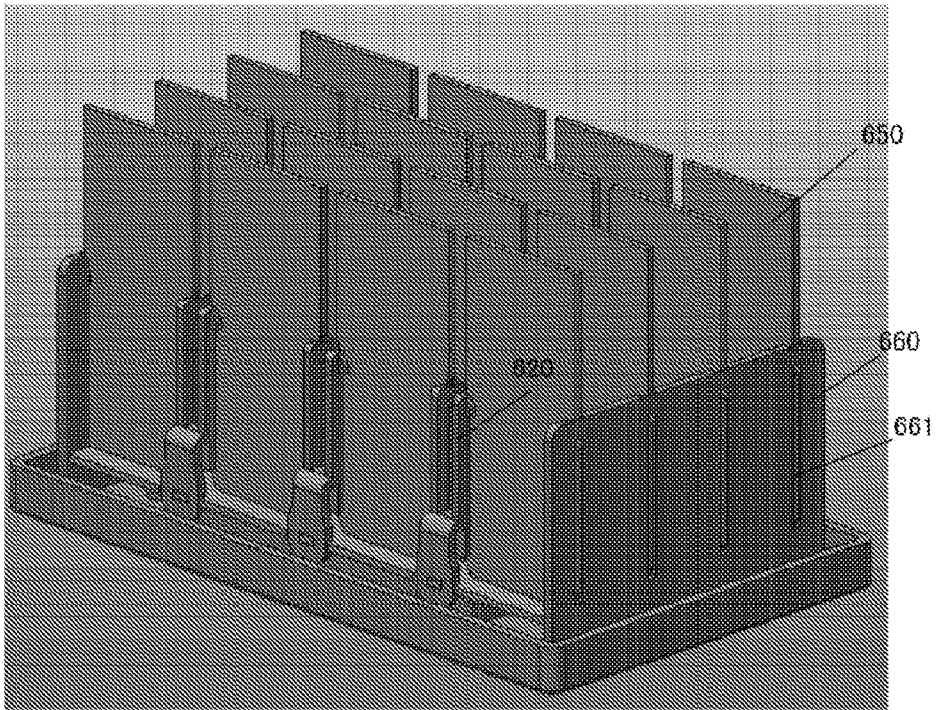
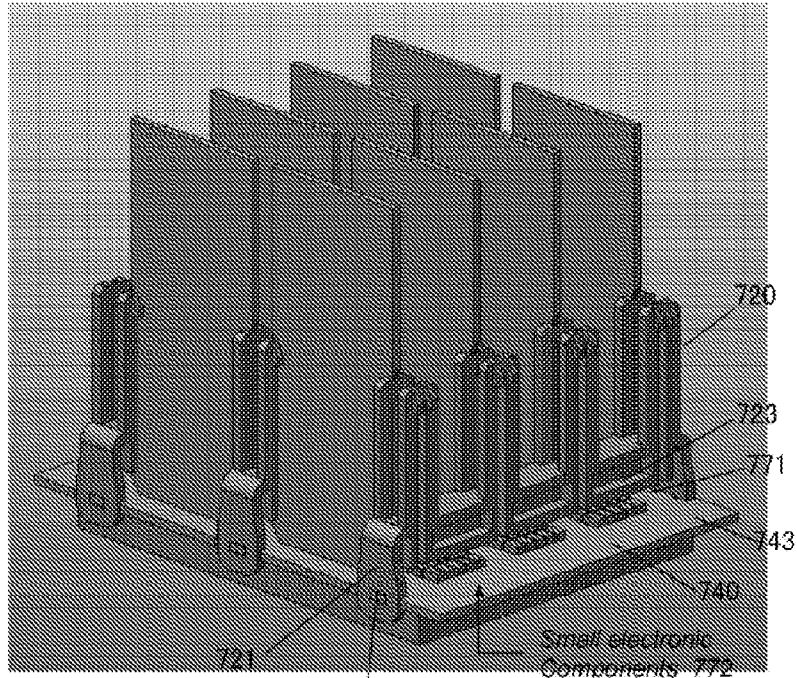

Fig. 6



726
Fig. 7A

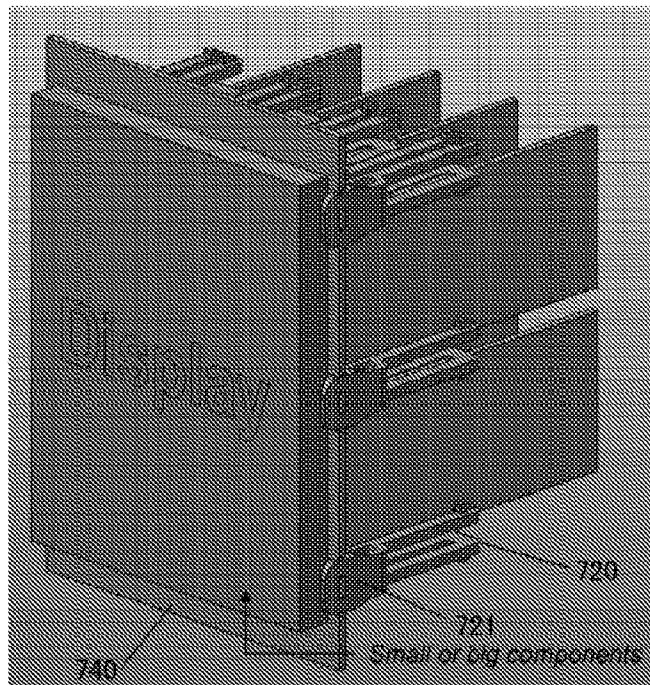

Fig. 7B

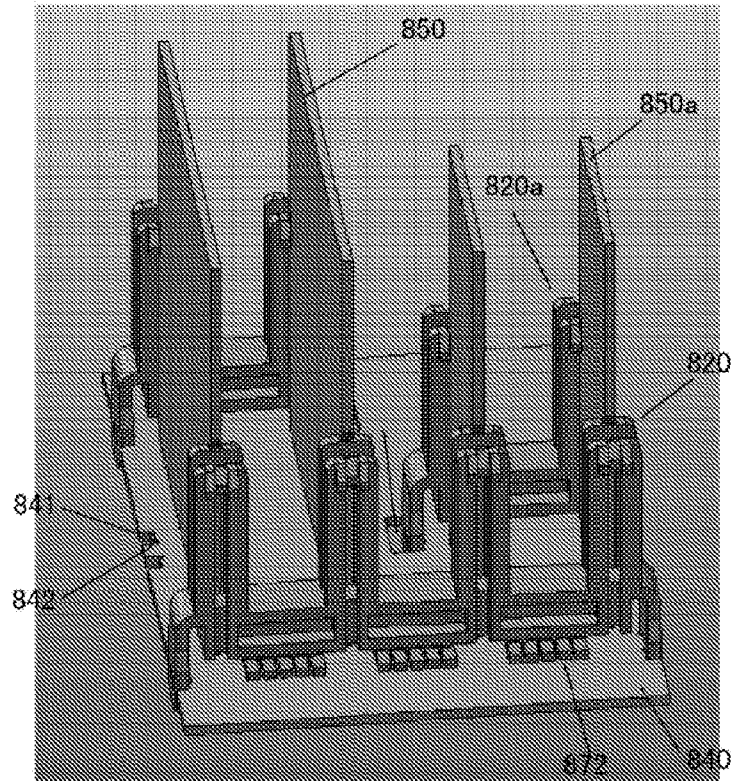

Fig. 8A

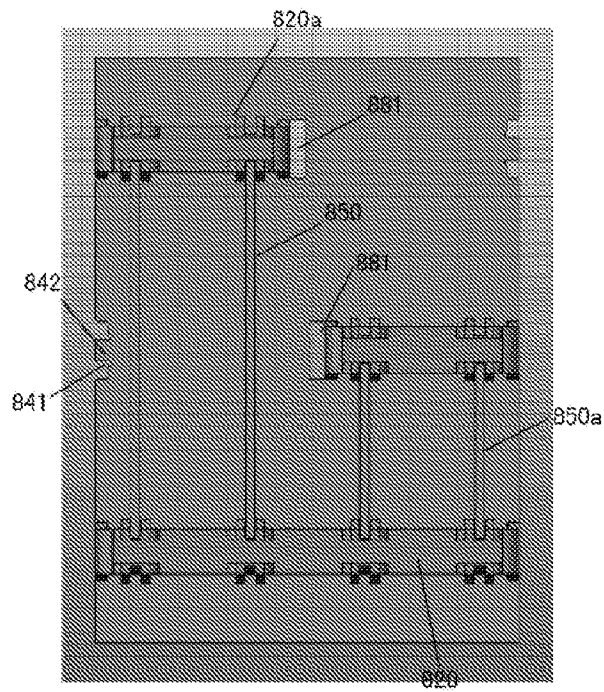

Fig. 8B

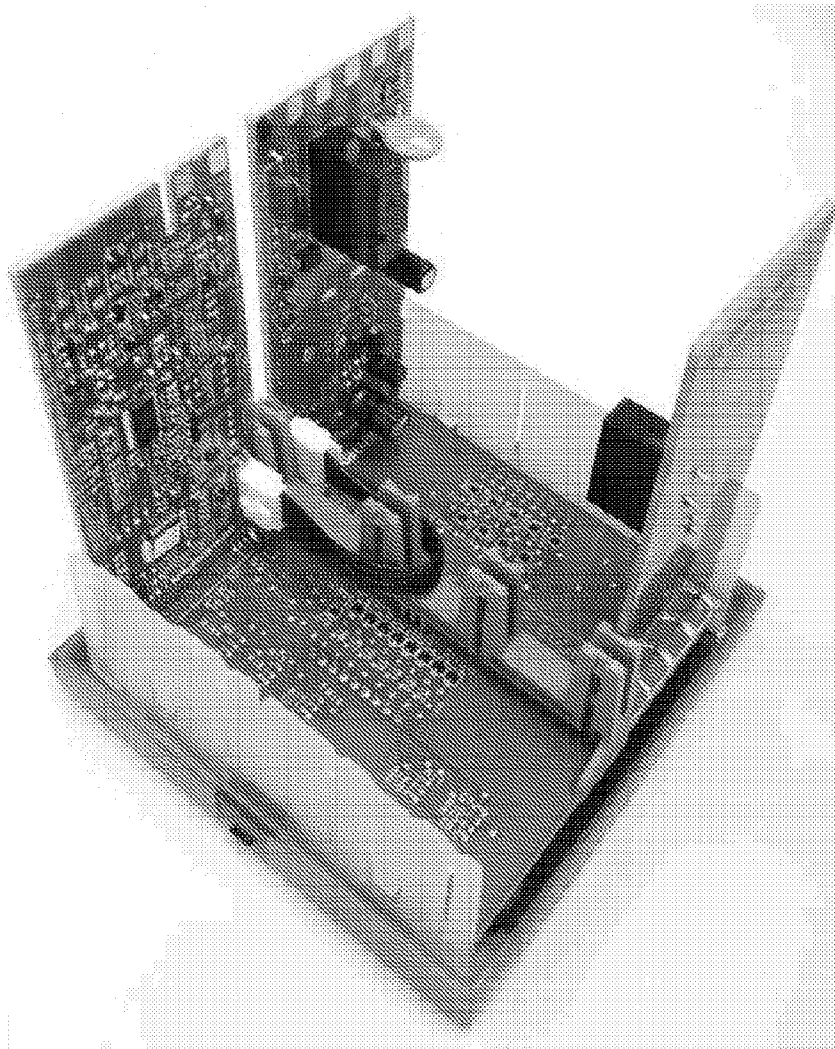

Fig. 9

INTERNATIONAL SEARCH REPORT

International application No.
PCT/CN2015/091180

A. CLASSIFICATION OF SUBJECT MATTER		
H01R 12/72(2011.01)i		
According to International Patent Classification (IPC) or to both national classification and IPC		
B. FIELDS SEARCHED		
Minimum documentation searched (classification system followed by classification symbols)		
H01R; H05K		
Documentation searched other than minimum documentation to the extent that such documents are included in the fields searched		
Electronic data base consulted during the international search (name of data base and, where practicable, search terms used)		
CNPAT,CNKI,WPLEPODOC:guide,support,lock,print,circuit,board,space,hole,vent,aperture,pore,slot,mother,child,vertical,perpendicular		
C. DOCUMENTS CONSIDERED TO BE RELEVANT		
Category*	Citation of document, with indication, where appropriate, of the relevant passages	Relevant to claim No.
X	CN 201773984 U (FOXCONN KUNSHAN COMP. INTERFACE ET AL.) 23 March 2011 (2011-03-23) description, paragraphs[17]-[26], figures 1-9	1,3,5,8,10
A	CN 201041843 Y (FOXCONN KUNSHAN COMP. INTERFACE ET AL.) 26 March 2008 (2008-03-26) the whole document	1-10
A	US 4008942 A (GENERAL SIGNAL CORP.) 22 February 1977 (1977-02-22) the whole document	1-10
A	US 5267872 A (FOXCONN INT. INC.) 07 December 1993 (1993-12-07) the whole document	1-10
<input type="checkbox"/> Further documents are listed in the continuation of Box C. <input checked="" type="checkbox"/> See patent family annex.		
* Special categories of cited documents: "A" document defining the general state of the art which is not considered to be of particular relevance "E" earlier application or patent but published on or after the international filing date "L" document which may throw doubts on priority claim(s) or which is cited to establish the publication date of another citation or other special reason (as specified) "O" document referring to an oral disclosure, use, exhibition or other means "P" document published prior to the international filing date but later than the priority date claimed "T" later document published after the international filing date or priority date and not in conflict with the application but cited to understand the principle or theory underlying the invention "X" document of particular relevance; the claimed invention cannot be considered novel or cannot be considered to involve an inventive step when the document is taken alone "Y" document of particular relevance; the claimed invention cannot be considered to involve an inventive step when the document is combined with one or more other such documents, such combination being obvious to a person skilled in the art "&" document member of the same patent family		
Date of the actual completion of the international search	08 June 2016	Date of mailing of the international search report
		15 June 2016
Name and mailing address of the ISA/CN	Authorized officer	
STATE INTELLECTUAL PROPERTY OFFICE OF THE P.R.CHINA 6, Xitucheng Rd., Jimen Bridge, Haidian District, Beijing 100088, China	ZHANG,Kaile	
Facsimile No. (86-10)62019451	Telephone No. (86-10)62413022	

INTERNATIONAL SEARCH REPORT
Information on patent family members

International application No. PCT/CN2015/091180

Patent document cited in search report			Publication date (day/month/year)	Patent family member(s)			Publication date (day/month/year)
CN	201773984	U	23 March 2011	US	8070499	B2	06 December 2011
				US	2011065297	A1	17 March 2011
CN	201041843	Y	26 March 2008	US	2008220642	A1	11 September 2008
				US	7677907	B2	16 March 2010
US	4008942	A	22 February 1977	None			
US	5267872	A	07 December 1993	None			