



(86) Date de dépôt PCT/PCT Filing Date: 2005/04/19
 (87) Date publication PCT/PCT Publication Date: 2005/12/15
 (45) Date de délivrance/Issue Date: 2013/08/20
 (85) Entrée phase nationale/National Entry: 2006/11/21
 (86) N° demande PCT/PCT Application No.: US 2005/013283
 (87) N° publication PCT/PCT Publication No.: 2005/118028
 (30) Priorité/Priority: 2004/05/27 (US10/855,857)

(51) Cl.Int./Int.Cl. *A61M 5/142* (2006.01),
A61M 5/168 (2006.01)

(72) Inventeurs/Inventors:
 STEWART, JANICE, US;
 MEINZER, RANDOLPH, US;
 BELLO, DEBRA K., US;
 MULLAN, JANET, US;
 WONG, LAI H., US;
 TODD, BRETT, US;
 KIVLEHAN, TODD, US

(73) Propriétaire/Owner:
 BAXTER INTERNATIONAL INC., US

(74) Agent: SIM & MCBURNEY

(54) Titre : SYSTEME D'ALARME MULTI-ETATS POUR UNE POMPE MEDICALE
 (54) Title: MULTI-STATE ALARM SYSTEM FOR A MEDICAL PUMP

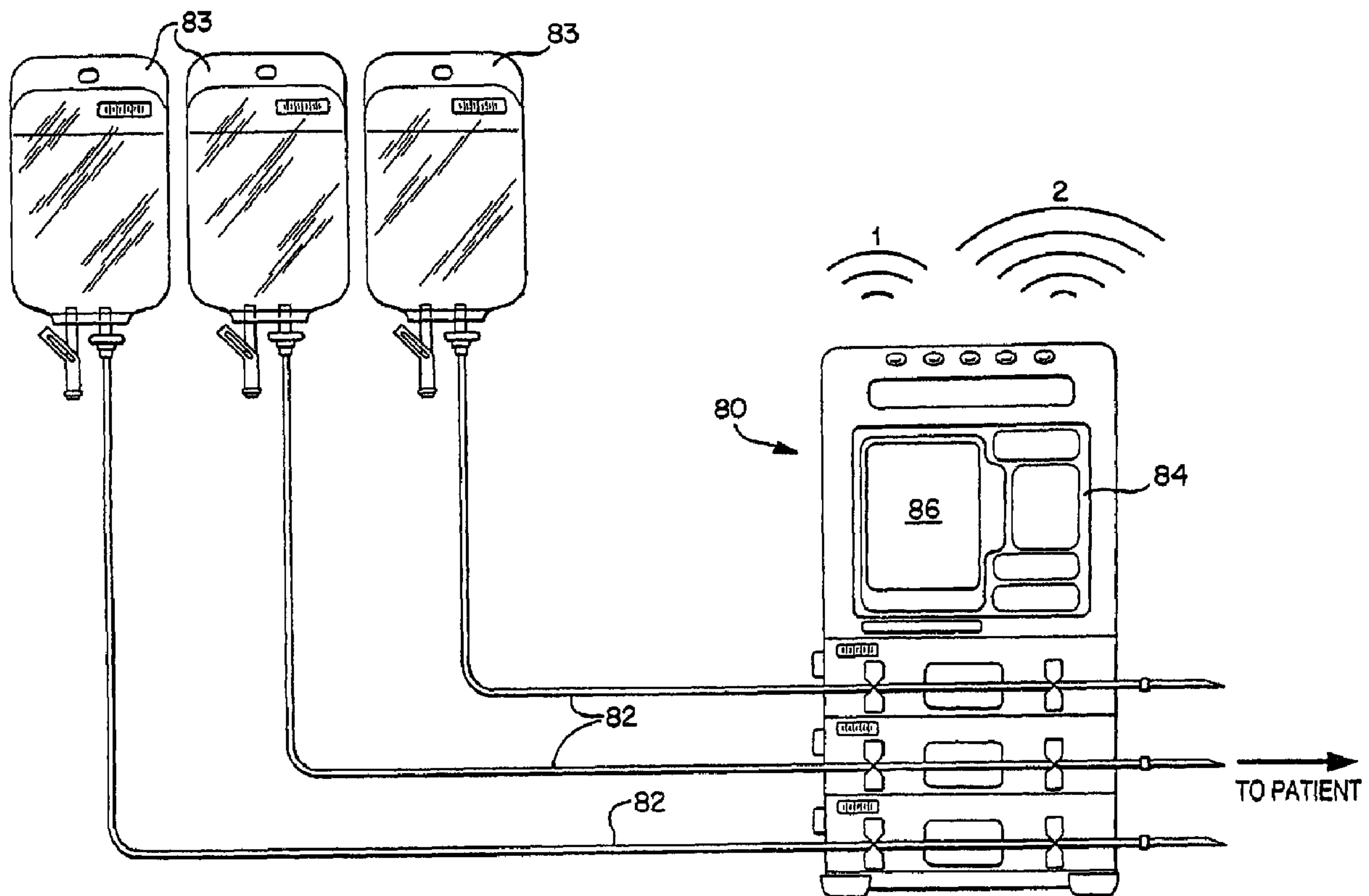

(57) Abrégé/Abstract:

An alarm system (52) for a medical pump (50) associated with delivering a fluid (54) to a patient in connection with treatment of the patient is provided. The alarm system (52) comprises an alarm (60) associated with at least one treatment parameter. The alarm (60) includes a first alarm state (1) associated with a first event relating to the treatment parameter and a second alarm state (2) associated with a second event. The second alarm state (2) is discernable from the first alarm state (1), which will allow each of the events to be treated differently by a caregiver.



(12) INTERNATIONAL APPLICATION PUBLISHED UNDER THE PATENT COOPERATION TREATY (PCT)

(19) World Intellectual Property
Organization
International Bureau



(43) International Publication Date
15 December 2005 (15.12.2005)

PCT

(10) International Publication Number
WO 2005/118028 A1

(51) International Patent Classification⁷: **A61M 5/142,**
5/168

(21) International Application Number:
PCT/US2005/013283

(22) International Filing Date: 19 April 2005 (19.04.2005)

(25) Filing Language: English

(26) Publication Language: English

(30) Priority Data:
10/855,857 27 May 2004 (27.05.2004) US

(71) Applicant (for all designated States except US): **BAXTER INTERNATIONAL INC.** [US/US]; ONE BAXTER PARKWAY, DEERFIELD, IL 60015 (US).

(72) Inventors; and

(75) Inventors/Applicants (for US only): **STEWART, Janice** [US/US]; 1202 Barclay Circle, Inverness, IL 60010 (US). **MEINZER, Randolph** [US/US]; 1703 Spruce Street, Spring Grove, IL 60081 (US). **BELLO, Debra, K.** [US/US]; 223 West Congressional Court, Vernon Hills, IL 60061 (US). **MULLAN, Janet** [US/US]; 23459 Eagle

Nest Road, Antioch, IL 60002 (US). **WONG, Lai, H.** [SG/US]; 805 Marseilles Circle, Buffao Grove, IL 60089 (US). **TODD, Brett** [US/US]; 1970 Marigold Lane, Round Lake, IL 60073 (US). **KIVLEHAN, Todd** [US/US]; 435 Wicks Street, Grayslake, IL 60030 (US).

(74) Agents: **FOLEY, Austin, J.** et al.; Baxter International Inc., One Baxter Parkway, Deerfield, IL 60015 (US).

(81) Designated States (unless otherwise indicated, for every kind of national protection available): AE, AG, AL, AM, AT, AU, AZ, BA, BB, BG, BR, BW, BY, BZ, CA, CH, CN, CO, CR, CU, CZ, DE, DK, DM, DZ, EC, EE, EG, ES, FI, GB, GD, GE, GH, GM, HR, HU, ID, IL, IN, IS, JP, KE, KG, KM, KP, KR, KZ, LC, LK, LR, LS, LT, LU, LV, MA, MD, MG, MK, MN, MW, MX, MZ, NA, NI, NO, NZ, OM, PG, PH, PL, PT, RO, RU, SC, SD, SE, SG, SK, SL, SM, SY, TJ, TM, TN, TR, TT, TZ, UA, UG, US, UZ, VC, VN, YU, ZA, ZM, ZW.

(84) Designated States (unless otherwise indicated, for every kind of regional protection available): ARIPO (BW, GH, GM, KE, LS, MW, MZ, NA, SD, SL, SZ, TZ, UG, ZM, ZW), Eurasian (AM, AZ, BY, KG, KZ, MD, RU, TJ, TM),

[Continued on next page]

(54) Title: MULTI-STATE ALARM SYSTEM FOR A MEDICAL PUMP

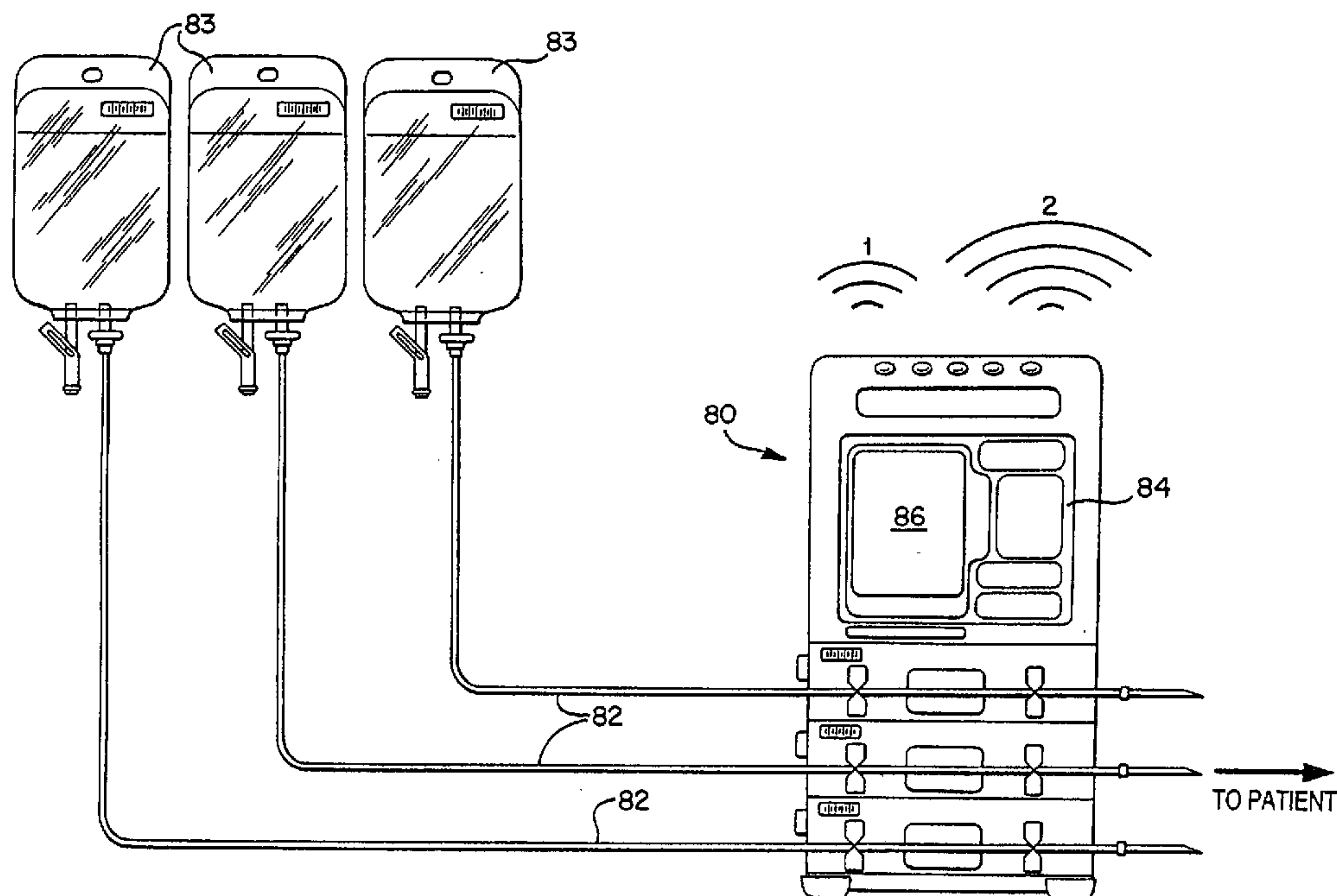

(57) Abstract: An alarm system (52) for a medical pump (50) associated with delivering a fluid (54) to a patient in connection with treatment of the patient is provided. The alarm system (52) comprises an alarm (60) associated with at least one treatment parameter. The alarm (60) includes a first alarm state (1) associated with a first event relating to the treatment parameter and a second alarm state (2) associated with a second event. The second alarm state (2) is discernable from the first alarm state (1), which will allow each of the events to be treated differently by a caregiver.

WO 2005/118028 A1

WO 2005/118028 A1



European (AT, BE, BG, CH, CY, CZ, DE, DK, EE, ES, FI, FR, GB, GR, HU, IE, IS, IT, LT, LU, MC, NL, PL, PT, RO, SE, SI, SK, TR), OAPI (BF, BJ, CF, CG, CI, CM, GA, GN, GQ, GW, ML, MR, NE, SN, TD, TG).

For two-letter codes and other abbreviations, refer to the "Guidance Notes on Codes and Abbreviations" appearing at the beginning of each regular issue of the PCT Gazette.

Published:

— *with international search report*

MULTI-STATE ALARM SYSTEM FOR A MEDICAL PUMP**DESCRIPTION****5 Technical Field**

The instant invention relates to alarm systems for use with medical delivery pumps for delivery of therapeutic fluids to a patient.

Background of the Invention

10 The administration of therapeutic fluids to a patient is well known in the art. Many types of medical delivery devices exist to deliver various therapeutic fluids to a patient, such as, for example, parenteral fluids, drugs or other medicaments, electrolytes, blood and blood products, and the like. One particular type of medical delivery device is an infusion pump, which can deliver one or more of these therapeutic fluids to a patient via a variety of
15 administration types, such as, for example, intravenous (IV), intra-arterial (IA), subcutaneous, epidural, irrigation of fluid spaces applications, and the like. Many infusion pumps that operate under these types of administration typically utilize an administration line set and an associated container containing one or more therapeutic fluids. The line set is typically loaded into a delivery mechanism of the pump, which facilitates delivery of the fluid to the
20 patient.

Each type of administration and each type of therapeutic fluid typically involve numerous operational parameters, variables, constraints and other related information, such as medical and pharmaceutical related information, that must be monitored and followed to

ensure proper, effective and safe delivery of therapeutic fluids to the patient and effective treatment of the patient. To ensure proper monitoring and treatment, most medical delivery pumps incorporate an alarm system to indicate to a caregiver or patient that an event has occurred, such as one or more operational parameters being out of a predetermined range.

5 These alarms are typically visual or audible alarms, such as a beeping alarm.

In addition to medical delivery devices, most medical equipment that is utilized in direct patient care typically have alarm systems to notify the caregiver of situations that require attention. While the intent of these alarms is to notify the caregiver of such situations and allow them to be addressed, the sheer number of alarm systems of equipment that may be associated with treatment of a particular patient, and the frequency of such alarms being triggered and high levels of patient acuity, have ultimately minimized the sense of urgency in responding to such alarms. This can result in a potentially dangerous situation, particularly in the case of medical pumps utilized to properly and safely deliver fluids, such as drugs, to a patient.

15 To address this concern, there is a need to distinguish between alarms, and in the case of medical pumps, there is a need to distinguish between alarms associated with the same or separate events that occur in connection with the same or separate devices.

The present invention addresses these and other concerns and generally provides a new and improved alarm system for a medical pump for delivery of medicaments to a patient.

20

Summary of the Invention

The present invention generally provides an alarm system for a medical pump associated with delivering a medicament or fluid to a patient in connection with treatment of the patient. According to a particular aspect of the invention, there is provided an alarm system for a medical pump associated with delivering a medicament to a patient, the alarm system comprising an alarm associated with at least one treatment parameter, the alarm having a first alarm state associated with a first event relating to the at least one treatment parameter, and a second alarm state associated with a second event, the second alarm state discernable from the first alarm state, and wherein the second event is defined by expiration of an amount of time measured from occurrence of the first event. This will allow each of the events to be treated differently by a caregiver.

35 According to other aspects of the invention, the alarm may be audible, the alarm may be visual, the alarm may have both audible and visual components, the second alarm state may have a volume level that is discernable from the first alarm state, the second alarm state may have a tone that is discernable from the first alarm state, the second alarm state may have

a frequency that is discernable the first alarm state, and/or the second alarm state may have an appearance that is discernable from the first alarm state.

According to another aspect of the invention, the second event relates to the at least one treatment parameter.

5 According to yet another aspect of the invention, the second event relates to a treatment parameter different from the at least one treatment parameter.

According to yet another aspect of the invention, the second event is defined by expiration of an amount of time measured from occurrence of the first event.

10 According to yet another aspect of the invention, the second event is defined by a deviation from a value associated with the at least one treatment parameter.

According to yet another aspect of the invention, the at least one treatment parameter is associated with the pump.

According to yet another aspect of the invention, the at least one treatment parameter is associated with a source external to the pump.

15 According to yet another aspect of the invention, an alarm signal associated with the alarm states is routed to a device external to the pump.

According to a further aspect of the invention, the treatment parameter may be associated with a measurement from the patient, operation of the pump, and/or the fluid.

20 According to yet another aspect of the invention, the second event may be associated with a life-threatening situation for the patient.

According to yet another aspect of the invention, the pump will shut off when the alarm is in the second alarm state.

According to yet another aspect of the invention, the events can be set by a user.

25 According to yet another aspect of the invention, the second alarm state will only be operational with a particular fluid. The identification of the particular fluid may be stored in a memory associated with the pump.

According to yet another aspect of the invention, the alarm system can be customizable and include a near-end alert/alarm feature.

30 According to yet another aspect of the invention, the alarm system can be incorporated into different types of infusion pumps in including a micro electro-mechanical systems (MEMS) pump.

According to another particular aspect of the invention there is provided an alarm system for a medical pump associated with delivering a medicament to a patient, the alarm system comprising an alarm associated with at least one treatment parameter, the alarm having a first alarm state associated with a first event relating to the at least one treatment parameter, and a second alarm state associated with a second event relating to the at least one treatment parameter, the second alarm state discernable from the first alarm state, and wherein the second event is associated with a life-threatening situation for the patient.

According to yet another particular aspect of the invention there is provided an alarm system for a medical pump for delivering a therapeutic fluid to a patient, the alarm system comprising an alarm associated with at least one operating parameter, the alarm having a first alarm state and a second alarm state, the first alarm state indicating a non-critical deviation from an original value of the at least one operating parameter, the second alarm state discernable from the first alarm state and indicating a critical deviation from the original value of the at least one operating parameter.

According to yet another particular aspect of the invention there is provided an alarm system for a medical pump associated with delivering a fluid to a patient in connection with treatment of the patient, the alarm system comprising an alarm associated with at least one treatment parameter, the alarm having a first alarm state associated with a first event relating to the at least one treatment parameter, and a second alarm state associated with a second event relating to the at least one treatment parameter, the second alarm state discernable from the first alarm state; and a snooze element that, when activated, enables the second alarm state to be activated upon occurrence of the second event.

According to yet another particular aspect of the invention there is provided an alarm system for a medical device used in connection with treatment of a patient, the alarm system comprising an alarm associated with at least one treatment parameter, the alarm having a first alarm state associated with a first event relating to the at least one treatment parameter, and a second alarm state associated with a second event relating to the at least one treatment parameter, the second alarm state discernable from the first alarm state; and a snooze element that, when activated, enables the second alarm state to be activated upon occurrence of the second event.

According to yet another particular aspect of the present invention there is provided a pump assembly associated with delivering a medicament to a patient, the pump assembly comprising a micro electro-mechanical system (MEMS) pump having an alarm system having an alarm associated with at least one treatment parameter, the alarm having a first alarm state associated with a first event relating to the at least one treatment parameter, and a second alarm state associated with a second event, the second alarm state discernable from the first alarm state, and wherein the second event is defined by expiration of an amount of time measured from occurrence of the first event.

According to yet another particular aspect of the present invention there is provided a pump assembly associated with delivery of a medicament to a patient, the pump assembly comprising a micro electro-mechanical system (MEMS) pump having an alarm system having an alarm associated with at least one treatment parameter, the alarm having a first alarm state associated with a first event relating to the at least one treatment parameter, and a second alarm state associated with a second event relating to the at least one treatment parameter, the second alarm state discernable from the first alarm state; and a snooze element that, when activated, enables the second alarm state to be activated upon occurrence of the second event.

These and other aspects of the present invention will be apparent from the drawings and written specification set forth herein, including the appended claims.

Brief Description of the Drawings

5 FIG. 1 is a schematic diagram generically depicting an infusion pump having an alarm system in accordance with the principles of the present invention.

FIG. 2 is a schematic diagram depicting an infusion pump having an alarm system that includes an audible component in accordance with the principles of the present invention.

10 FIG. 3 is a screen shot of a display of the infusion pump depicted in FIG. 3, which illustrates an exemplary visual first alarm state of the alarm system.

FIG. 4 is a screen shot of a display of the infusion pump depicted in FIG. 3, which illustrates an exemplary visual second alarm state of the alarm system.

15 FIG. 5 is a schematic diagram generically depicting an infusion pump having an alarm system in communication with at least one external device in accordance with the principles of the present invention.

FIG. 6 is a schematic diagram of an alternate embodiment of the alarm system of the present invention incorporating a near-end alert/alarm feature or snooze feature.

FIG. 7 is a schematic diagram of an example of a particular embodiment and application of the alarm system of the present invention.

20 FIG. 8 is a schematic diagram of an alternative embodiment of the alarm system of the present invention.

Detailed Description of the Preferred Embodiments

25 While this invention is susceptible to embodiments in many different forms, there are shown in the drawings and herein described in detail, preferred embodiments of the invention with the understanding that the present disclosures are to be considered as exemplifications of the principles of the invention and are not intended to limit the broad aspects of the invention to the embodiments illustrated.

30 FIG. 1 generically depicts a medical fluid delivery pump 50 having an alarm system 52 in accordance with the principles of the present invention. As is well known in the art, the pump 50 is utilized to deliver a medicament 54, or fluid 54, to a patient via a line set 56 and associated container 58 containing the fluid 54. The pump 50 is preferably a microprocessor-

based pump that is capable of being programmed, utilizing software and/or firmware, to facilitate operation and functionality of the pump 50. One preferred embodiment of the pump 50 is the one disclosed in U.S. Patent Nos. 5,782,805 and 5,842,841.

In a preferred embodiment, the alarm system 52 comprises an alarm 60 having a first alarm state and associated alarm signal (indicated by the speaker icon labeled as "1" in FIG. 1) and a second alarm state and associated alarm signal (indicated by the speaker icon labeled as "2" in FIG. 1). However, any number of alarm states and associated signals could be provided in accordance with the principles of the present invention. The alarm 60 of the alarm system 52 is preferably associated with at least one treatment parameter in connection with treatment of a patient. The treatment parameter may be associated with the pump 50, or it may be associated with an external source that is in communication with the pump alarm system 52. Examples of treatment parameters may include a value representing an infusion rate of a therapeutic fluid being delivered to a patient by a volumetric infusion pump, information relating to operation of the pump, the identification of a drug being delivered to a patient, a measurement taken from a patient by the pump or an external source, or any other information or data associated with the treatment of a patient. As used herein, the term "treatment parameter" is defined to encompass all of the above-described parameters as well as any other types or forms of data, values, parameters, information, units of time, or any discrete measurement or piece of data in connection with treatment of a patient. The alarm 60 is customizable and also can be pre-programmed or set by a caregiver such as at the bedside.

According to a particular aspect of the invention, the first alarm state is preferably associated with a first event relating to a treatment parameter, and the second alarm state is associated with a second event relating to the same or another treatment parameter. The second alarm state is discernable from the first alarm state so that a caregiver can act appropriately to each of the alarm states should they occur during treatment. The alarm 60 can be audible, visual, or a combination thereof. The events may be any number of occurrences relating to the treatment of the patient, such as, for example, measurement of an elapsed time between events, measurement of a value of a treatment parameter, an occurrence relating to operation of the pump, an identification or determination made by the pump or an external device, etc.

In a particular embodiment, the second event can be defined by an amount of time that has expired since the first alarm state has been activated without being addressed by a caregiver. In such a case, the first and second events can be related to the same treatment parameter and the second alarm state is activated only when the particular amount of time has expired since activation of the first alarm state. The second alarm state may be in any form as described herein, such as, for example, an escalation of the frequency or tone of the first alarm state.

In yet another particular embodiment, the second event may be defined by a deviation from a particular value or range of values of a treatment parameter. In such a case, the first and second events can be related to the same treatment parameter. The first event may be defined by a first deviation value or range with respect to an original value of the treatment parameter and the second event may be defined by a second deviation value or range, wherein the second event may be measured with respect to either the original value of the treatment parameter or the first event. The original value may be a predetermined value, either pre-programmed or obtained by an external source. In this particular example, the second alarm state is activated only when a particular value of deviation has occurred with respect to the original value of the treatment parameter or the first event.

In yet another embodiment, the first and second events may be related to different treatment parameters. For example, if the events are each defined by a deviation from a particular value of a treatment parameter, the first and second alarm states would be activated by a deviation of its respective treatment parameters (i.e., first and second events). In such a case, the discernable alarm states would allow a caregiver to identify the particular event associated with the particular alarm state.

Preferably, the second alarm state is associated with an event that is critical, i.e., life-threatening to the patient or of a high level of importance that requires immediate attention, whereas the first alarm state is associated with an event that is non-critical, i.e., non-life-threatening to the patient or of a lower level of importance that does not require immediate attention. However, the alarm states can be customized to be associated with, or categorized by, any type of event or occurrence. The event can be any occurrence related to the treatment parameter, such as, for example, a deviation from the treatment parameter or a flag raised by a treatment protocol that is triggered by the treatment parameter. The events may be associated

with administration of a fluid to a patient, a measurement from a patient, the operation of the pump, or any other aspect of treatment.

Referring to FIG. 2, a pump 80 is shown having three line sets 82 loaded therein to facilitate delivery of three fluid types to a patient. The pump 80 is preferably an infusion pump. Each of the line sets 82 is associated with a container 83 containing a fluid being delivered to the patient. The pump 80 includes a user interface 84 having a display 86 that can be utilized for displaying a visual form of the alarm 60. Although not shown, a light indicator, such as an LED or other source of light, could be incorporated into the pump and act as a visual form of the alarm 60. FIG. 2 schematically depicts a first audible alarm state (1) and a second audible alarm state (2), wherein the second alarm state is discernable from the first alarm state because it is at a higher volume level than the first alarm state. The audible alarm states can also be discernable by tone, by frequency of an interval, by type of sound, or by any other means to create a perceptively different state between the two alarm states.

As already noted, the pump 80 of FIG. 2 can also incorporate a visual form of the alarm 60. As an example of a visual form of the alarm 60, FIG. 3 depicts a screenshot of the display 86 that shows an alert that may not be of a high level of importance and is therefore categorized as a first alarm state. In this example, a caregiver enabled a callback feature relating to a piggyback function of the pump 80. Thus, when the piggyback infusion has been completed and the pump channel has switched over to the primary rate, a first alarm state is activated in the form of an alert as shown on the screenshot in FIG. 3.

As an example of a visual form of the alarm 60 in the second alarm state, FIG. 4 depicts a screenshot of the display 86 that shows an alert that may be of a high level of importance and is therefore categorized as a second alarm state. In this example, a channel of the pump 80 has failed and is out of service. Since this may be critical, a second alarm state is activated in the form shown on the screenshot in FIG. 4. It is understood that in such a case, an audible alarm may also be incorporated into the alarm state as well.

In certain instances, it may be desirable to allow a user to program certain events to be associated with a particular alarm state. Preferably such programming is done by personnel authorized by a health care facility so that it can be in accordance with facility policy and procedures. In a particular embodiment, the second alarm state may be programmed to only be operational with a particular fluid, such as a particular drug. The alarm states can also be

programmed to indicate drug interaction situations. In such embodiments, the identification of a particular fluid having an associated alarm, or data tables or libraries indicating potential drug interactions, can be stored in a memory associated with the pump.

As shown in FIG. 5, according to another aspect of the invention, the alarm system 52 and associated alarm 60 can be linked to one or more external sources or devices 100, such that the alarm system 52 can be utilized by these external sources. In such a case, the external source or device 100 would be associated with the treatment parameter to be monitored. For example, a heart rate monitor or a pulse oximeter may be connected to the alarm system 52 to allow treatment parameters of these devices, and events relating to the treatment parameters of these devices, to be associated with the alarm states of the alarm system 52. In such cases, there may be several external devices or sources that utilize the alarm system 52 to provide an effective multi-state alarm.

As shown in FIG. 5, according to yet another aspect of the invention, the alarm system 52 may be in communication with an external device or system 150 to allow routing of an alarm state signal to that external device or system. For example, the external system 150 may be a centralized server or computer that could allow an alarm state and associated information, such as the associated event, treatment parameter, device, patient identification, or the like, to be routed to other devices, such as another computer, a personal digital assistant (PDA), pager, wireless e-mail device, wireless telephone or communicator, or the like. Such an arrangement expands the effectiveness of a multi-state alarm system.

It is understood that the alarm system 52 is customizable in a variety of different methods. For example, the system 52 can be set such that a first drug is associated with an alarm escalation wherein the alarm has a first state and a second state as described above. The system 52 is also set such that a second drug is not associated with an alarm escalation. The system 52 can further be set such that in non-critical alarms, the pump continues to run. However, with critical alarms, the pump is shut down.

FIG. 6 discloses a schematic diagram of yet another aspect of the alarm system 52 of the present invention. In this embodiment, the alarm system 52 incorporates a customizable near-end alert/alarm having a "snooze" feature 200, snooze element or delay element. This aspect allows a user to define or enable a second event 202 relative to a first event 204 or relative to when a caregiver addresses the first event 204. For example, the snooze feature 204 may define or enable the second event 202 in terms of: expiration of an amount of time

relative to either the first event 204 or when a caregiver addresses the first event 204; reaching a value of a treatment parameter relative to either the first event 204 or when a caregiver addresses the first event 204; or any other type of data, information, or parameter that may change relative to either the first event 204 or when a caregiver addresses the first event 204.

5 When the second event 202 occurs, a second alarm state 206 is activated wherein the second alarm state 206 is discernable from a first alarm state 208 associated with the first event 204. The snooze feature 200 may be configured such that additional events 210 may be thereafter defined, each associated with the second alarm state 206, or additional alarm states 212 that are all respectively discernable.

10 As already discussed above, in accordance with a particular embodiment, the second event 202 can be defined by an amount of time that has expired since the first alarm state 208 has been activated without being addressed by a caregiver. In a related aspect incorporating the snooze feature 200, when the caregiver addresses the first alarm state 208, the snooze feature 200 can be incorporated into the alarm system 52 to allow the caregiver to
15 acknowledge the first event 204 and define the second event 202 in terms of a predetermined amount of time measured relative to either the first event 204 or when the caregiver addressed the first event 204, i.e. a snooze interval 214. When the snooze feature 200 is activated by the caregiver, the second alarm state 206 is enabled and the second event 202 is set by a predetermined value or preprogrammed data stored in a memory, or by data entered or
20 obtained at the time of activation of the snooze feature 200, which represents the snooze interval 214. After expiration of the snooze interval 214, the second alarm state 206 is activated. The snooze feature 200 may be configured such that additional events 210 and associated snooze intervals may be thereafter defined by further activation of the snooze feature 200. The second alarm state 206, or one or more additional alarm states 212, may be
25 associated with these additional events 210.

As mentioned above, in a particular embodiment, the snooze feature or snooze element 200 may define the second event 202 in terms of a predetermined value of a treatment parameter relative to the first event 204 or when a caregiver addresses the first event 204. In a specific example of this particular embodiment, the treatment parameter may be
30 related to the volume of an infusion of a medicament, such as a fluid, to a patient. The first event 204 may be defined in terms of a predetermined volume level value or in terms of units of time remaining until a predetermined volume level value is reached during treatment of the

patient by infusion. When the first event 204 occurs and the first alarm state 208 is activated, the caregiver may activate the snooze feature 200, which deactivates the first alarm state 208. In this example, activation of the snooze feature 200 will define or enable the second event 202 in terms of a second volume level value or increment, or in terms of units of time until a volume level value is reached during the treatment of the patient. When the particular value associated with the second event 202 is reached, the second alarm state 206 is activated. The snooze feature 200 may be configured such that additional events 210 may be thereafter defined by further activation of the snooze feature 200. The second alarm state 206, or one or more additional alarm states 212, may be associated with these additional events 210. When the treatment parameter is related to the volume in an infusion application, the events can act as notifications to the caregiver that a particular point in the infusion treatment has been reached. Notification before the end of an infusion, i.e. a "near-end" alert, provides the caregiver the opportunity to avoid interruption in therapy, unwanted changes in the rate of infusion, or other occurrences that may adversely affect treatment of the patient. To avoid such occurrences, the caregiver can use the time after notification and before the end of the infusion to prepare and set-up a new container or infusion kit.

In a particular embodiment, the alarm system 52 is in communication with a computer network 220 of a healthcare facility to allow communication with other devices or systems 222 within the facility. In such an embodiment, for example, a pharmacy of the facility can be automatically notified of one or more of the events so that a new container of fluid or drug can be prepared in time to avoid an interruption in the infusion therapy of the patient. The alarm system 52 can also be in direct communication, including wireless communication, with a device or system 224 to allow for various control options of the system or alarm state duplication or notification within the device or system 224. In addition, the alarm system 52 can be utilized for infusion of medicaments contained in flexible bags, syringes or semi-rigid containers. It is further understood that the alarm system 52 can occur on an infusion device such as an infusion pump shown in the Figures, but also on a handheld device, a nurse paging system or a central monitoring system.

It should be appreciated that the snooze feature 200 can be implemented in numerous applications in accordance with the principles of the present invention, and as disclosed in the configurations shown in FIGS. 1-5 and 8. For purposes of exemplification of a particular application of this feature and/or one or more other aspects of the present invention, the

following example is provided and certain aspects thereof are schematically illustrated in FIG. 7. It should be understood that this example is one of many possible applications of the principles of the present invention and should in no way be construed to limit the scope of the present invention to the details of this particular example.

5

EXAMPLE

In this particular example, a customizable "near-end" alarm system 250 having a snooze feature 252 is provided for use in connection with an infusion pump used to deliver a medicament or fluid to a patient via infusion. The alarm system 250 is associated with the pump and can be incorporated into the pump, or a separate device or system, such as a personal digital assistant (PDA) or other portable computing device, a paging system, monitoring system, or other device, network, or system. The near-end alarm system 250 can be customizable to a specific drug infusion wherein the snooze feature 252 allows for notification to the caregiver before the end of the infusion. The notification is in the form of a first and/or a second alarm state 254 and 256 of the alarm system 250, which can be audible, visual, or both. In this example, the alarm states 254 and 256 notify the caregiver that the infusion volume remaining will soon reach a predetermined value (which is zero in this case, although other values are possible) so that the caregiver can respond to the notification, such as by hanging a new fluid container and resetting the volume to be infused via the pump. This prevents the infusion from dropping to a lower rate that could potentially adversely affect the patient's hemodynamic status.

10
15
20

In this example, a first event 260 is defined by the infusion volume reaching a first value or parameter X, which can be preprogrammed; programmed at the point of care for a specific drug infusion such as at the bedside; obtained via an identification or data associated with a line set or container, such as a barcode label, RFID, or the like; obtained from an external device, such as a handheld device or other external device; or obtained from an external source via a network connection; or the like. Alternatively, the first event 260 can be defined by a value or parameter representing an amount of time remaining before the end of the infusion (for example, the number of minutes remaining before the end of the infusion). The value associated with the first event 260 can be a component of a predetermined drug specific profile associated with a container of a specific drug or line set type. A second event 262 is also defined by the infusion volume reaching a second value or parameter Y, which can

25

30

be programmed or obtained in similar fashion to that of the first value X. If desired, additional events defined by respective values may also be programmed.

When the first value X is reached during infusion, the first alarm state 254 is activated, thereby notifying the caregiver. The first value X could represent 30 minutes remaining
5 before completion of the infusion. The caregiver can then activate the snooze feature. Activation of the snooze feature 252 of the alarm system 250 allows the second event 262 to be set within the system so that upon occurrence of the second event 254, i.e., the infusion volume reaching the second value Y, the second alarm state 262 is activated to further notify the caregiver. In a preferred embodiment, the second alarm state 262 is discernable from the
10 first alarm state 260 to ensure that the caregiver will be notified of the second event 254, especially in critical applications. If additional events have been programmed, the snooze process can be continued for each of the additional events. In a particular embodiment with only two programmed events, the first alarm state 252 and/or the second alarm state 254 comprises an escalating alarm that escalates as the volume value (or time value) decreases
15 from the second value to notify the caregiver of the rate of decreasing volume (or time). Depending on the type of alarm, the escalation could be in the form of an increase in volume, a change in the type of tone, a change in the interval or frequency of the tone, the activation of, or a change in appearance of, one or more visual indicators, or any combination thereof. This escalation process can also be incorporated in embodiments having more than two events
20 and associated alarm states. The alarm system 52 could have a more urgent (using any of the discernable alerts described above) near-end alert/alarm for a designated high alert or in critical infusion therapies.

In a particular embodiment, the alarm system 250 is in communication with a computer network 270 of the healthcare facility to allow communication with other systems
25 272 within the facility. In such an embodiment, for example, a pharmacy of the facility can be automatically notified of one or more of the events so that a new container of fluid or drug can be prepared in time to avoid an interruption in the infusion therapy of the patient.

With such features of the alarm system 52, a clinician is alerted that a volume to be infused will soon be zero so the clinician can respond to the alert, set up a new container and
30 reset the volume to be infused. This prevents an infusion from dropping to an unwanted or undesirable lower rate and also prevents an interruption of therapy. The delay or snooze feature is completely customizable wherein the alarm system 52 can be configured as desired.

FIG. 8 shows another embodiment of an alarm system of the present invention, generally designated with the reference numeral 352. The alarm system 352 is similar to the embodiments described above, however, the alarm system 352 is utilized with a disposable element or micro electro-mechanical system (MEMS) element. In one preferred embodiment, the MEMS element is a MEMS pump. It is understood, however, that the pump could be any type of disposable pump including pumps micro-molded in plastic or otherwise manufactured on a small scale. As shown in FIG. 6, alarm system 352 may be used in conjunction with a medication delivery system, generally designated with the reference numeral 300. The system 100 generally includes a medical device 312, preferably a MEMS pump 312, which may have an associated controller 330, an administration line set 314, a container 316. The system 100 may also take the form of any of the systems such as disclosed in commonly-owned U.S. Patent Application Number 10/040,887, entitled "Infusion System," which application is expressly incorporated by reference herein.

The container 316 is a container similar to the container 16 described above. In one preferred embodiment, the container 316 is a flexible bag adapted to contain a medication such as a medicament or medical fluid. The administration line set 314 is similar the line set 14 described above. The line set 314 includes a tubing having one end connected to or otherwise in communication with the container 316 and another end having a catheter or other device for communication with the patient.

As further shown in FIG. 5, the MEMS pump 312 is operably associated with the line set 314. The MEMS pump 312 may be connected to the line set 314 in various configurations. For example, the MEMS pump 312 may have an inlet port 320 and an outlet port 322 wherein the MEMS pump 312 is connected at an intermediate portion of the line set 314. Accordingly, a portion of the line set 314 is connected to the inlet port and a portion of the line set 314 is connected to the outlet port 322 wherein the MEMS pump 312 is operably connected to the line set 314. Once properly connected, the MEMS pump 312 can pump fluid from the container 316 to the patient.

As discussed, the pump 312 may be a MEMS pump 312. MEMS devices are typically etched in silicon. It is further understood that MEMS may also describe other types of micro electromechanical system devices such as devices that are micro-molded in plastic. Thus, MEMS devices may include devices etched in silicon, molded in plastic or otherwise fabricated on a small scale.

As discussed, the system 300 may further use the controller 330. The controller 330 is operably associated with the MEMS pump 312. The controller 330 may communicate with the MEMS pump 312 via a wireless connection. Alternatively, a hard connection may be utilized wherein the MEMS pump 312 may be plugged into the controller 330. While the controller 330 is shown as a separate component in one preferred embodiment, it is understood that the controller 330 may be integral with the MEMS pump 312.

Similar to the discussion above, the controller 330 incorporates the alarm system 352. The alarm system 352 operates with the controller 330 and in cooperation with the MEMS pump 312. It is further understood that the alarm system 352 could be integral with the pump 312. The alarm system 352 is customizable and may include all of the features of the alarm systems previously described. Thus, as described, the alarm system 352 may include multiple alarm states that are discernable from one another. The alarm system 352 may also include the near-end alert/alarm feature as discussed above.

It is further understood that a pump utilized in the present invention will incorporate safety software. The safety software is capable of generating basic failure alarms wherein the pump would assume a fail safe condition such as no free flow of medicament through the pump. Various software/pump configurations may be utilized. For example, all software may be located on the pump head, or all software may be located off of, or remote from the pump head. In addition, all software may be located off of the pump head with the exception of the specific safety software being located on the pump head.

It should be understood that the invention may be embodied in other specific forms without departing from the scope of the claims. The present embodiments, therefore, are to be considered in all respects illustrative and not restrictive, and the invention is not to be limited to the details given herein.

What is claimed is:

1. An alarm system for a medical pump associated with delivering a medicament to a patient, the alarm system comprising an alarm associated with at least one treatment parameter, the alarm having a first alarm state associated with a first event relating to the at least one treatment parameter, and a second alarm state associated with a second event, the second alarm state discernable from the first alarm state, and wherein the second event is defined by expiration of an amount of time measured from occurrence of the first event.
2. The alarm system of claim 1, wherein the second event relates to the at least one treatment parameter.
3. The alarm system of claim 1 or 2, wherein the second alarm state is an escalation of a frequency associated with the first alarm state.
4. The alarm system of any one of claims 1 to 3, wherein the at least one treatment parameter is associated with the pump.
5. The alarm system of any one of claims 1 to 3, wherein the at least one treatment parameter is associated with a source external to the pump.
6. The alarm system of any one of claims 1 to 5, wherein an alarm signal associated with the alarm states is routed to a device external to the pump.
7. The alarm system of any one of claims 1 to 6, wherein the alarm is audible.
8. The alarm system of claim 7, wherein the second alarm state has a volume level that is discernable from the first alarm state.
9. The alarm system of claim 7, wherein the second alarm state has a tone that is discernable from the first alarm state.
10. The alarm system of claim 1 or 2, wherein the alarm is visual.

11. The alarm system of claim 10, wherein the second alarm state has an appearance that is discernable from the first alarm state.
12. The alarm system of claim 1 or 2, wherein the alarm has an audible component and a visual component.
13. The alarm system of claim 1, wherein the second event is associated with a life-threatening situation for the patient.
14. The alarm system of any one of claims 1 to 13, wherein the pump is adapted to shut off when the alarm is in the second alarm state.
15. The alarm system of any one of claims 1 to 14, wherein the events can be set by a user.
16. The alarm system of claim 1, wherein the second alarm state is only operational with a particular medicament.
17. The alarm system of claim 16, wherein identification of the particular medicament is adapted to be stored in a memory associated with the pump.
18. An alarm system for a medical pump associated with delivering a medicament to a patient, the alarm system comprising an alarm associated with at least one treatment parameter, the alarm having a first alarm state associated with a first event relating to the at least one treatment parameter, and a second alarm state associated with a second event relating to the at least one treatment parameter, the second alarm state discernable from the first alarm state, and wherein the second event is associated with a life-threatening situation for the patient.
19. The alarm system of claim 18 wherein the alarm is perceptible to an operator.
20. The alarm system of claim 18 or 19, wherein the at least one treatment parameter is associated with a source external to the pump.

21. The alarm of any one of claims 18 to 20, wherein an alarm signal associated with the alarm states is routed to a device external to the pump.
22. An alarm system for a medical pump for delivering a therapeutic fluid to a patient, the alarm system comprising an alarm associated with at least one operating parameter, the alarm having a first alarm state and a second alarm state, the first alarm state indicating a non-critical deviation from an original value of the at least one operating parameter, the second alarm state discernable from the first alarm state and indicating a critical deviation from the original value of the at least one operating parameter.
23. An alarm system for a medical pump associated with delivering a fluid to a patient in connection with treatment of the patient, the alarm system comprising:
an alarm associated with at least one treatment parameter, the alarm having a first alarm state associated with a first event relating to the at least one treatment parameter, and a second alarm state associated with a second event relating to the at least one treatment parameter, the second alarm state discernable from the first alarm state; and
a snooze element that, when activated, enables the second alarm state to be activated upon occurrence of the second event.
24. The alarm system of claim 23, wherein the second event is preprogrammed into a memory of the system.
25. The alarm system of claim 23, wherein the second event is programmed into a memory of the system at a point of care of the patient.
26. The alarm system of any one of claims 23 to 25, the alarm further including a third alarm state associated with a third event.
27. The alarm system of any one of claims 23 to 26, wherein the second event is a value associated with the treatment parameter.
28. The alarm system of claim 27, wherein the value is a unit of time.
29. The alarm system of claim 27, wherein one of the first and second alarm states comprises an escalating alarm that escalates relative to a change in the treatment parameter.

30. The alarm system of claim 27, wherein the value is related to a volume parameter of the fluid.

31. The alarm of claim 27, wherein the value is a unit of time remaining until a predetermined volume level of fluid is reached during operation of the pump.

32. An alarm system for a medical device used in connection with treatment of a patient, the alarm system comprising:

an alarm associated with at least one treatment parameter, the alarm having a first alarm state associated with a first event relating to the at least one treatment parameter, and a second alarm state associated with a second event relating to the at least one treatment parameter, the second alarm state discernable from the first alarm state; and

a snooze element that, when activated, enables the second alarm state to be activated upon occurrence of the second event.

33. A pump assembly associated with delivering a medicament to a patient, the pump assembly comprising a micro electro-mechanical system (MEMS) pump having an alarm system having an alarm associated with at least one treatment parameter, the alarm having a first alarm state associated with a first event relating to the at least one treatment parameter, and a second alarm state associated with a second event, the second alarm state discernable from the first alarm state, and wherein the second event is defined by expiration of an amount of time measured from occurrence of the first event.

34. The pump assembly of claim 33 wherein the MEMS pump has a controller and the alarm system resides in the controller, the controller communicating with the MEMS pump via a wireless connection.

35. A pump assembly associated with delivery of a medicament to a patient, the pump assembly comprising:

a micro electro-mechanical system (MEMS) pump having an alarm system having an alarm associated with at least one treatment parameter, the alarm having a first alarm state associated with a first event relating to the at least one treatment parameter, and a second alarm state associated with a second event relating to the at least one treatment parameter, the second alarm state discernable from the first alarm state; and

a snooze element that, when activated, enables the second alarm state to be activated upon occurrence of the second event.

FIG. 1

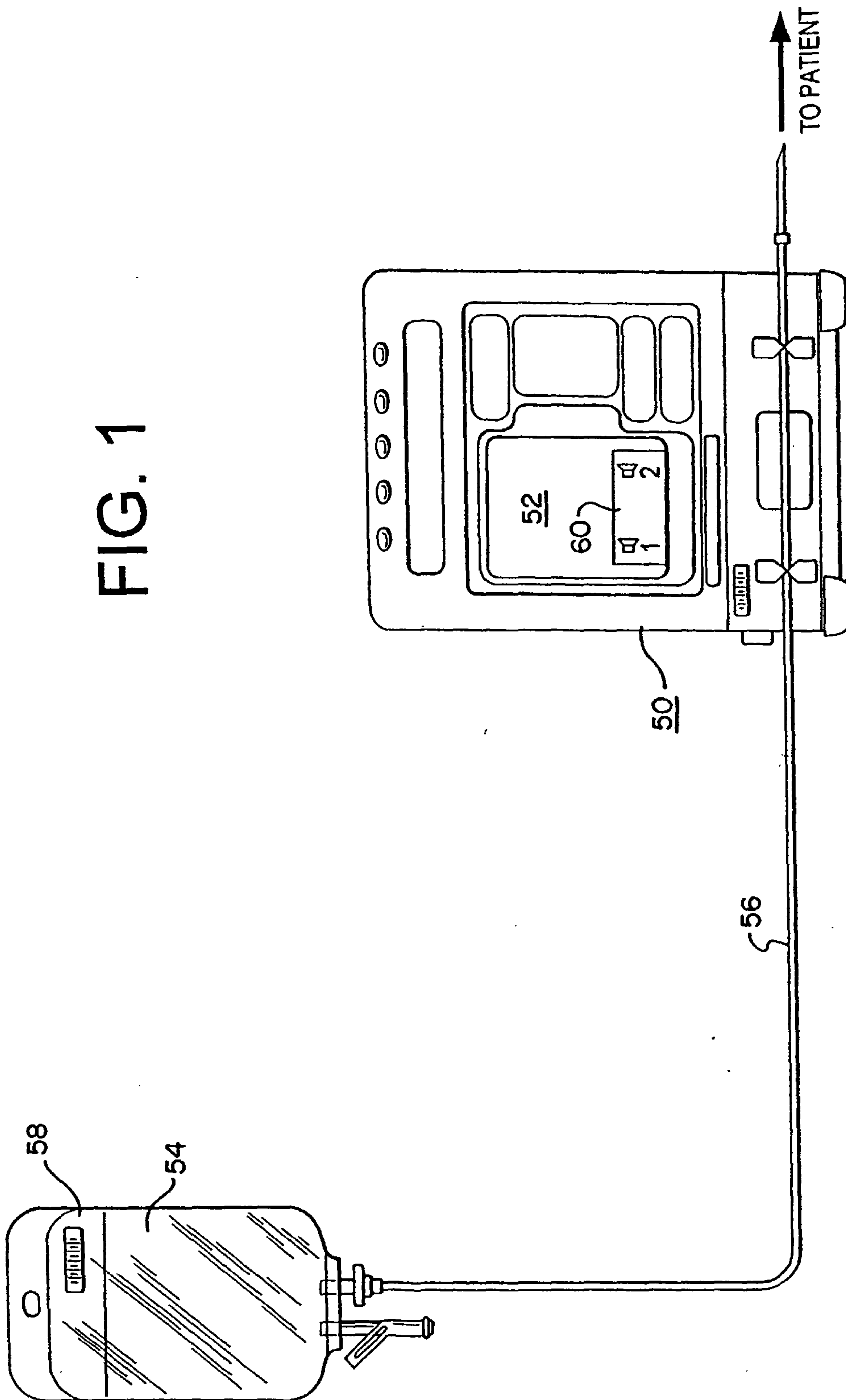

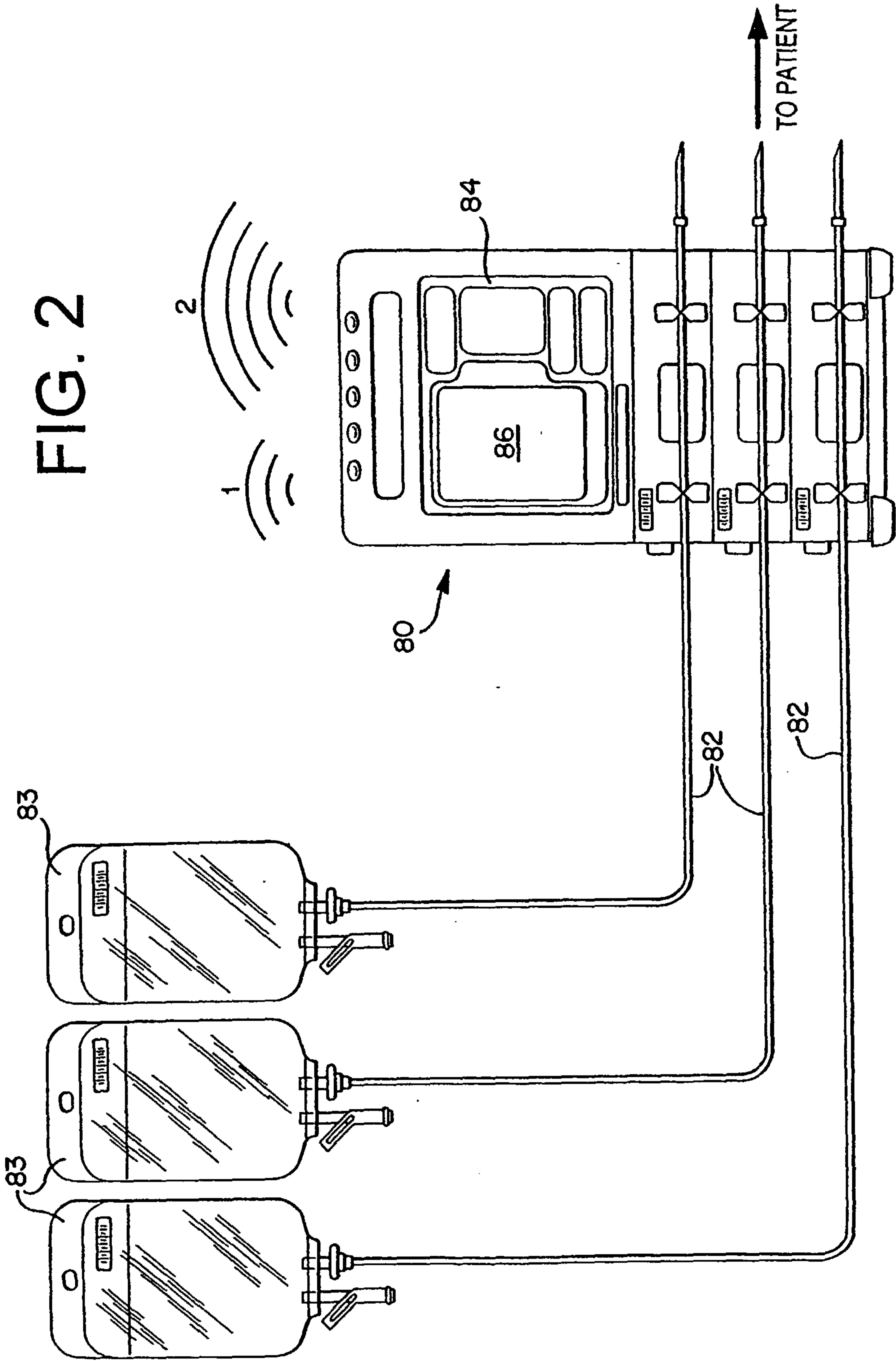

3/7

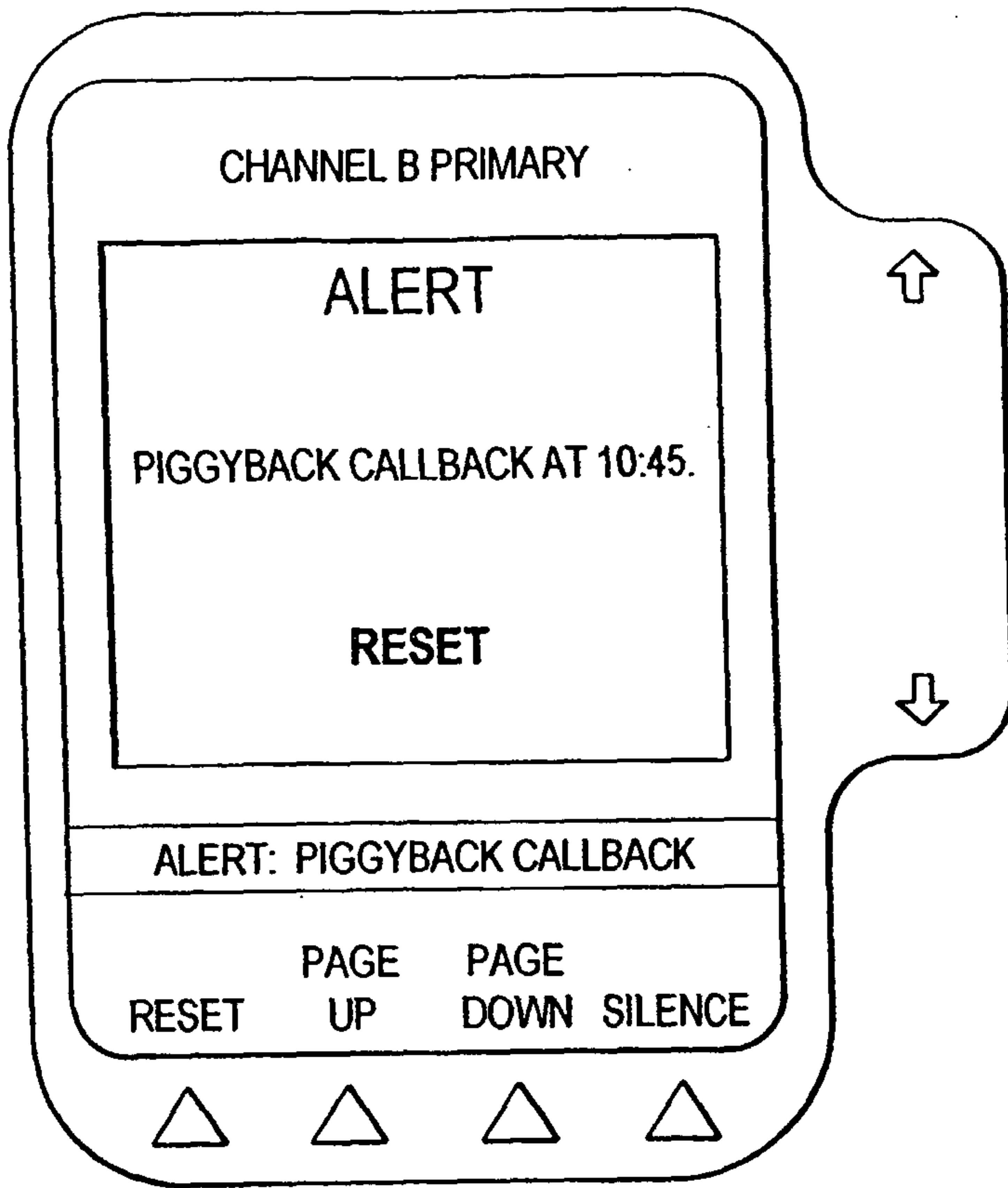

FIG. 3

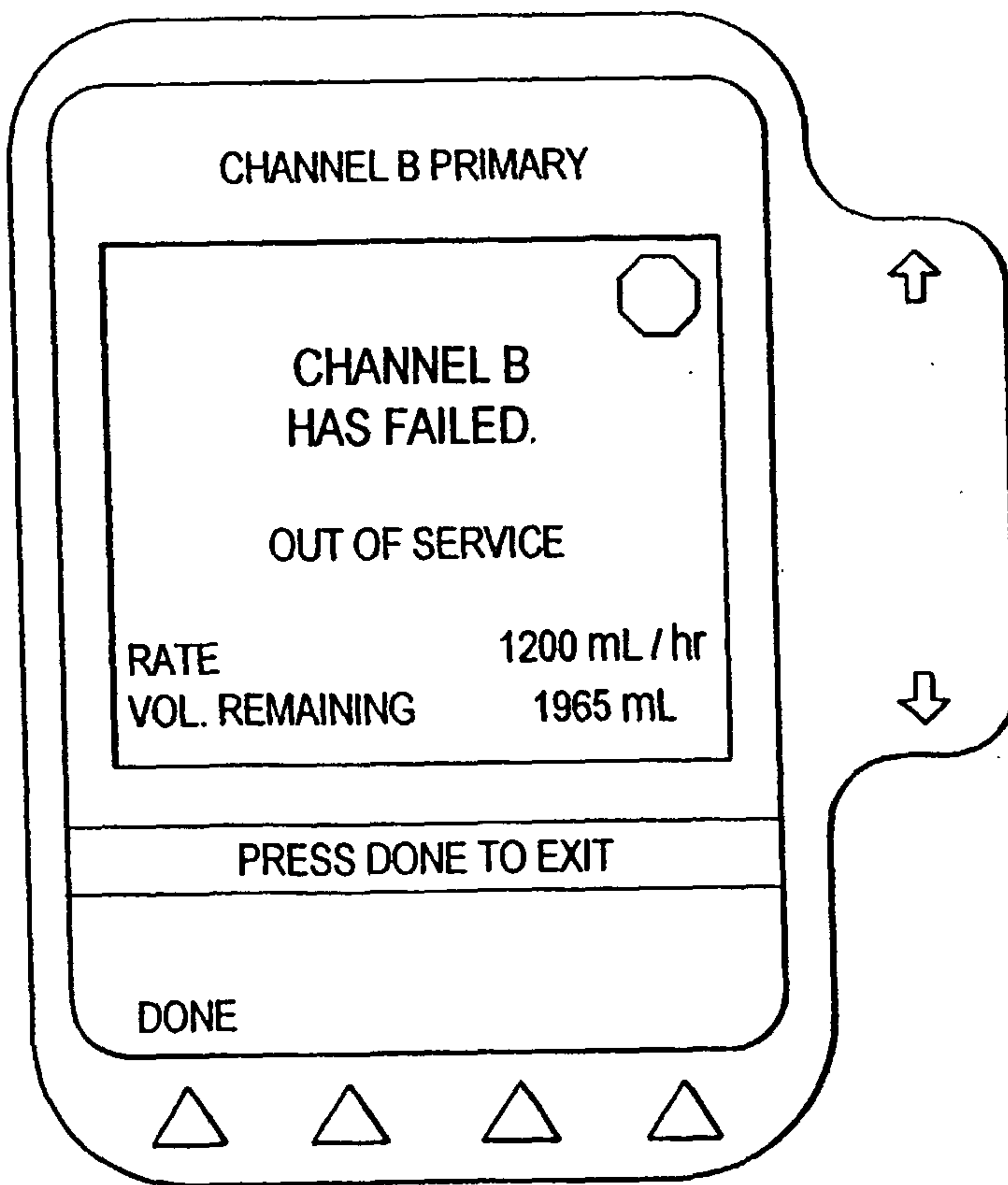

FIG. 4

4/7

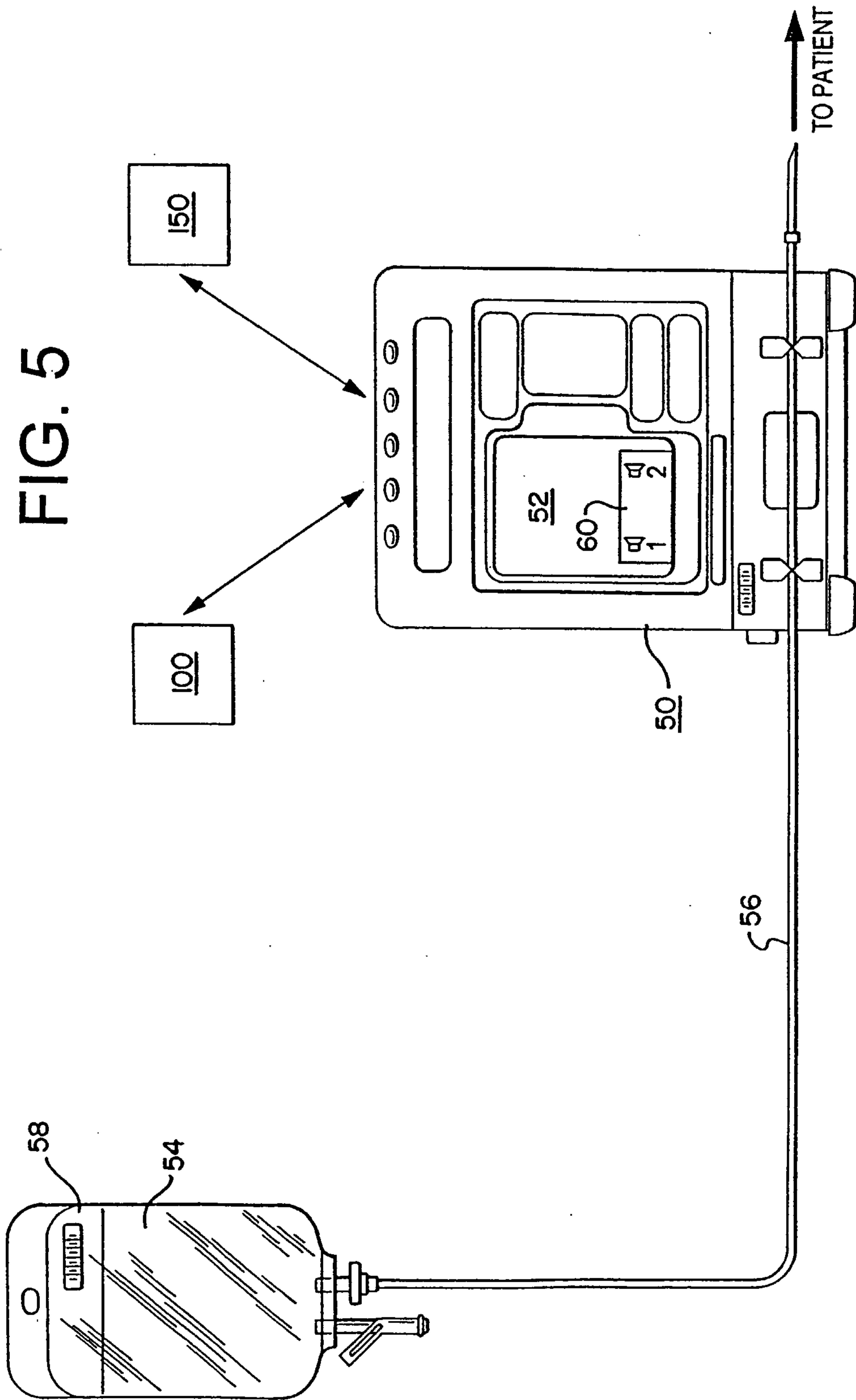
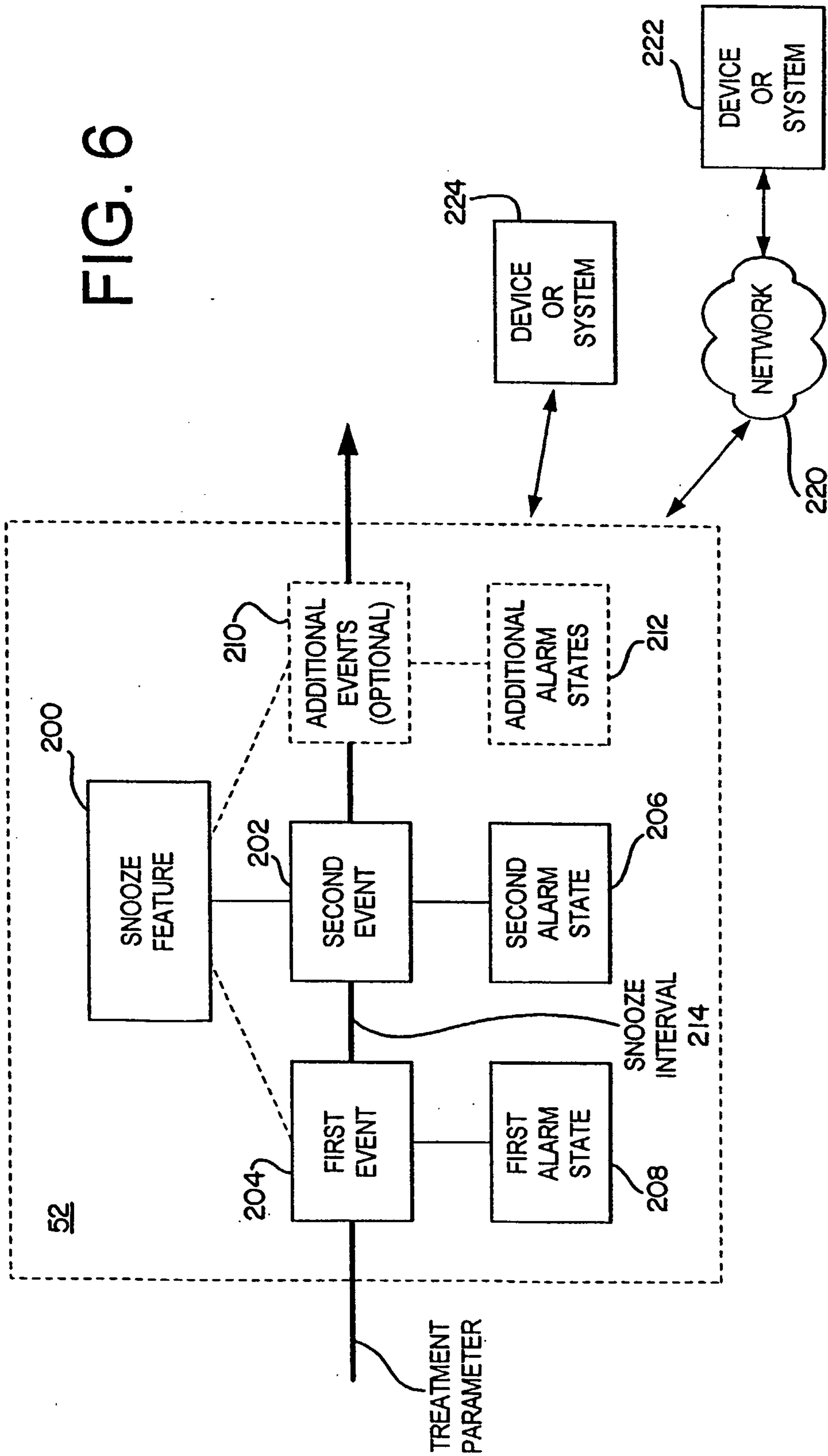

FIG. 6



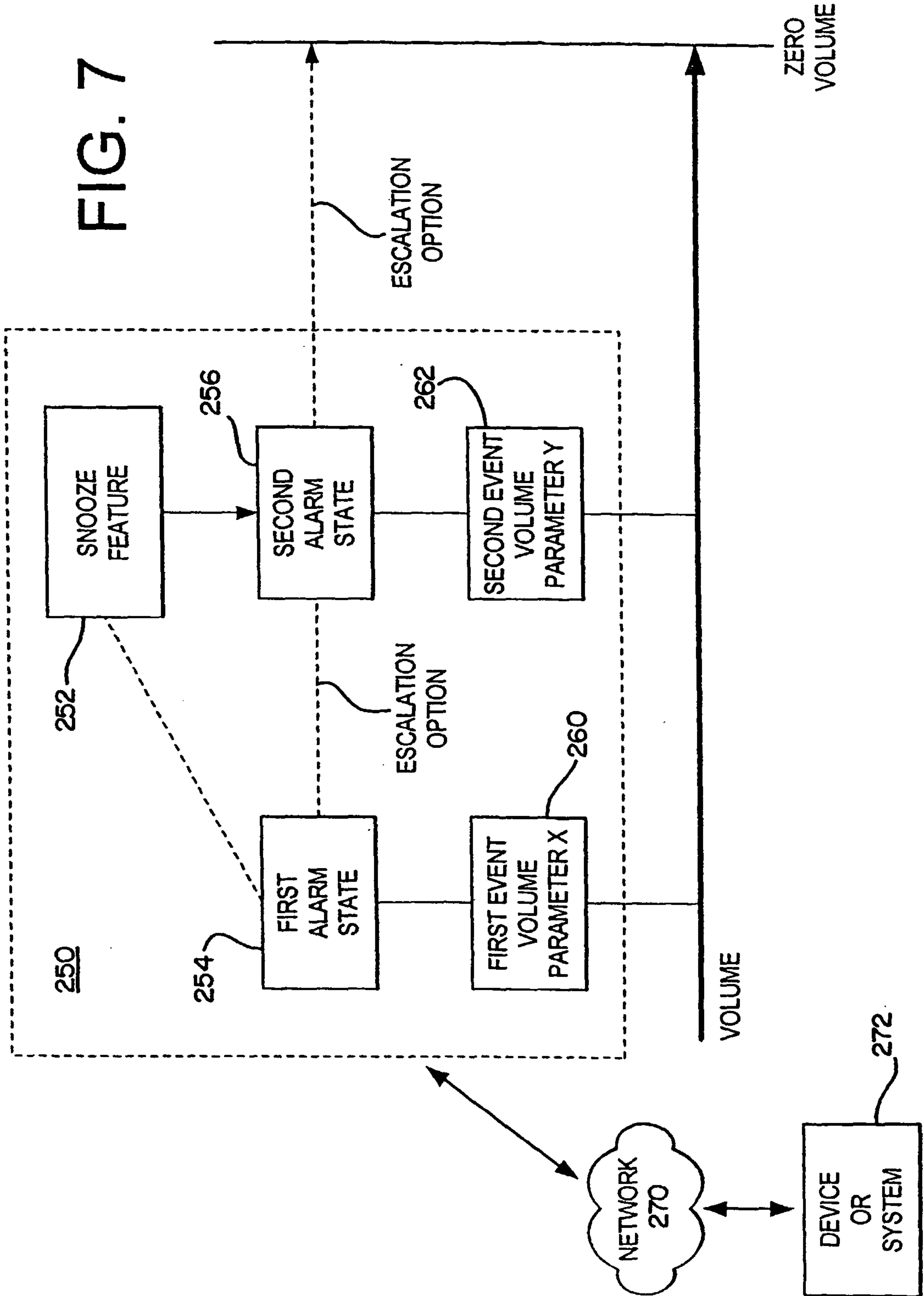

FIG. 8

