

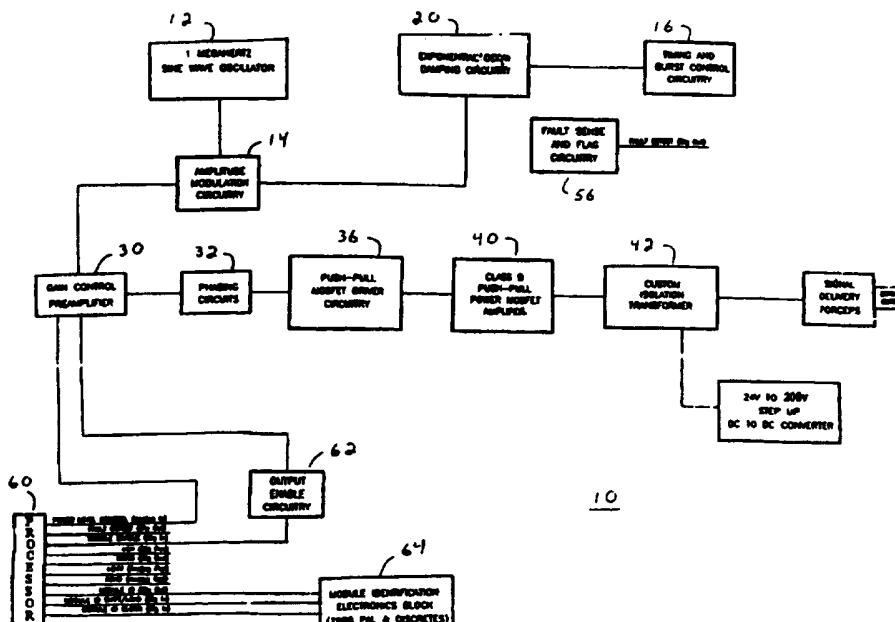

INTERNATIONAL APPLICATION PUBLISHED UNDER THE PATENT COOPERATION TREATY (PCT)

<p>(51) International Patent Classification <sup>6</sup> : <b>A61B 17/39</b></p>	<p><b>A1</b></p>	<p>(11) International Publication Number: <b>WO 96/14021</b> (43) International Publication Date: 17 May 1996 (17.05.96)</p>
<p>(21) International Application Number: PCT/US95/13858 (22) International Filing Date: 27 October 1995 (27.10.95) (30) Priority Data: 08/330,921 28 October 1994 (28.10.94) US 08/465,447 5 June 1995 (05.06.95) US (71) Applicant (for all designated States except US): CHIRON VISION CORPORATION [US/US]; 500 Iolab Drive, Claremont, CA 91711 (US). (72) Inventors; and (75) Inventors/Applicants (for US only): WALSH, Daniel, F., Jr. [-/US]; 100 Madison Court, North Wales, PA 19454 (US). KEATING, Michael, J. [-/US]; 151 Millbrock Road, Blairstown, NJ 07825 (US). (74) Agents: RITTMASER, Ted, R. et al.; Loeb and Loeb, 1880 Century Park East, Los Angeles, CA 90067 (US).</p>		<p>(81) Designated States: AL, AM, AT, AU, BB, BG, BR, BY, CA, CH, CN, CZ, DE, DK, EE, ES, FI, GB, GE, HU, IS, JP, KE, KG, KR, KZ, LK, LR, LS, LT, LU, LV, MD, MG, MK, MN, MW, MX, NO, NZ, PL, PT, RO, RU, SD, SE, SG, SI, SK, TJ, TM, TT, UA, UG, US, UZ, VN, European patent (AT, BE, CH, DE, DK, ES, FR, GB, GR, IE, IT, LU, MC, NL, PT, SE), OAPI patent (BF, BJ, CF, CG, CI, CM, GA, GN, ML, MR, NE, SN, TD, TG), ARIPO patent (KE, LS, MW, SD, SZ, UG).  <b>Published</b> <i>With international search report.</i> <i>Before the expiration of the time limit for amending the claims and to be republished in the event of the receipt of amendments.</i></p>

(54) Title: BIPOLAR ELECTROSURGICAL APPARATUS



(57) Abstract

An electrosurgical apparatus comprising a bipolar electrode, and means for generating uniform bursts of high frequency signals (12) having a periodic waveform. The apparatus further comprises means for impressing substantially identical decaying amplitude envelopes (20) on said uniform bursts, and means (30) for applying said impressed bursts to said electrode. Preferably, the periodic waveform is a sine wave form, and the decaying amplitude envelopes decay at a predetermined rate from a preselected initial amplitude. Also, preferably, each of the bursts of high frequency signals has a given time length, and successive bursts are separated by that same given time length.

**FOR THE PURPOSES OF INFORMATION ONLY**

Codes used to identify States party to the PCT on the front pages of pamphlets publishing international applications under the PCT.

AT	Austria	GB	United Kingdom	MR	Mauritania
AU	Australia	GE	Georgia	MW	Malawi
BB	Barbados	GN	Guinea	NE	Niger
BE	Belgium	GR	Greece	NL	Netherlands
BF	Burkina Faso	HU	Hungary	NO	Norway
BG	Bulgaria	IE	Ireland	NZ	New Zealand
BJ	Benin	IT	Italy	PL	Poland
BR	Brazil	JP	Japan	PT	Portugal
BY	Belarus	KE	Kenya	RO	Romania
CA	Canada	KG	Kyrgystan	RU	Russian Federation
CF	Central African Republic	KP	Democratic People's Republic of Korea	SD	Sudan
CG	Congo	KR	Republic of Korea	SE	Sweden
CH	Switzerland	KZ	Kazakhstan	SI	Slovenia
CI	Côte d'Ivoire	LI	Liechtenstein	SK	Slovakia
CM	Cameroon	LU	Luxembourg	SN	Senegal
CN	China	LK	Sri Lanka	TD	Chad
CS	Czechoslovakia	LV	Latvia	TG	Togo
CZ	Czech Republic	MC	Monaco	TJ	Tajikistan
DE	Germany	MD	Republic of Moldova	TT	Trinidad and Tobago
DK	Denmark	MG	Madagascar	UA	Ukraine
ES	Spain	ML	Mali	US	United States of America
FI	Finland	MN	Mongolia	UZ	Uzbekistan
FR	France			VN	Viet Nam
GA	Gabon				

BIPOLAR ELECTROSURGICAL APPARATUS

1

BACKGROUND OF THE INVENTION

5 This invention generally relates to bipolar electro-surgical apparatus, and more specifically, to a bipolar cauterizer well suited for use during microsurgery such as micro ophthalmic surgery.

10 Microsurgical procedures are gaining ever-increasing acceptance in the surgical community for performing precise, minimum invasive surgery for various parts of the body, and one particularly widespread microsurgical application is in the field of ophthalmology. In this application, commonly, a hand  
15 piece having a small tool is used either to cut or to mascerate the eye tissue while an irrigation or infusion liquid is brought to the surgery site. The cut or mascerated tissue is carried away from the surgical site by a suction conduit or tube to a collection vessel such as a bag or bottle. A cauterizer may be used to help  
20 control bleeding at the surgical site.

Consoles are specifically designed for these ophthalmic procedures. These consoles are used to operate the tools and the suction and infusion lines  
25 used in the procedures, and to generate the light that is used to illuminate the surgical site. Typically, these consoles have a modular design and include a multitude of separable or removable modules, with each module being used to operate or to perform a specific  
30 task. For example, one module may be employed to operate the hand piece used to cut or mascerate the eye

35

-2-

1 tissue, another module may be used to infuse and  
aspirate the surgical site, and a third module may be  
used to operate the cauterizer.

5 SUMMARY OF THE INVENTION

An object of this invention is to improve  
bipolar cauterizers.

10 Another object of this invention is to apply a  
damped sinusoidal wave form power signal to a bipolar  
cauterizer.

15 These and other objectives are attained with  
an electrosurgical apparatus comprising a bipolar  
electrode, and means for generating uniform bursts of  
high frequency signals having a periodic waveform. The  
apparatus further comprises means for impressing  
substantially identical decaying amplitude envelopes on  
said uniform bursts, and means for applying said  
impressed bursts to said electrode.

20 Preferably, the decaying amplitude envelopes  
decay at a predetermined rate from a preselected initial  
amplitude. Also, preferably, the periodic waveform is a  
sine wave form. Each of the bursts of high frequency  
signals has a given time length, and successive bursts  
25 are separated by that same given time length.

30 Further benefits and advantages of the  
invention will become apparent from a consideration of  
the following detailed description given with reference  
to the accompanying drawings, which specify and show  
preferred embodiments of the invention.

35

1 BRIEF DESCRIPTION OF THE DRAWINGS

Figure 1 is a block diagram illustrating an operating system for a bipolar coagulator.

5 Figures 2, 3 and 4 illustrate details of the blocks shown in Figure 1.

Figure 5 shows a portion of the output signal generated by an exponential decay circuit of the operating system of Figures 1-4.

10 Figure 6 shows a portion of a damped sine wave signal generated by the system of Figure 1.

DETAILED DESCRIPTION OF THE PREFERRED EMBODIMENTS

15 With reference to Figures 1-4, in system 10, a 1 megahertz sine wave oscillator 12 couples its output to an amplitude modulator circuitry (MC1495C) 14. The oscillator 12 generates a 1 megahertz sine wave of constant amplitude.

20 A timing control circuit 16, comprised of a timing circuit (LM556N) 20 generates an output pulse every 64 micro-seconds. This output pulse is applied to exponential decay damping circuit 20. In particular, the output pulse from circuit 16 operates a switch (SW201) 22, which discharges capacitor C6 of an RC  
25 circuit 24, comprised of capacitor C6 and resistor R6, every 64 microseconds. The RC timing circuit 24 is coupled through (U5A) to pin 4 of amplitude modulation circuit 14 to apply a decaying signal, a portion of which is shown in Figure 5. In the preferred  
30 embodiment, this signal has a maximum amplitude at 64

-4-

1     microsecond intervals and decays to zero amplitude in  
less than 64 microseconds.

5             The decaying signal modulates the 1 megahertz  
sine wave signal at amplitude modulation circuitry 14,  
to generate a damped sine wave signal, as represented in  
Figure 6. This damped sine wave signal is initiated at  
a constant periodicity of 64 microseconds and is applied  
to gain control preamplifier 30, which may be used to  
adjust the amplitude of the signal. From preamplifier  
10 30, the signal is applied to phasing circuits (U12 and  
U13) 32, which convert the input signal into a pair of  
output signals 180° out of phase with one another.

15             These two output signals are applied to a gain  
control circuit (AD539) 34, which controls the amplitude  
of the phase signals. The phase signals are then  
applied, through push-pull driver circuits 36, to the  
inputs of class B push-pull power MOSFETs 40. The  
outputs of the push-pull class B amplifiers are coupled  
to the primary winding of transformer 42; and the output  
20 of the transformer 42 is coupled, via connector 44, to  
the bipolar electrode forceps, which may be a  
conventional bipolar coagulator.

25             Block 46 represents a power supply for  
transformer 42; and, for example, this power supply may  
be a 24V to 200V step up DC to DC converter.

30             The duty cycle of the system 10 is controlled  
by second timer circuit (LM556) 50. The duty cycle  
output of this circuit 50 is coupled to one input of  
gate (U19C) 52, which grounds the power level control  
input by means of switch (SW201) 54. Preferably, the  
duty cycle is one second on, one second off--that is,

35

-5-

1 the power signal is applied to the forceps for one  
second, with successive applications of the power signal  
being one second apart.

5 As represented in Figure 1, various parameters  
or operating conditions of system 10 may be sensed by  
appropriate fault detectors 56, which generate one or  
more signals that may represent those perimeters.

10 System 10 may be used for a variety of  
purposes and in a variety of specific application. For  
example, system 10 may be used during ophthalmic surgery  
to cauterize the surgical site. Even more specifically,  
system 10 is very well suited for use in a modular  
console that includes a multitude of other modules for  
operating other instruments or for performing other  
15 tasks related to ophthalmic surgery. For example,  
system 10 may be used in the console disclosed in  
co-filed PCT application no. \_\_\_\_\_ for which priority  
is based on U.S. s/n 08/330,926 (Attorney docket PD-4395),  
the disclosure of which is herein incorporated by reference.

20 In such an application system 10 or the  
console includes processor 60. The console processor,  
generally, may be used to control the overall operation  
of the console and to act as a communications interface  
between the console and the operator. Also, commands to  
25 activate or enable power system 10 may be generated by  
the console processor and transmitted to system 10 via  
enable circuit 62. Data transmitted in or by system 10  
may be transmitted to the console processor to keep that  
processor, and the console operator, informed of that  
30 data.

35

1           In Figure 1, block 64, represents an  
electronics module identification block, which is  
provided with an electronically readable serial number,  
identifying the power system.

5           While it is apparent that the invention herein  
disclosed is well calculated to fulfill the objects  
previously stated, it will be appreciated that numerous  
modifications and embodiments may be devised by those  
skilled in the art, and it is intended that the appended  
10 claims cover all such modifications and embodiments as  
fall within the true spirit and scope of the present  
invention.

15

20

25

30

35

1     CLAIMS

                  1.   Electrosurgical apparatus comprising:  
                  a bipolar electrode;  
5                   means for generating uniform bursts of a high  
frequency signal having a periodic waveform;  
                  means for impressing substantially identical  
decaying amplitude envelopes on said uniform bursts; and  
                  means for applying said impressed bursts to  
10                  said electrode.

                  2.   Apparatus according to Claim 1, wherein  
each of said envelopes has a predetermined rate of decay  
from a preselected initial amplitude.

                  3.   Apparatus according to Claim 2, wherein  
15                  said predetermined rate of decay is an exponential rate  
of decay.

                  4.   Apparatus according to Claim 1, wherein  
said periodic waveform is a sine wave form.

                  5.   Apparatus according to Claim 1, wherein  
20                  said periodic waveform has a frequency of approximately  
one megahertz.

                  6.   Apparatus according to Claim 1, wherein  
the generating means separates adjacent bursts.

                  7.   Apparatus according to Claim 1, wherein:  
25                  each of said bursts has a length equal to a  
given period of time; and  
                  successive bursts are separated by said given  
period of time.

                  8.   Apparatus according to Claim 7, wherein  
30                  said given period of time is approximately one second.

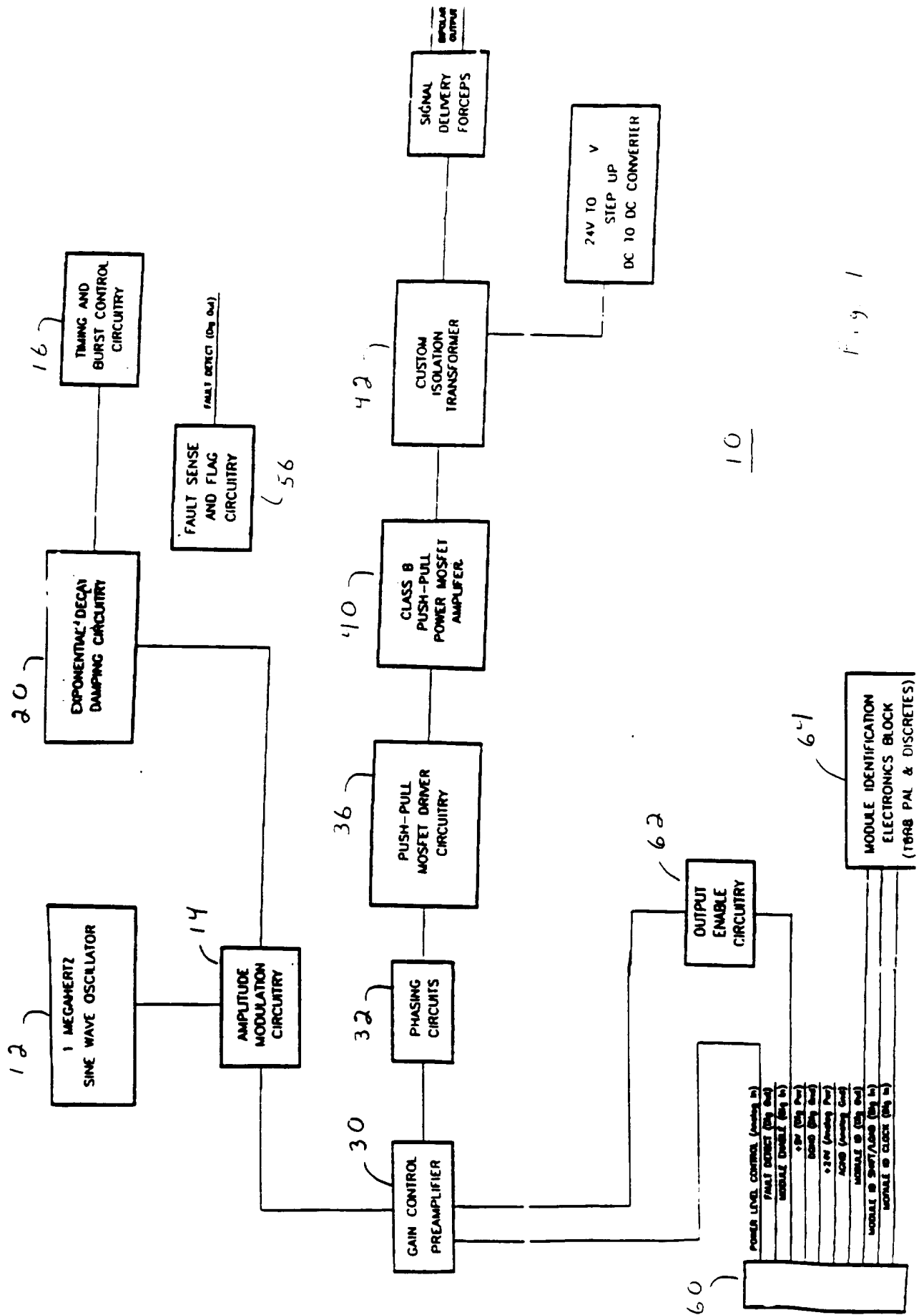
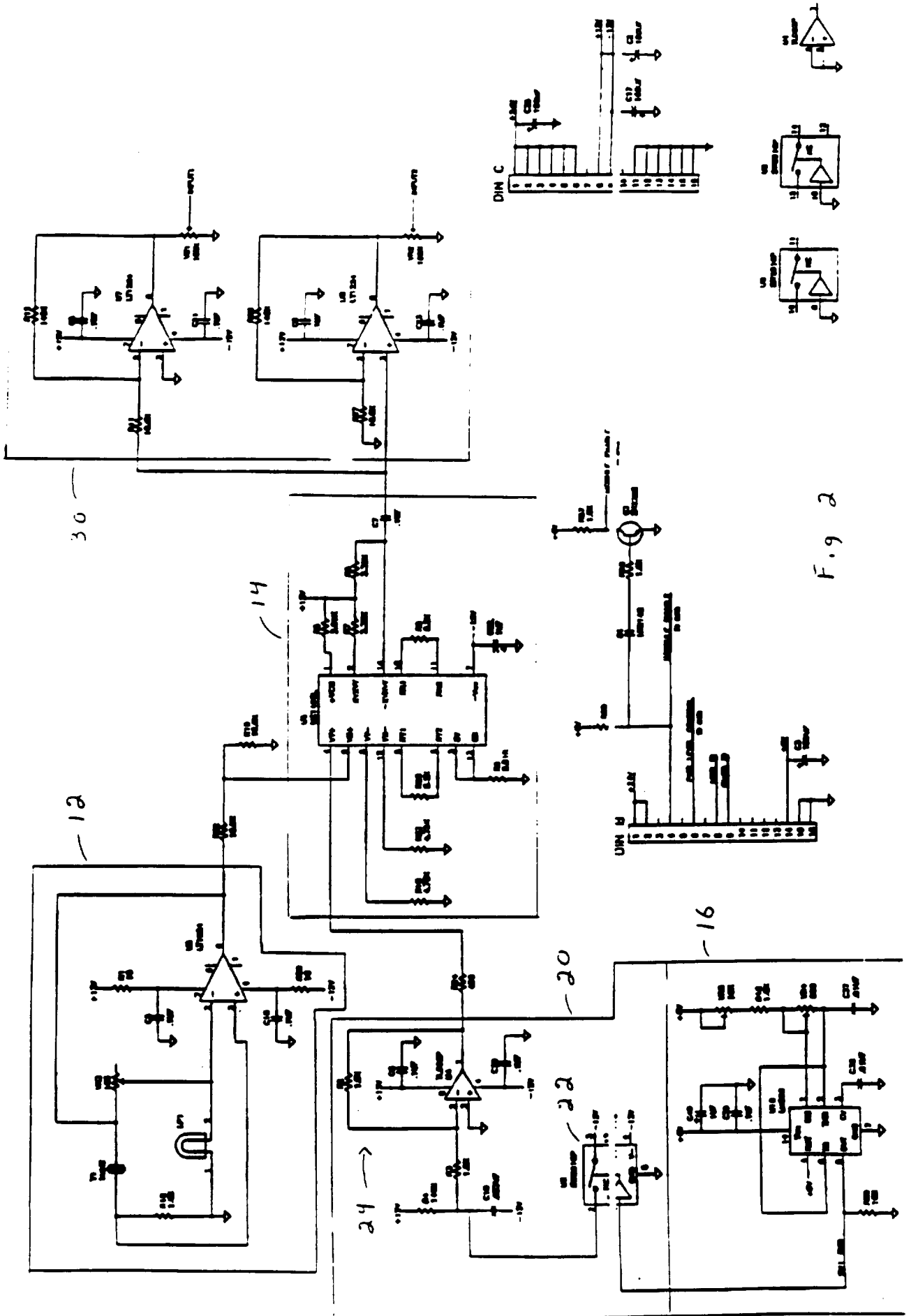
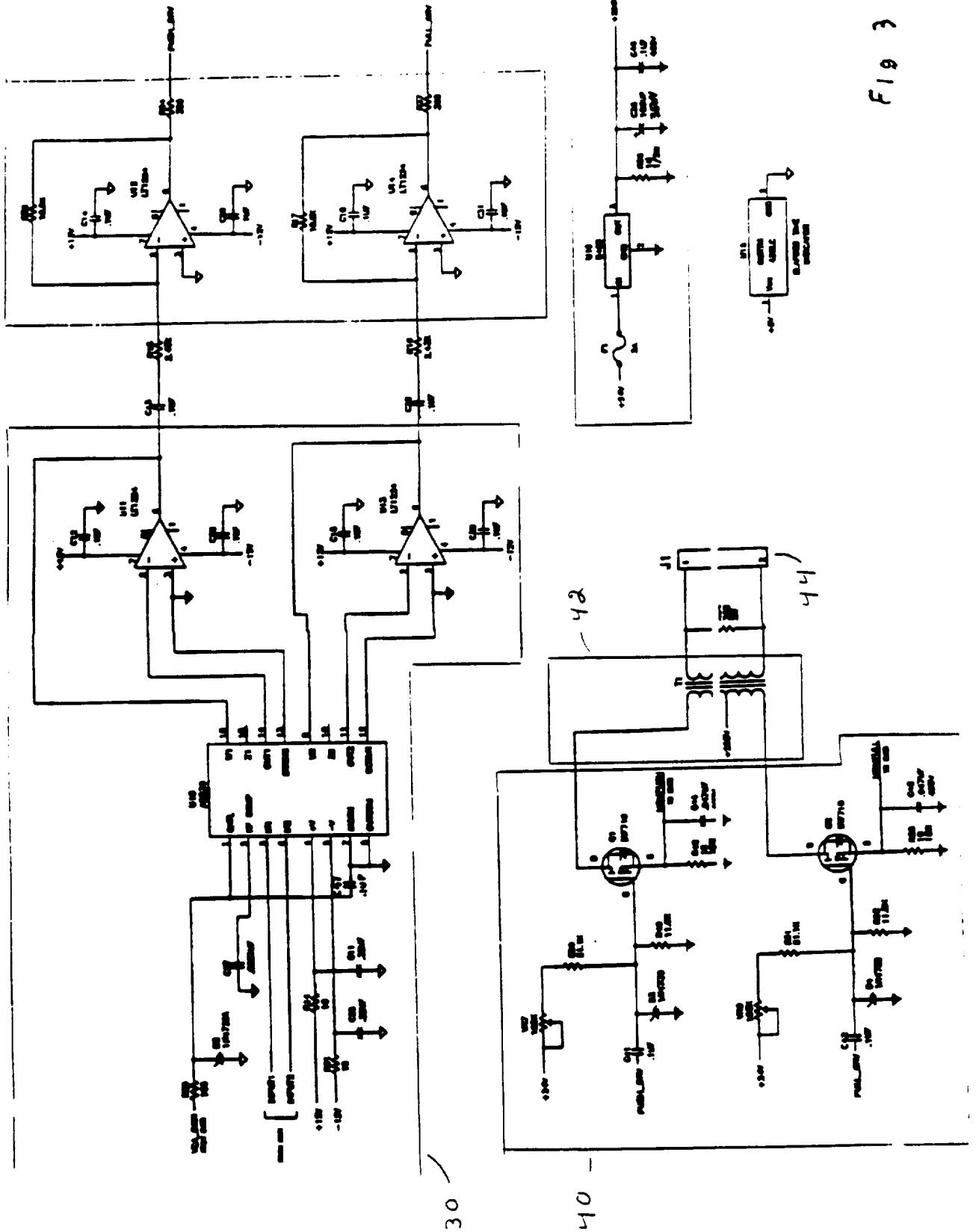

Fig 1

10



F.9 2



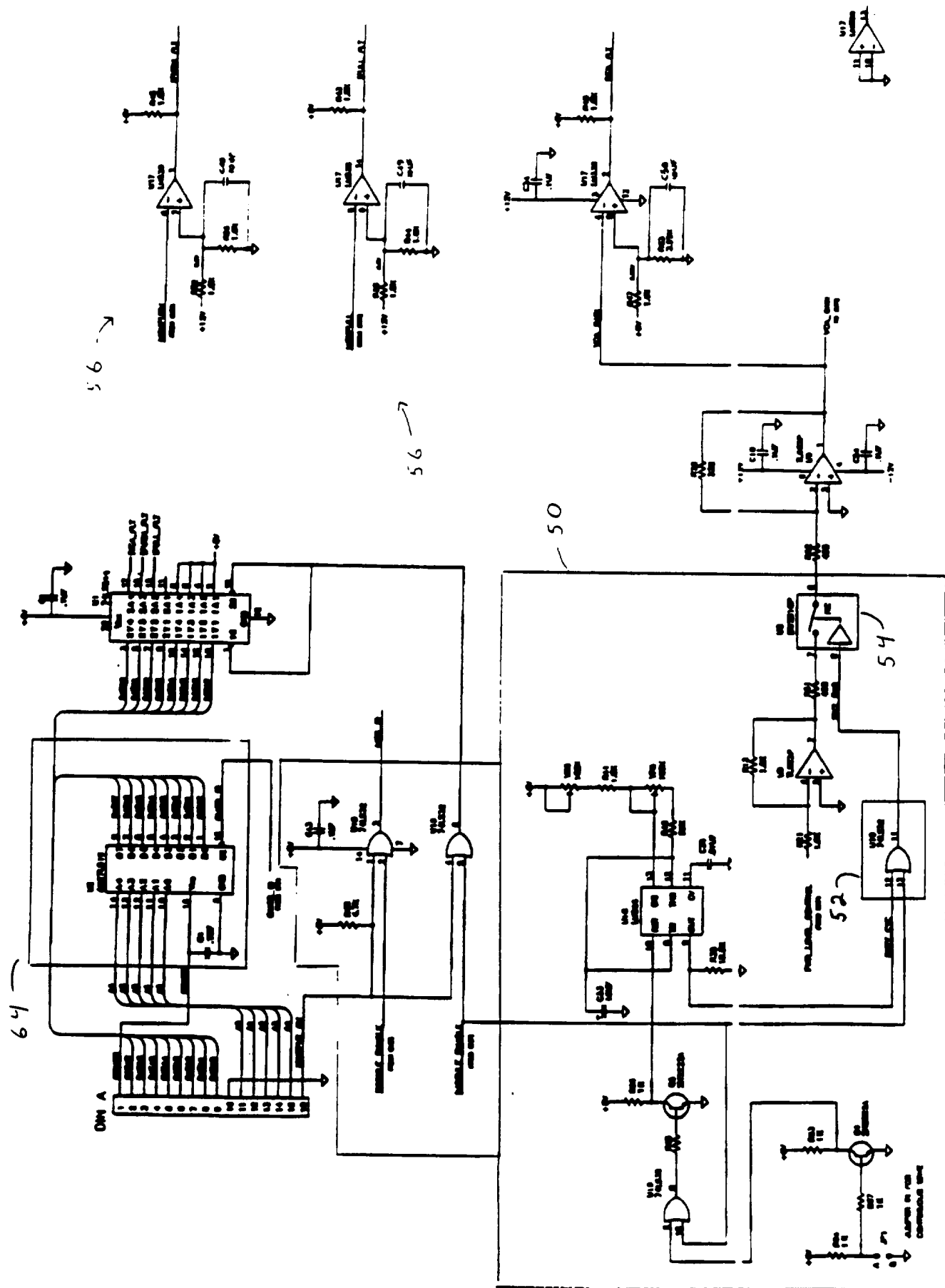

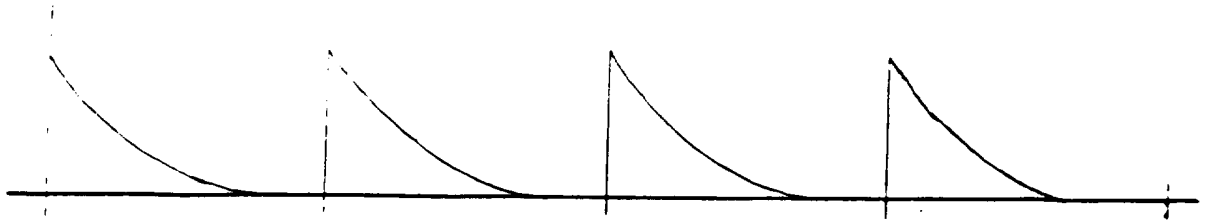

Fig. 5

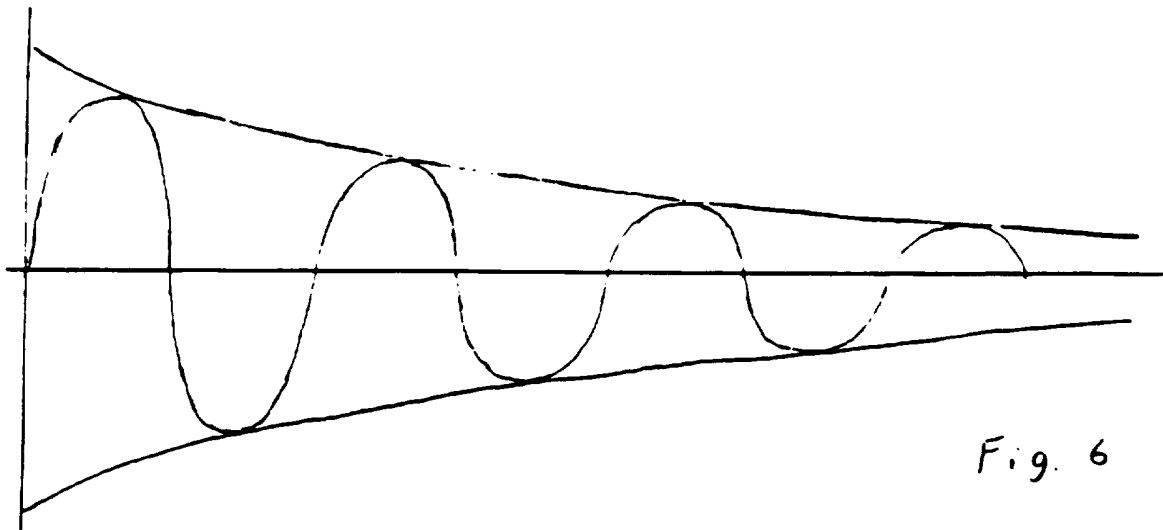

Fig. 6

INTERNATIONAL SEARCH REPORT

International application No.  
PCT/US95/13858

<b>A. CLASSIFICATION OF SUBJECT MATTER</b> IPC(6) :A61B 17/39 US CL :606/34 According to International Patent Classification (IPC) or to both national classification and IPC		
<b>B. FIELDS SEARCHED</b> Minimum documentation searched (classification system followed by classification symbols) U.S. : 606/32-34, 37-42 Documentation searched other than minimum documentation to the extent that such documents are included in the fields searched Electronic data base consulted during the international search (name of data base and, where practicable, search terms used)		
<b>C. DOCUMENTS CONSIDERED TO BE RELEVANT</b>		
Category*	Citation of document, with indication, where appropriate, of the relevant passages	Relevant to claim No.
X	US, A, 5,318,563 (MALIS ET AL.) 07 June 1994, see whole document.	1-8
---		-----
Y		1-8
A	US, A, 3,923,063 (ANDREWS ET AL/) 02 December 1975, see whole document.	1-8
A	US, A, 5,167,660 (ALTENDORF) 01 December 1992, see whole document.	1-8
<input type="checkbox"/> Further documents are listed in the continuation of Box C. <input type="checkbox"/> See patent family annex.		
*A*	Special categories of cited documents: document defining the general state of the art which is not considered to be part of particular relevance	*T* later document published after the international filing date or priority date and not in conflict with the application but cited to understand the principle or theory underlying the invention
*E*	earlier document published on or after the international filing date	*X* document of particular relevance; the claimed invention cannot be considered novel or cannot be considered to involve an inventive step when the document is taken alone
*L*	document which may throw doubts on priority claim(s) or which is cited to establish the publication date of another citation or other special reason (as specified)	*Y* document of particular relevance; the claimed invention cannot be considered to involve an inventive step when the document is combined with one or more other such documents, such combination being obvious to a person skilled in the art
*O*	document referring to an oral disclosure, use, exhibition or other means	*Z* document member of the same patent family
*P*	document published prior to the international filing date but later than the priority date claimed	
Date of the actual completion of the international search 28 MARCH 1996		Date of mailing of the international search report <b>22 APR 1996</b>
Name and mailing address of the ISA/US Commissioner of Patents and Trademarks Box PCT Washington, D.C. 20231 Facsimile No. (703) 305-3230		Authorized officer <i>Michael Peffley</i> FOR MICHAEL PEFFLEY Telephone No. (703) 308-4305