

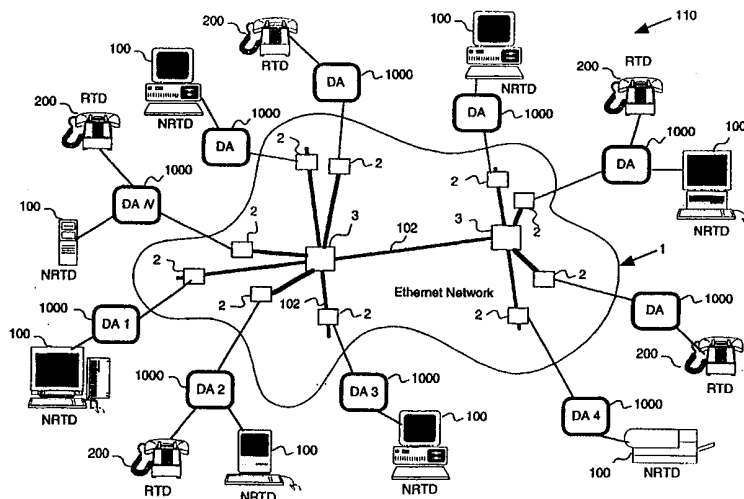

INTERNATIONAL APPLICATION PUBLISHED UNDER THE PATENT COOPERATION TREATY (PCT)

<p>(51) International Patent Classification⁶ : H04J 3/06</p>	<p>A1</p>	<p>(11) International Publication Number: WO 00/11820</p> <p>(43) International Publication Date: 2 March 2000 (02.03.00)</p>
<p>(21) International Application Number: PCT/US99/18984</p> <p>(22) International Filing Date: 18 August 1999 (18.08.99)</p> <p>(30) Priority Data: 09/136,706 19 August 1998 (19.08.98) US 09/224,577 31 December 1998 (31.12.98) US</p> <p>(71) Applicant (for all designated States except US): PATH 1 NETWORK TECHNOLOGIES, INCORPORATED [US/US]; 3636 Nobel Drive, Suite 275, San Diego, CA 92122 (US).</p> <p>(72) Inventors; and (75) Inventors/Applicants (for US only): FELLMAN, Ronald, D. [US/US]; 12989 Chaparral Ridge Road, San Diego, CA 92130 (US). CRUZ, Rene, L. [US/US]; 8058 Gilman Court, La Jolla, CA 92037 (US). PALMER, Douglas, A. [US/US]; 1229 Trieste Drive, San Diego, CA 92107 (US).</p> <p>(74) Agents: BROWN, Marc, E. et al.; Oppenheimer Wolff & Donnelly LLP, Suite 3800, 2029 Century Park East, Los Angeles, CA 90067-3024 (US).</p>	<p>(81) Designated States: AE, AL, AM, AT, AU, AZ, BA, BB, BG, BR, BY, CA, CH, CN, CR, CU, CZ, DE, DK, DM, EE, ES, FI, GB, GD, GE, GH, GM, HR, HU, ID, IL, IN, IS, JP, KE, KG, KP, KR, KZ, LC, LK, LR, LS, LT, LU, LV, MD, MG, MK, MN, MW, MX, NO, NZ, PL, PT, RO, RU, SD, SE, SG, SI, SK, SL, TJ, TM, TR, TT, UA, UG, US, UZ, VN, YU, ZA, ZW, ARIPO patent (GH, GM, KE, LS, MW, SD, SL, SZ, UG, ZW), Eurasian patent (AM, AZ, BY, KG, KZ, MD, RU, TJ, TM), European patent (AT, BE, CH, CY, DE, DK, ES, FI, FR, GB, GR, IE, IT, LU, MC, NL, PT, SE), OAPI patent (BF, BJ, CF, CG, CI, CM, GA, GN, GW, ML, MR, NE, SN, TD, TG).</p> <p>Published <i>With international search report. Before the expiration of the time limit for amending the claims and to be republished in the event of the receipt of amendments.</i></p>	

(54) Title: METHODS AND APPARATUS FOR PROVIDING QUALITY-OF-SERVICE GUARANTEES IN COMPUTER NETWORKS



(57) Abstract

An arbitration mechanism provides quality-of-service guarantees for time-sensitive signals sharing a local area computer network (110) with non-time-sensitive traffic. Device adapters (1000) are placed at all access points (2) to an Ethernet network (1). The device adapters (1000) limit admission rates and control the timing of all packets entering the network. By doing so, collisions are eliminated for time-sensitive traffic, thereby guaranteeing timely delivery. A common time reference is established for the device adapters (1000). The time reference includes a frame (20, 21, 22) with a plurality of phases (201-205). Each of the phases (201-205) is assigned to a device adapter (1000). Each device adapter (1000) is allowed to transmit packets of data onto the network (1) only during the phase assigned thereto. The length of the phases (201-205) may be modified in accordance with the number of packets to be transmitted by a particular device adapter (1000). One of the device adapters (1000) may be designated as a master timing device to synchronize each of the other device adapters.

FOR THE PURPOSES OF INFORMATION ONLY

Codes used to identify States party to the PCT on the front pages of pamphlets publishing international applications under the PCT.

AL	Albania	ES	Spain	LS	Lesotho	SI	Slovenia
AM	Armenia	FI	Finland	LT	Lithuania	SK	Slovakia
AT	Austria	FR	France	LU	Luxembourg	SN	Senegal
AU	Australia	GA	Gabon	LV	Latvia	SZ	Swaziland
AZ	Azerbaijan	GB	United Kingdom	MC	Monaco	TD	Chad
BA	Bosnia and Herzegovina	GE	Georgia	MD	Republic of Moldova	TG	Togo
BB	Barbados	GH	Ghana	MG	Madagascar	TJ	Tajikistan
BE	Belgium	GN	Guinea	MK	The former Yugoslav Republic of Macedonia	TM	Turkmenistan
BF	Burkina Faso	GR	Greece	ML	Mali	TR	Turkey
BG	Bulgaria	HU	Hungary	MN	Mongolia	TT	Trinidad and Tobago
BJ	Benin	IE	Ireland	MR	Mauritania	UA	Ukraine
BR	Brazil	IL	Israel	MW	Malawi	UG	Uganda
BY	Belarus	IS	Iceland	MX	Mexico	US	United States of America
CA	Canada	IT	Italy	NE	Niger	UZ	Uzbekistan
CF	Central African Republic	JP	Japan	NL	Netherlands	VN	Viet Nam
CG	Congo	KE	Kenya	NO	Norway	YU	Yugoslavia
CH	Switzerland	KG	Kyrgyzstan	NZ	New Zealand	ZW	Zimbabwe
CI	Côte d'Ivoire	KP	Democratic People's Republic of Korea	PL	Poland		
CM	Cameroon	KR	Republic of Korea	PT	Portugal		
CN	China	KZ	Kazakstan	RO	Romania		
CU	Cuba	LC	Saint Lucia	RU	Russian Federation		
CZ	Czech Republic	LI	Liechtenstein	SD	Sudan		
DE	Germany	LK	Sri Lanka	SE	Sweden		
DK	Denmark	LR	Liberia	SG	Singapore		
EE	Estonia						

**METHODS AND APPARATUS FOR PROVIDING
QUALITY-OF-SERVICE GUARANTEES IN COMPUTER NETWORKS**

FIELD OF THE INVENTION

The present invention is related to computer networks and, more particularly, to network
5 apparatus and associated methods that allows real-time traffic such as telephone and video to
share a computer network with non-real-time traffic. The methods and apparatus of the present
invention provide quality-of-service latency and bandwidth guarantees for time-sensitive signals
sharing, for example, an Ethernet network with non-time sensitive signals.

BACKGROUND OF THE INVENTION

10 Computer telephony, that is, the delivery of telephone calls over computer networks, has
recently become a focus of attention due to the potential cost savings of sharing these modern
high-bandwidth facilities for multiple uses. Because computer networks packetize signals and
then mix such packetized signals (or more simply, packets) from many sources over a single link,
networks can make more efficient use of communications resources than conventional circuit-
15 switched telephone systems. Furthermore, computer networks leverage the mass-production cost
savings and technological advances of commodity products. This sharing of computer
communications for non-computer signals therefore has the potential to greatly lower the cost of
communications when used with telephone signals.

20 Computer network traffic from telephone, video, and other time-sensitive sources are
generally referred to as *real-time traffic* because such traffic must arrive at a destination within a
specified deadline. Real-time traffic generated from audio or video sources is usually generated in
equally spaced time intervals. This type of periodic real-time traffic is referred to as *isochronous
traffic*.

25 When isochronous traffic is digitized and combined with the sophisticated computer-
processing compression techniques, the result is a significant reduction in bandwidth
requirements. This use of computer technology to send telephone and video signals thereby
results in even further cost savings.

However, conventional computer networks are not designed to handle real-time traffic.
Collisions and congestion can induce delays and retransmissions, and can cause real-time traffic,

such as video, audio, telemetry, and control signals, to arrive late at a destination, thereby missing a deadline. Furthermore, such collision-induced delays are stochastic by nature and therefore unpredictable. Isochronous traffic sources become bursty after traveling through such networks. As a result, the quality of telephone calls placed over the Internet and computer networks in
5 general is very poor at present.

Ethernet computer networks, in particular, use a form of media access control known as Carrier Sense Multiple Access with Collision Detect (CSMA/CD), also sometimes known as Aloha. This protocol is described in detail by the IEEE Standard 802.3. It provides a very simple and effective mechanism for allowing multiple packet sources to share a single broadcast
10 computer network medium. To transmit a new packet, a transmitter need only listen to the network to sense that no packet is currently being transmitted. As a transmitted packet is broadcast to all receivers on the local network, listening to the network for activity is trivial. If a transmitter wishing to send a packet senses that a packet is currently being transmitted, then the transmitter defers transmission until it senses that the network is inactive. Collisions naturally
15 arise as part of this mechanism. The most common scenario leading to a collision is where two or more stations, which are deferring their own respective transmissions during the transmission of another packet, sense a lack of activity at nearly the same time. The protocol detects collisions, and then aborts and reschedules transmission of all packets for a random time later. This protocol, while simple and effective for computer traffic, introduces collisions and delays as part
20 of its natural operation. In fact, overloading such a network causes the entire network to become unusable, resulting in a significant reduction in throughput.

Ethernet is now ubiquitous throughout the Internet within local-area computer networks, or intranets. The use of variable packet sizes and Carrier Sense Multiple Access with Collision
25 Detect for link access and control creates an even less predictable and less controllable environment for guaranteeing quality of service. This is of particular concern for wide-area real-time traffic that must traverse a plurality of Ethernet networks in order to reach a final destination.

Description of Relevant Prior Art

A conventional Ethernet network **1** is shown in FIG. **1a**. Conventional Ethernet devices
30 **100**, such as personal computers and printers, generate non-real-time traffic and are referred to herein as Non-Real-Time Devices (NRTDs). The NRTDs **100** have a standard Ethernet interface and attach to the conventional Ethernet network **1** through Network Interface Points **2**. The Network Interface Points **2** could represent a 10Base-T port, a 100Base-TX port, a 10Base-2

(ThinLAN) port, for example. The Network Interface Points **2** may be interconnected by Repeaters or Ethernet Hubs **3**.

In conventional Ethernet networks, the attached devices **100** are called stations. When a station transmits a packet on the network, the signal is broadcast throughout the network. For a transmission to be successfully received by another station, there must be no other simultaneous transmissions. Thus, an arbitration mechanism to share the network is required. Ethernet networks use an arbitration mechanism known Carrier Sense Multiple Access with Collision Detect (CSMA/CD).

FIG. **1b** provides an example that illustrates how the CSMA/CD protocol works. A time line of events is illustrated, representing the actions of five stations, labeled Station A, Station B, Station C, Station D, and Station E. These five stations could represent the five NRTDs in FIG. **1a**, for example. In this example, Station A transmits a packet **10** on the network after sensing that the network is idle. During the transmission of this packet **10**, Station B generates a packet **12** to transmit on the network, but defers the transmission (indicated by numeral **11**) because Station B senses activity on the network, due to the transmission **10** from Station A. As soon as Station B senses that the network is idle, Station B waits an additional amount of time, known as the Inter-Packet Gap (IPG) **19**, prior to transmitting a packet onto the network. In 10Mbit/sec Ethernet networks, for example, the IPG is defined to be 9.6 microseconds, or 96 bit times. This constraint results in a minimum time spacing between packets. After Station B waits for an additional IPG seconds, it transmits the queued packet **12**. Accordingly, by sensing the network for activity, collisions can be avoided. Collisions, which occur when two or more stations transmit simultaneously on the network, are still possible, however, due to non-zero latency of detecting the state of the network and non-zero propagation delay of signals between the stations.

As shown in FIG. **1b**, for example, after Station B finishes transmitting a packet **12**, the network becomes idle. Sometime later, Station C transmits a packet **13** on the network after sensing that the network is idle. During this transmission from Station C, both Stations D and E each happen to generate a packet for transmission onto the network. As activity is detected on the network, due to the transmission **13** from Station C, Stations D and E defer their respective transmissions (indicated by numerals **14** and **15**) until the network is sensed idle. Stations D and E will sense that the network is idle at nearly the same time and will each wait an additional IPG **19** before transmitting their respective packets. Station D and Station E will then start transmitting packets on the network at nearly the same time, and a collision **16** then occurs

between Station D and station E. The second station to start transmitting during the collision, say Station E, may or may not be able to detect the beginning of the transmission from the first station that starts transmitting, say Station D. In the latter case, Station E does not know that a collision will occur when beginning transmission. In the former case, Station E is still allowed to start transmitting the packet, even though Station E “knows” that transmission will cause a collision, as long as no activity is detected during the first 2/3 of the IPG. This provision provides a degree of fairness in preventing certain stations from monopolizing the network, due to timing differences across stations or location-dependent factors. During the initial part of the transmissions from Stations D and E, both stations sense that a collision occurs, continue to transmit for 32 bit times, and then abort the transmission. The process of prolonging the collision for 32 bit times is called “jamming” and serves the purpose of ensuring that all stations involved in a collision will detect that a collision has in fact occurred. By aborting transmission after the “jamming” process, the network becomes idle sooner than otherwise. After a station involved in a collision aborts transmission, such a station waits a random amount of time before attempting to transmit again. If the stations involved in the collision wait for different amounts of time, another collision is avoided.

The process of waiting a random amount of time until attempting transmission again, after aborting a transmission due to a collision, is called “backing off.” The CSMA/CD protocol uses a backing-off mechanism known as binary exponential back off, which is now described. A slot time T is defined to be 512 bit times. For example, in 10 Mbit/sec Ethernet networks, slot time T is approximately 50 microseconds. After a station experiences k collisions for a given packet it is attempting to transmit, the station waits for a time iT before attempting to transmit again, where i is a random integer in the range $0 < i < 2^m$ and $m = \min(k, 10)$. Notice that for a packet experiencing multiple collisions, the average waiting time after each collision doubles until 10 collisions have occurred. After 16 collisions, the station will discard the packet. Such a process provides a mechanism for dynamic load adjustment—many collisions imply a congested network, so the rate of retransmissions is reduced to decrease the probability of further collisions.

After backing off, a station again senses the network for activity, deferring if necessary before transmitting again. For example, as shown in FIG. 1b, while Station D is backing off (indicated by numeral 17), Station F generates and transmits a packet 18 after detecting that the network is idle. When through backing off, Station D senses activity on the network, due to the transmission 18 from Station F, and thus defers 21 retransmission of the packet. After sensing

that the network is idle, Station D then retransmits **22** the original packet that collided earlier, after waiting for IPG **19** seconds. In this example, Station E backs off (indicated by numeral **20**) for a longer amount of time, and when Station E is through backing off, Station E senses that the network is idle. Station E then retransmits **23** the packet that collided earlier. Finally, in this
5 example, Station C generates another packet **25** during the retransmission **23** of the packet from Station E, and Station C defers **24** transmission until IPG **19** after Station E completes retransmission.

As discussed earlier, a feature of CSMA/CD is simplicity. However, as noted earlier, packet delays with CSMA/CD are unpredictable and highly variable, making conventional
10 CSMA/CD unsuitable to support real-time traffic. In particular, backing off after several collisions significantly increases the latency suffered by a packet.

One variant of the Ethernet computer network, known as Isochronous Ethernet, also transmits isochronous data but uses a frame form that is not itself packetized. Thus, in Isochronous Ethernet, a special network adapter is required that fragments packets into pieces
15 and then transmits each piece of a packet during a respective time slot of precise and fixed duration. Another specialized network adapter at the receiving end then needs to reconstruct the packet from the pieces for delivery to the device connected thereto. Thus, one drawback is that such Isochronous Ethernet network adapters are not directly compatible with conventional Ethernet network hardware, so that special equipment is required. There are no time periods
20 wherein a regular Ethernet packet may simply flow through a time slot on route. All Ethernet packets are fragmented and placed into multiple time slots. Another drawback is that precise synchronization and scheduling among the Isochronous Ethernet network adapters are crucial for this type of network to function effectively. There is no CSMA/CD protocol within Isochronous Ethernet to avoid collisions should two nodes overlap in their timing. Isochronous Ethernet uses
25 only fixed-sized frames and time slots, so that network bandwidth may be wasted should one or more slots not be utilized. Additional mechanisms for providing isochronous channels within an Ethernet network are described in U.S. Patent Nos. 5,761,430 and 5,761,431. While the mechanisms set forth in these patents may overcome some of the drawbacks of Isochronous Ethernet by maintaining compatibility with standard Ethernet, their utility for sending large
30 volumes of non-real-time computer traffic is limited by the requirement of timing and scheduling the transmission of all non-real-time packets, as well as real-time packets. Furthermore, like Isochronous Ethernet, the mechanisms set forth in these two patents also require precise

synchronization corrections to be propagated throughout the network in each frame. In sending such synchronization packets on a frequent per-frame basis, the large amount of time uncertainty and jitter inherent in Ethernet transmissions and computer interrupt processing actually introduce further synchronization errors and jitter at each frame in these systems. And by requiring a reservation list to be included in each per frame beat packet, the resulting larger synchronization packet size for these conventional mechanisms further increases the potential for timing jitter.

The mechanisms of these two patents further require the dynamic scheduling of packet transmission on a frame-by-frame basis according to the presence or the absence of packets sensed per time interval on the network. Therefore, these mechanisms become untenable for large numbers of independent sources of traffic, as all stations must correctly monitor all packets. Such a system does not scale well to networks with a large number of nodes. In addition, were any single station to encounter an error in reading any of the broadcast packets, such a station could fall out of sync with the rest of the system.

In view of the foregoing, there is still a need in the art for network apparatus and associated methodology that overcomes the limitations of CSMA/CD and provides quality-of-service guarantees in computer networks for real-time traffic, while still maintaining full compatibility and utility for non-real-time traffic.

SUMMARY OF THE INVENTION

The present invention provides network apparatus and associated methods for minimizing or substantially eliminating unpredictable delays in networks, particularly broadcast or Ethernet networks. One aspect of the present invention is its ability to create virtual isochronous channels within a CSMA/CD Ethernet network. The present invention provides an arbitration mechanism to control access to the network for time-sensitive signals and to minimize or substantially eliminate collisions. In an Ethernet network, this arbitration mechanism of the invention augments the underlying CSMA/CD arbitration mechanism.

At regular intervals (or "frames"), dedicated time slots (or "phases") are defined during which real-time traffic may be transmitted. A plurality of network devices of this invention are synchronized together to define such frames to coincide on well-defined, periodic boundaries. This invention also provides an associated synchronization mechanism that minimizes jitter and timing uncertainty of frame and phase boundaries. The arbitration mechanism allows the real-time traffic to arrive at its destination with a very low and predictable delay. The introduction of

predictability and a tight bounding on the delay allows the network to set guarantees for service quality.

According to one aspect of the present invention, a network for communicating packets of data includes a plurality of devices, for example, real-time and non-real-time devices, and a network medium. A plurality of device adapters connects the devices to the network medium. Each device adapter includes a device interface connected to one of the devices and for receiving packets generated thereby and a network interface connected to the network medium. Each device adapter also includes a processor connected to each of the interfaces for receiving the packets from the device interface and for transmitting the packets to the network interface.

One of the plurality of device adapters may serve as a master timing device that synchronizes a common time reference of the plurality of devices. Alternatively, a master timing device may be incorporated within a specialized Ethernet repeater hub. The common time reference defines a frame of time which, in turn, has a plurality of phases and repeats cyclically. Each of the phases is assigned to a respective device adapter. More than one phase can be assigned to a given device adapter. Each of the device adapters is allowed to transmit the packets received at the device interface during the phase assigned thereto. Accordingly, as no device adapter is able to transmit packets out of phase, collisions are eliminated for packets transmitted in the assigned phases. Furthermore, if a synchronization mismatch occurs, the underlying CSMA/CD protocol intercedes to sense the transmission of a packet in a prior phase and to dynamically hold off transmission of a packet from a succeeding phase so as to prevent a collision. There are no collisions so long as the phase overlap does not exceed the time duration of a minimum-sized packet. Another advantage is that the packets do not need to be reformatted after transmission, so that compatibility with standard Ethernet is maintained.

The plurality of phases may also include a free-access phase, common to all connected device adapters, during which any of the device adapters is able to transmit packets according to, for example, the standard IEEE 802.3 CSMA/CD protocol. The device adapters may use information stored in a header of a packet received from an attached device to determine whether to forward a received packet in an assigned phase, or as a non-real-time packet in the common free-access phase. If a packet is sent in an assigned phase, service quality is guaranteed for the packet. Otherwise, if a packet sent in a free-access phase, the packet contends for network access along with all other device adapters.

The plurality of phases may also include one or more guard phases during which none of the device adapters is able to transmit packets. A guard phase compensates for variations in signal delays between the device adapters. The optional use of a guard phase and CSMA/CD protocol, even among assigned phases, eliminates the need for precise synchronization. Should the transmission time of a first packet extend beyond its assigned phase or a following guard phase, the device adapter associated with the next assigned phase senses this transmission and defers transmission of a second packet until the first packet transmission is completed.

No collisions occur among packet transmissions during assigned phases so long as the device adapters synchronize their phases to within a synchronization tolerance time. This synchronization tolerance time is calculated as the duration of a minimum-sized packet. In the case where a first device adapter sends a first packet within its assigned phase and a second device adapter attempts to transmit a second packet in a subsequent phase, this tolerance assures that the CSMA/CD mechanism will sense the first packet and delay transmission from the second device adapter sending the second packet until the first packet transmission has been completed. Thus, device adapters of this invention only need to be in *substantial* synchronization and not precise or exact synchronization. Furthermore, a guard phase at the start of a new frame may provide a settling period for any queued packets from the prior free-access phase to ensure that a synchronization signal or a packet from the first assigned phase does not experience collisions. Each of the phases has a pre-assigned length of time that may vary in proportion to the number of packets scheduled for transmission at the device interface of a respective the device adapter. Accordingly, if a particular device connected to a device adapter is not generating a large number of packets, then the phase assigned to that device adapter may be shortened to eliminate idle time on the network. On the other hand, if a particular device generates a large number of packets, then the phase assigned thereto may be lengthened to accommodate the large traffic. Furthermore, a device adapter is able to use any unused time in an assigned phase that may otherwise be wasted to transmit non-real-time traffic and thereby improve network efficiency of this invention.

The network of the invention may include a plurality of real-time devices, such as telephones, and non-real-time devices, such as computers. The non-real-time devices may include a number native non-real-time devices connected to the network medium directly. When there is a surplus of time to meet deadlines for real-time devices, the transmission of real-time packets may be delayed in deference to non-real-time packets generated by the native non-real-time

devices. However, collisions may be forced for non-real-time packets when a scheduled real-time packet may otherwise miss a deadline.

Another aspect of the present invention is the underlying synchronization mechanism. This synchronization mechanism may utilize the availability of inexpensive and stable crystal oscillators (XO). The crystal may be a variable crystal oscillator (VXO) with a narrow range of frequency adjustment, although this is not a requirement for achieving adequate synchronization according to the invention. The XO or VXO operates primarily as a free-running oscillator wherein the accumulated phase mismatch is corrected via an occasional incoming timing signal. When using a VXO, a separate VXO frequency correction signal is generated from the aggregate of many timing-signal phase mismatch measurements to fine-tune the VXO frequency. When using an XO, frequency correction can be achieved through periodic incremental phase adjustments. One of the device adapters may be designated as the master timing device. In this case, the other device adapters, called slave devices, synchronize their internal clock to the master timing source device. Alternatively, the master timing device may be incorporated into a specialized Ethernet repeater hub. In this latter case, all of the attached device adapters function as slave devices and synchronize their internal clock to the master timing source device.

The drift and native frequency mismatch of the slave crystal oscillators (operating under a null correction voltage) with respect to the master sets an upper bound on the frame length. The amount of phase drift when operating with no correction voltage must be small in relation to a minimum packet transmission time. In a preferred embodiment of the invention configured for an Ethernet environment, this phase-drift tolerance typically is on the order of an Ethernet inter-packet gap (IPG) over a period of many frame times, typically 10 or greater. Thus, having a correction signal occur within this number of frames synchronizes the common time reference to within an IPG time. The VXO approach of this invention restricts frequency adjustment to a narrow range, uses regression techniques to account for variations in network delays in the determination of the magnitude of the correction, and separates the phase synchronization from the frequency fine-tuning.

Another aspect of the present invention is that the synchronization mechanism may use two types of synchronization signals: a fine resolution synchronization signal and a coarse-resolution synchronization signal. The fine resolution synchronization signal of the present invention need not carry any explicit information, and instead conveys information implicitly through its arrival time. Fine resolution synchronization signals are sent at fixed times relative to

the time reference of the master timing source, for example, at the beginning of a frame as defined by the master timing source. In this case, the arrival of the fine resolution synchronization signal at a device adapter triggers a phase-synchronization event at said device adapter, adjusting the next frame boundary if necessary to coincide with the arrival time of the fine resolution

5 synchronization signal plus the nominal duration of the frame. However, the coarse resolution synchronization signal, which is in the form of a frame time-stamp packet, contains a full count of the current time at which the packet is sent, relative to the master timing device. A coarse resolution synchronization signal can therefore arrive at anytime during the frame to which it refers. If used in conjunction with a fine resolution synchronization signal, the time stamp carried

10 by a coarse resolution synchronization signal need only be precise enough to resolve the current time to within a duration of a frame. The fine resolution synchronization signals, if used, may either be sent via the master timing source or delivered to the device adapters through some external mechanism. The aspect of the present invention of a plurality of fixed-length phases, each given phase being available for the entire duration of its associated isochronous stream,

15 enables the use of Time Division Multiplexing (TDM) as a scheduling mechanism. By predetermining the length of each phase and the streams to which each phase belongs, the TDM scheduling of the present invention assigns isochronous streams to specific phases. This simplifies implementation and robustness by introducing predictability to a system. In TDM, a preset set of times can be broadcast and used to time all packet transmissions.

20 Advantages of the present invention over conventional approaches for handling real-time traffic include:

compatibility with conventional network devices operating under the IEEE 802.3 standard Ethernet specification;

25 use of the CSMA/CD media access of IEEE 802.3 for self-adjustment of phase mismatches to further prevent collisions among real-time packets;

ability to provide real-time service guarantees without monitoring or dynamic scheduling of real-time traffic; and

synchronization stability over many frames without the requirement for frequent (per frame) resynchronization.

30 As a result, devices of the present invention can co-exist in systems incorporating conventional Ethernet interfaces and will not adversely affect an existing network. For example, since the device adapters of this invention do not need to monitor real-time traffic, the device adapters can

be used with standard switches and routers, as well as standard repeater hubs. Furthermore, the specialized Ethernet repeater hubs of this invention can be used with standard Ethernet devices.

Other aspects, features, and advantages of the present invention will become apparent to those persons having ordinary skill in the art to which the present invention pertains from the following

5 description taken in conjunction with the accompanying drawings.

BRIEF DESCRIPTION OF THE DRAWINGS

FIG. 1a is a schematic view of a conventional Ethernet network;

FIG. 1b is a schematic diagram illustrating a CSMA/CD arbitration mechanism in a conventional Ethernet network;

10 FIG. 2 is a schematic view of an exemplary Ethernet network in accordance with the present invention, particularly illustrating a Conditioned Mode of the network, in which real-time devices and conventional Ethernet devices are attached to the Ethernet network;

FIG. 3 is a block diagram of an exemplary device adapter of the present invention wherein two Ethernet ports, one dedicated to non-real-time traffic and another dedicated to real-time traffic, are mixed onto a third port that conditions an Ethernet link to allow a mixture of real-time and non-real-time traffic;

FIG. 4 is a graphical view illustrating the organization of time into repeating frames and time intervals within each frame that define allowable phases for each device to transmit time-sensitive traffic (Conditioned Mode);

20 FIG. 5 is a graphical view illustrating an arbitration mechanism in Conditioned Mode of the invention, particularly illustrating the arbitration mechanism in which the duration of each phase is fixed;

FIG. 6 is a block diagram of an exemplary specialized Ethernet repeater hub of the present invention, which repeater hub includes a means for generating and transmitting synchronization signals to the device adapters.

FIG. 7 is a schematic view of an exemplary Ethernet network in accordance with the present invention, particularly illustrating an Annex Mode of the network, in which real-time devices and conventional Ethernet devices are attached to the Ethernet network;

30 FIG. 8 is a graphical view illustrating the organization of time into repeating frames and time intervals within each frame that define allowable phases for each device to transmit time-sensitive traffic (Annex Mode)

FIGS. 9a and 9b are graphical views illustrating respective exemplary arbitration mechanisms of the present invention in Annex Mode;

FIGS. 10a, 10b, 10c, 10d, 10e, and 10f are flowcharts illustrating respective exemplary embodiments for packet transmission procedures for a Device Adapter of the present invention, covering both Conditioned Mode and Annex Mode;

FIG. 11 is a block diagram of a specialized Ethernet repeater hub incorporating a master timing source and associated configurable processor, as well as ports for prior art Ethernet devices; and

FIG. 12 is a block diagram of a specialized Ethernet repeater hub incorporating a master timing source and associated configurable processor, as well as ports that can be configured to connect to either device adapters or prior art Ethernet devices.

DESCRIPTION OF THE INVENTION

Referring to the drawings in more detail, an enhanced network 110 in accordance with the present invention is illustrated in FIG. 2. As will be discussed in more detail below, exemplary network 110 includes a plurality of devices 100 and 200 for generating real-time and/or non-real-time packets of data for transmission across a network medium 112 to a destination on the network 110. Exemplary network 110 also includes a plurality of device adapters (DAs) 1000 which ensure that at least the real-time packets arrive at their destination without colliding with other packets, thus guaranteeing a quality of service unavailable with conventional computer networks.

In addition to the hardware associated with the network 110, the present invention provides an arbitration mechanism to control access to the network for time-sensitive signals and to minimize or substantially eliminate collisions. As discussed in more detail below, at regular intervals (or "frames"), dedicated time slots (or "phases") are defined during which real-time traffic may be transmitted. The arbitration mechanism allows the real-time traffic to arrive at its destination with a very low and predictable delay. The introduction of predictability and a tight bounding on the delay allows the network to set guarantees for service quality.

Continuing to reference FIG. 2, the plurality of device adapters 1000 are connected to the network 110 at network interface points 2. Real-time devices (RTDs) 200, such as telephones and video equipment, are attached to the device adapters 1000. Non-real-time devices (NRTDs) 100, which are attached directly to network interface points in conventional networks, are

preferably connected to the device adapters **1000** in accordance with the present invention. The network **110** shown in FIG. **2** is configured in "Conditioned Mode," as all traffic placed on the network is conditioned by the device adapters **1000**. The network includes another mode, called "Annex Mode," which will be discussed in more detail below.

5 The network **110** may include a broadcast portion **1**. The broadcast portion **1** is an environment in which packets generated by one station are transmitted to each of the stations on the network (i.e., packets are broadcast throughout the network). Accordingly, collisions would occur in the broadcast portion **1** if the device adapters **1000** of the present invention were not present to control the transmission of packets. The broadcast portion **1** may be an Ethernet
10 network or another type of network generally operating in a broadcast environment.

 An exemplary embodiment of a device adapter **1000** of the present invention is illustrated in FIG. **3**. Exemplary device adapter **1000** includes a processor **1002** and a plurality of interfaces **1004**, **1006**, and **1008**. Interface **1004** is connectable to non-real-time devices **100**; interface **1006** is connectable to real-time devices **200**; and interface **1008** is connectable to the network **110**.
15 Each device adapter **1000** may also include a local clock **1010** such as a crystal oscillator and a memory **1012**. The memory **1012** is connected to and controlled by the processor **1002**. In addition to the embodiment shown in FIG. **3**, the memory **1012** may be connected directly to the device interfaces **1004** and **1006** or to the network interface **1008** for storing both real-time and non-real-time packets prior to transmission.

20 As will be discussed in more detail below, the processor **1002** operates in accordance with an arbitration mechanism that substantially eliminates collisions of real-time traffic. The device adapters **1000** may be configured as stand-alone devices which may be connected to the network medium **112**, the real-time devices **100**, and the non-real-time devices **200**. Alternatively, the device adapters **1000** may be configured as adapter cards which may be inserted in expansion
25 slots in, for example, computers (illustrated as NRTDs **100** in FIG. **2**) connected to the network **1**.

 The RTDs **200** may output data across a standard Ethernet interface. Conventional telephone and video equipment may be interfaced to the device adapters **1000** through an additional device which formats the output of the conventional equipment into Ethernet packets.
30 Such additional formatting devices may be physically incorporated into the device adapters **1000**.

 To make efficient use of the broadcast medium **1** of the network **110**, arbitration mechanisms of the present invention provide the capability of eliminating collisions and

congestion in the network. This is accomplished by establishing a common time reference among the device adapters 1000, and then using the common time reference to define periods of time when a particular device adapter has the exclusive right to transmit packets on the network.

One exemplary arbitration mechanism of the invention for obtaining a time reference is to assign one of the device adapters 100 as a master timing device that transmits a synchronization signal at regular intervals or periodically to synchronize the local clock 1010 of each adapter. Alternatively, as discussed in more detail later, the master timing device may be incorporated into a specialized Ethernet repeater hub. The synchronization signal may be sent every predetermined number of frames, such as every hundred frames at the start of a frame, or every predetermined amount of time, such as 12.5 ms or 25 ms.

In addition, a slave device (i.e., a device adapter which is not the master timing device) may predict or measure the drift of its local clock 1010 with respect to the clock 1010 or time signal of the master timing device. The slave device may then use this drift measurement to adjust its local clock 1010 at regular intervals between synchronization signals from the master timing device. This technique allows the master timing device to transmit synchronization signals at less frequent intervals yet still adequately compensate for local oscillator drift. For example, if the local clocks 1010 are crystal oscillators, then the slave device may predict the drift with relative accuracy. If the drift is predicted to be about 60 μ s for every second, then for a frame having a length of 25 ms, each slave device would adjust its local clock by 1.5 μ s per frame, or equivalently, by 60 μ s after each 40 frames. If 60 μ s of clock mismatch are required, then this technique may significantly extend the time interval between master synchronization signals to far longer than one second. Or alternatively, this technique may provide for a significant tolerance to loss or delay of a synchronization signal.

Alternative methods for obtaining a common time reference will be discussed below. In the case where a standard Ethernet repeater hub 3 is used to interconnect device adapters, a master timing device may be defined as the first of the device adapters 1000 to come on line. If a master timing device goes off line, then a second of the device adapters 1000 to come on line may become the new master timing device, and so on.

By definition, if at a given point in time the common time reference is t , then each of the device adapters 1000 knows the value of t to within a bounded error e , and the absolute value of the difference between the estimates of the common time reference at any two device adapters

1000 is upper bounded by e . For purposes of explanation, it is helpful first to assume that $e = 0$ so that each device adapter knows the exact value of the common time reference.

Arbitration Mechanism

In contrast to conventional arbitration mechanisms, the present invention provides a mechanism in which repeating periodic frames are defined. Each of the frames has an assigned section and an unassigned (or free-access) section. Access to the assigned section is regulated and coordinated while access to the unassigned section is not. The unassigned section may operate in accordance with conventional CSMA/CD Ethernet protocol and may be used for the transmission of non-real-time packets. The assigned section is synchronized, and transmission of packets during the assigned section is coordinated among all the other devices to eliminate collisions. The assigned section is primarily reserved for real-time packets because such packets may be guaranteed with a fixed delivery time or delivery within a deadline.

An exemplary arbitration mechanism of the present invention defines repeating periodic time frames. Each time frame has an assigned (or "owned") section and an unassigned (or "free-access") section. The assigned section is divided into a plurality of phases corresponding to the plurality of device adapters 1000. Each of the phases is assigned to (that is, is owned by) one of the device adapters 1000. Each device adapter 1000 is allowed to transmit packets of date, for example, real-time packets from RTDs 200, only during its assigned (or owned) phase, and is not allowed to transmit packets during the phase assigned to another device adapter. Accordingly, collisions between packets, particularly, real-time packets is eliminated. Each device adapter 1000, however, is allowed to transmit packets during the unassigned (or free-access) phase. This exemplary arbitration mechanism will be discussed in more detail below with particular reference to FIG. 4.

As mentioned above, the network of the present invention includes a plurality of device adapters 1000, which plurality is represented by N . The device adapters 1000 may then be respectively indicated by DA1, DA2, DA3, ... DAN. Referring to FIG. 4, time is divided into equal length frames 20, 21, and 22 of duration F , for example, 25 ms. Only three exemplary frames 20, 21, and 22 are shown; however, the frames repeat at a periodic rate. For purposes of this discussion, an embodiment of the network 110 includes four device adapters, i.e., $N = 4$. Relative to the common time reference, the frame boundaries are at times $t = nF$, where n is an integer. Each frame 20–22 is divided into $N + 1$ non-overlapping intervals called *phases*, which

phases are labeled $p = 1, 2, 3, \dots N + 1$. In the exemplary embodiment shown in FIG. 4, five phases 201, 202, 203, 204, and 205 for the first frame 20 are shown.

Although each device adapter may own one or more phases, to simplify the explanation of the operation of the present invention, we will take the example where the first N phases are phases respectively owned by the device adapters 100, and which phases are generally indicated by numeral 26. That is, if p satisfies $1 \leq p \leq N$, then phase p is owned by or assigned to DA_p . A device adapter 1000 is not allowed to transmit packets in any phase except for the phase owned thereby. That is, in this example, device adapter DA1 only transmits in phase 1; device adapter DA2 only transmits in phase 2; and so on. Accordingly, collisions are eliminated during owned phases. The network 110 is then said to be operating in Conditioned Mode. If real-time traffic is transmitted only during owned phases, then this arbitration mechanism eliminates collisions for real-time traffic. The device adapters 1000 may store packets awaiting transmission during the assigned phases 26 in the on-board memory 1012. Alternatively, such packets may be stored in the memory of the generating device 100 or 200 itself.

The assignment of phases 201–205 to the device adapters 1000 may be coordinated by a master scheduling device in response to requests from the other devices. The determination of which device adapter is to be the master scheduling device may be analogous to the determination of the master timing device discussed above; that is, the master scheduling device may be defined as DA1, with each device coming on line subsequently respectively defined as DA2, DA3, and so on. If a specialized Ethernet repeater hub is employed to interconnect the device adapters, a processor within the specialized Ethernet repeater hub may serve as the master scheduling device. Alternatively, the master scheduling device may not be a device adapter but may be another device, such as a computer, connected to one of the device adapters. The master scheduling device may transmit a frame-start signal at the start of every frame 20, 21, 22, and so on. The number of phases in each frame may be defined or created by the master scheduling device in accordance with the number device adapters 1000 that are on line. Accordingly, the number of phases may vary from frame to frame, and the length of each phase may vary within a frame, as well as from frame to frame, in accordance with the volume of packets to be transmitted by a particular device. The master scheduling device may broadcast this information to the device adapters 1000 at the start of each frame. Alternatively, the phases may be of equal length with each device adapter 1000 choosing an unassigned phase by transmitting during the phase, thereby having that particular phase now assigned to the particular device adapter.

Each of the frames **20–22** may have a “guard” band or phase at the start of each frame during which no device adapter **1000** is allowed to transmit packets. The guard phase accounts for variations in signal delays and variability in quenching free-access transmissions from the previous frame. The guard phase will be discussed in more detail below.

5 With reference to FIG. **2**, the network **110** of the present invention may include bridges (switches) and routers. If included, then the bridges and routers are used in place of or in conjunction with repeater hubs **3** within the network. The time synchronization of the device adapters **1000** can still function to eliminate congestion and contention at the bridge, thereby preserving deadlines and guaranteeing quality of service for real-time signals. Furthermore, the
10 aspect of the invention whereby real-time transmissions are pre-assigned phases at the time of the setup of a real-time or isochronous channel allows the invention to avoid the monitoring of the network for determining transmission times. This permits a network of this invention to utilize prior art bridges and routers, as well as bridges and routers incorporating device adapters of this invention.

15 If the latency of the bridges or routers is small with respect to the duration of a phase, then the traffic conditioning and real-time quality- of-service guarantees of the present invention will continue to function as described. If the latency of prior art bridges or routers is substantial with respect to the duration of a phase, it may be desirable to surround the prior art bridge or router with device adapters **1000**. Alternatively, the device adapters **1000** of the invention may be
20 physically and logically incorporated within a bridge or router. In this case, the device adapters subdivide the network into multiple conditioned domains for each side of a bridge or router wherein a separate framing structure is used within each domain to continue to guarantee service quality. However, in this latter case, there may be at least an additional frame of delay added to the overall latency for packets crossing a conditioned domain.

25 With continued reference to FIG. **4**, in addition to the owned or assigned phases **26**, each frame **20, 21, 22** includes an unassigned, unowned, or free-access phase which is indicated by numeral **27**. The free-access phase **27** is defined as phase $N + 1$. The free-access phase **27** is defined as a phase in which any of the device adapters **1000** may transmit packets of data. Although the free-access phase **27** may be at any location within the frame, the free-access phase
30 is shown in the drawings as the last phase of a frame.

Arbitration within the free-access phase **27** may operate in accordance with the CSMA/CD protocol. Therefore, collisions may occur during the free-access phase **27**. Each

device adapter 1000 transmitting a packet during the free-access phase may do so without crossing a frame boundary 28. Thus, towards the end of the free-access phase, a device adapter 1000 may have to refrain from transmitting a packet to ensure that it does not improperly transmit during the following phase.

5 Each of the phases 1, 2, 3, ... N has a length of time indicated by x_1, x_2, \dots, x_N , respectively. Time x_{fa} is the length of the free-access phase 27. As the length of each frame is preferably constant, as represented by F , then the summation of the lengths of the phases 26 and 27 equals the length of the frame, i.e., $x_1 + x_2 + \dots + x_N + x_{fa} = F$.

An embodiment of the arbitration mechanism of the present invention is illustrated in FIG. 10 5. In this embodiment, the lengths of the phases 301–305 are constant across the frames. In describing the embodiment, four device adapters (i.e., $N = 4$) are provided, for example. In each frame 30, DA1 transmits two packets 31 and 32 during a first phase 301 with each packet separated by an inter-packet gap (IPG) 19; DA2 transmits a packet 33 during a second phase 302; DA4 transmits a packet 34 during a fourth phase 304, and two packets 35 and 36 are transmitted 15 during a fifth phase 205 separated by a collision 37. During phase p , DA_p can transmit real-time traffic as well as non-real time traffic, where $1 \leq p \leq N$. In this example, DA 3 does not transmit any packets during its assigned phase.

As mentioned above, each of the frames 30 may include a guard phase 300 at the start of the frame during which time no device adapter 1000 is allowed to transmit packets. If the device 20 adapters 1000 are not precisely synchronized, then there may be variations in the signal delays of the packets. The guard phase 300 provides a time period in which any such variations in signal delays of the device adapters 1000 are compensated. In addition, the guard phase 300 allows any packets transmitted during the free-access phase 305 from the previous frame, which may not have yet reached their destination, to be delivered. Accordingly, the guard phase 300 is a period 25 of time during which no new packets are transmitted and the network 110 is essentially quiet. In the embodiment including the guard phase 300 at the beginning of each frame, the device adapters 1000 do not need to be precisely synchronized but may operate somewhat out of synch and still guarantee a high quality of service in delivering real-time packets.

Another possible embodiment for an arbitration mechanism of the present invention is to 30 eliminate the free-access phase 405, i.e., $x_{fa} = 0$, and to dynamically allocate the durations of the owned phases through a token passing mechanism, as in some token ring protocols such as FDDI.

Synchronization

Referring to FIG. 2, according to an exemplary embodiment of the invention, where a standard Ethernet repeater hub **3** is used to interconnect the device adapters, one of the device adapters **1000** may be designated as a master timing device. Any of the device adapters **1000** can be chosen as a master timing device. This master timing device may be the same device adapter as the master scheduling device discussed above or a different device adapter. Furthermore, the master scheduling device and/or the master timing device may not necessarily be device adapters, but some other device, such as a personal computer (PC), compatible with the device adapters of this invention and serving the purposes of this invention. The selection of the master timing device may be determined through either an initialization protocol or a preset switch setting. In a preferred embodiment, an initialization protocol uses a first-initialized-chosen scheme, wherein the first DA **1000** to complete initialization would be chosen as the master, preventing other DAs from becoming a simultaneous master. Alternatively, a lowest media access control (MAC) address-chosen scheme may be used, wherein the master is the device adapter with the lowest MAC address. Regardless of how the master is chosen, the protocol may also include a mechanism to choose an alternate master. The alternate master becomes the master if the protocol senses that the primary (i.e., first-chosen) master has gone off-line.

Alternatively, a specialized Ethernet repeater hub may be used to interconnect the device adapters, which may assert itself as the master timing device. A specialized Ethernet repeater hub may also assert itself as the master scheduling device. Referring to FIG. 6, a specialized Ethernet repeater hub **3a** in accordance with the present invention is illustrated with a block diagram. Such a specialized Ethernet repeater hub **3a** may be used in place of a standard Ethernet repeater hub **3** as in FIG. 2. As indicated in FIG. 6, a specialized Ethernet repeater hub **3a** includes a standard Ethernet repeater hub **3**, a processor **1020**, an Ethernet interface **1022**, and a clock source **1021**. The processor **1020** may obtain a time reference from the clock source **1021** and use this to generate synchronization signals as discussed above. Such synchronization signals are sent as Ethernet packets to the Ethernet interface **1022**, which is connected to an Ethernet port **1024a** of the Ethernet repeater hub **3**. Such synchronization signals are then delivered to device adapters **1000** which are attached to other Ethernet ports **1024b–1024g** of the Ethernet repeater hub **3**. The processor **1020** may communicate directly with device adapters **1000**, in order to serve as a master scheduling device as described above. Specialized Ethernet repeater hubs **3a** may be interconnected with other Ethernet repeater hubs using uplink ports **1023** to increase the number

of device adapters that can attach to the network, which will become apparent to those skilled in the art.

In any case, upon selection, the master timing device sends two types of synchronization signals: a fine-resolution signal and a coarse-resolution signal. The fine-resolution signal is a frame-sync signal that may be a packet or any other reliable and precise signal source, either
5 internal to or external from the network. It is not necessary for the fine-resolution frame-sync signal to carry any explicit information because a key characteristic thereof is its time of arrival. It is preferable for the propagation time from the master device to the slave devices to have minimal jitter and uncertainty in arrival time.

10 The synchronization mechanism may also compensate for propagation delay across the network links. In one embodiment, the master timing device sends a signal to a device adapter and instructs the device adapter to return the signal to the master timing device. The master timing device may then measure the round trip delay, dividing this by two, to derive an estimate of the propagation delay from the device adapter to the master timing device. The master timing
15 device may then send this estimate to said device adapter so that said device adapter can appropriately compensate for propagation delay. By repeating this process throughout the network, each device adapter may arrange for packets sent thereby to arrive at the Ethernet repeater hub at designated times relative to phase definitions within a frame. Alternatively, each slave device adapter may directly measure the propagation delay from a repeater hub thereto by
20 sending a packet to itself by reflecting it off of the repeater hub. This technique allows each device adapter independently to measure and calibrate a synchronization offset.

It may not always be possible to directly measure the round-trip time to the source of the fine-resolution frame-sync signal, for example, when the source is external to the network. As discussed above, in a preferred embodiment, a specialized Ethernet repeater hub **3a** of the present
25 invention may connect device adapters of the present invention and provide the master timing source device. Time synchronization mismatches may be compensated by a one-way transmission from each source DA to the master device adapter during a sync calibration cycle at system initialization. In this embodiment, each device adapter acts **1000** as a slave device and transmits a sync verification signal to the specialized Ethernet repeater hub **3a**. The specialized Ethernet
30 repeater hub then measures the time offset between the clock of each slave device and its local (i.e., master) clock and sends a correction offset value back to the corresponding slave device.

Thus, each slave device equalizes the phase delay from each slave device to the specialized Ethernet repeater hub 3a to facilitate precise coordination of TDM scheduled transmissions.

After phase alignment, any remaining phase mismatch between one DA and another is small relative to a packet length. The underlying CSMA/CD media access protocol self-corrects for any such remaining phase misalignments among the DAs. A phase misalignment may manifest itself as one DA attempting to transmit either too early or too late. If a DA transmits too early, then the carrier sense of CSMA/CD suspends or holds off a transmission by a current phase until the transmission of the previous phase completes, plus one IPG time. If a DA transmits too late, then wasted link capacity results for the idle gap because the previous phase may cause an overlap with a successive phase. If the misalignment causes a late transmission, a successive phase suspends or holds off transmission by virtue of CSMA/CD. In neither case does a collision occur, as the TDM scheduling only permits a single source to transmit in a single phase.

In particular, a DA begins a packet transmission such that the transmission would terminate at the end of the phase. However, phase misalignment and possible delays in the start of transmissions due to a carrier sense hold-off may cause a transmission to carry over to the successive phase. Therefore, according to an exemplary embodiment of the invention, the start of the last packet transmission in a first phase propagates across the network before the start of a second phase. This propagation takes place for the CSMA protocol, if necessary, to sense the transmission from the first phase and to hold off the start of the second phase. By this means, the time multiplexing of this invention self-aligns phase synchronization among all adjacent phases and thereby avoids collisions during the assigned phases.

The one-way transmission delay across an Ethernet network does not exceed 264 bit times and is typically less than 20 bit times for a simple star topology (for a background on such delay, see "The Evolving Ethernet," Alexis Ferrero, Addison Wesley, 1996, Chapter 10). Yet, a minimum sized Ethernet packet equals 512 bits plus a 64 bit preamble in length. Before accounting for CSMA hold-off from a prior phase to add to any clock misalignment, there is a margin of between one half to approximately the full duration of a minimum-sized packet with respect to the master clock for device adapters of this invention to operate and still avoid collisions during assigned phases. Thus, even after accounting for CSMA hold-off from a prior phase, or by simply extending the duration of a phase as compensation, device adapters of this invention can avoid collisions and guarantee transmission deadlines in the face of significant clock misalignment.

Turning to the coarse-resolution signal, the master timing source device broadcasts the coarse-resolution signal as a frame time-stamp packet on a periodic but infrequent basis. The frame time-stamp packet provides a coarse alignment of the current time. As the fine-resolution frame-sync signal has already established a precise synchronization of frame boundaries, the coarse-resolution frame time-stamp packet can now arrive at the DAs at any time within the same frame as its transmission.

Over time, the phase of the clocks of the slave devices may start to drift from that of the master device. The arrival of the fine-resolution sync signal realigns the phases. A measurement of the amount of phase drift and the inter-arrival time of the fine-resolution sync signal also compensates for clock frequency mismatches and thereby creates a frequency compensation factor. Crystal oscillators typically have a small frequency mismatch in accordance with manufacturing tolerances. Such mismatches, usually on the order of 100 parts per million (PPM), are adjustable with a variable crystal oscillator (VXO).

As mentioned above with reference to FIG. 3, according to an exemplary embodiment of the invention, clock 1010 may be a VXO utilized as the time source for each DA 1000. In such an embodiment, the master timing device does not adjust its frequency. However, each slave device uses the frequency compensation factor of the fine-resolution sync signal from the master device to adjust the frequency of the VXO of the slave device to match the frequency of the VXO of the master timing device. By compensating for slave/master frequency mismatches, the fine-resolution sync signal need only be broadcast at infrequent intervals. This contrasts with conventional techniques that rely upon a phase-locked-loop (PLL) having a voltage-controlled oscillator (VCO). Unlike a VXO, a VCO does not incorporate a crystal oscillator. In free-running mode, a VCO may have a high degree of drift and jitter. The PLL synchronization of the prior art relies upon a periodic beat packet arriving and mixing with a local VCO on each cycle of the oscillation to lock the frequency and the phase of the local clock to the arrival time of the beat packet. However, each beat packet is subject to uncertainties in interrupt processing and network transmission delays. These non-deterministic delays introduce random jitter to each local PLL VCO clock on a per-cycle basis. The resulting precise frequency synchronization of the present invention creates a highly stable network-wide time reference and greatly reduces clock jitter as compared to prior-art PLL/beat timing source approaches.

Annex Mode

As mentioned above, in addition to Condition Mode, the network of the present invention operates in Annex Mode. With reference to FIG. 7, the network operates in Annex Mode when the device adapters 1000 of the invention coexist with prior art network interfaces called non-real-time devices (NRTDs) that are attached *directly* to the network medium 112 via network interface points 2, which devices are known as native NRTDs 101. The standard Ethernet repeater hubs 3 indicated in FIG. 7 may be replaced with specialized Ethernet repeater hubs 3a, in order to provide a master timing device and possibly a master scheduling device. As discussed in more detail below, in Annex Mode, when there is a surplus of time to meet deadlines, the transmission of real-time packets may be delayed in deference to non-real-time packets. However, collisions may be forced for non-real-time packets when a scheduled real-time packet may otherwise miss a deadline.

For example, a device adapter 1000 may determine whether there is sufficient time to transmit and deliver a real-time packet by a deadline. If so, the device adapter may defer transmission of the packet to allow a native NRTD to transmit non-real-time packets. If not, then the device adapter may become aggressive in attempting to meet a deadline. The device adapter may transmit the packet to force a collision with the native NRTD. Or it may ignore the normal 802.3 back-off algorithm and immediately retransmit after a collision without waiting. Alternatively, the device adapter may retransmit before waiting the full interpacket gap time to usurp media access; that is, the device adapter may reduce the interpacket gap and then immediately retransmit the packet. Any combination of these techniques serve to increase the priority of a device of this invention with respect to a native NRTD to guarantee timely delivery of a real-time packet transmitted by a device adapter in contention with one or more native NRTDs.

Exemplary network 110 may include a plurality of NRTDs 101 connected directly to the Ethernet network 1 through network interface points 2. Real-time devices (RTDs) 200 may be attached to device adapters 1000, which in turn are connected to network interface points 2. The Annex Mode of operation of the network 110 is advantageous, as to support a conventional NRTD it is not necessary to connect the NRTD to a device adapter 1000, which means that a conventional Ethernet network can be upgraded incrementally as additional real-time devices are installed. As illustrated in FIG. 7, NRTDs 100 are preferably attached to device adapters 1000 as the device adapters 1000 may condition the traffic generated by NRTDs 100 to reduce collisions.

An NRTD that is directly attached to a device adapter **1000** is considered a *conditioned* NRTD **100**, and an NRTD that is directly attached to the conventional Ethernet network is a *native* NRTD **101**.

A central issue with Annex Mode of the network is that the native NRTDs **101** may use a standard carrier sense multiple access collision detect (CSMA/CD) protocol and, hence, are not aware of any timing and packet-pacing mechanism used by the device adapter. The device adapters **1000** may support latency and throughput guarantees for real-time traffic by modifying the back-off protocol to ensure that packets from real-time traffic are delivered in a timely manner, which will be discussed in more detail below. However, as noted above, if a packet from a native NRTD **101** experiences several collisions, the latency suffered by the packet significantly increases as the average delay grows exponentially with the number of collisions.

An arbitration mechanism of the present invention may support a moderate traffic load from RTDs **200** without causing a significant increase in the average delay seen by native NRTDs **101**, provided that the traffic load offered by the native NRTDs **101** is sufficiently low. It is preferable for native NRTDs **101** to back off after collisions only when necessary to meet deadlines of time-sensitive signals, or when congestion caused by other native RTDs **101** is present. As a native NRTD **101** does not know when real-time traffic is being transmitted, this is not possible. Instead, the operation of the device adapters **1000** in Annex Mode prevents unnecessary collisions between device adapters **1000** and native NRTDs **101**. The device adapters **1000** accomplish this goal by deferring to native NRTD **101** traffic when possible.

The arbitration mechanism of the device adapters under Annex Mode will now be described with reference to FIG. 8. As mentioned above, a common time reference is obtained by the device adapters. Time is divided into equal length frames of duration F , and frame boundaries occur at times $t = nF$ relative to the common time reference, where n is an integer. Continuing the exemplary number of device adapters for this description, it is assumed that there are four device adapters **1000** (i.e., $N = 4$). Each frame is divided into $N + 1$ non-overlapping intervals or phases, which are labeled $p = 1, 2, 3, \dots, N + 1$. Three frames **50**, **51**, and **52** are shown, and five phases **501**, **502**, **503**, **504**, and **505** for frame **50** are shown. The first N phases are owned by respective device adapters **1000**, as indicated by numeral **56**. That is, if p satisfies $1 \leq p \leq N$, then phase p is owned by DA_p . A device adapter is not allowed to transmit in any owned phase except for the phase that its own. However, as native NRTDs **101** are oblivious to the framing structure, it is possible that native NRTDs **101** will attempt to transmit a packet at any time during a frame.

Analogous to the discussion above, phase $N + 1$ is unowned, as indicated by numeral 57, is considered as a free-access phase, allowing any device adapter 1000 to transmit during this last phase of a frame. The CSMA/CD protocol may be used during the free-access phase 57, and, therefore, collisions may occur during the free-access phase 57. Each device adapter 1000 transmitting a packet during the free-access phase 57 does so without crossing the frame boundary 58. Thus, towards the end of the free-access phase 57, a device adapter 1000 may have to refrain from transmitting a packet. Note that as native NRTDs 101 can transmit a packet at any time, a packet transmission from a native NRTD 101 may cross a frame boundary 58.

The length of the phases 501–505 may vary in each frame 50–52. At the beginning of a frame with P owned phases, there are P numbers Y_1, Y_2, \dots, Y_P known to the device adapters, such that $0 < Y_1 < Y_2 < \dots < Y_P \leq F$. The interpretation of these numbers is that if a frame begins at time t , then phase p of that frame ends at time $t + Y_p$. Letting x_1, x_2, \dots, x_P denote the lengths of phases 1, 2, 3, ..., P , in this frame, respectively, then $x_1 + x_2 + \dots + x_P = Y_p$ for all p satisfying $1 \leq p \leq P$. As discussed above before, as the length of each frame is the constant F , the length of the free-access phase is $x_{fa} = F - (x_1 + x_2 + \dots + x_P)$. In FIG. 8, it is assumed that $P=N$ for simplicity.

Exemplary arbitration mechanism utilized by the device adapters 1000 in Annex Mode are illustrated in FIG. 9a and FIG. 9b. As mentioned above, a device adapter 1000 may only transmit packets during the phase it owns or during a free-access phase. Thus, during phase p , the only devices that may transmit a packet are native NRTDs 101 and DA_p . Also mentioned above, native NRTDs 101 may use a CSMA/CD protocol. A native NRTD 101 that is deferring transmission of a packet will typically wait only IPG 19 seconds after sensing the network is idle before transmitting a packet, because if it were to wait longer, it would be at a disadvantage relative to other devices implementing the CSMA/CD protocol. As collisions are most likely to occur after the network becomes idle, a device adapter 1000 can avoid a collision with a native NRTD 101 by waiting for a time longer than the IPG 19, namely, a defer time T_{defer} 190 after sensing the network becomes idle before starting to transmit a packet. This gives native NRTDs the first opportunity to use the network when the state of the network becomes idle, as shown illustrated FIG. 9a as the possible timing of events during an owned phase.

In this example, the transmission interval of a packet 61 transmitted by a native NRTD 101 crosses the boundary 610 that defines the beginning of the phase. The DA 1000 which owns the phase has a packet 63 ready to transmit at the beginning of the phase 610, but defers (as indicated by numeral 630) to two packet transmissions 61 and 62 from native NRTDs 101 by

waiting until it senses that the network is idle for a duration of at least T_{defer} seconds. More specifically, a native NRTD 101 may attempt to transmit a packet 62 during the transmission of packet 61, but as native NRTDs follow the CSMA/CD protocol and the network is sensed busy, the native NRTD defers (as indicated by numeral 620) the transmission until the channel is sensed
5 idle for at least one IPG 19.

As the value of an inter-packet gap (IPG) 19 is less than T_{defer} , a native NRTD is able to begin the transmission of its packet 62 before the owner of the phase. In this example, the owner of the phase is first able to transmit packet 63 after T_{defer} seconds (indicated by numeral 66) following the end of the transmission of packet 62. In this example, after the owner of the phase
10 transmits packet 63, the phase owner has another packet 65 ready to transmit. Similar to above, another native NRTD 101 transmits packet 64 after deferring (indicated by numeral 640) to packet 63 by waiting for at least IPG 19 seconds of idleness. Packet 65 is not transmitted until T_{defer} seconds (indicated by numeral 67) after the end of the transmission of packet 64.

When a real-time packet needs to be transmitted in order to meet a deadline, a device
15 adapter 1000 may operate in a "aggressive mode," whereby the device adapter waits for an inter-packet gap after sensing the network becomes idle before transmitting a packet. In addition, if a device adapter is involved in a collision while in the aggressive mode, the device adapter will not back off after the collision. As native NRTDs 101 are required to back off after collisions according to conventional CSMA/CD protocol, a device adapter 100 of the present invention
20 operating in the aggressive mode can effectively monopolize the network, transmitting real-time traffic as necessary to meet deadlines. A device adapter 1000 will preferably operate in the aggressive mode only if the device adapter would otherwise be in danger of delivering real-time traffic later than required. In view of the foregoing, a device adapter 1000 attempts to minimize the chances of collision with native NRTDs 101 during the phase it owns. But when a particular
25 device adapter is otherwise in danger of transmitting packets later than their deadlines, the device adapter may enter the aggressive mode.

An alternative approach for a device adapter operating in aggressive mode is to intentionally cause collisions with native NRTDs 101 without waiting for packet transmissions to end. FIG. 9b illustrates such an example of the aggressive mode, illustrating a possible sequence
30 of events during an owned phase. The first portion of the phase operates in a similar manner to that depicted in FIG. 9a in that the transmission of a packet 61 from a native NRTD 101 overlaps with the boundary 610 that defines the beginning of the owned phase. Referring to FIG. 9b, at

the beginning of the phase, the device adapter 1000 which owns the phase has two packets 76 and 78 to transmit during the phase. However, as the phase owner is initially not in aggressive mode, the owner waits until at least T_{defer} seconds of idleness are sensed on the network before beginning the transmission of a packet. Thus, a packet 72 from a native NRTD 101 is able to transmit a
5 packet 72 after deferring (indicated by numeral 720) to packet 71, and a packet 74 from a Native NRTD 101 is transmitted after deferring (indicated by numeral 740) in the midst of a collision 73 that occurs between native NRTDs 101 after the transmission of packet 72, due to simultaneous deference (indicated by numeral 730).

After transmission of packet 74, the owner of the phase determines that it cannot wait any
10 longer 760 to transmit packets 76 and 78, and, therefore, enters the aggressive mode (indicated by numeral 7678). In this example, a native NRTD 101 defers (indicated by numeral 750) a transmission until IPG seconds after packet 74. As the owner has entered aggressive mode at this time, the owner also has the right to transmit IPG seconds after packet 74 ends transmission; and in this example a collision 75 occurs. After this collision, the native NRTD 101 backs off while
15 the owner does not back off. Therefore, the owner is able to transmit packet 76 immediately after the collision. After the transmission of packet 76 by the owner, the owner attempts to transmit packet 78, but a collision 77 occurs with a native NRTD 101 which was deferring to packet 76. The owner does not back off after this collision 77 and is able to successfully transmit packet 78 immediately after the collision.

20 Preferred Embodiment for Transmission Processing

A preferred embodiment for managing packet transmissions by a particular device adapter 1000 is described hierarchically in the flowcharts illustrated in FIG. 10a–10f. It is assumed that there are a total of N device adapters 1000 in the network, and each device adapter 1000 is assigned a unique integer address q in the range $1 \leq q \leq N$. It is also assumed that each device
25 adapter has an address p . The overall processing flow for a device adapter is illustrated in FIG. 10a. Those skilled in the art will understand that the flowcharts of FIGS. 10a–10f are for illustrated purposes and that there are multiples of functionally equivalent hardware and software implementations thereof.

The processing disclosed in FIGS. 10a–10f handles both the Annex and Conditioned
30 modes of the invention. Description of the network operating under Annex mode will be

provided initially. As discussed in more detail below, the network operating under Conditioned mode can be achieved by modification of a single parameter.

A frame begins at time $t = nF$, relative to the common time reference in the local network, where F is the frame length and n is an integer. A variable *current_time* is defined to hold the estimate of the common time reference of the device adapters. Thus, *current_time* increases at the rate of real time, and the value of *current_time* across different device adapters 1000 is synchronized to within a small error. For purposes of this description, timing errors are ignored in FIGS 10a–10f, with modifications to accommodate timing errors later being discussed below. As mentioned above, if a frame starts at time t , then phase q within that frame ends at time $t + Y_q$.

10 Transmission Processing Overview

Referring to FIG. 10a, at the beginning of a frame 5001 the processing moves to block 5010, wherein a counter named *current_phase* is initialized to 1, and a variable named *frame_start* is loaded with the value *current_time*. The value of *frame_start* thus holds the time at which the current frame began. The value of *current_phase* represents the index of the phase within a frame and is incremented accordingly as the various phases within a frame progress. 15 From block 5010, the processing moves to decision block 5020.

Within decision block 5020, the value of *current_phase* is compared to the device adapter address p . If the quantities are not equal, the processing moves to decision block 5030, where the value of *current_phase* is compared to $N+1$. In this case, if the *current_phase* is not equal to 20 $N+1$, then this indicates that the system is in an owned phase owned by another device adapter. Accordingly, in this case, the processing proceeds to the entry point 5405 of processing block 5400. The basic function of block 5400 is to silently wait for the end of the current phase. When the end of the current phase is reached, *current_phase* is incremented by 1 within the block 5400, and the exit point 5495 is reached. The details of processing block 5400 will be described in more detail below. 25

Referring back to decision block 5030, if *current_phase* = $N+1$, then this indicates that the system is in the free-access phase, and the processing accordingly moves to the entry point 5105 of processing block 5100. The function of processing block 5100, which will be described in detail later, is to manage packet transmissions according to standard Ethernet CSMA/CD 30 protocol while inhibiting transmissions at the end of the free-access phase, at which time the processing leaves block 5100 through transition 5199 to the entry point 5405 of the processing

block 5400. In this case, within block 5400, the device adapter waits for the free-access phase to end, increments *current_phase*, and exits at point 5495.

Referring back to decision block 5020, if *current_phase* = *p*, then this indicates that the beginning of phase *p*, which is owned by the device adapter, has started. Accordingly, the processing moves to the entry point 5205 of processing block 5200. The function of the processing block 5100, which is also described in more detail below, is to transmit packets during the phase owned by the device adapter. The transmissions within block 5100 will be done in a non-aggressive mode, deferring to native device adapters by using a longer inter-packet gap. If the device adapter is able to transmit the required number of real-time packets before the time that phase *p* ends, namely, at time $t+Y_p$, then the device adapter may transmit any queued non-real-time packets until the phase end time. At phase end, it then leaves the processing block 5200 through the normal exit point 5295.

If the device adapter has no packets to transmit during phase *p*, the processing moves through transition 5298 to the entry point 5405 of processing block 5400. In this case, within block 5400 the device adapter remains silent which signals the end of phase *p*, increments *current_phase*, and exits at point 5495.

If, during the course of phase *p*, the device adapter would otherwise be in danger of not being able to transmit real-time packets before their deadlines, the processing moves through transition 5299 to the entry point 5305 of processing block 5300. The function of processing block 5300 is to transmit packets during the phase owned by the device adapter operating in the aggressive mode. When the required number of real-time packets have been transmitted during phase *p*, the device adapter terminates aggressive mode and leaves the processing block 5300 through the normal exit point 5395.

Under nominal operating conditions, a particular device adapter will be able to send all the required packets during phase *p*. However, as a safety measure, the processing may move through transition 5399 to the entry point 5405 of processing block 5400. In this case, the processing within block terminates phase *p* at the required time and *current_phase* is incremented by 1 before moving to the exit point 5495 of processing block 5400.

After the termination of a phase, at exit points 5295 or 5395, the processing moves to the decision block 5020 again, so that the next phase within the frame can be processed. After termination of a phase at point 5395, the processing moves to decision block 5090. Within decision block 5090, the value of *current_phase* is compared to $N+2$. If *current_phase* = $N+2$,

this indicates the end of a free-access phase, which is the last phase of a frame. The reason that $current_phase = N+2$ in this case is that $current_phase$ is incremented from its value of $N+1$ within processing block 5400. Accordingly, if $current_phase = N+2$ within block 5090, then the processing moves through point 5099, indicating the end of a frame, to point 5010 where
 5 $current_phase$ is reinitialized to 1 and the frame processing repeats for the next frame. If $current_phase$ is not equal to $N+1$ within decision block 5090, then the processing moves to decision block 5020 so that the next phase within the current frame can be processed.

Block 5400: Waiting for Phase to End

Turning to the description of processing block 5400, reference is made to FIG. 10e. As
 10 mentioned above, the function of block 5400 is to determine when the end of the current phase occurs, and increment $current_phase$ by 1 when the phase transition occurs. From the entry point of the block 5405, the processing moves to decision block 5410 wherein the value of $current_time$ is compared to the sum of $frame_start$ and $Y_{current_phase}$. As mentioned above, by definition if a frame starts at time t , then phase q within that frame ends at time $t + Y_q$. The
 15 purpose of the decision block 5410 is therefore when the current phase ends. Accordingly, if $current_time$ is greater than or equal to the sum of $frame_start$ and $Y_{current_phase}$, then the current phase terminates and the processing moves from 5410 to 5445, where the variable $current_phase$ is incremented by 1. If $current_time$ is less than the sum of $frame_start$ and $Y_{current_phase}$, then the phase continues until time $frame_start + Y_{current_phase}$. Accordingly, the processing repeatedly
 20 reenter decision block 5410 until such time the processing moves to block 5445.

Block 5200: Transmission of Packets During Owned Phase Non-aggressively

Reference is made to FIG. 10c for discussion of the processing within block 5200. As mentioned above, the function of block 5200 is to manage the transmission of packets during the phase that a particular device adapter owns. From the entry point 5205, the processing moves to
 25 decision block 5210, wherein it is determined whether the particular device adapter has any packets to be sent during phase p which it owns. If not, the processing moves through transition 5298 to the entry point 5405 of processing block 5400, wherein the phase is terminated at the appropriate time as described above. If the particular device adapter has packets to transmit during phase p , the processing moves to block 5215. Within block 5215, the timer $idle_timer$ is
 30 set to the parameter IPG_LOCAL . Once set to a positive value, $idle_timer$ decrements at the rate of real time until it reaches zero, at which time $idle_timer$ retains the value zero until reset again.

The parameter *IPG_LOCAL* is equal to a value longer than the standard interpacket gap IPG. Within block **5200**, the device adapter attempts to avoid collisions with native NRTDs by waiting until the bus is sensed idle for *IPG_LOCAL* seconds.

Also within block **5215**, a variable *time_needed_rt* is updated. The value of *time_needed_rt* may be set equal to the maximum time it would take the device adapter to successfully transmit all the remaining real-time packets that are required to be sent during the current phase, assuming that the device adapter does so in the aggressive mode. Thus, this includes transmission times of such packets, as well as the maximum time wasted during collisions with native NRTDs, which collisions are required to cause the native NRTDs to back off and remain silent. The specification of the maximum time required by the device adapter to transmit the remaining real-time packets in the aggressive mode may be selected in accordance with a particular network implementation. The variable *time_needed_rt* is updated so that it can later be determined if the device adapter should enter the aggressive mode.

Upon leaving block **5215**, the processing moves to decision block **5220**, wherein the device adapter determines whether to send any more packets within the current phase *p*. This includes real-time packets as well as non-real-time packets. If not, the processing moves to the entry point **5405** of processing block **5400**, wherein the phase is terminated at the appropriate time as described above. If within decision block **5220** it is determined that the device adapter wishes to transmit more packets during the current phase *p*, the processing moves to decision block **5230**.

The processing may traverse the cycle of blocks **5230**, **5240**, **5245**, and **5230**, or may traverse the cycle of blocks **5230**, **5240**, **5250**, and **5220** until the time that the device adapter observes at least *IPG_LOCAL* seconds of silence on the bus, or the time it must enter the aggressive mode. Specifically, within block **5230** the sum of *current_time* and *time_needed_rt* is compared to the time when phase *p* must end by, namely, $frame_start + Y_p$. If $current_time + time_needed_rt$ is greater than $frame_start + Y_p$, then the device adapter enters the aggressive mode, and the processing moves through transition **5299** to the entry point **5305** of process block **5300**. If, on the other hand, $current_time + time_needed_rt$ is less than or equal to $frame_start + Y_p$, then the device adapter can still attempt to transmit packets in the non-aggressive mode. Accordingly in this case, the processing moves to decision block **5240**, wherein the device adapter checks the state of the bus. If the bus is not idle, the processing moves to **5245** where *idle_timer* is reset to *IPG_LOCAL*, and the processing loops back to decision block **5230**. If the bus is idle

within block 5240, then the processing moves to block 5250, where the value of *idle_timer* is compared with zero. If *idle_timer* is not equal to zero, then this indicates that the device adapter has not yet observed *IPG_LOCAL* contiguous seconds of silence, and the processing loops back to decision block 5230. If *idle_timer* is equal to zero within block 5250, then this indicates that the device adapter has observed *IPG_LOCAL* contiguous seconds of silence, and that the device adapter is now enabled to send packets. Accordingly, in this case the processing moves to block 5275, wherein a packet is transmitted.

If the device adapter has real-time packets to transmit, the device adapter will attempt to transmit such packets before attempting to transmit any of the non-real-time packets it may have to transmit.

After transmitting a packet in block 5275, the processing loops back to block 5215 in order to possibly transmit more packets. After the start of the packet transmission in block 5275, there are two possibilities. First, it is possible that the transmission collides with that of a native NRTD. In this case, the transmission is aborted after the collision is detected, and the device adapter transmits a jam signal so that all stations can reliably determine that a collision occurred. As the transmission is aborted, the value of *time_needed_rt* will not change in block 5215. If the transmission by the device adapter in block 5275 is successful, then if it was a real-time packet, the variable *time_needed_rt* is decremented in block 5215.

Block 5500: Management of Interpacket Gap Timer

FIG. 10f illustrates a process which runs on a device adapter runs on DA concurrently with the main process described in FIGS. 10a–10e. The purpose of the process is to maintain a timer variable named *IPG_timer*. As indicated in the figure, the state of the bus is continuously monitored in decision block 5510. Whenever activity is sensed on the bus, the timer *IPG_timer* is set to a predetermined interpacket gap (IPG), which may be the value of the standard interpacket gap in the Ethernet access protocol. While positive, the value of *IPG_timer* is decremented at the rate of real-time until a value of zero is reached. Once zero is reached, *IPG_timer* remains constant until reset to a positive value. Thus, if *IPG_timer* equals zero at any point in time, then this indicates that the device adapter has observed silence for at least the past IPG seconds relative to the current time.

Block 5300: Transmission of Real-Time Packets in Aggressive Mode

The process block 5300 is described with reference to FIG. 10d. As mentioned above, the function of block 5300 is to control the timing of the transmission of real-time packets by the device adapter in the aggressive mode during phase p . Upon entering the block through entry point 5305, the processing begins at decision block 5310, where the value of IPG_timer is compared with zero. If IPG_timer is not equal to zero, then the processing loops back to decision block 5310. The processing does not break from decision block until IPG_timer is equal to zero. When IPG_timer is equal to zero, this indicates that IPG seconds of silence have elapsed, and accordingly a packet transmission can start. Accordingly, in this case the processing moves to block 5320.

Within decision block 5320, a variable tx_time_next is referenced. This variable holds the transmission time of the next real-time packet to be transmitted during the current phase. The sum of $current_time$ and tx_time_next is compared to $frame_start + Y_p$. If $current_time + tx_time_next$ is greater than $frame_start + Y_p$, then transmission of the next real-time packet that requires transmission in the current phase would cause the duration of phase to extend beyond time $t + Y_p$, which violates the constraint on the ending time of phase p . Accordingly, in this case, the processing moves through transition 5399 to the entry point 5405 of block 5400, so that the current phase will terminate as required. The transition 5399 is included as a safety valve to ensure that phase p terminates by the required time and will not be traversed under nominal conditions. If $current_time + tx_time_next$ is less than or equal to $frame_start + Y_p$, then there is sufficient time to transmit the next real-time packet within the current phase p , and the processing moves to Block 5345, wherein a real time packet is transmitted.

After the packet has begun transmission in 5345, the processing moves to decision block 5340. There are two possibilities for the fate of the packet transmission. If a collision occurs, the transmission is aborted as soon as the collision is detected, and a JAM signal is sent, as in standard Ethernet access protocol. In this case, the processing moves from 5340 back to decision block 5310, so that the packet can be retransmitted. The device adapter does not back off after a collision but instead may try to transmit after waiting only for the bus to remain silent for the standard interpacket gap IPG. If the transmission in block 5345 completes successfully, then the processing moves from block 5340 to decision block 5350.

Within decision block 5350, the device adapter determines whether there are more real-time packets remaining to be transmitted during the current phase p . If so, the processing loops back to decision block 5310, so that the remaining real-time packets may be transmitted. If not

the processing proceeds to the entry point 5405 of block 5400, so that the current phase will terminate as required.

Block 5100: Transmission of Packets in Free-Access Phase

Referencing FIG. 10b, an exemplary implementation of process block 5100 is illustrated.

5 As mentioned above, the function of block 5100 is to transmit packets during the free-access phase according to standard CSMA/CD protocol of Ethernet, while inhibiting transmissions at the end of the phase. The processing enters decision block 5110 after passing through the entry point 5105.

10 Within decision block 5110, a variable *tx_time_next* is referenced. This variable holds the transmission time of the next packet to be transmitted during the current phase, and is equal to zero if there is no packet currently queued. The sum of *current_time* and *tx_time_next* is compared to *frame_start* + Y_{N+1} . As described above, the free-access phase within the current frame ends at time *frame_start* + Y_{N+1} . Accordingly, if *current_time* + *tx_time_next* is greater than or equal to *frame_start* + Y_{N+1} , then the next packet cannot be successfully transmitted
15 within the current free access phase, and the processing moves through transition 5199 to the entry point 5405 of block 5400, where the free-access phase will be terminated as appropriate. If *current_time* + *tx_time_next* is less *frame_start* + Y_{N+1} , then the processing moves to decision block 5120.

20 Once the processing moves to decision block 5120, it is allowable for the device adapter to attempt transmission of a packet. However, it must wait for at least IPG seconds of silence before doing so, and back off from any previous collisions that may have already been suffered by the packet. Accordingly, within decision block 5120, the device adapter tests to determine whether *IPG_timer* is equal to zero and *backoff_timer* is equal to zero. If so, the device adapter has observed IPG seconds of silence and is through backing off from any previous collisions that
25 may have occurred, and thus proceeds to decision block 5130. If not, the processing loops back to decision block 5110.

Within decision block 5130, the device adapter determines whether there is a packet waiting to be transmitted. If not, the processing loops back to decision block 5110. If so, the processing moves to 5140 and the packet is transmitted.

30 After the packet has begun transmission in block 5140, the processing moves to decision block 5150. There are two possibilities for the fate of the packet transmission. If a collision occurs, the transmission is aborted as soon as the collision is detected, and a JAM signal is sent,

as in the standard Ethernet access protocol. In this case the processing moves from 5150 to block 5170. Within block 5170, the timer *backoff_timer* is set to a random retransmission delay as in the standard truncated binary exponential back-off algorithm within the Ethernet protocol. In particular, if a packet has experienced k collisions, then *backoff_timer* is set to iT , where T is the slot time and i is a random integer in the range $0 \leq i < 2^m$ and $m = \min\{k, 10\}$. After a packet has experienced 16 collisions, the packet is discarded. Note that as long as the timer *backoff_timer* remains positive, *backoff_timer* decrements at the rate of real time until it reaches zero. When zero is reached, *backoff_timer* retains the value of zero until reset to a positive value. Thus, when *backoff_timer* = 0, the device adapter is through backing off from any previous collisions that may have occurred. If the transmission in block 5140 was successful, then the processing moves from block 5140 to block 5160, where the *backoff_timer* is set to zero. From either block 5160 or block 5170, the processing loops back to decision block 5110 so that the next transmission or retransmission can proceed if possible within the free-access phase.

During the free-access phase, it may be preferable for the device adapter 1000 to use a longer interpacket gap, *IPG_LOCAL*, in order to avoid collisions with other device adapters 1000 and native NRTDs, thereby surrendering priority to native NRTDs. The necessary modifications to process block 5100 in order to implement this will be apparent to someone skilled in the art.

Transmission Processing for Conditioned Mode

If the network is configured in Conditioned mode rather than Annex mode, then no collisions are possible during owned phases, so that it is unnecessary for a particular device adapters to defer by using a longer interpacket gap within the phase p that it owns. In this case, the processing can be optimized by setting the parameter *IPG_LOCAL*, defined within processing block 5200, to the standard interpacket gap IPG. In the conditioned mode, the process block 5300 will not be entered under nominal conditions. Preferably, a device adapter 1000 can automatically detect whether or not the network is configured in Conditioned mode or Annex mode by detecting collisions during owned phases, for example, and set the value of *IPG_LOCAL* accordingly.

Universal Ethernet Repeater Hub with Prior Art Ethernet Ports

In addition to the Annex mode described above, the present invention provides alternative methods and apparatus for configuring both real-time devices (RTDs) 200 and non-real-time device (NRTDs) 100 that are connected to a device adapter (DA) 1000 (see FIG. 7) with

conventional non-real-time devices (NRTDs) **101** into a network. In this regard, an exemplary embodiment of a universal Ethernet repeater hub **3b** with prior art Ethernet ports in accordance with the present invention is illustrated in FIG. 11. Exemplary universal repeater hub **3b**, which may function as either a master timing device or a master scheduling device, eliminates collisions
5 between native NRTDs **101** and device adapters. This is accomplished by determining whether a packet originates from a prior art device or from a device connected to a device adapter **1000**, as discussed in detail below.

Universal repeater hub **3b** includes a plurality of conventional Ethernet repeater hubs **3**, preferably two repeater hubs as shown. One of the Ethernet repeater hubs **3** connects to native
10 NRTDs **101**, via Ethernet a plurality of ports **1036b–1036g**, and the other Ethernet repeater hub **3** connects to device adapters **1000** via a plurality of ports **1034b–1034g**. As there are two separate Ethernet repeater hubs **3**, packet transmissions from both the device adapters **1000** and the connected native NRTDs **101** may be buffered, which is discussed in detail below. Exemplary universal repeater hub **3b** includes a processor **1030** connected to the conventional Ethernet
15 repeater hubs **3** via respective Ethernet interfaces **1032a** and **1032b**. Accordingly, processor **1030** can independently communicate with devices attached to either of the Ethernet repeater hubs **3**.

Exemplary processor **1030** operates analogously as a device adapter **1000** on behalf of the attached native NRTDs **101**. In particular, packets received from a native NRTD **101** may be
20 temporarily stored in a memory device **1035** connected to the processor **1030** before being forwarded through port **1034a** of the Ethernet repeater hub connected with device adapters **1000**. Such forwarding, through Ethernet interface **1032a**, is preferably carried out in accordance with the condition mode of the arbitration mechanism described above. Conversely, packets received from device adapters **1000** are forwarded through port **1036a** of the Ethernet repeater hub
25 connected to the native NRTDs **101**. Packet transmissions on Ethernet interface **1032b** are preferably carried out in accordance with standard CSMA/CD protocol.

Regarding buffering, a real-time packet received at one of the ports **1034** of a first of the repeater hubs **3** (i.e., the repeater hub dedicated to the device adapters) and addressed to a device connected to another one of the ports **1034** of the first repeater hub **3** is not buffered but is rather
30 repeated out of all the ports **1034** of the first repeater hub **3** to transmit the packet to the addressed device. However, if a real-time packet received at one of the ports **1034** of the first repeater hub **3** is addressed to a device connected to one of the ports **1036** of a second of the

repeater hubs **3** (i.e., the repeater hub dedicated to conventional NRTDs), then such a packet is buffered by the processor **1030** until the second Ethernet repeater hub is idle as per the CSMA/CD protocol.

In addition, a non-real-time packet received at one of the ports **1036** of the second repeater hub **3** and addressed to a device connected to one of the ports **1034** of the first repeater hub may be buffered by the processor **1030** until the next free-access phase, during which time such a packet is repeated to each of the ports **1034** to transmit the packet to the addressed device. During free-access phases, the repeater hubs **3** essentially act as a single hub, with each incoming packet transmitted directly to the addressed device without the need to buffer the packets, for example, by broadcasting the incoming packets to each of the ports.

Exemplary universal Ethernet repeater hub **3b** may also include a clock source **1031** so that the universal repeater hub **3b** can act as a master timing source as described above. Moreover, as described above, the processor **1030** can also serve as the master scheduling device. In addition, uplink ports **1033a** and **1033b** of the Ethernet repeater hubs **3** can be used to connect with additional repeater hubs (not shown) to provide more ports for connecting with additional device adapters and native NRTDs **101**.

Universal Ethernet Repeater Hub with Configurable Ports

Another exemplary embodiment of the universal Ethernet repeater hubs of the present invention is illustrated in FIG. **12** and indicated by reference numeral **3c**. Exemplary universal Ethernet repeater hub **3c** includes a plurality (e.g., a pair) of conventional Ethernet repeater hubs **3** each with a plurality of ports. In contrast to the embodiment of the universal repeater hub **3b** shown in FIG. **11** in which two sets of ports (i.e., one for connected to device adapters and one for connecting to native NRTDs) are provided, exemplary universal repeater hub **3c** shown in FIG. **12** includes one set or type of port configured for connecting to either a device adapter **1000** or a native NRTD **101**. The architecture of exemplary universal Ethernet repeater hub **3c** shown in FIG. **12** is analogous to exemplary universal Ethernet repeater hub **3b** shown in FIG. **11** except for the inclusion of a plurality of ports **1045** respectively connected to a plurality of switches **1050**.

Each of the ports **1045** is connected to either a device adapter **1000** or a conventional NRTD **101**. The switches **1050** select which of the Ethernet repeater hubs **3** an attached device is connected to by determining whether a particular port **1045** is connected to a device adapter **1000**

or a conventional NRTD 101. The switches 1050 may be controlled manually but are preferably controlled automatically. Manual control may be accomplished with mechanical switches. The automatic control of the switches 1050 may be accomplished electrically. Such electrical control may require additional hardware (not shown) to determine which type of device a port is attached
5 to. The requirements of such additional hardware will become apparent to someone skilled in the art.

In accordance with the present invention, each of the switches 1050 in conjunction with the processor 1030 determines whether the port 1045 corresponding thereto is connected to either a device adapter 1000 or a conventional NRTD 101. If a port 1045 is connected to a
10 device adapter 1000, then all packets received at that port are directed to the first of the repeater hubs 3 by the corresponding switch 1050. Conversely, if a port 1045 is connected directly to a conventional NRTD 101, then all packets received at that port are directed to the second of the repeater hubs 3 by the corresponding switch 1050. The switches 1050 may determine whether a port 1045 is connected to a device adapter 1000 by, for example, having the processor 1030 send
15 a timing signal or other special packet from the clock source 1031 to the device connected thereto as described above. If an appropriate response signal is returned, then the device connected to that particular port is a device adapter; if no signal is returned, then the device connected to that port is a conventional NRTD.

Dynamic Operation

20 In the arbitration mechanisms described above, each device adapter 1000 in the network owned a phase in every frame. If a device adapter 1000 is not actively carrying any real-time traffic (e.g., a telephone is on hook), the device adapter may be desirable to de-allocate the phase owned by this inactive device adapter. Using non-real-time packets, the device adapters 1000 may coordinate to agree on how many phases are in each frame and on the ownership of the
25 phases. Each device adapter 1000, active or not, may be periodically required to transmit a packet announcing its existence. Each device adapter 1000 may then maintain a table of device adapter that have announced their existence, which entries expire if a corresponding announcement is not heard before a timer expires. The addresses of the device adapters in this table then define a natural ordering between the device adapters 1000 in the network, which can
30 be used to define the order of ownership of owned phases during a frame, and to define the master scheduling device.

In addition to Ethernet networks, the principles of the present invention may be applied in conjunction with networks operating in accordance time division multiple access (TDMA) or synchronous optical network (SONET) protocols. For example, asynchronous transfer mode SONET (ATM/SONET) networks transmit large frames with predetermined fixed time slots at regular intervals. A SONET frame may be received on an OC3 line by a device adapter 1000 and particular cells from the SONET frame may be converted into or configured as a packet in an assigned phase of the present invention. For example, specific time slots of the SONET frame that have been assigned to a particular virtual channel may be assigned to respective device adapters from a remote Conditioned sub-network (i.e., a network connected to a device adapter 1000 of the invention). Accordingly, the device adapters 1000 of the present invention are not only compatible with conventional network hardware but also provide compatibility across network protocols.

Those skilled in the art will understand that the embodiments of the present invention described above exemplify the present invention and do not limit the scope of the invention to these specifically illustrated and described embodiments. The scope of the invention is determined by the terms of the appended claims and their legal equivalents, rather than by the described examples. In addition, the exemplary embodiments provide a foundation from which numerous alternatives and modifications may be made, which alternatives and modifications are also within the scope of the present invention as defined in the appended claims.

CLAIMS

What is claimed is:

- 1 1. A network for communicating packets of data, comprising:
2 a network medium;
3 a plurality of devices for generating packets of data for transmission on said network
4 medium; and
5 a plurality of device adapters each including:
6 a device interface for connecting to one of said devices and for receiving said packets
7 generated thereby;
8 a network interface for connecting to said network medium; and
9 a processor connected to said interfaces for transmitting said packets received at said
10 device interface to said network interface;
11 said plurality of device adapters creating a frame of time, said frame being substantially
12 synchronized in said plurality of device adapters and repeating periodically, said frame including a
13 plurality of phases;
14 each of said device adapters having one of said phases assigned thereto and transmitting
15 said packets received at said device interface to said network medium during said phase assigned
16 thereto; and
17 said plurality of phases including a free-access phase during which each of said device
18 adapters is able to transmit said packets.
- 1 2. A network as claimed in claim 1 wherein said plurality of phases includes a guard
2 phase during which none of said device adapters is able to transmit said packets.
- 1 3. A network as claimed in claim 1 wherein each of said phases has a predetermined
2 length of time.
- 1 4. A network as claimed in claim 3 wherein said length of time of each said phase is
2 variable.

1 **5.** A network as claimed in claim **3** wherein said length of time of each said phase varies
2 proportionally with an amount of said data in said packets received at said device interface of a
3 respective said device adapter.

1 **6.** A network as claimed in claim **1** wherein said processor of each said device adapter
2 inserts an END signal in a last packet transmitted from said packets received at said device
3 interface to signify an end of said phase assigned thereto.

1 **7.** A network as claimed in claim **1** wherein said plurality of devices includes a real-time
2 device for generating real-time packets of data.

1 **8.** A network as claimed in claim **7** wherein said plurality of devices includes a
2 non-real-time device for generating non-real-time packets of data.

1 **9.** A network as claimed in claim **8** wherein said device adapters transmitting said
2 real-time packets during said phase respectively assigned thereto and said non-real-time packets
3 during said free-access phase.

1 **10.** A network as claimed in claim **9** wherein said device adapters transmit said non-real-
2 time packets during said phase respectively assigned thereto in the absence of said real-time
3 packets.

1 **11.** A network as claimed in claim **1** wherein said plurality of devices includes a native
2 non-real-time device connected to said network medium and for generating non-real-time packets
3 of data.

1 **12.** A network as claimed in claim **11** wherein said native non-real-time device is
2 able to transmit said non-real-time packets during any of said plurality of phases.

1 **13.** A network as claimed in claim **1** wherein each of said device adapters includes a clock.

1 **14.** A network as claimed in claim **13** wherein said plurality of device adapters includes a
2 master device adapter for providing a signal for synchronizing said clocks of said plurality of
3 device adapters.

1 **15.** A network as claimed in claim **14** wherein said signal is transmitted periodically.

1 **16.** A network as claimed in claim **14** wherein said clocks drift over time;
2 said signal being transmitted as necessary to correct for said drift.

1 **17.** A device adapter for regulating traffic in a network, the broadcast network
2 including devices for generating packets of data and a network medium for carrying the packets,
3 said device adapter comprising:

4 a device interface for connecting to one of the devices and for receiving packets of data
5 generated thereby;

6 a network interface for connecting to the network medium; and

7 a processor connected to said interfaces for receiving packets from said device interface
8 and for transmitting packets to the network interface;

9 said device adapter having a time reference which is substantially synchronized with that
10 of other said device adapters connected to the broadcast network, said time reference defining a
11 frame of time, said frame including a plurality of phases, said frame repeating periodically; said
12 plurality of phases including a free-access phase;

13 said device adapter having one of said phases being assigned thereto; and

14 said processor of said device adapter transmitting packets received at said device interface
15 during said phase assigned thereto and during said free-access phase.

1 **18.** A device adapter as claimed in claim **17** wherein said plurality of phases
2 includes a guard phase during which said processor unable to transmit packets received at said
3 device interface.

1 **19.** A device adapter as claimed in claim **17** further comprising a memory connected to
2 said processor for storing packets prior to transmission.

1 **20.** A device adapter as claimed in claim 17 wherein said processor inserts an END signal
2 in a last packet transmitted from packets received at said device interface to signify an end of said
3 phase assigned thereto.

1 **21.** A device adapter as claimed in claim 17 wherein said device interface is connected to a
2 real-time device for generating real-time packets of data.

1 **22.** A device adapter as claimed in claim 21 further comprising a second device interface
2 for connecting to a non-real-time device for generating non-real-time packets of data.

1 **23.** A device adapter as claimed in claim 22 wherein said processor transmits said real-
2 time packets during said phase assigned thereto and said non-real-time packets during said free-
3 access phase.

1 **24.** A device adapter as claimed in claim 23 wherein said processor transmits said non-
2 real-time packets during said phase respectively assigned thereto in the absence of said real-time
3 packets.

1 **25.** A device adapter as claimed in claim 17 further comprising a clock.

1 **26.** A device adapter as claimed in claim 25 wherein said processor receives a signal on
2 said network interface for synchronizing said clock with that of other said device adapters
3 connected to the broadcast network.

1 **27.** A device adapter as claimed in claim 25 wherein said processor transmits a
2 signal on said network interface for synchronizing said clocks of other said device adapters
3 connected to the broadcast network.

1 **28.** A device adapter as claimed in claim 27 wherein said processor transmits said
2 signal periodically.

1 **29.** A device adapter as claimed in claim 27 wherein said processor transmits said signal at
2 a predetermined interval to compensate for drift in said clocks.

1 **30.** A method for regulating traffic in a network including devices for generating packets
2 of data, a network medium for carrying the packets, and a plurality of device adapters connected
3 between the devices and the network medium, said method comprising the steps of:

4 defining a common time reference for the device adapters, said common time reference
5 including a frame of time having a plurality of phases, each of said phases being assigned to one of
6 the device adapters, said plurality of phases including a free-access phase;

7 allowing a device adapter to transmit packets during said phase assigned thereto and
8 during said free-access phase; and

9 cyclically repeating said frame.

1 **31.** A method as claimed in claim **30** further comprising the steps of:

2 defining a guard phase in said plurality of phases of said frame; and

3 preventing each of the device adapters from transmitting packets during said guard phase.

1 **32.** A method as claimed in claim **30** further comprising the steps of:

2 defining each of said plurality of phases to have a length of time; and

3 varying said lengths of time in proportion to a number of packets to be transmitted
4 respectively by the device adapters.

1 **33.** A method as claimed in claim **30** further comprising the step of:

2 inserting an END signal in a last packet to be transmitted by one of the device adapters to
3 end of the phase assigned thereto.

1 **34.** A method as claimed in claim **30** further comprising the step of:

2 synchronizing said device adapters.

1 **35.** A method as claimed in claim **34** wherein said synchronizing step comprises the step
2 of:

3 transmitting a signal to each of the device adapters.

1 **36.** A method as claimed in claim **35** wherein said signal is transmitted periodically.

1 **37.** A method as claimed in claim **35** wherein said signal is transmitted at a predetermined
2 interval to compensate for drift in clocks of the device adapters.

1 **38.** A method as claimed in claim **30** wherein the network includes a real-time device
2 connected to a device adapter for generating real-time packets and a non-real-time device
3 connected directly to the network medium for generating non-real-time packets, said method
4 further comprising the step of:

5 allowing the non-real-time device to transmit the non-real-time packets during any of the
6 phases.

1 **39.** A method as claimed in claim **38** further comprising the step of:

2 allowing a device adapter to transmit a real-time packet to force a collision with the non-
3 real-time packet when there is not sufficient time for said real-time packet to meet a delivery
4 deadline.

1 **40.** A method as claimed in claim **39** wherein interpacket gaps are defined between said
2 phases, said method further comprising the step of:

3 reducing said interpacket gap when a collision occurs; and
4 retransmitting said real-time packet.

1 **41.** A network for communicating packets of data, comprising:

2 a network medium;

3 a plurality of devices for generating packets of data for transmission on said network
4 medium; and

5 a plurality of device adapters each including:

6 a device interface for connecting to one of said devices and for receiving said packets
7 generated thereby;

8 a network interface for connecting to said network medium; and

9 a processor connected to said interfaces for transmitting said packets received at said
10 device interface to said network interface;

11 said plurality of device adapters creating a frame of time, said frame being substantially
12 synchronized in said plurality of device adapters and repeating periodically, said frame including a
13 plurality of phases;

14 each of said device adapters having one of said phases assigned thereto and transmitting
15 said packets received at said device interface to said network medium during said phase assigned
16 thereto; and

17 said plurality of phases including a guard phase during which none of said device adapters
18 is able to transmit said packets.

1 42. A network as claimed in claim 41 wherein said plurality of phases includes a free-
2 access phase during which each of said device adapters is able to transmit said packets.

1 43. A network for communicating packets of data, comprising:

2 a network medium;

3 a plurality of devices for generating packets of data for transmission on said network
4 medium; and

5 a plurality of device adapters each including:

6 a device interface for connecting to one of said devices and for receiving said packets
7 generated thereby;

8 a network interface for connecting to said network medium; and

9 a processor connected to said interfaces for transmitting said packets received at said
10 device interface to said network interface;

11 said plurality of device adapters creating a frame of time, said frame repeating periodically
12 and including a plurality of phases;

13 each of said device adapters having at least one of said phases assigned thereto and
14 transmitting said packets received at said device interface to said network medium during said
15 phase assigned thereto;

16 said plurality of phases including a free-access phase during which each of said device
17 adapters is able to transmit said packets; and

18 said plurality of device adapters including a master timing device for synchronizing said
19 frame in said plurality of device adapters.

1 **44.** A network as claimed in claim **43** wherein said master timing device synchronizes said
2 frame in said plurality of device adapters by sending a fine-resolution frame-sync signal to at least
3 one other said device adapter.

1 **45.** A network as claimed in claim **44** wherein said master timing device compensates for a
2 propagation delay between said master timing device and at least one other said device adapter.

1 **46.** A network as claimed in claim **45** wherein said master timing device determines said
2 propagation delay by measuring a round-trip delay of said frame-sync signal between said master
3 timing device and said other device adapter.

1 **47.** A network as claimed in claim **46** wherein said master timing device estimates a one-
2 way delay between said master timing device and said other device adapter by dividing said
3 round-trip delay by two.

1 **48.** A network as claimed in claim **47** wherein said master timing device compensates for
2 said propagation delay by subtracting said one-way delay from a phase offset within a frame.

1 **49.** A network as claimed in claim **44** wherein said master timing device synchronizes said
2 frame by transmitting a coarse-resolution frame time-stamp packet to at least one other device
3 adapter to align current time.

1 **50.** A network as claimed in claim **43** wherein said master timing device compensates for a
2 propagation delay between said master timing device and at least one other device adapter.

1 **51.** A network as claimed in claim **50** wherein said master timing device determines said
2 propagation delay by receiving a sync-verification signal from said at least one other device
3 adapter and measuring a time offset between said at least one other device adapter and said
4 master timing device.

1 **52.** A network as claimed in claim **51** wherein said master timing device compensates for
2 said propagation delay by transmitting a correction offset value based on said time offset to said at
3 least one other device adapter.

1 **53.** A network as claimed in claim **43** wherein each of said plurality of device adapters
2 includes a crystal oscillator as a time source.

1 **54.** A network as claimed in claim **53** wherein said master timing device synchronizes said
2 frame in said plurality of device adapters by sending a frame-sync signal to at least one other said
3 device adapter to synchronize the frequency of said crystal oscillator thereof.

1 **55.** A network as claimed in claim **43** wherein each of said device adapters has a media
2 access control (MAC) address;
3 said master timing device having the lowest MAC address of said plurality of device
4 adapters.

1 **56.** A network as claimed in claim **43** wherein said plurality of device adapters includes an
2 alternate master timing device which functions as said master timing device when said device
3 connected to said master timing device goes offline.

1 **57.** A network for communicating packets of data, comprising:
2 a network medium;
3 a universal repeater hub including a plurality of ports and a plurality of Ethernet repeater
4 hubs, each of said ports being connected to one of said Ethernet repeater hubs;
5 a plurality of devices for generating packets of data for transmission on said network
6 medium; and
7 a plurality of device adapters each including:
8 a device interface for connecting to one of said devices and for receiving said packets
9 generated thereby;
10 a network interface for connecting to one of said ports of said universal repeater hub
11 via said network medium; and
12 a processor connected to said interfaces for transmitting said packets received at said
13 device interface to said network interface;
14 said plurality of device adapters creating a frame of time, said frame repeating periodically
15 and including a plurality of phases;

16 each of said device adapters having at least one of said phases assigned thereto and
17 transmitting said packets received at said device interface to said network medium during said
18 phase assigned thereto;

19 said plurality of phases including a free-access phase during which each of said device
20 adapters is able to transmit said packets; and

21 at least one of said devices connected directly to one of said ports of said universal
22 repeater hub; and

23 each of said ports of said universal repeater hub connected to one of said device adapters
24 being connected to a first of said Ethernet repeater hubs, and each of said ports of said universal
25 adapter connected directly to one of said devices being connected to a second of said Ethernet
26 repeater hubs.

1 **58.** A network as claimed in claim 57 wherein said universal repeater hub includes a
2 plurality of switches respectively connected to said plurality of ports;

3 each of said switches for connecting a corresponding said port connected to one of said
4 device adapters to said first of said Ethernet repeater hubs and for connecting a corresponding
5 said port connected to directly to one of said devices to said second of said Ethernet devices.

1 **59.** A network as claimed in claim 58 wherein said universal repeater hub includes a
2 processor and a clock source;

3 said processor sending a timing signal from said clock source to each of said ports to
4 determine whether said port is connected to one of said device adapters or connected directly to
5 one of said devices.

1 **60.** A universal repeater hub for connecting a plurality of real-time devices and non-real-
2 time devices into a network, the network including a plurality of device adapters connected to the
3 real-time devices, said universal repeater hub comprising:

4 a plurality of ports each connected to either a device adapter or a non-real-time device;
5 and

6 a plurality of Ethernet repeater hubs;

7 each of said ports connected to a device adapter being connected to a first of said Ethernet
8 repeater hubs, and each of said ports connected to a non-real-time device being connected to a
9 second of said Ethernet repeater hubs.

1 **61.** A universal repeater hub as claimed in claim **60** further comprising a plurality of
2 switches respectively connected to said plurality of ports and to each of said Ethernet repeater
3 hubs;

4 each of said switches for connecting a corresponding said port to either said first Ethernet
5 repeater hub or said second Ethernet repeater hub.

1 **62.** A universal repeater hub as claimed in claim **61** further comprising a processor
2 connected to each of said Ethernet repeater hubs and a clock source connected to said processor.

1 **63.** A universal repeater hub as claimed in claim **62** wherein said processor sends a timing
2 signal from said clock source to each of said ports to determine whether each of said ports is
3 connected to a device adapter or to a non-real-time device;

4 said processor receiving a return signal if a port is connected to a device adapter.

1 **64.** A universal repeater hub as claimed in claim **63** wherein each of said switches connects
2 a corresponding said port to said first Ethernet repeater hub if said port is connected to a device
3 adapter.

1 **65.** A method for regulating traffic in an Ethernet network including real-time devices,
2 non-real-time devices, a network medium, a plurality of device adapters, and a universal repeater
3 hub, said universal repeater hub including a plurality of ports respectively connected to a plurality
4 of switches which are connected to at least a pair of Ethernet repeater hubs, at least one of said
5 ports being connected to one of said device adapters and at least one of said ports being
6 connected to one of said non-real-time devices, said method comprising the steps of:

7 determining whether each of said ports of said universal repeater hub is connected to a
8 device adapter or to a non-real time device;

9 directing packets received at a port connected to a device adapter to a first of said
10 Ethernet repeater hubs; and

11 directing packets received at a port connected to a conventional non-real time device to a
12 second of said Ethernet repeater hubs.

1 **66.** A method as claimed in claim **65** wherein said determining step comprises the step of:

2 sending a timing signal to each of said ports; and
3 receiving a return signal from each of said ports connected to a device adapter.

1 67. A device adapter for regulating traffic in a broadcast network, the broadcast network
2 including devices for generating packets of data and a network medium for carrying the packets,
3 said device adapter comprising:

4 a device interface for connecting to one of the devices and for receiving packets of data
5 generated thereby;

6 a network interface for connecting to the network medium; and

7 a processor connected to said interfaces for receiving packets from said device interface
8 and for transmitting packets to the network interface;

9 said device adapter having a time reference, said time reference defining a frame of time,
10 said frame including a plurality of phases, said frame repeating periodically; said plurality of
11 phases including a free-access phase;

12 said device adapter having one of said phases being assigned thereto; and

13 said processor of said device adapter transmitting packets received at said device interface
14 during said phase assigned thereto and during said free-access phase.

15 said device adapter being capable of receiving a signal for synchronizing said time
16 reference with other said device adapters connected to the broadcast network.

1 68. A device adapter as claimed in claim 67 wherein said device adapter is capable of
2 transmitting a signal to other said device adapters connected to the broadcast network for
3 synchronizing said time references other said device adapters connected to the broadcast network.

1 69. A method for regulating traffic in an Ethernet network including real-time devices,
2 non-real-time devices, a network medium, and a plurality of device adapters connected between
3 the devices and the network medium, each of the device adapters including a clock, said method
4 comprising the steps of:

5 defining a common time reference for the device adapters, said common time reference
6 including a frame of time having a plurality of phases, each of said phases being assigned to one of
7 the device adapters, said plurality of phases including a free-access phase;

8 allowing a device adapter to transmit packets during said phase assigned thereto and
9 during said free-access phase;

10 designating one of said device adapters as a master timing device; and
11 synchronizing the clocks of the remaining device adapters with said master timing device.

1 70. A method as claimed in claim 69 wherein said synchronizing step comprises the step
2 of:
3 sending a fine-resolution frame-sync signal to at least one other device adapter.

1 71. A method as claimed in claim 70 said synchronizing step further comprises the step of:
2 compensating for a propagation delay between said master timing device and said other
3 device adapter.

1 72. A method as claimed in claim 71 wherein said compensating step comprises the step
2 of:
3 determining said propagation delay by measuring a round-trip delay of said frame-sync
4 signal between said master timing device and said other device adapter

1 73. A method as claimed in claim 72 wherein said determining step comprises the step of:
2 estimating a one-way delay between said master timing device and said other device
3 adapter by dividing said round-trip delay by two.

1 74. A method as claimed in claim 72 wherein said compensating step comprises the step
2 of:
3 subtracting said one-way delay from a phase offset within a frame of said other device
4 adapter.

1 75. A method as claimed in claim 69 wherein said synchronizing step comprises the step
2 of:
3 transmitting a coarse-resolution frame time-stamp packet to at least one other device
4 adapter to align current time of said other device adapter.

1 76. A method as claimed in claim 69 further comprising the step of:
2 compensating for a propagation delay between said master timing device and at least one
3 other device adapter.

1 **77.** A method as claimed in claim 76 wherein said compensating step comprises the step
2 of:

3 determining said propagation delay with said master timing device by receiving a sync-
4 verification signal from said other device adapter and measuring a time offset between said at least
5 one other device adapter and said master timing device.

1 **78.** A method as claimed in claim 77 wherein compensating step comprises the step of:
2 transmitting a correction offset value based on said time offset to said other device
3 adapter.

1 **79.** A method as claimed in claim 69 wherein each of the device adapters includes a crystal
2 oscillator as a time source, said synchronizing step comprising the step of:
3 sending a frame-sync signal to at least one other said device adapter to synchronize the
4 frequency of said crystal oscillator thereof.

1 **80.** A method as claimed in claim 69 wherein each of the device adapters has a media
2 access control (MAC) address, said designating step comprising the step of:
3 designating said master timing device as the device adapter having the lowest MAC
4 address of the plurality of device adapters.

1 **81.** A method as claimed in claim 69 further comprising the step of:
2 designating an alternate master timing device which functions as said master timing device
3 when a device connected to said master timing device goes offline.

1 **82.** A method as claimed in claim 69 wherein said allowing step comprises the step of:
2 accessing the network medium with a network protocol of carrier sense multiple access
3 with collision detect (CSMA/CD).

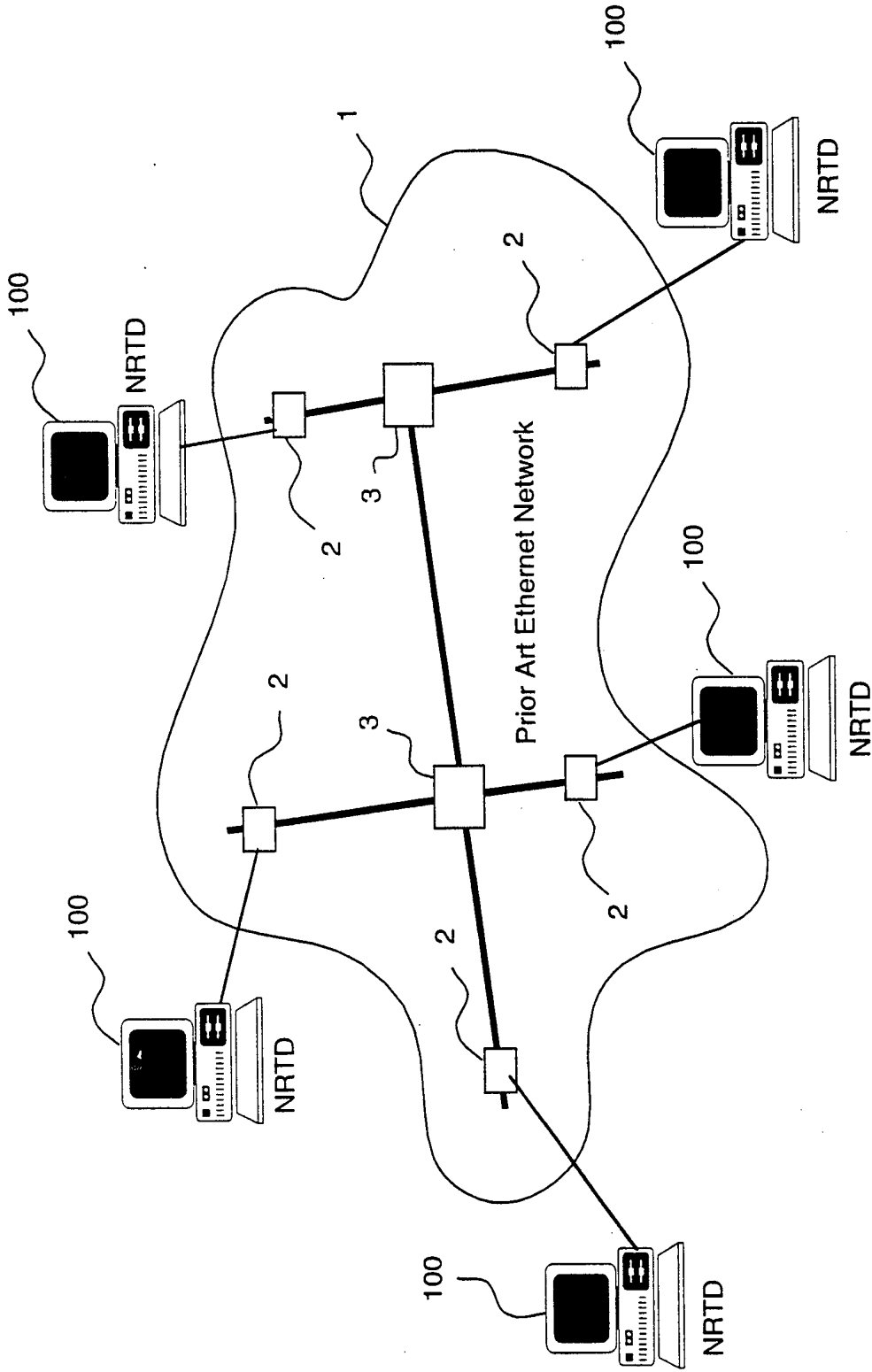

FIG. 1a

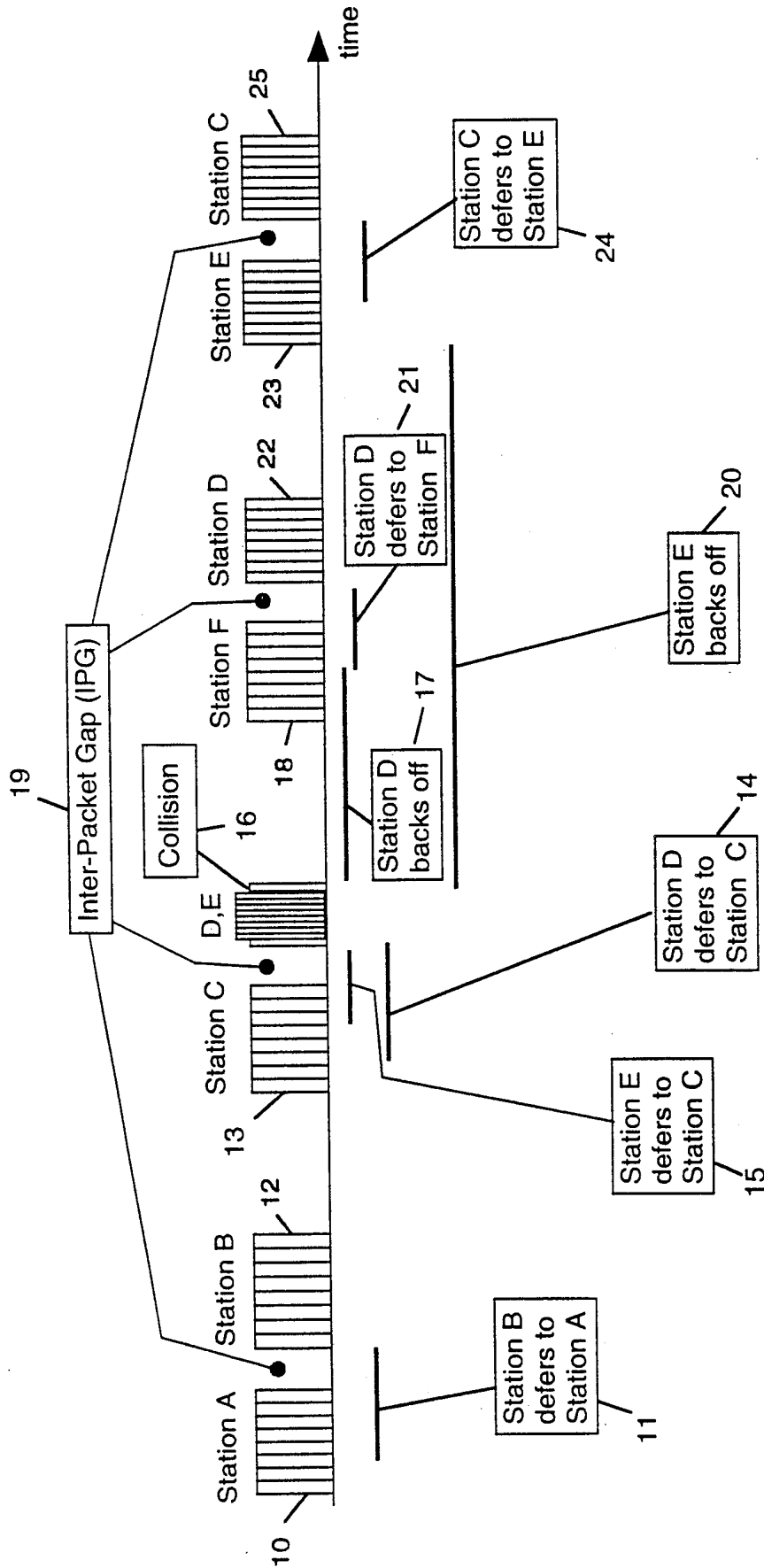

FIG. 1b

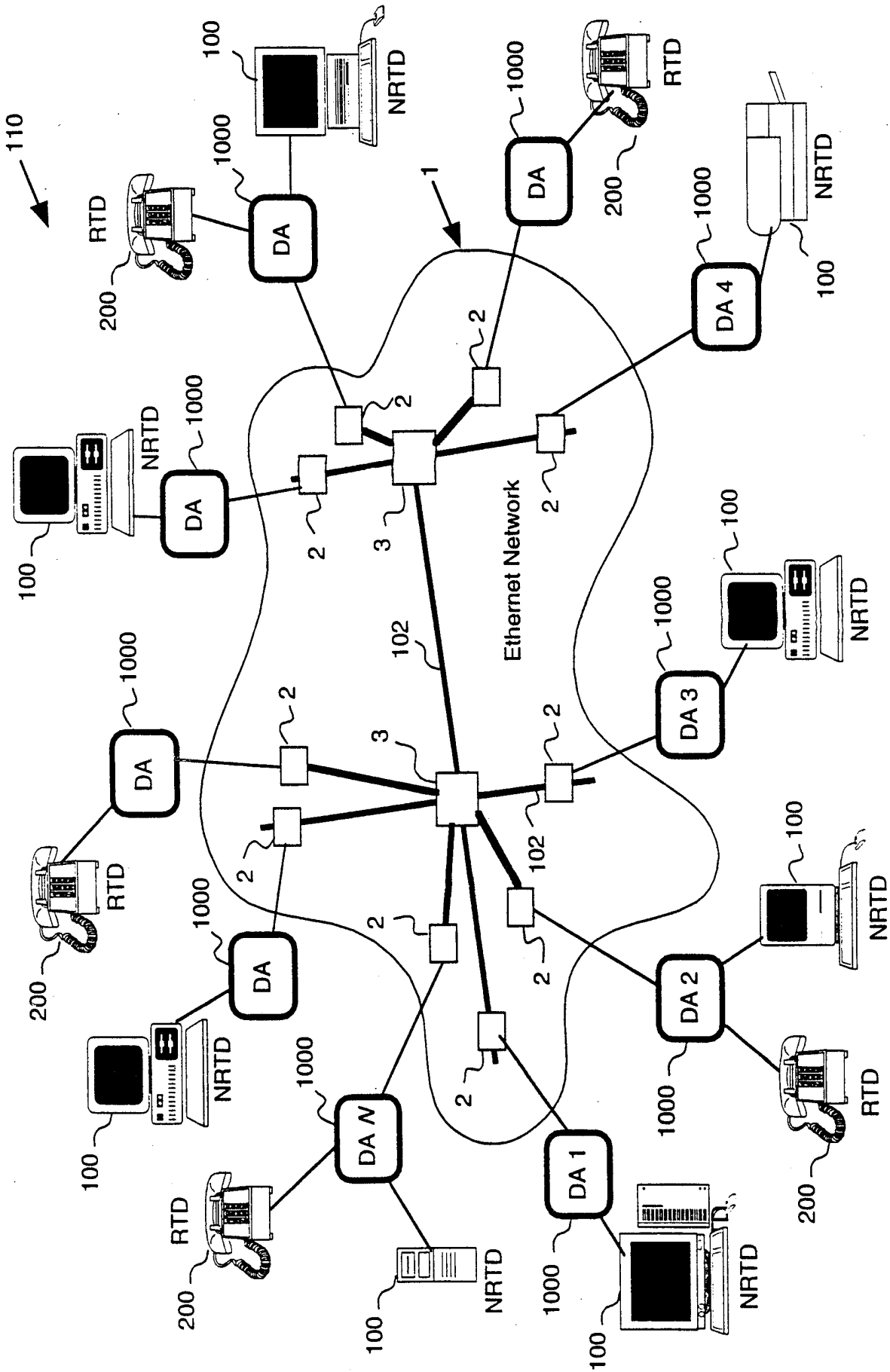

FIG. 2

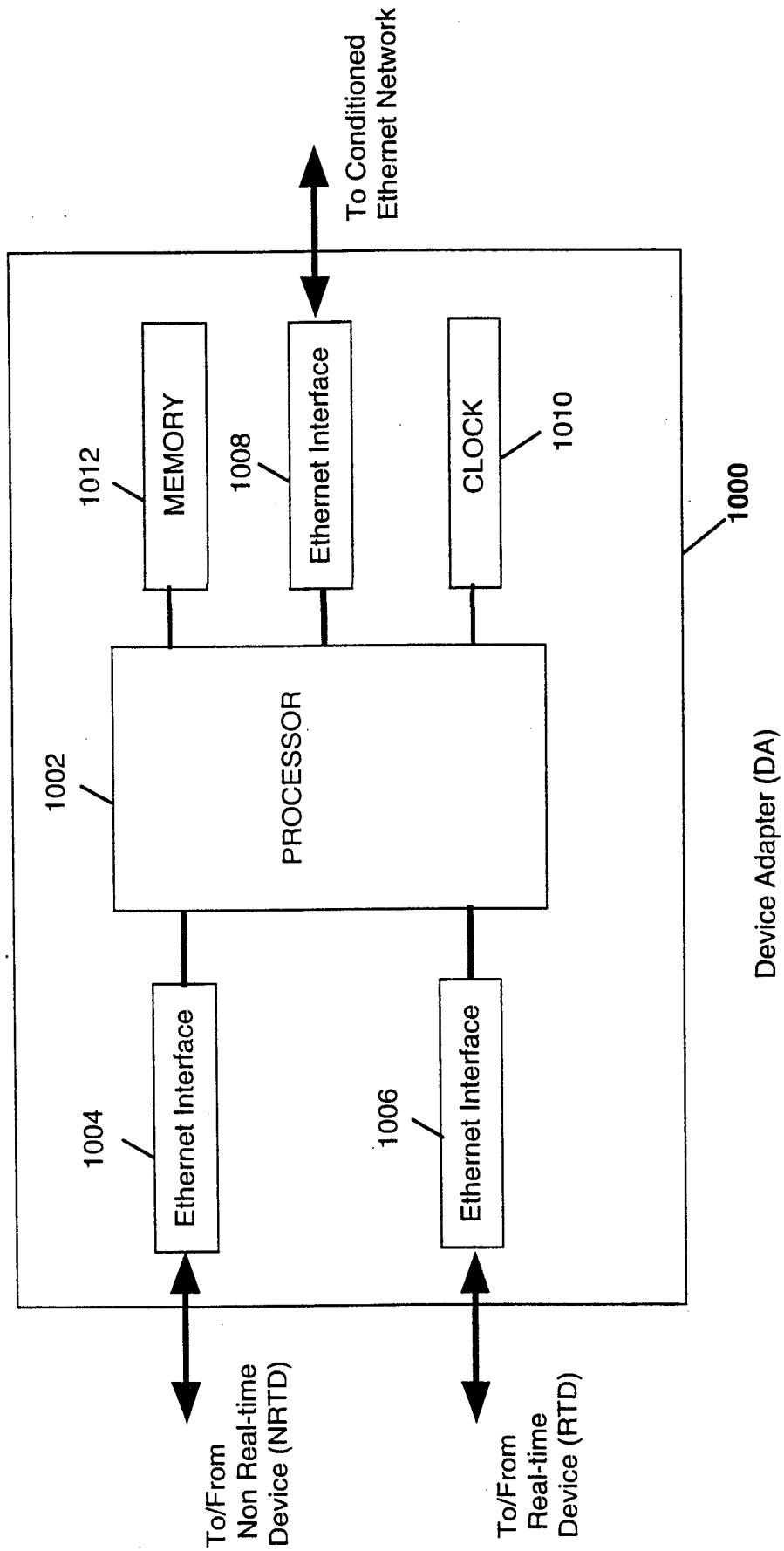

FIG. 3

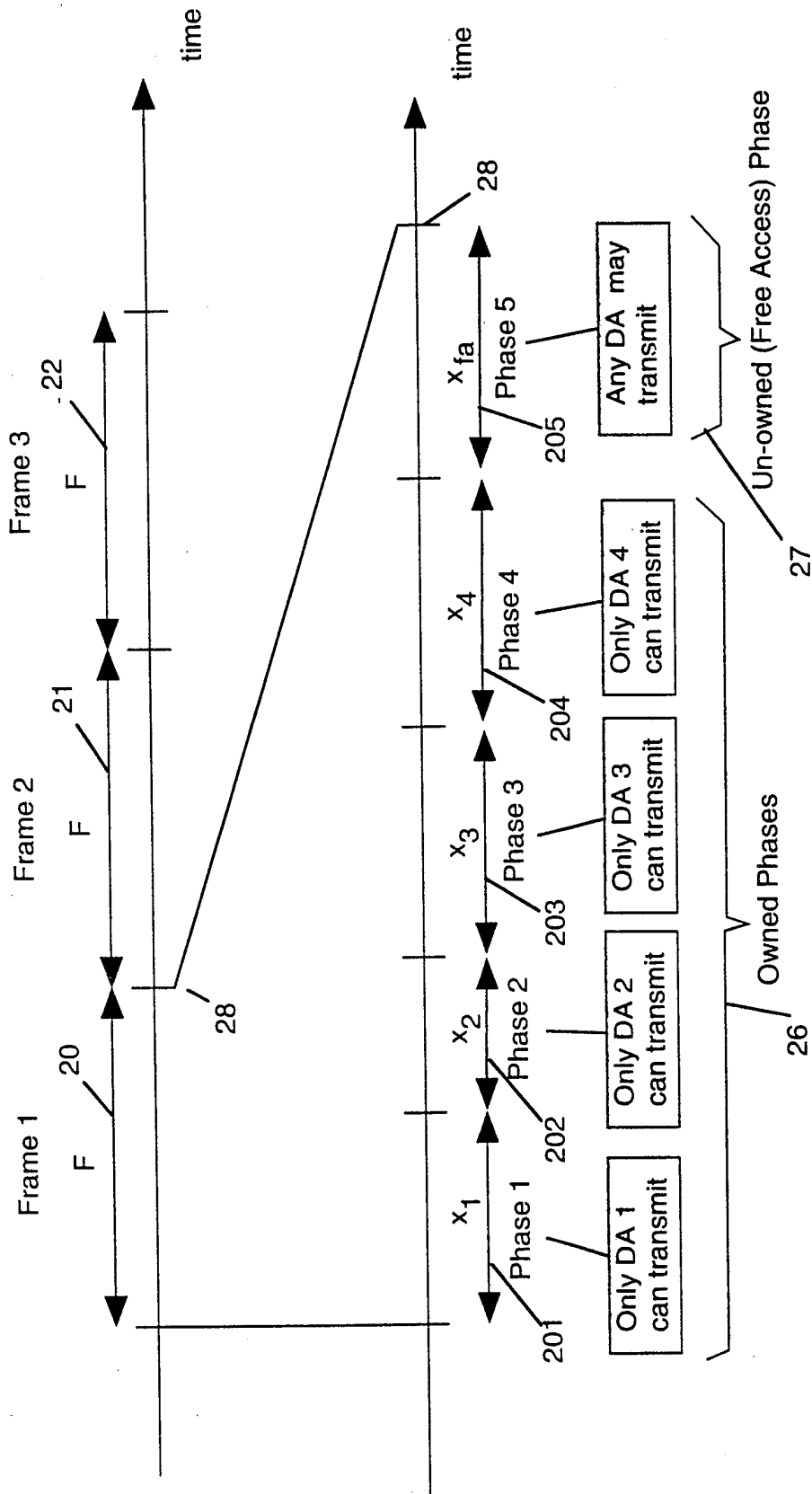

FIG. 4

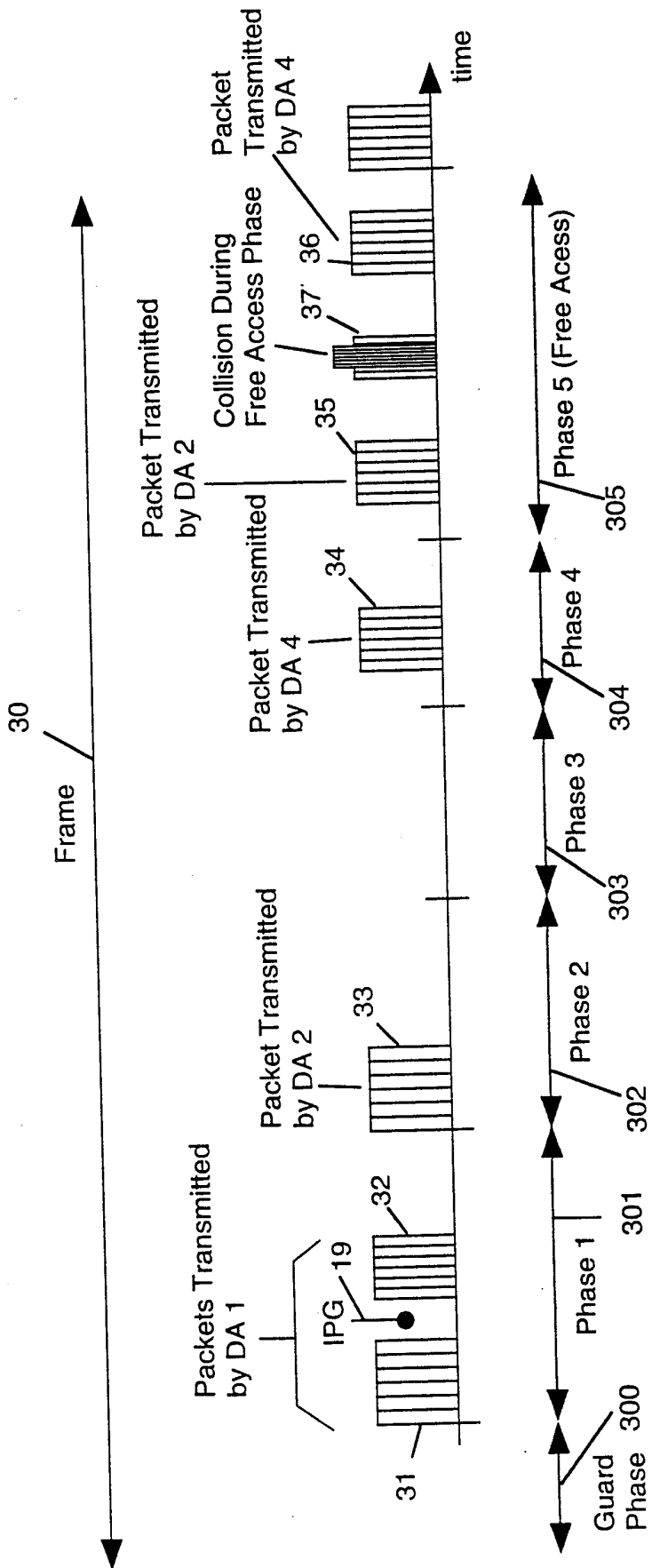

FIG. 5

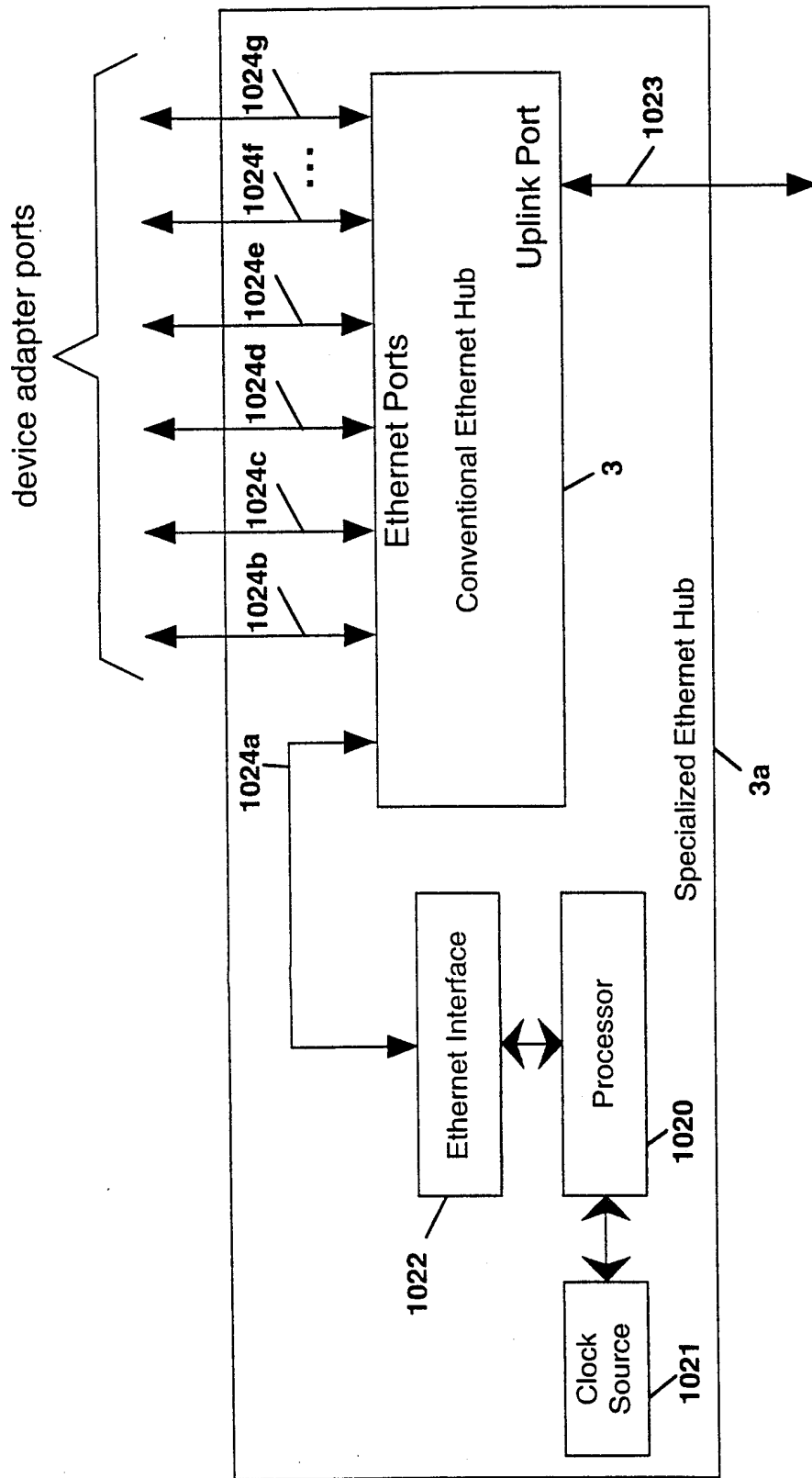

FIG. 6

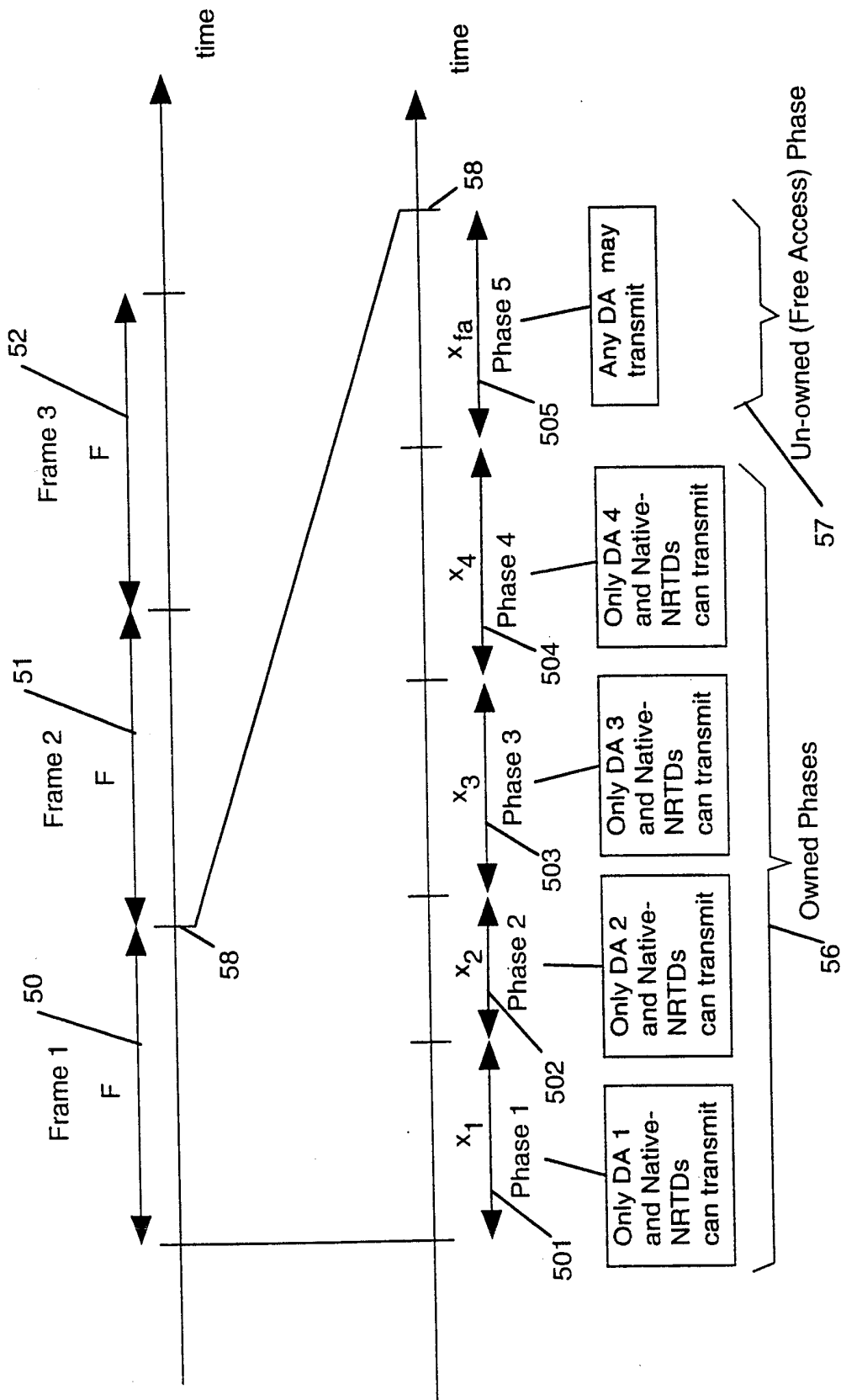

FIG. 8

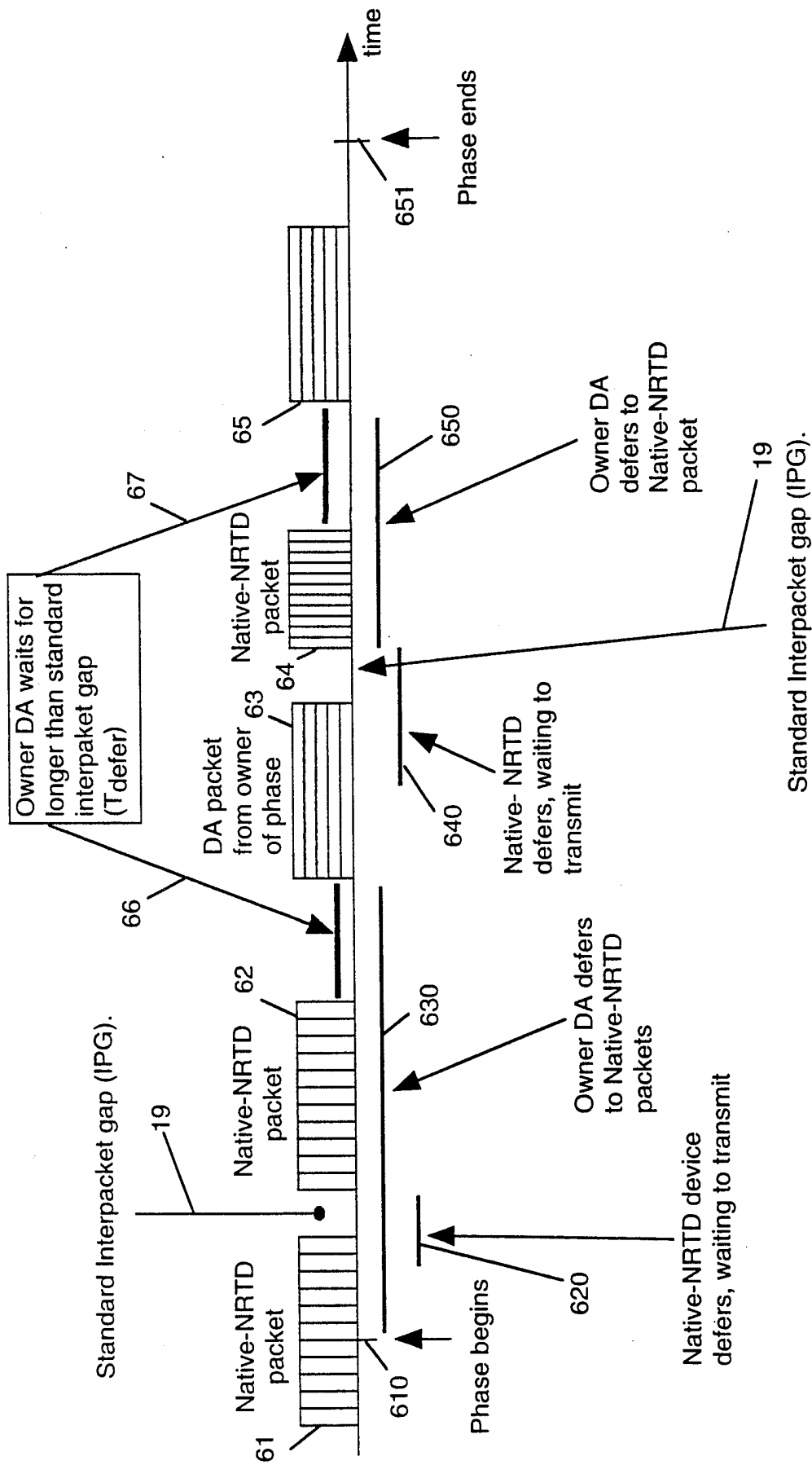

FIG. 9a

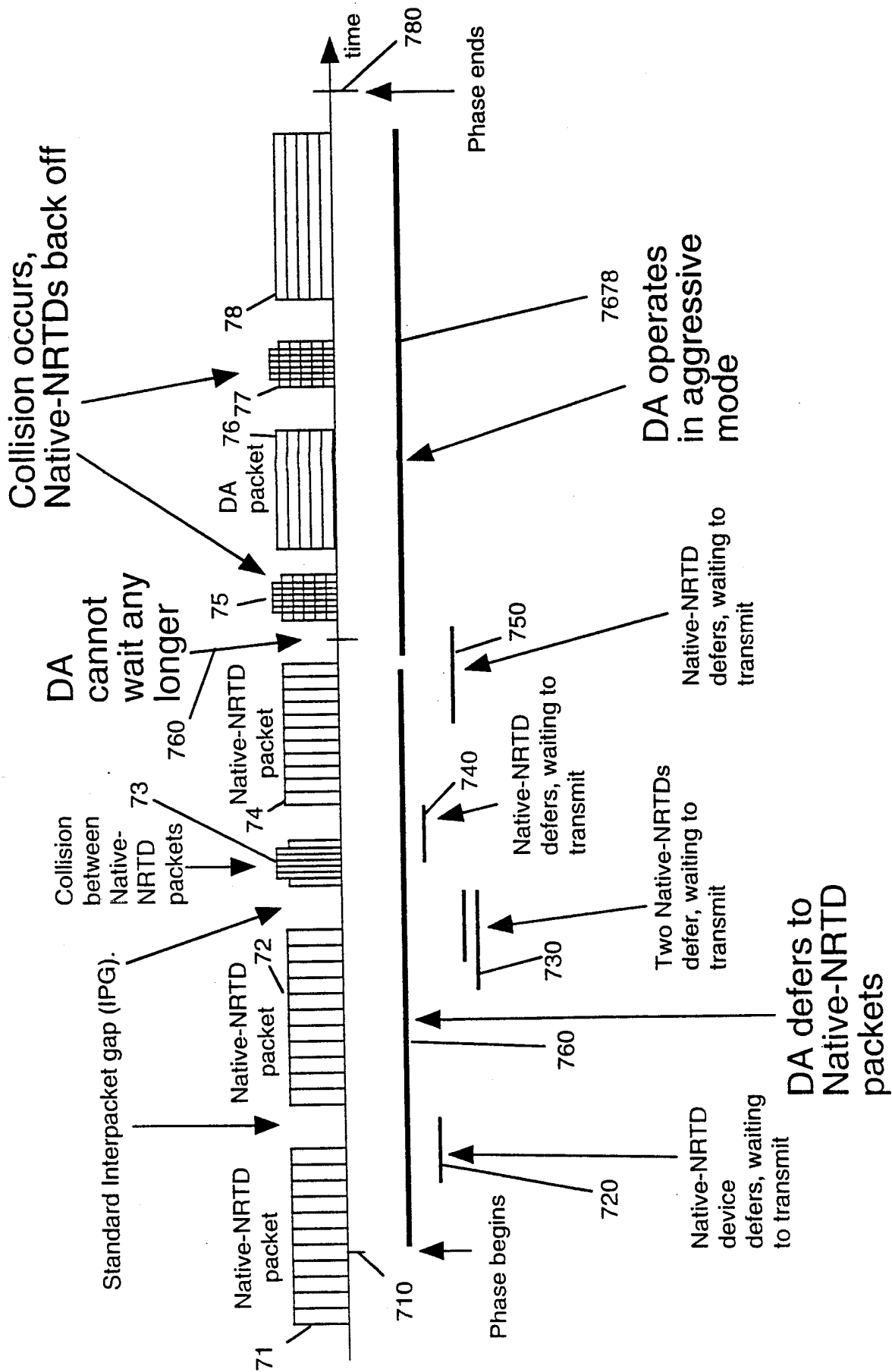
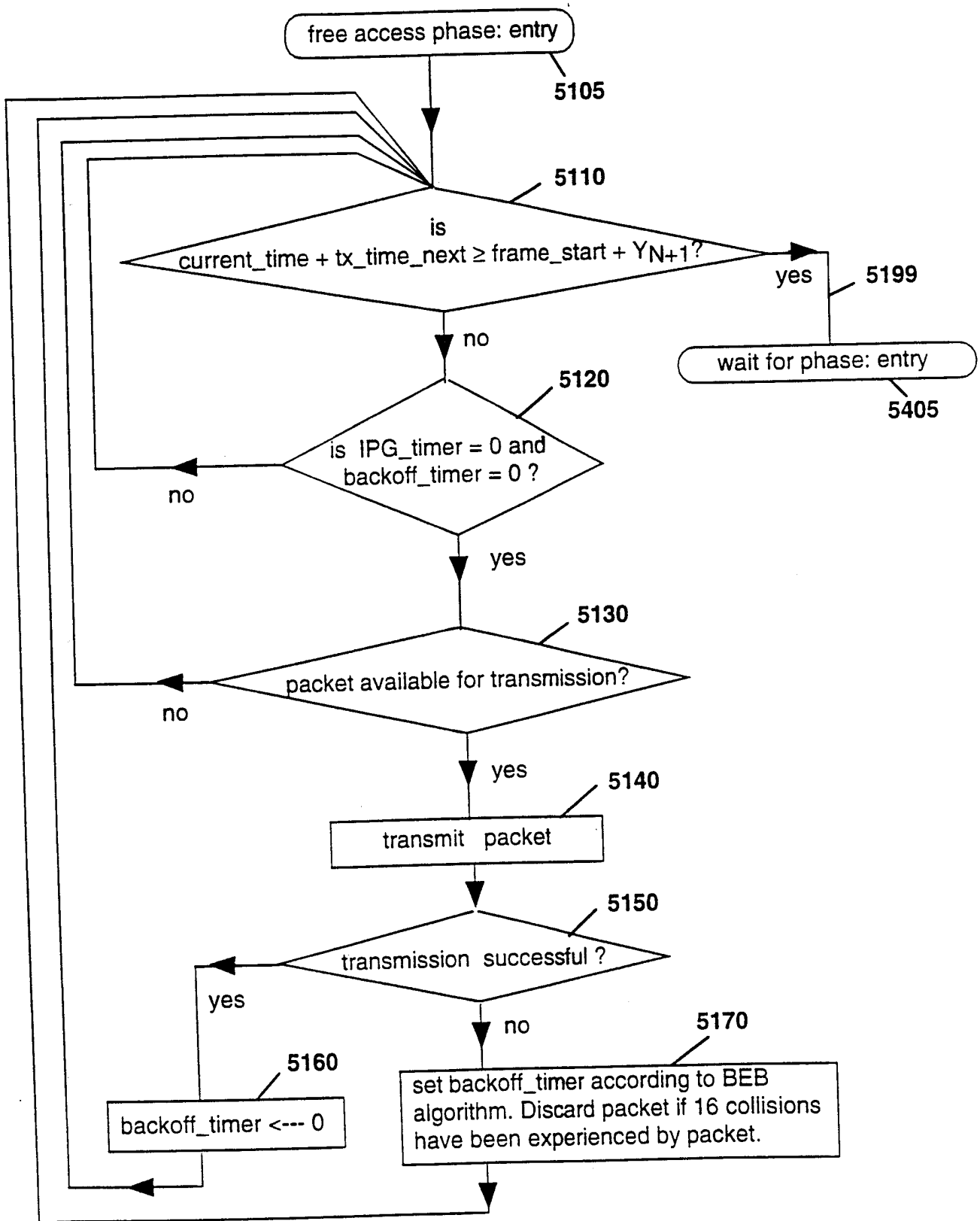
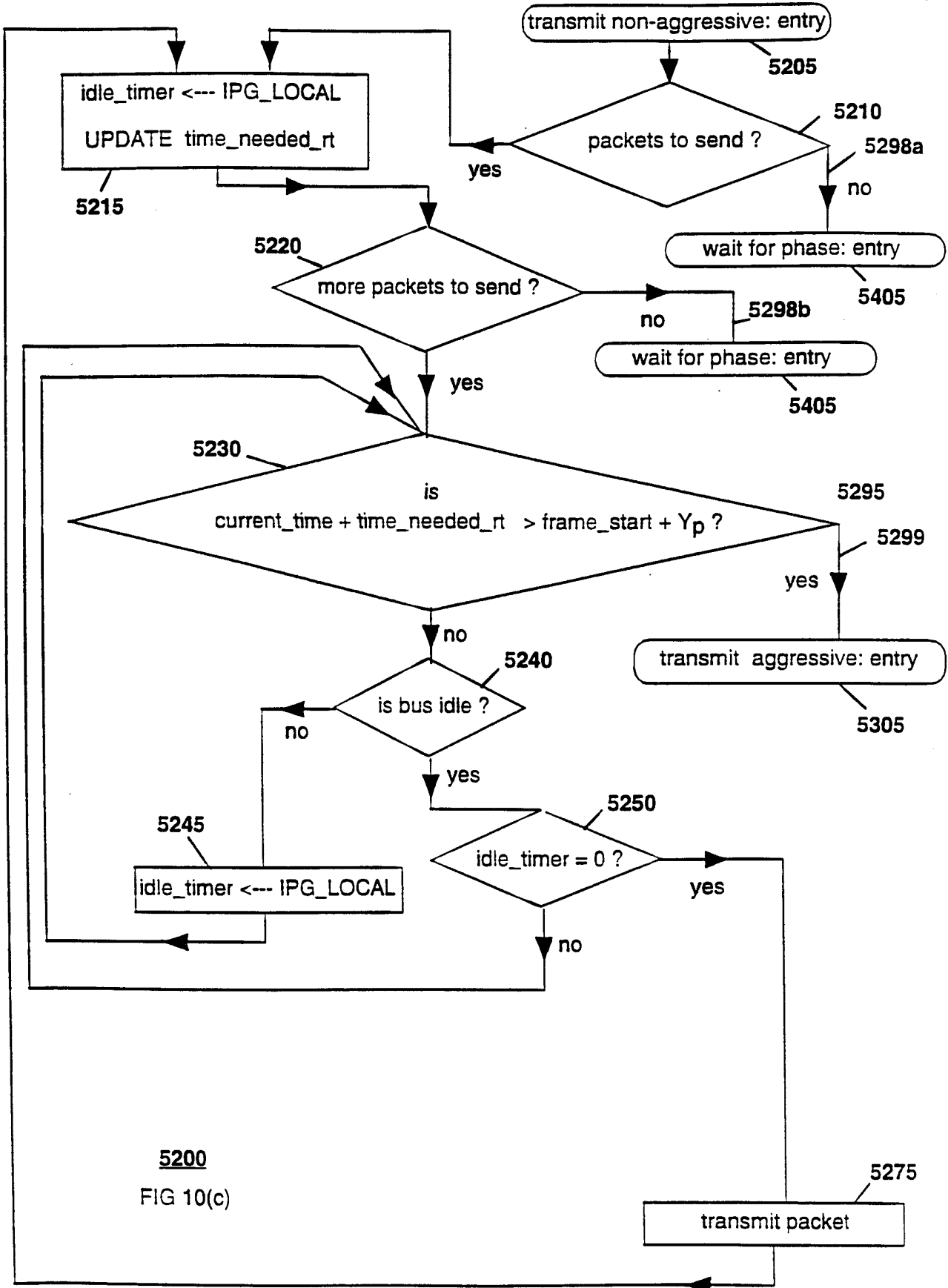

FIG. 9b



5100

FIG 10(b)



5200
FIG 10(c)

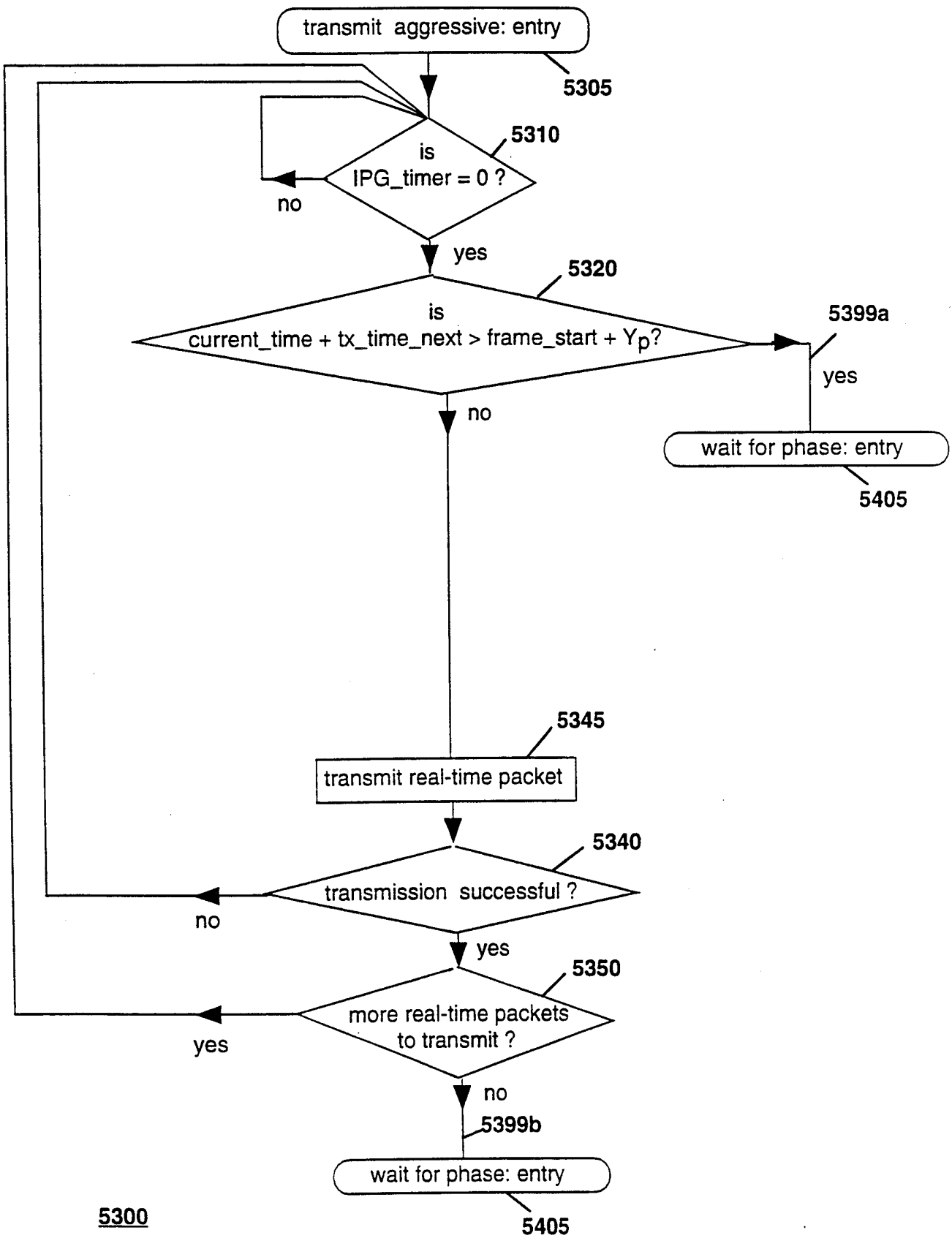

5300
FIG 10(d)

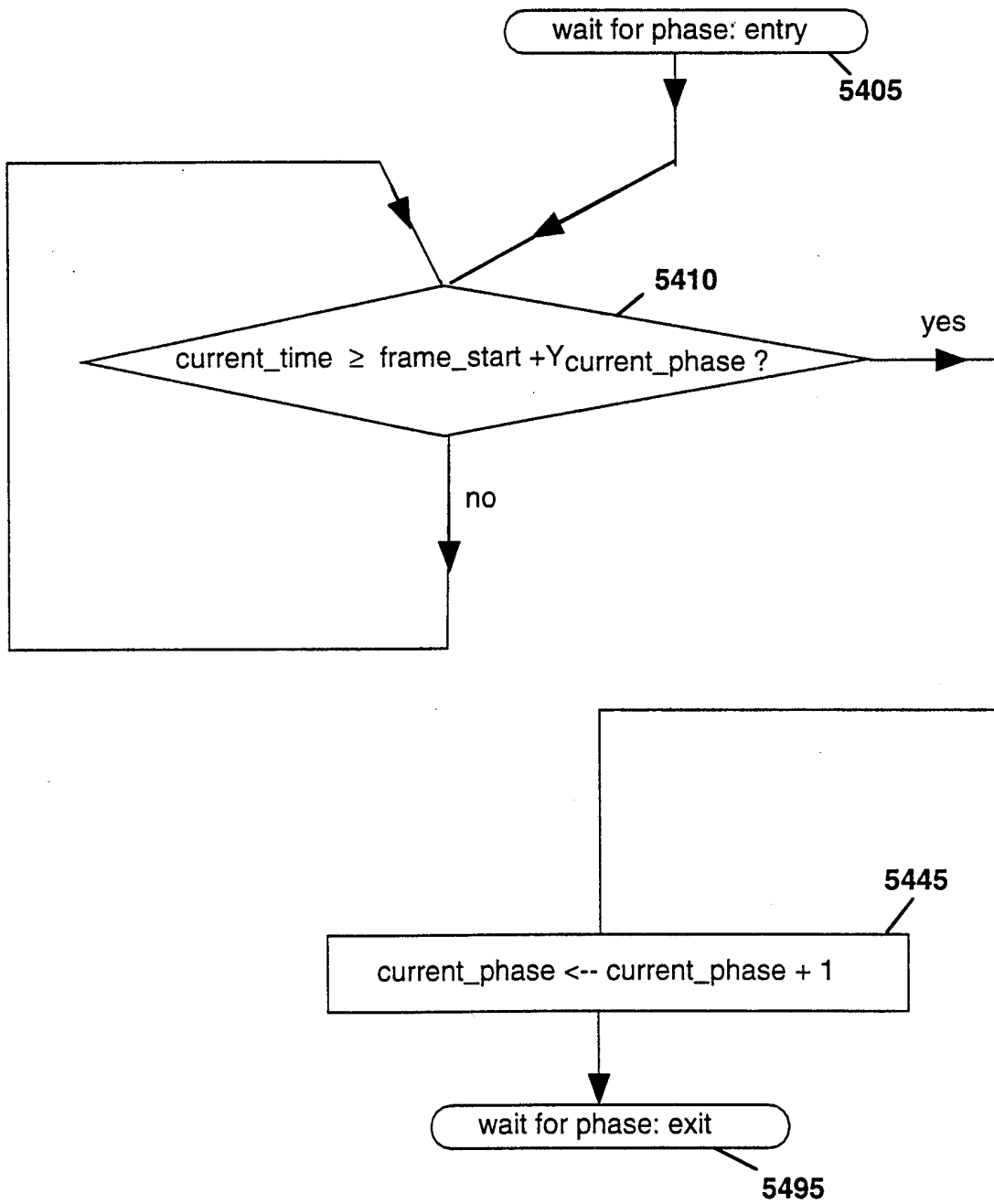

5400
FIG 10(e)

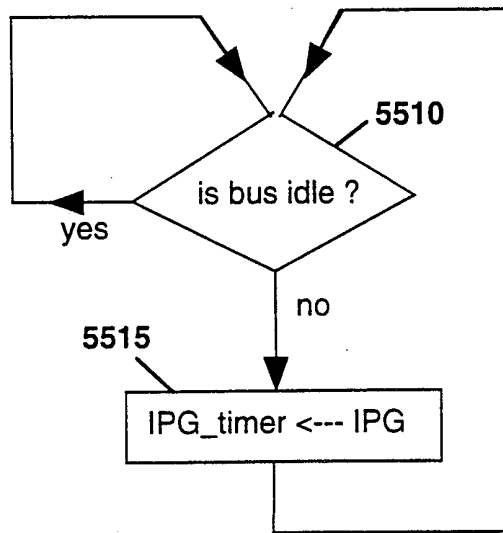

5500

FIG 10(f)

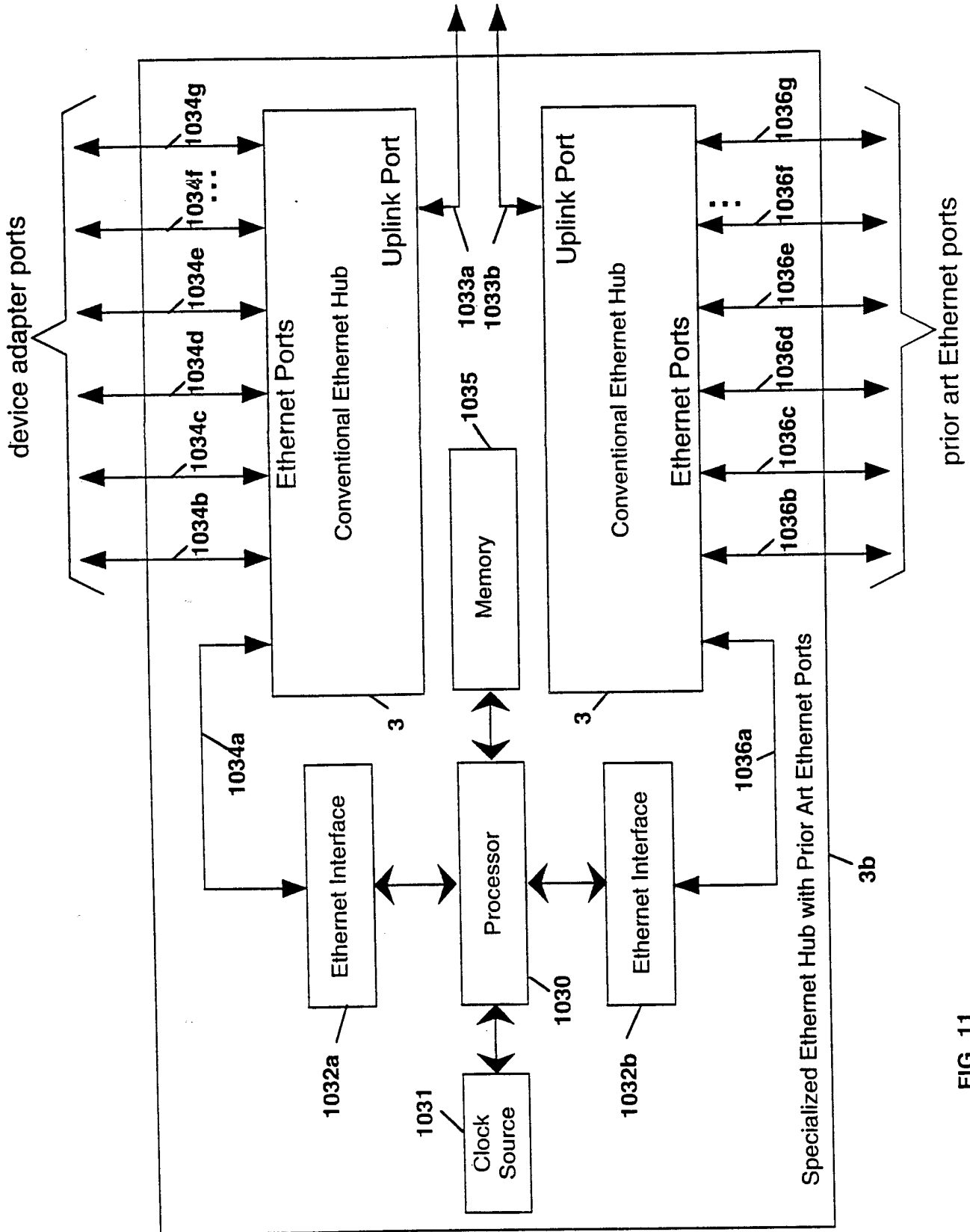

FIG. 11

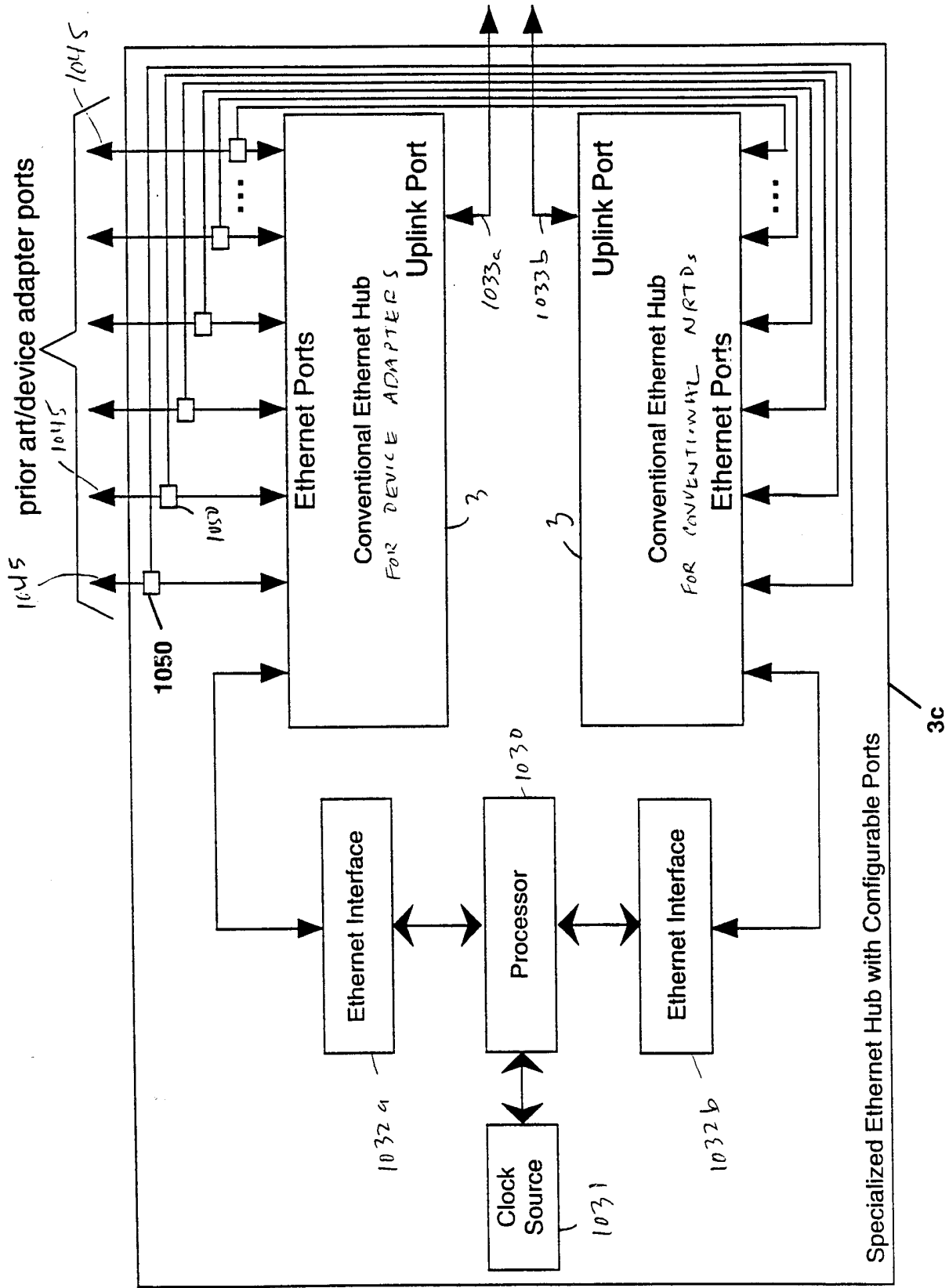

FIG. 12

INTERNATIONAL SEARCH REPORT

International application No.
PCT/US99/18984

A. CLASSIFICATION OF SUBJECT MATTER

IPC(6) :H04J 3/06
US CL :370/503

According to International Patent Classification (IPC) or to both national classification and IPC

B. FIELDS SEARCHED

Minimum documentation searched (classification system followed by classification symbols)

U.S. : Please See Extra Sheet.

Documentation searched other than minimum documentation to the extent that such documents are included in the fields searched

Electronic data base consulted during the international search (name of data base and, where practicable, search terms used)

C. DOCUMENTS CONSIDERED TO BE RELEVANT

Category*	Citation of document, with indication, where appropriate, of the relevant passages	Relevant to claim No.
Y	US 5,732,094 A (PETERSEN et al) 24 March 1998, see Figs. 1-5 and 7-8, col. 3, lines 54-67, col. 4, lines 1-2, 23-25, 52-57, col. 5, lines 16-43, col. 6, lines 9-19, col. 11, lines 25-46, col. 12, lines 44-67, col. 13, lines 1-67, and col. 14, lines 1-5.	1-38, 41-55, 57-59, 67-80, and 82.
Y,E	US 5,953,344 A (DAIL et al) 14 September 1999, see Figs. 1, 3-4, and 20, col. 7, lines 23-67, col. 8, lines 1-44, col. 14, lines 53-67, col. 15, lines 1-67, and col. 16, lines 1-45.	1-38 and 41-42.
Y, P	US 5,905,869 A (HORNING et al) 18 May 1999, see Figs. 1, 4-6, col. 3, lines 15-37, col. 4, lines 28-67, col. 5, lines 1-67, and col. 6, lines 1-55.	43-55, 59, 62-64, 66-80, and 82.

Further documents are listed in the continuation of Box C. See patent family annex.

<p>* Special categories of cited documents:</p> <p>*A* document defining the general state of the art which is not considered to be of particular relevance</p> <p>*E* earlier document published on or after the international filing date</p> <p>*L* document which may throw doubts on priority claim(s) or which is cited to establish the publication date of another citation or other special reason (as specified)</p> <p>*O* document referring to an oral disclosure, use, exhibition or other means</p> <p>*P* document published prior to the international filing date but later than the priority date claimed</p>	<p>*T* later document published after the international filing date or priority date and not in conflict with the application but cited to understand the principle or theory underlying the invention</p> <p>*X* document of particular relevance; the claimed invention cannot be considered novel or cannot be considered to involve an inventive step when the document is taken alone</p> <p>*Y* document of particular relevance; the claimed invention cannot be considered to involve an inventive step when the document is combined with one or more other such documents, such combination being obvious to a person skilled in the art</p> <p>* & * document member of the same patent family</p>
--	---

Date of the actual completion of the international search	Date of mailing of the international search report
03 DECEMBER 1999	23 DEC 1999

<p>Name and mailing address of the ISA/US Commissioner of Patents and Trademarks Box PCT Washington, D.C. 20231</p> <p>Facsimile No. (703) 305-3230</p>	<p>Authorized officer PHIRIN SAM <i>For Phirin Sam</i></p> <p>Telephone No. (703) 308-9294</p>
---	--

INTERNATIONAL SEARCH REPORT

International application No.
PCT/US99/18984

C (Continuation). DOCUMENTS CONSIDERED TO BE RELEVANT		
Category*	Citation of document, with indication, where appropriate, of the relevant passages	Relevant to claim No.
Y, P ----- X, P	US 5,878,232 A (MARIMUTHU) 02 March 1999, see Fig. 1, col. 3, lines 66-67, col. 4, lines 1-67, and col. 5, lines 1-22.	57-59, 62-64, and 66. ----- 60, 61, and 65.

INTERNATIONAL SEARCH REPORT

International application No.
PCT/US99/18984

B. FIELDS SEARCHED

Minimum documentation searched

Classification System: U.S.

370/503, 257, 258, 270, 294, 340, 341, 345, 346, 347, 348, 349, 350, 392, 395, 416, 420, 421, 422, 423, 424, 425, 426, 428, 437, 442, 443, 445, 450, 451, 453, 454, 457, 460, 461, 462, 463, 464, 465, 468, 470, 493