

1 가 (6) (2) (6) (2) (8) (6) (4) (6) 가 (4)가 (8) , 가 (10) , (12) (6) (4) 가 (1) (6) (2) 가 (8) (14) (16) (10) (18)가 (18) (10) (6) (20) (10)가 (6) / (8) (6) (24) , (24) (22) , (22) (8) (6) (10) (2) (6) (28) , (28) (6) (2) (8) (24) (30) , (28) (32) (6) (20) (24) (26) , (30) (32) (24) (26) , (30) (22) (12) 가 (A)(B) 가 (A)(B) (30) (8) (22) (24) (26)가 (32) (28) , (30)가 (A)(B) (8) (22) (6) (20) 가 (A)(B) (30)가 (12) 가 (A)(B) (12) 가 (A)(B) (10) (30) (12) (12) 가 (A)(B) (30) (28) , (12) (6) , (22) , 가 (A)(B) (12) (6) , (12)가

4 2 가 ,
 , 1 (20) / (10) (30) , (8) (22) 2 가 (6)
 (52) 2 가 (50) (56) (58) (50) (58)
 6) (50) 4 (54) (60) (50) (52) , (5
 (50) 5 (56) (60) , (54) (58) (54) ,
 50)가 가 () (54) , (50) , ()
 가 가 가 (52) 가 (58) (56)가 4 (50) , ()
 (62) 가 가 (56) (62)

가 , 가 , 가 ,

(57)

1. 가 가 , 가 가 가
2. 1 / 가 가 가
3. 1 가 /

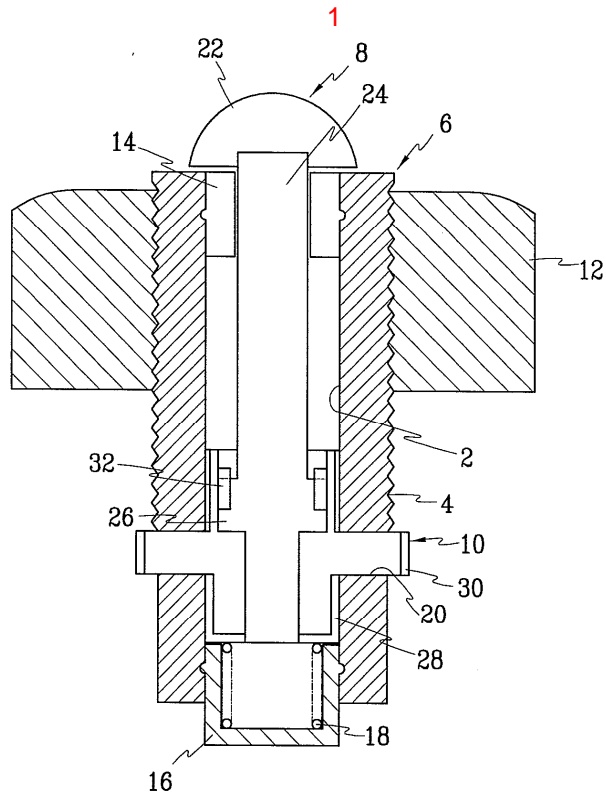

2a

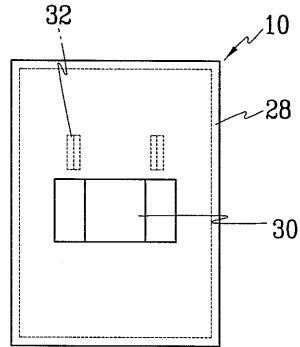

2b

