

AUSTRALIA

PATENTS ACT 1990

NOTICE OF ENTITLEMENT

We, **NSK RHP EUROPEAN TECHNOLOGY CO. LIMITED**, of Mere Way, Ruddington Fields Business Park, Ruddington, Nottingham NG11 6JZ, United Kingdom, being the applicant and nominated person in respect of Application No. 77024/94, state the following:-

1. The person nominated for the grant of the patent has entitlement from the actual inventor by mesne assignment.
2. The person nominated for the grant of the patent has entitlement from the applicant of the application listed in the declaration under Article 8 of the PCT by assignment.
3. The basic application listed in the declaration under Article 8 of the PCT is the first application made in a Convention country in respect of the invention.

For and on behalf of

**NSK RHP EUROPEAN TECHNOLOGY CO. LIMITED**



(Signature)

12th March, 1996

(Date)

Name: Peter R. Heathcote

Title: Patent Attorney

File: 18648



AU9477024

(12) PATENT ABRIDGMENT (11) Document No. AU-B-77024/94  
(19) AUSTRALIAN PATENT OFFICE (10) Acceptance No. 685847

- (54) Title  
LOCKING DEVICE FOR USE WITH SHAFTS OR TUBES
- International Patent Classification(s)  
(51)<sup>6</sup> F16C 035/063 F16D 001/08 F16C 035/067
- (21) Application No. : 77024/94 (22) Application Date : 26.09.94
- (87) PCT Publication Number : WO95/09310
- (30) Priority Data
- (31) Number (32) Date (33) Country  
9319880 27.09.93 GB UNITED KINGDOM
- (43) Publication Date : 18.04.95
- (44) Publication Date of Accepted Application : 29.01.98
- (71) Applicant(s)  
NSK RHP EUROPEAN TECHNOLOGY CO. LIMITED
- (72) Inventor(s)  
GEORGE SWINLEY
- (74) Attorney or Agent  
SHELSTON WATERS , Level 21, 60 Margaret Street, SYDNEY NSW 2000
- (56) Prior Art Documents  
EP 88589  
DE 3822472
- (57) Claim

1. A device for locking to a component rotatable about an axis, said device comprising collar means having an end wall with a bore defining a surface for confronting an outer surface of the component and a region extending axially from the end wall, a ring for disposing between the axial region of the collar means and the component, the ring having a first inner surface for confronting the outer surface of the component and a second outer surface which is inclined relative to the axis of rotation to converge with respect to the axis of rotation in a direction away from the end wall and several screw-threaded elements received in threaded bores extending radially through the axial region of the collar means and spaced apart relative to the rotational axis other than at 180°, the arrangement being such that the screw-threaded elements can be

(11) AU-B-77024/94  
(10) 685847

-2-

tightened to bear into or against the second outer surface of the ring to cause the bore surface of the collar means and the first surface of the ring to act as contact surfaces with respect to the outer surface of the component which exert clamping force on the component at diametrically opposed zones.



(51) International Patent Classification 6 : F16C 35/063, 35/067, F16D 1/08	A1	(11) International Publication Number: <b>WO 95/09310</b> (43) International Publication Date: 6 April 1995 (06.04.95)
--	----	---

(21) International Application Number: PCT/GB94/02090  
 (22) International Filing Date: 26 September 1994 (26.09.94)  
 (30) Priority Data:  
 9319880.2 27 September 1993 (27.09.93) GB

(81) Designated States: AM, AT, AU, BB, BG, BR, BY, CA, CH, CN, CZ, DE, DK, ES, FI, GB, GE, HU, JP, KE, KG, KP, KR, KZ, LK, LT, LU, LV, MD, MG, MN, MW, NL, NO, NZ, PL, PT, RO, RU, SD, SE, SI, SK, TJ, TT, UA, US, UZ, VN, European patent (AT, BE, CH, DE, DK, ES, FR, GB, GR, IE, IT, LU, MC, NL, PT, SE), OAPI patent (BF, BJ, CF, CG, CI, CM, GA, GN, ML, MR, NE, SN, TD, TG), ARIPO patent (KE, MW, SD, SZ).

~~(71) Applicant (for all designated States except US): RHP BEARINGS LIMITED (GB/GB), Northern Road, P.O. Box 18, Newark, Nottingham NG24 2JF (GB);~~

Published  
 With international search report.

see folio 5

(72) Inventor; and  
 (75) Inventor/Applicant (for US only): SWINLEY, George [GB/GB]; 18 Acacia Drive, Townville, Castleford, West Yorks WF10 4PT (GB).

685847

(74) Agent: BARNARD, Eric, E.; Brookes & Martin, High Holborn House, 52/54 High Holborn, London WC1V 6SE (GB).



(71) NSK RHP EUROPEAN TECHNOLOGY CO. LIMITED  
 Mere Way  
 Ruddington Fields Business Park  
 Ruddington, Nottingham NG11 6JZ United Kingdom;

(54) Title: LOCKING DEVICE FOR USE WITH SHAFTS OR TUBES

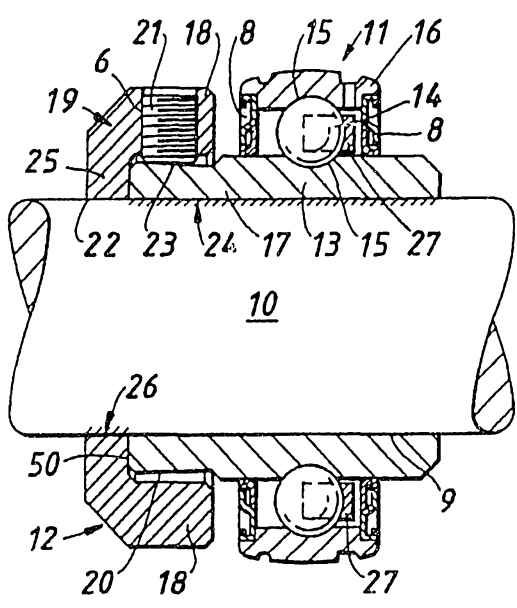

(57) Abstract

A locking device for clamping onto a shaft (10) is composed of a collar (19) and a ring (13, 17) fitted onto the shaft (10). The collar (19) has an end wall (25) and an axial region (18) extending over an outer inclined contact surface (20) of the ring (13, 17). The ring (13, 17) and the collar end wall (25) have inner contact surfaces (9, 22) confronting the outer surface of the shaft (10) which are separated by sliding radial surfaces (50) of the collar (19) and the ring (13, 17). Screw-threaded elements (21) set in threaded bores (6) in the axial region (18) of the collar (19) can be tightened against the outer contact surface (20) of the ring (13, 17) to cause the inner contact surfaces (9, 22) to exert clamping force on the shaft (10).

LOCKING DEVICE FOR USE WITH SHAFTS OR TUBES

TECHNICAL FIELD

The present invention relates to a device which can be selectively locked or clamped to a shaft or tube.

5 BACKGROUND TO THE INVENTION

In many mechanical applications it is necessary to clamp one component, such as a bearing, a sprocket or a pulley, to a rotatable component, such as a shaft or spindle.

One simple way of clamping the component in place is to use one or more grub or set screws which engage with the outer surface of the shaft. The set screws can then be  
10 received in screw threaded or tapped bores in the component. In the case of a bearing the screws are placed in tapped bores in the inner ring. The screws tend to damage the shaft particularly if the component is removed from the shaft from time to time. The tightening of the screws also cause high tensile stresses in the inner ring and fracture can occur. The provision of the tapped bores also entails additional operations. Another  
15 well known design utilizes an eccentric collar with a set screw which when engaged also tends to damage the shaft. Moreover it is not easy to establish the direction of tightening or loosening when releasing the collar and the collar is prone to damage. The eccentric collar also requires specific machining.

It is an object of the present invention to overcome or substantially ameliorate at  
20 least some of the disadvantages of the prior art.

According to one aspect of the invention there is provided a device for locking to a component rotatable about an axis; said device comprising collar means having an end wall with a bore defining a surface for confronting an outer surface of the component



and a region extending axially from the end wall, a ring for disposing between the axial region of the collar means and the component, the ring having a first inner surface for confronting the outer surface of the component and a second outer surface which is inclined relative to the axis of rotation to converge with respect to the axis of rotation in a direction away from the end wall and several screw-threaded elements received in threaded bores extending radially through the axial region of the collar means and spaced apart relative to the rotational axis other than at 180°, the arrangement being such that the screw-threaded elements can be tightened to bear into or against the second outer surface of the ring to cause the bore surface of the collar means and the first surface of the ring to act as contact surfaces with respect to the outer surface of the component which exert clamping force on the component at diametrically opposed zones.

According to another aspect of the invention there is provided a device for locking to a hollow component rotatable about an axis; said device comprising collar means

5  
10



having an end wall with an outer surface for confronting an inner surface of the component and a region extending axially from the end wall; a ring for disposing between the axial region of the collar means and the component, the ring having a first outer surface for confronting the inner surface of the component and a second inner surface which is inclined relative to the axis of rotation to diverge with respect to the axis of rotation in a direction away from the end wall and several screw threaded elements received in threaded bores extending radially through the axial region of the collar means and spaced apart relative to the rotational axis other than at  $180^\circ$  the arrangement being such that the screw-threaded elements can be tightened to bear into or against the second inner surface of the ring to cause the outer surface of the ring and the outer surface of the end wall of the collar means to act as contact surfaces with respect to the inner surface of the component which exert clamping force on the component at diametrically opposed zones.

As will become apparent in the following description, the rotatable component may be a shaft or spindle with the locking device fitted onto its exterior periphery or a hollow shaft or tube with the locking device fitted inside.

It is not essential for the rotatable component to have a circular cross-section and the component can have a polygonal cross-section.



The ends of the screw-threaded elements may have plane surfaces parallel to the rotational axis or set at an angle which may have the same sense as the angle of the second surface of the ring. It is possible to provide shallow depressions, recesses or blind bores in the second surface for receiving the ends of the screw-threaded elements.

5 Preferably the confronting surfaces of the collar means and the ring which contact the component and exert clamping force therein lie directly alongside one another along the axis of rotation. Between these contact surfaces there may be radial guide surfaces of the ring and the collar means which engage on one another and slide against one another as the screw elements are tightened or released.

10 The invention may be understood more readily and various other aspects and features of the invention may become apparent, from consideration of the following description and accompanying drawings.

Embodiments of the invention will now be described by way of example only, with reference to the accompanying drawings therein:

15 Figure 1 is a part sectional representation of an assembly employing a locking device constructed in accordance with the invention and

Figure 2 is an schematic representation of another assembly and locking device constructed in accordance with the invention.



As shown in Figure 1, for a shaft 10 there is fitted a rolling-element bearing 11 and a locking device 12. The bearing 11 is composed of an extended inner ring 13 which is to be secured to the shaft 10 in a non-rotatable manner. The ring 13 has an inner confronting surface 9 extending parallel to the outer peripheral surface of the shaft 10. A set of rolling elements here in the form of balls 14, is disposed in raceways 15 between the inner ring 13 and an outer ring 16. The balls 14 are spaced apart round the raceways 15 with a cage 27 and seals 8 are mounted between the rings 13,16.

An axial end region 17 of the inner ring 13 is surrounded by an axial portion 18 of a collar 19. The collar 19 has an end wall 25 with a bore forming a confronting surface 22 fitted over the shaft 10 with the surface 22 forming a continuation of the inner surface 9 of the ring 13.

The outer surface of the region 17 of the bearing inner ring 13 is relieved to provide an outer surface 20 which is tapered to extend at an angle to the axis of the shaft 10. The surface 20 converges towards the shaft axis in the direction of the bearing 11. A typical angle for the surface 20 is 3° and generally an angle in the range 1° to 5° is preferred.

Two screws 21 are located in threaded bores 6 in the axial portion 18 of the collar 19 disposed 120° apart around the axis of the shaft 10. This angle is not critical and may vary depending on the application. The screws 21 can be displaced inwardly of the bores



6 to engage on the outer surface 20 of the ring 13. In a modified arrangement the surface has shallow recesses or depressions or blind bores for locating and receiving the ends 23 of the screws 21. The inner ring 13 of the bearing 11 and the collar 19 can be easily fitted onto the shaft 10 and the screws 21 are then tightened to some  
5 predetermined torque. The ends 23 of the screws 21, which can be tapered at the same angle as the contact surface 20, press on the outer surface 20 to displace the axial end region 17 of the inner ring 13 and the axial portion 18 of the collar 19 radially part. This in turn causes diametrically opposed surface contact zones 24, 26 of the inner surface 9 of the ring 13 and of the bore surface 22 in the end wall 25 of the collar 19 to clamp  
10 against the shaft 10 uniformly without causing damage to the shaft 10. To release the locking device 12 the screws 21 are untightened to permit the collar 19 and the bearing 11 to be withdrawn from the shaft 10.

The end wall 25 of the collar 19 and the end of the axial region 17 of the ring 13 abut to form sliding guide surfaces 50 as the screws 21 are tightened or released.

15 Figure 2 depicts another locking device 12 which is fitted inside a hollow shaft or tube 120. The locking device is again composed of a collar 190 with an axial region 180 with two angularly offset threaded bores 220 receiving screws 210. An end wall 250 of the collar has an outer peripheral surface 280 which is parallel to and confronts an inner surface 300 of the tube 120. A ring 170 has an outer peripheral surface 240 which is  
20 parallel to and likewise confronts the inner surface 300 of the tube 120 and an inner



surface 200 which is tapered at an angle to the axis of the tube 120. As with the figure 1 embodiment, the surface 200 can be inclined at an angle of 1 to 5° and preferably 3° to the axis of the tube 120 and/or the surface 200 can contain shallow recesses, depressions or blind bores for receiving the ends 230 of the screws 210.

5           The device 12 is locked to the tube 120 by tightening the screws 210 to cause their ends 230 to displace the axial region 180 of the collar 190 and the ring 170 radially apart. This in turn causes diametrically opposed surface contact zones 290, 291 of the surface 280 of the collar end wall 250 and of the surface 240 of the ring 170 to bearing against the inner surface 300 of the tube 120 to lock the device in place.

10           The ring 170 and the end wall of the collar 190 have radial faces which abut and establish slidable guide surfaces 350 as the screws 210 are tightened or released. The device can be used to provide an abutment or location for some other components such has a bearing.

15           In contrast to some known forms of locking device or mechanisms, a device in accordance with the invention does not damage the rotatable component and is easily fitted and removed repeatedly. In the Figure 1 arrangement the inner ring 13 is simply extended and easily machined in one operation. There is no need to provide tapped bores in the ring 13. Also since no excessive tensile stresses are created on the inner ring



13 there is no danger of fracture for this reason. There is also no distortion so the raceways for the balls are unaffected.

13  
13  
13



THE CLAIMS DEFINING THE INVENTION ARE AS FOLLOWS:

1. A device for locking to a component rotatable about an axis; said device comprising collar means having an end wall with a bore defining a surface for confronting an outer surface of the component and a region extending axially from the end wall, a ring for disposing between the axial region of the collar means and the component, the ring having a first inner surface for confronting the outer surface of the component and a second outer surface which is inclined relative to the axis of rotation to converge with respect to the axis of rotation in a direction away from the end wall and several screw-threaded elements received in threaded bores extending radially through the axial region of the collar means and spaced apart relative to the rotational axis other than at  $180^\circ$ , the arrangement being such that the screw-threaded elements can be tightened to bear into or against the second outer surface of the ring to cause the bore surface of the collar means and the first surface of the ring to act as contact surfaces with respect to the outer surface of the component which exert clamping force on the component at diametrically opposed zones.

2. A device for locking to a hollow component rotatable about an axis; said device comprising collar means having an end wall with an outer surface for confronting an inner surface of the component and a region extending axially from the end wall; a ring for disposing between the axial region of the collar means and the component, the ring having a first outer surface for confronting the inner surface of the component and a second inner surface which is inclined relative to the axis of rotation to diverge with



respect to the axis of rotation in a direction away from the end wall and several screw threaded elements received in threaded bores extending radially through the axial region of the collar means and spaced apart relative to the rotational axis other than at 180° the arrangement being such that the screw-threaded elements can be tightened to bear into  
5 or against the second inner surface of the ring to cause the outer surface of the ring and the outer surface of the end wall of the collar means to act as contact surfaces with respect to the inner surface of the component which exert clamping force on the component at diametrically opposed zones.

3. A device according to claim 1 or 2, wherein the confronting surface of the collar  
10 means and the first surface of the ring lie closely adjacent to form a continuation of one another.

4. A device according to claim 3, wherein between the second confronting surface of the collar means and the first surface of the ring there are radially abutting guide surfaces of the collar means and of the ring which slide against one another as the screw-threaded  
15 elements are tightened or released.

5. A device according to any one of claims 1 to 4, wherein the screw-threaded elements have end surfaces for contacting the second surface of the ring which are inclined relative to the axis of rotation.

6. A device according to any one of claims 1 to 5, wherein there are two screw-  
20 threaded elements.

7. A device according to claim 6, wherein the threaded bores for receiving the screw-  
threaded elements are spaced apart by 120° relative to the axis of rotation.



8. A device according to any one of claims 1 to 7, wherein the second surface of the ring has depressions, recesses or blind bores for receiving the ends of the screw-threaded elements.

5 9. A device according to claim 1 or according to any one of claims 3 to 8, when appended to claim 1, wherein the rotatable component is a solid shaft or spindle.

10. A device according to claim 9, wherein the ring is itself another component of, or part of, some other structure which is to be locked with the device.

11. A device according to claim 10, wherein the ring is formed by an extended region of the inner ring of a rolling element bearing.

10 12. A device according to claim 2 or any one of claims 3 to 8 when appended to claim 2, wherein the component is a hollow shaft or tube.

13. A device according to any one of the preceding claims, wherein the second surface of the ring is inclined at an angle of  $1^{\circ}$  to  $5^{\circ}$  to the axis of rotation.

15 14. An assembly composed of a device according to any one of the preceding claims in combination with the rotatable component.

15. A device or assembly substantially as described with reference to and as illustrated in Figure 1 or Figure 2 of the accompanying drawing.

DATED this 4th Day of October, 1997  
NSK RHP European Technology Co. Limited

Attorney: CAROLINE M. BOMMER  
Fellow Institute of Patent Attorneys of Australia  
of SHELSTON WATERS



77024/94

1/1  
FIG. 1.

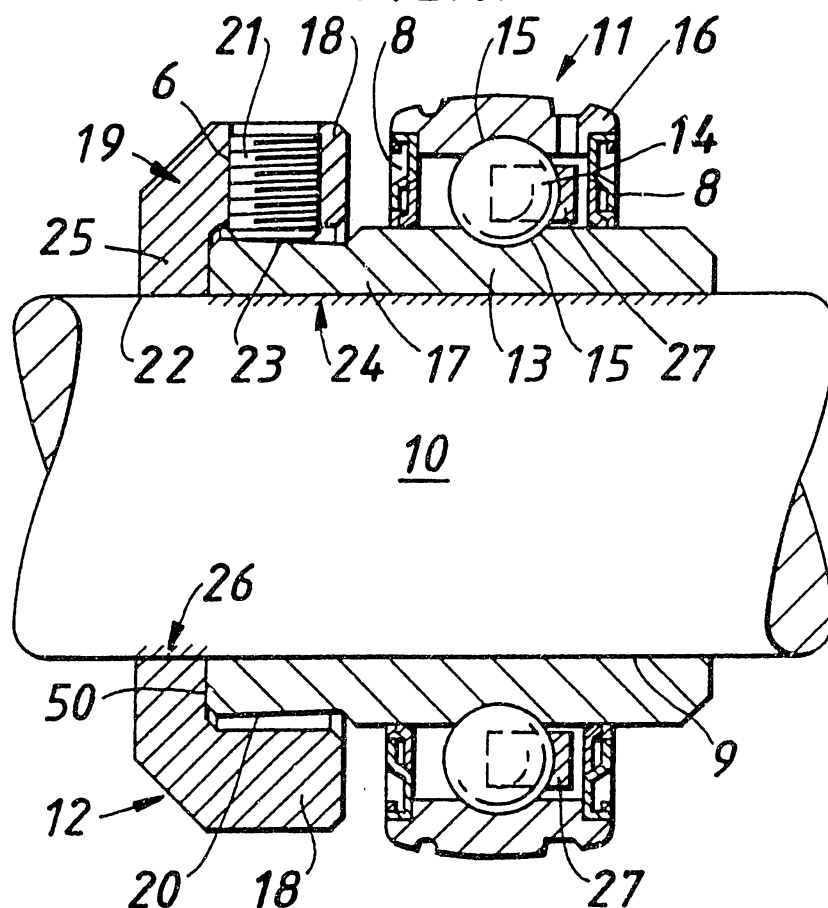
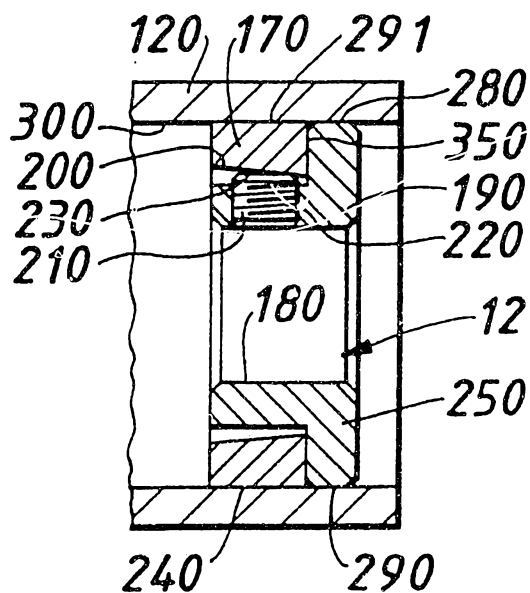

FIG. 2.



# INTERNATIONAL SEARCH REPORT

International Application No  
PCT/GB 94/02090

<b>A. CLASSIFICATION OF SUBJECT MATTER</b> IPC 6 F16C35/063 F16C35/067 F16C1/08		
According to International Patent Classification (IPC) or to both national classification and IPC		
<b>B. FIELDS SEARCHED</b>		
Minimum documentation searched (classification system followed by classification symbols) IPC 6 F16C F16D F16B		
Documentation searched other than minimum documentation to the extent that such documents are included in the fields searched		
Electronic data base consulted during the international search (name of data base and, where practical, search terms used)		
<b>C. DOCUMENTS CONSIDERED TO BE RELEVANT</b>		
Category *	Citation of document, with indication, where appropriate, of the relevant passages	Relevant to claim No.
Y	FR,A,1 156 627 (RIETER) 19 May 1958 see the whole document ---	1-3,6,8, 9
Y	DE,A,38 22 472 (NEUWEG) 4 January 1990 see the whole document ---	1-3,6,8, 9
A	EP,A,0 088 589 (EATON) 14 September 1983 see the whole document ---	1,2,4,5, 7
A	US,A,4 403 814 (KOSS) 13 September 1983 see the whole document ---	1,8,9
A	US,A,2 226 524 (RUNGE) 24 December 1940 see the whole document ---	1,2,8,9
-/--		
<input checked="" type="checkbox"/> Further documents are listed in the continuation of box C. <span style="margin-left: 100px;"><input checked="" type="checkbox"/> Patent family members are listed in annex.</span>		
* Special categories of cited documents :		
*A* document defining the general state of the art which is not considered to be of particular relevance *E* earlier document but published on or after the international filing date *L* document which may throw doubts on priority claim(s) or which is cited to establish the publication date of another citation or other special reason (as specified) *O* document referring to an oral disclosure, use, exhibition or other means *P* document published prior to the international filing date but later than the priority date claimed	*T* later document published after the international filing date or priority date and not in conflict with the application but cited to understand the principle or theory underlying the invention *X* document of particular relevance; the claimed invention cannot be considered novel or cannot be considered to involve an inventive step when the document is taken alone *Y* document of particular relevance; the claimed invention cannot be considered to involve an inventive step when the document is combined with one or more other such documents, such combination being obvious to a person skilled in the art. *&* document member of the same patent family	
1 Date of the actual completion of the international search  <div style="text-align: center; font-weight: bold;">16 November 1994</div>	Date of mailing of the international search report  <div style="text-align: center; font-weight: bold; font-size: 1.2em;">29. 11. 94</div>	
Name and mailing address of the ISA European Patent Office, P.B. 5818 Patentlaan 2 NL - 2280 HV Rijswijk Tel. (+ 31-70) 340-2040, Tx. 31 651 epo nl, Fax (+ 31-70) 340-3016	Authorized officer  <div style="text-align: center; font-weight: bold;">Orthlieb, C</div>	

## INTERNATIONAL SEARCH REPORT

International Application No  
PCT/GB 94/02090

## C.(Continuation) DOCUMENTS CONSIDERED TO BE RELEVANT

Category *	Citation of document, with indication, where appropriate, of the relevant passages	Relevant to claim No.
A	US,A,3 517 976 (MCALLISTER) 30 June 1970 see the whole document ---	1
A	US,A,1 612 465 (PARSONS) 28 December 1926 see the whole document ---	1
A	US,A,4 164 063 (CENKO) 14 August 1979 see the whole document -----	1

1

# INTERNATIONAL SEARCH REPORT

Information on parent family members

International Application No

PCT/GB 94/02090

Patent document cited in search report	Publication date	Patent family member(s)	Publication date
FR-A-1156627		NONE	
DE-A-3822472	04-01-90	NONE	
EP-A-0088589	14-09-83	JP-A- 58166129 US-A- 4544054	01-10-83 01-10-85
US-A-4403814	13-09-83	NONE	
US-A-2226524		NONE	
US-A-3517976	30-06-70	NONE	
US-A-1612465		NONE	
US-A-4164063	14-08-79	NONE	