

AUSTRALIA
Patents Act 1990

043273

PATENT REQUEST: STANDARD PATENT

I/We, being the person(s) identified below as the Applicant, request the grant of a patent to the person identified below as the Nominated Person, for an invention described in the accompanying standard Complete Specification.

Full application details follow.

(71) Applicant: Mitsubishi Jukogyo Kabushiki Kaisha
and Churyo Engineering Kabushiki Kaisha
Address 5-1, Marunouchi 2-chome, Chiyoda-ku,
Tokyo, Japan and
60-1, Aza Kutanjo, Iwatsuka-cho,
Nakamura-ku, Nagoya-shi, Aichi-ken, Japan.

(70) Nominated Person: APPLICANT AS ABOVE.

Address

(54) Invention Title "SCROLL TYPE FLUID MACHINE"

(72) Name(s) of actual inventor(s) Toshiyuki Shikanai,
Takayuki Iio, Takahisa Hirano and Yoshiharu Morita.

(74) Address for service in Australia: KELVIN LORD AND
COMPANY, Patent and Trade Mark Attorneys, of, 4 Douro
Place, West Perth, Western Australia, 6005, AUSTRALIA.

Attorney Code: LD

BASIC CONVENTION APPLICATION(S) DETAILS

(31) Application Number	(33) Country	Country Code	(32) Date of Application
216169/1990	Japan	JP	August 16 1990

DATED THIS 8th DAY OF May 1991

MITSUBISHI JUKOGYO KABUSHIKI
KAISHA AND
CHURYOENGINEERING KABUSHIKI
KAISHA
By their Patent Attorneys
KELVIN LORD AND COMPANY
PERTH, WESTERN AUSTRALIA

kelvin

015591



Australia Patent Declaration Form

Forms 7 and 8

AUSTRALIA

Patents Act 1952

DECLARATION IN SUPPORT OF A CONVENTION OR NON-CONVENTION APPLICATION FOR A PATENT OR PATENT OF ADDITION

Name(s) of Applicant(s)

In support of the application made by MITSUBISHI JUKOGYO KABUSHIKI KAISHA

Title

for a patent for an invention entitled SCROLL TYPE FLUID MACHINERY

Name(s) and address(es) of person(s) making declaration

/We, Arata ISHIKAWA, General Manager of Patent & License Department, MITSUBISHI JUKOGYO KABUSHIKI KAISHA, 5-1, Marunouchi 2-chome, Chiyoda-ku, Tokyo, Japan

do solemnly and sincerely declare as follows:-

Country, filing date and name of Applicant(s) for the or each basic application

1. I am/we are the applicant(s) for the patent, or am/are authorised by the abovementioned applicant to make this declaration on its behalf.

2. The basic application(s) as defined by Section 141 of the Act was/were made in the following country or countries on the following date(s) by the following applicant(s) namely:-

in Japan on August 16, 1990
by MITSUBISHI JUKOGYO KABUSHIKI KAISHA and
in CHURYO ENGINEERING KABUSHIKI KAISHA 19
by _____

3. The said basic application(s) was/were the first application(s) made in a Convention country in respect of the invention the subject of the application.

Name(s) and address(es) of the or each actual inventor

4. The actual inventor(s) of the said invention is/are Toshiyuki SHIKANAI, Takayuki IIO, Takahisa HIRANO, and Yoshiharu MORITA whose addresses are as per attached.

See reverse side of this form for guidance in completing this part

5. The facts upon which the applicant(s) is/are entitled to make this application are as follows:-

The applicant is the assignee of the actual inventor(s).

DECLARED at Tokyo, Japan this 16th day of May, 1991
MITSUBISHI JUKOGYO KABUSHIKI KAISHA

Arata ISHIKAWA, General Manager of Patent & License Department



AU9176453

(12) PATENT ABRIDGMENT **(11) Document No. AU-B-76453/91**
(19) AUSTRALIAN PATENT OFFICE **(10) Acceptance No. 643273**

- (54) Title
SCROLL TYPE FLUID MACHINE
- (51)⁵ International Patent Classification(s)
F01C 001/02 F01C 021/00 F04C 002/02 F04C 015/00
F04C 018/02 F04C 029/00
- (21) Application No. : 76453/91 (22) Application Date : 10.05.91
- (30) Priority Data
- (31) Number (32) Date (33) Country
2-216169 16.08.90 JP JAPAN
- (43) Publication Date : 20.02.92
- (44) Publication Date of Accepted Application : 11.11.93
- (71) Applicant(s)
MITSUBISHI JUKOGYO KABUSHIKI KAISHA; CHURYO ENGINEERING KABUSHIKI KAISHA
- (72) Inventor(s)
TOSHIYUKI SHIKANAI; TAKAYUKI IIO; TAKAHISA HIRANO; YOSHIHARU MORITA
- (74) Attorney or Agent
KELVIN LORD & COMPANY , 4 Douro Place, WEST PERTH WA 6005
- (56) Prior Art Documents
GB 2132276
US 4824346
- (57) Claim
1. A scroll type fluid machine comprising a housing sealed by a substantially cup-shaped main body and a front cover assembly, a stationary scroll and a revolving scroll provided in said housing and arranged to engage with each other, said stationary and revolving scrolls having a respective end plate with a respective spiral wrap provided on a respective inner side of each said end plate, said stationary scroll fixed to a bottom side of said housing and said revolving scroll able to revolve in an orbital motion whilst its axial rotation is restrained by rotation restraining means, low pressure chamber forming means which together with said stationary scroll is secured to said housing by bolt means from outside said housing, and a hole provided in said low pressure chamber forming means, wherein said low pressure chamber forming means has an outer peripheral surface sealing with an inner peripheral surface

(11) AU-B-76453/91

-2-

(10) 643273

of said cup-shaped main body and said low pressure chamber forming means is disposed at the outside of said end plate of said stationary scroll to partition the inside of said housing into a first low pressure chamber and a high pressure chamber, and said hole communicates at a first end thereof with a discharge port provided at a central part of said end plate of said stationary scroll and said hole opens at a second end thereof to said high pressure chamber to enable said high pressure chamber and said ^{discharge port} ~~first low~~ ~~pressure chamber~~ to communicate, such that said high pressure chamber is positioned toward said bottom side of said housing and a second low pressure chamber is formed between said end plate of said stationary scroll and said high pressure chamber by said low pressure chamber forming means, and said second low pressure chamber is arranged to communicate with said first low pressure chamber.

AUSTRALIA

PATENTS ACT 1990

COMPLETE SPECIFICATION
FOR A STANDARD PATENT
(Original)

APPLICATION NUMBER:
LODGED:

COMPLETE SPECIFICATION LODGED:
ACCEPTED:
PUBLISHED:

643273

RELATED ART:

NAME OF APPLICANT:

MITSUBISHI JUKOGYO KABUSHIKI
KAISHA and
CHURYO ENGINEERING KABUSHIKI
KAISHA

ACTUAL INVENTOR(S):

TOSHIYUKI SHIKANAI
TAKAYUKI IIO
TAKAHISA HIRANO AND
YOSHIHARU MORITA

ADDRESS FOR SERVICE:

KELVIN LORD AND COMPANY
4 Douro Place
West Perth
WA 6005

INVENTION TITLE:

"SCROLL TYPE FLUID MACHINE"

DETAILS OF ASSOCIATED PROVISIONAL APPLICATIONS: NOS:

The following statement is a full description of this invention including the best method of performing it known to me/us:-

STANDARD/1



1
2
3
4
5
6
7
8
9
10
11
12
13
14
15
16
17
18
19
20
21
22
23
24
25
26
27
28
29
30

The present invention relates to a scroll type fluid machine used as a compressor, an expansion machine and the like.

Fig. 3 shows an example of a conventional scroll type compressor of this sort.

In Fig. 3, a housing 1 consists of a cup-shaped main body 2, a front end plate 4 which is clamped to the main body 2 with bolts (not shown), and a front cover 6 which is clamped to the front end plate 4 with a bolt 5.

A rotary shaft 7 extends through the front cover 6 and is rotatably supported by the housing 1 through a bearing 8, provided between the front cover 6 and the rotary shaft 7, and a bearing 9 provided between a boss 7a thereof and the front end plate 4.

A stationary scroll 10 and a revolving scroll 14 are housed inside the housing 1.

The stationary scroll 10 is provided with an end plate 11 and a spiral wrap 12 disposed on the inner surface thereof. The outer peripheral surface of the end plate 11 is brought into close contact with the inner peripheral surface of the cup-shaped main body 2 and clamped with a bolt 13 thereto. The stationary scroll 10 is fixed to the bottom side of the housing 1. Thus, a high pressure chamber 31 is delimited on the outside of the end plate 11, and a low pressure chamber 32 is delimited on the inside thereof.

The revolving scroll 14 is provided with an end plate 15 and a spiral wrap 16 disposed on the inside surface



1
2
3
4
5
6
7
8
9
10
11
12
13
14
15
16
17
18
19
20
21
22
23
24
25
26
27
28
29
30

thereof.

The spiral wrap 16 has substantially the same configuration as the spiral wrap 12.

The revolving scroll 14 and the stationary scroll 10 are eccentric from each other by the radius of revolution. The revolving scroll 14 and the stationary scroll 10 are engaged with each other with their respective spiral wraps 16 and 12 being rotationally displaced 180° from each other as shown in Figure 3.

A tip seal 17 is disposed on an end surface of the spiral wrap 12. The tip seal 17 is in close contact with the inner surface of the end plate 15. A tip seal 18 is embedded in the end surface of the spiral wrap 16. The tip seal 18 is in close contact with the inner surface of the end plate 11. The side surfaces of the spiral wraps 12 and 16 are brought into linear contact with each other at a plurality of locations. In this way, a plurality of closed small chambers 19a and 19b are delimited. The closed small chambers 19a and 19b form an approximate point symmetry with respect to the centre of the spiral wraps 12 and 16.

A bushing 21 is rotatably fitted into a cylindrical boss 20. The cylindrical boss 20 projects from the central part of the outer surface of the end plate 15 of the revolving scroll 14 through a rotary bearing 23. An eccentric pin 25 projects from an inner end of the rotary shaft 7 and is rotatably fitted into an eccentric hole 24 bored in the bushing 21. Further, a balance weight 27 is fixed to this bushing 21.



1
2
3
4
5
6
7
8
9
10
11
12
13
14
15
16
17
18
19
20
21
22
23
24
25
26
27
28
29
30

A rotation restraining mechanism 26 for restraining axial rotation is arranged between the outer peripheral edge of the outer surface of the end plate 15 and the inner surface of the front end plate 4. The rotation restraining mechanism also acts as a thrust bearing.

A sub-balance weight 28 is clamped on the boss 7a of the rotary shaft 7.

Thus, when the rotary shaft 7 is rotated, the revolving scroll 14 is driven through the eccentric pin 25, the bushing 21, the rotary bearing 23 and the boss 20, and the revolving scroll 14 revolves in an orbital motion while being restrained from rotating on its axis by means of the rotation restraining mechanism 26.

When the revolving scroll 14 revolves in an orbital motion, the linear contact portion between the spiral wraps 12 and 16 gradually moves toward the centre of the spiral. As a result, the closed small chambers 19a and 19b move toward the centre of the spiral while reducing the volumes thereof. In keeping with this, gas sucked into the low pressure chamber 32 through a suction port (not shown) is taken into the closed small chambers 19a and 19b from opening portions at the outer peripheral ends of the spiral wraps 12 and 16 and reaches a central chamber 22 while being compressed.

Then, the gas passes therefrom through a discharge port 29 bored in the central part of the end plate 11 of the stationary scroll 10 and pushes a discharge valve 30 open to discharge into the high pressure chamber 31, and flows out through a discharge port (not shown).



1
2
3
4
5
6
7
8
9
10
11
12
13
14
15
16
17
18
19
20
21
22
23
24
25
26
27
28
29
30

In the above-mentioned conventional scroll type compressor, there is a risk that a high pressure gas in the above-mentioned high pressure chamber 31 can act on the outer surface of the end plate 11 of the stationary scroll 10 during operation, thereby deforming the end plate 11 so that it becomes depressed at the centre thereof.

When the end plate 11 becomes thus deformed, problems such as galling, abnormal friction and seizure on the inner surface of the end plate 11, particularly between the central part thereof and the tip surface of the spiral wrap 16 of the revolving scroll 14 and damage at the tip portion of the spiral wrap 16 can occur.

This has necessitated a counter-measure to be taken whereby the thickness of the end plate 11 is increased or the tooth height at the central part of the spiral of the spiral wrap 16 is made lower than at other parts.

However, such a counter-measure results in a lowering of efficiency.

The present invention seeks to provide a scroll type fluid machine which addresses the above-described problems associated with conventional scroll type machines.

In accordance with one aspect of the present invention there is provided a scroll type fluid machine comprising a housing sealed by a substantially cup-shaped main body and a front cover assembly, a stationary scroll and a revolving scroll provided in



1
2
3
4
5
6
7
8
9
10
11
12
13
14
15
16
17
18
19
20
21
22
23
24
25
26
27
28
29
30

said housing and arranged to engage with each other, said stationary and revolving scrolls having a respective end plate with a respective spiral wrap provided on a respective inner side of each said end plate, said stationary scroll fixed to a bottom side of said housing and said revolving scroll able to revolve in an orbital motion whilst its axial rotation is restrained by rotation restraining means, low pressure chamber forming means which together with said stationary scroll is secured to said housing by bolt means from outside said housing, and a hole provided in said low pressure chamber forming means, wherein said low pressure chamber forming means has an outer peripheral surface sealing with an inner peripheral surface of said cup-shaped main body and said low pressure chamber forming means is disposed at the outside of said end plate of said stationary scroll to partition the inside of said housing into a first low pressure chamber and a high pressure chamber, and said hole communicates at a first end thereof with a discharge port provided at a central part of said end plate of said stationary scroll and said hole opens at a second end thereof to said high pressure chamber to enable said high pressure chamber and said ^{discharge port} ~~first low pressure chamber~~ to communicate, such that said high pressure chamber is positioned toward said bottom side of said housing and a second low pressure chamber is formed between said end plate of said stationary scroll and said high pressure chamber by said low pressure chamber forming means, and said second low pressure chamber is arranged to communicate with said first low pressure chamber.



1
2
3
4
5
6
7
8
9
10
11
12
13
14
15
16
17
18
19
20
21
22
23
24
25
26
27
28
29
30

In the present invention, the low pressure in the low pressure chamber is applied to the outer surface of the end plate of the stationary scroll with the construction described above. Therefore, deformation of the end plate is prevented or reduced.

5
3
0
7
5
0
0



1
2
3
4
5
6
7
8
9
10
11
12
13
14
15
16
17
18
19
20
21
22
23
24
25
26
27
28
29
30

As it is evident from the above description, in the present invention the low pressure in the low pressure chamber is applied to the outer surface of the end plate of the stationary scroll, thus preventing or reducing deformation of the end plate.

As a result, it is possible to prevent abnormal friction, seizure and galling between the inner surface of the end plate of the stationary scroll and the tip surface of the spiral wrap of the revolving scroll and damage to the spiral wrap, thus improving reliability of the scroll type fluid machine.

The present invention will now be described, by way of example, with reference to the accompanying drawings, in which:-

Fig. 1 is a longitudinal sectional view showing a first embodiment of a scroll type fluid machine in accordance with the present invention;

Fig. 2 is a partial longitudinal sectional view showing a second embodiment of a scroll type fluid machine in accordance with the present invention; and

Fig. 3 is a longitudinal sectional view of a conventional scroll type compressor.

Preferred embodiments of the present invention will be described in detail hereafter illustratively with reference to the drawings.

Figures 1 and 2 and the following description of the preferred embodiments use the same reference numerals that are used in Figure 3 and the description of the conventional scroll type compressor to denote



1
2 corresponding parts. Accordingly, the description of
3 these parts as described with reference to the
4 conventional scroll type compressor and Fig. 3 applies
5 in like manner to the preferred embodiments of Figs. 1
6 and 2 and so is not herein repeated. Thus, the
7 description of the preferred embodiments of Figs. 1 and
8 2 which follows is directed to the differences between
9 these embodiments and the conventional scroll type
10 compressor previously described herein.

11 Fig. 1 shows a first embodiment of a scroll type fluid
12 machine in accordance with the present invention.

13 A low pressure chamber forming unit 33 is disposed on
14 the outside of an end plate 11 of a stationary scroll
15 10, and is clamped to a cup-shaped main body 2 together
16 with the stationary scroll 10 by means of a bolt 13.

17 The outer peripheral surface of the unit 33 is
18 installed on an inner peripheral surface of the
19 cup-shaped main body 2 through a seal ring 35 so as to
20 form an airtight structure. In this way, the inside of

21 the housing 1 of the scroll type fluid machine is
22 partitioned into a low pressure chamber 32 and a high
23 pressure chamber 31 by means of the unit 33. Further,
24 a low pressure chamber 34 is delimited between the end

25 plate 11 of the stationary scroll 10 and the high
26 pressure chamber 31 by means of the unit 33. The low ^{pressure chamber 34 communicates with the low.}
27 pressure chamber 32 via a through hole 36.

28 A hole 37, which at one end thereof communicates with a
29 discharge port 29, is bored at the central part of the
30 unit 33.



1
2
3
4
5
6
7
8
9
10
11
12
13
14
15
16
17
18
19
20
21
22
23
24
25
26
27
28
29

A tip of a cylindrical boss 38 (of the unit 33) which projects toward the end plate 11 around the hole 37 is attached onto the outer surface of the end plate 11 via a seal ring 39 so as to form an airtight structure. Further, a discharge valve 30 opens and closes the outlet end of the hole 37. This outlet end opens to the high pressure chamber 31. The hole 37 thus enables the discharge port 29 and the high pressure chamber 31 to communicate. The remaining construction of the scroll type fluid machine of the first embodiment shown in Fig. 1 is similar to that of the conventional scroll type compressor shown in Fig. 3. Accordingly, it is to be understood that the description of this remaining construction that was described with reference to the conventional scroll type compressor and Fig. 3 applies in like manner to the preferred embodiments of Fig. 1. When the scroll type fluid machine shown in Fig. 1 is in operation, a low pressure gas sucked into the low pressure chamber 32 enters the low pressure chamber 34 via the through hole 36. Accordingly, the low pressure gas in the low pressure chamber 34 acts on the outer surface of the end plate 11 of the stationary scroll 10, and the pressing force applied to the end plate 11 becomes substantially less as compared with a conventional scroll type compressor, thereby preventing or reducing deformation of the end plate 11. Fig. 2 shows a second embodiment of a scroll type fluid machine in accordance with the present invention, wherein



1

2

the hole 37 is enlarged, the discharge valve 30 is

3

disposed at the bottom of the hole 37, and the

10
11
12

13
14
15
16



1
2 outlet of the discharge port 29 is opened and closed by
3 means of the discharge valve 30.

4 In the second embodiment of the scroll type fluid machine
5 shown in Fig. 2, the top clearance volume is reduced and
6 performance of the machine may be improved.

7 The remaining construction of the scroll type fluid machine
8 of the second embodiment shown in Figure 2 is similar to
9 that of the conventional scroll type compressor shown in
10 Fig. 3 and the preferred embodiment of the scroll type fluid
11 machine shown in Fig. 1.

12 Accordingly, it is to be understood that the description of
13 this remaining construction that was described with
14 reference to the conventional scroll type compressor of Fig.
15 3 and the preferred embodiment of Fig. 1 applies in like
16 manner to the preferred embodiment of Fig. 2.

17 The remainder of the operation of the scroll type fluid
18 machines of the first and second embodiments shown in Figs.
19 1 and 2, respectively, is similar to that of the
20 conventional scroll type compressor shown in Fig. 3.

21 Modifications and variations such as would be apparent to a
22 skilled addressee are deemed within the scope of the present
23 invention.

24
25
26
27
28
29
30



The Claims defining the invention are as follows:

1. A scroll type fluid machine comprising a housing sealed by a substantially cup-shaped main body and a front cover assembly, a stationary scroll and a revolving scroll provided in said housing and arranged to engage with each other, said stationary and revolving scrolls having a respective end plate with a respective spiral wrap provided on a respective inner side of each said end plate, said stationary scroll fixed to a bottom side of said housing and said revolving scroll able to revolve in an orbital motion whilst its axial rotation is restrained by rotation restraining means, low pressure chamber forming means which together with said stationary scroll is secured to said housing by bolt means from outside said housing, and a hole provided in said low pressure chamber forming means, wherein said low pressure chamber forming means has an outer peripheral surface sealing with an inner peripheral surface of said cup-shaped main body and said low pressure chamber forming means is disposed at the outside of said end plate of said stationary scroll to partition the inside of said housing into a first low pressure chamber and a high pressure chamber, and said hole communicates at a first end thereof with a discharge port provided at a central part of said end plate of said stationary scroll and said hole opens at a second end thereof to said high pressure chamber to enable said high pressure chamber and said first low pressure chamber to communicate, such that said high pressure chamber is positioned toward said bottom side of said housing and a second low pressure chamber is formed

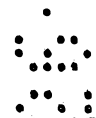
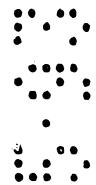
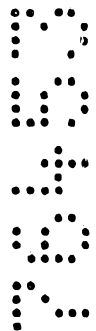

1
2 between said end plate of said stationary scroll and said
3 high pressure chamber by said low pressure chamber forming
4 means, and said second low pressure chamber is arranged to
5 communicate with said first low pressure chamber.

6 2. A scroll type fluid machine according to Claim 1,
7 wherein said low pressure chamber forming means is provided
8 with a cylindrical boss which projects toward said end plate
9 of said stationary scroll around said hole and is attached
10 to the outside surface of said end plate of said stationary
11 scroll by first seal means.

12 3. A scroll type fluid machine according to Claim 1 or 2,
13 wherein discharge valve means is provided at said second end
14 of said hole.

15 4. A scroll type fluid machine according to Claim 1 or 2,
16 wherein said hole is of enlarged size and discharge valve
17 means is provided at said discharge port near said first end
18 of said hole.

19 5. A scroll type fluid machine according to any one of
20 Claims 1 to 4, wherein second seal means is provided between
21 said outer peripheral surface of said low pressure chamber
22 forming means and said inner peripheral surface of said
23 cup-shaped main body.

24 6. A scroll type fluid machine substantially as
25 hereinbefore described with reference to Fig. 1 or Fig. 2 of
26 the accompanying drawings.



1
2
3
4
5
6
7
8
9
10
11
12
13
14
15
16
17
18
19
20
21
22
23
24
25
26
27
28
29

- 12a -
DATED MAY 26 1993
MITSUBISHI JUKOGYO KABUSHIKI
KAISHA and
CHURYO ENGINEERING KABUSHIKI
KAISHA
By their Patent Attorneys
KELVIN LORD AND COMPANY
PERTH, WESTERN AUSTRALIA.

5
2
P

5
3
P

5
P



30

7. ABSTRACT

According to the present invention, there is provided a scroll type fluid machinery in which a stationary scroll and a revolving scroll provided with spiral wraps set up on end plates, respectively, are engaged with each other and housed in a housing, the stationary scroll is fixed to the housing, and the revolving scroll is made to revolve in a solar motion while checking the rotation on its axis by means of a mechanism for checking rotation on its axis, wherein a low pressure chamber forming unit which partitions the inside of the housing into a low pressure chamber and a high pressure chamber of above-mentioned machinery is disposed on the outside of the end plate of the stationary scroll, and a low pressure chamber which communicates with the low pressure chamber is formed between the end plate of the stationary scroll and the high pressure chamber by means of this low pressure chamber forming unit, thereby to prevent or reduce deformation of the end plate of the stationary scroll.



10 5 91 76490

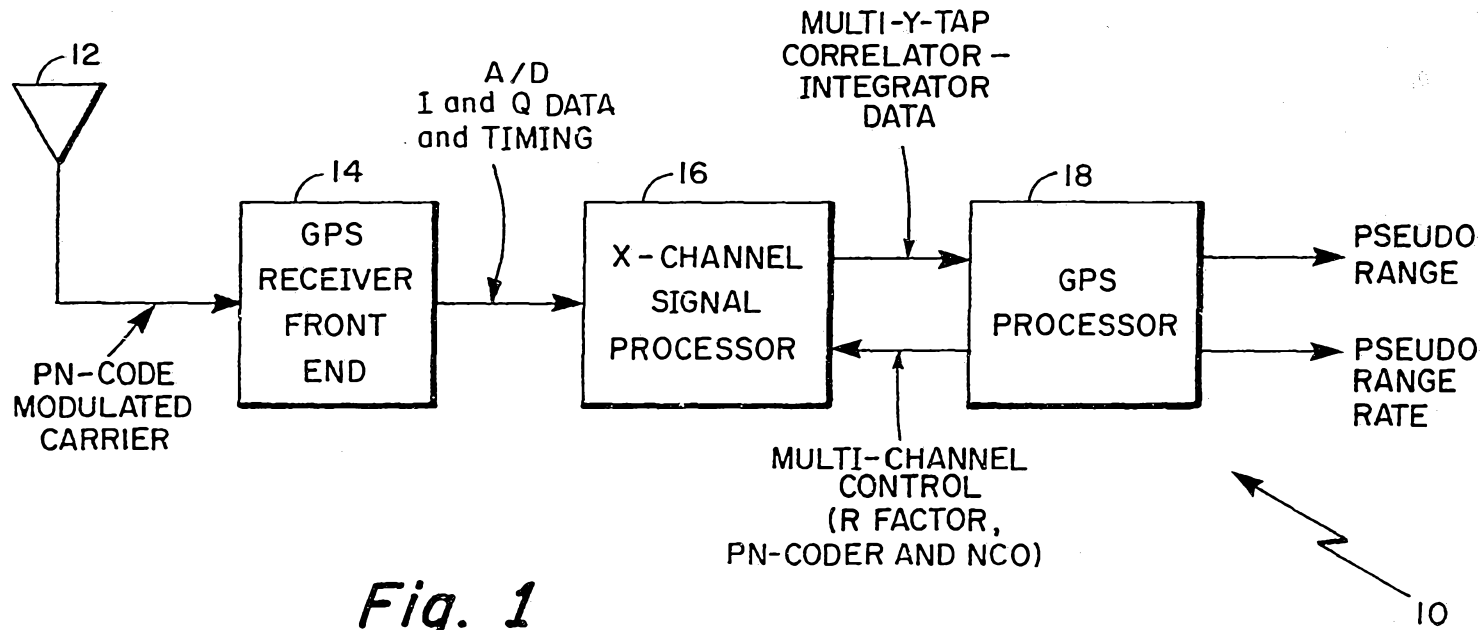
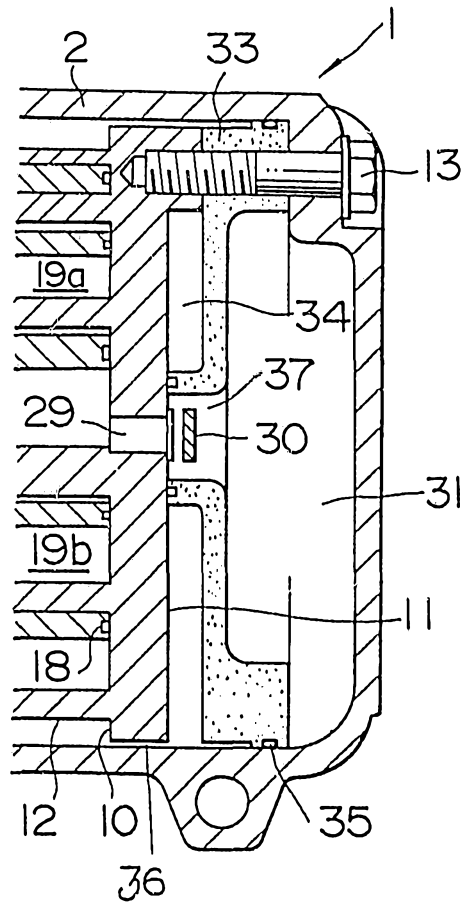

Fig. 1

FIG. 2



28 593 76453

FIG. 3

