



US00D960783S

(12) **United States Design Patent** (10) **Patent No.:** **US D960,783 S**
Gunnarson (45) **Date of Patent:** **** Aug. 16, 2022**

(54) **BUMPER FOR A VEHICLE**
(71) Applicant: **VOLVO CAR CORPORATION**,
Gothenburg (SE)
(72) Inventor: **Anders Gunnarson**, Kullavik (SE)
(73) Assignee: **VOLVO CAR CORPORATION**,
Gothenburg (SE)
(**) Term: **15 Years**
(21) Appl. No.: **29/760,601**
(22) Filed: **Dec. 2, 2020**

D809,981 S * 2/2018 Seo D12/169
D821,941 S * 7/2018 Mack D12/169
D822,552 S * 7/2018 Platto D12/169
D832,744 S * 11/2018 Wheel D12/91
D837,692 S * 1/2019 Badstuebner D12/91
D840,273 S * 2/2019 Battams D12/91
D840,290 S * 2/2019 Frascella D12/164
D864,059 S * 10/2019 Melville-Brown D12/196
D908,557 S * 1/2021 Arias D12/169

(30) **Foreign Application Priority Data**
Jul. 9, 2020 (WO) WIPO95984
(51) **LOC (13) Cl.** **12-16**
(52) **U.S. Cl.** **D12/169**
USPC **D12/169**
(58) **Field of Classification Search**
USPC D12/169, 164, 196, 171, 86, 90-92;
296/180.1, 180.2
CPC B60R 19/02; B60R 19/04; B62D 25/08
See application file for complete search history.

OTHER PUBLICATIONS

NetCarShow.com, Volvo, Design Name: Concept Coupe, Year of Introduction: 2019.
NetCarShow.com, Volvo, Design Name: V60, Year of Introduction: 2013.
NetCarShow.com, Volvo, Design Name: XC90, Year of Introduction: 2014.

* cited by examiner

Primary Examiner — Melody N Brown
(74) *Attorney, Agent, or Firm* — Berenato & White, LLC

(57) **CLAIM**

The ornamental design for a bumper for a vehicle, as shown and described.

DESCRIPTION

FIG. 1 is a front elevational view of a bumper for a vehicle showing my new design;
FIG. 2 is a right, front perspective view thereof;
FIG. 3 is a right, rear perspective view thereof;
FIG. 4 is a right side elevational view thereof;
FIG. 5 is a left side elevational view thereof;
FIG. 6 is a top plan view thereof;
FIG. 7 is a bottom plan view thereof; and,
FIG. 8 is a rear elevational view thereof.

1 Claim, 8 Drawing Sheets

(56) **References Cited**
U.S. PATENT DOCUMENTS
D751,006 S * 3/2016 Futschik D12/164
D782,936 S * 4/2017 Wheel D12/91
D784,855 S * 4/2017 Wheel D12/91
D802,496 S * 11/2017 Mainville D12/169
D807,788 S * 1/2018 Hatton D12/91
D807,789 S * 1/2018 Wheel D12/91
D807,800 S * 1/2018 Wheel D12/169

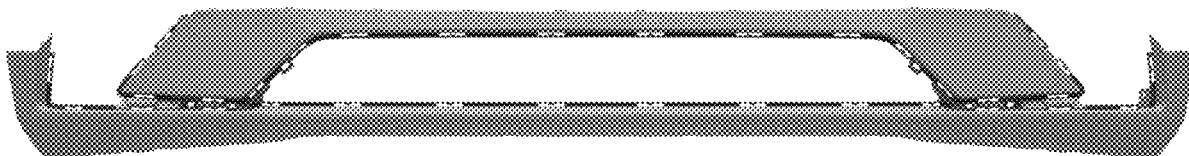

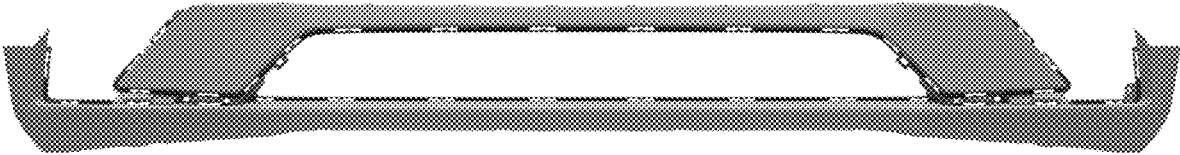

FIG. 1

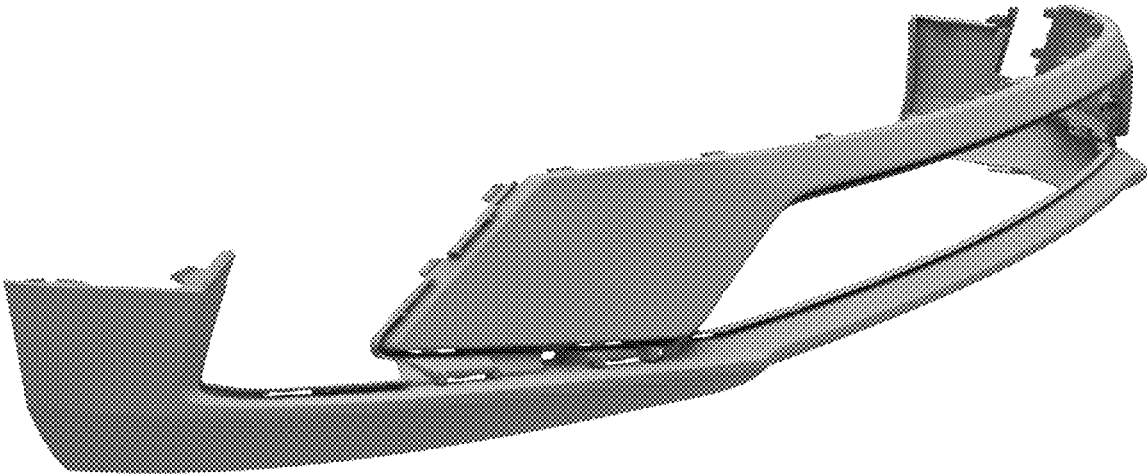

FIG. 2

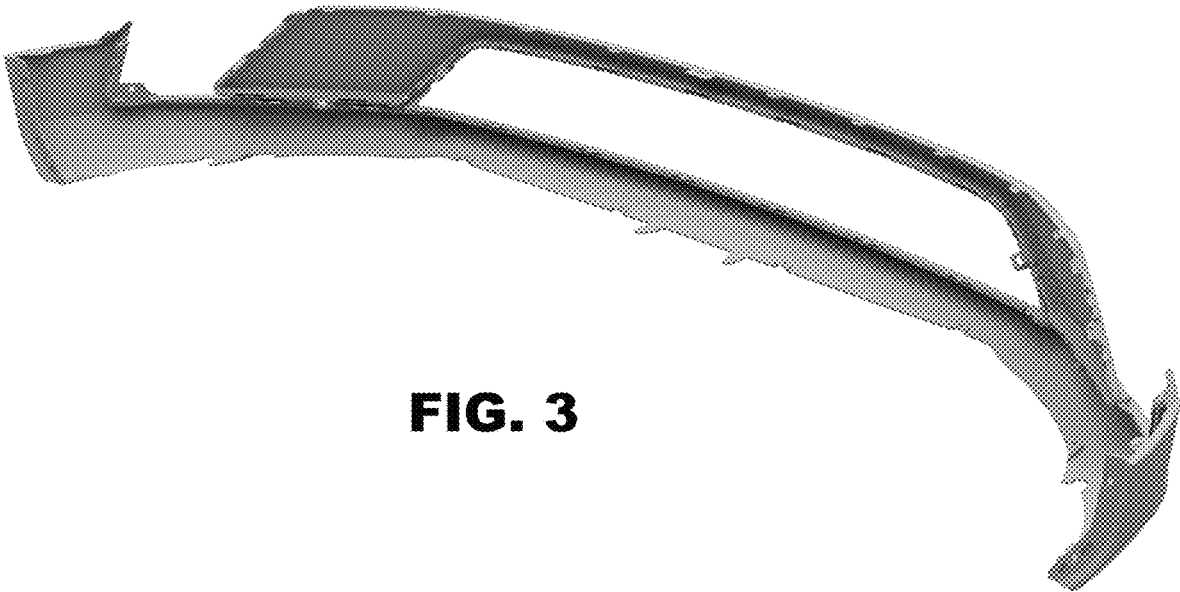

FIG. 3

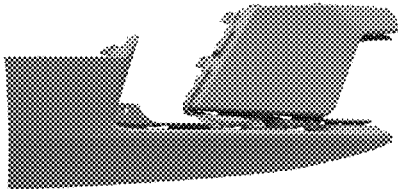

FIG. 4

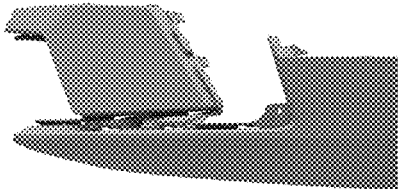

FIG. 5

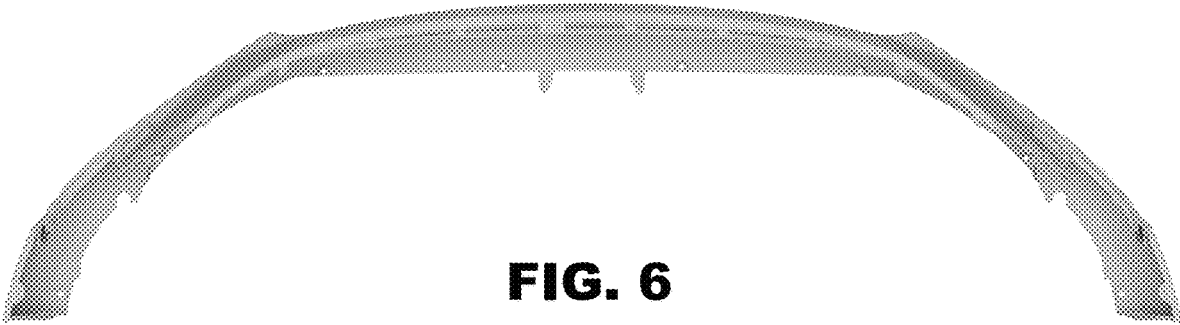

FIG. 6

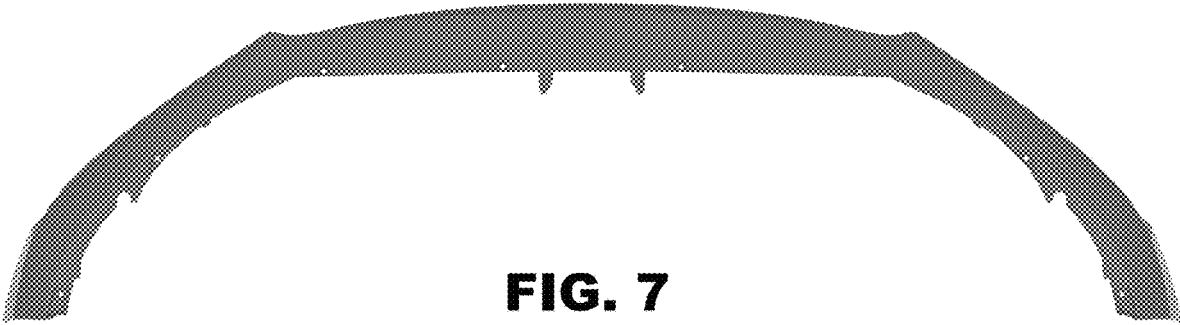

FIG. 7

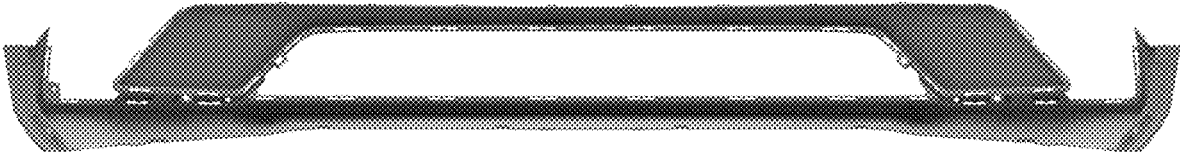

FIG. 8