

H. P. CONLON.  
DISINFECTING APPARATUS APPLICABLE TO MANHOLES.  
APPLICATION FILED APR. 5, 1918.

1,282,542.

Patented Oct. 22, 1918.

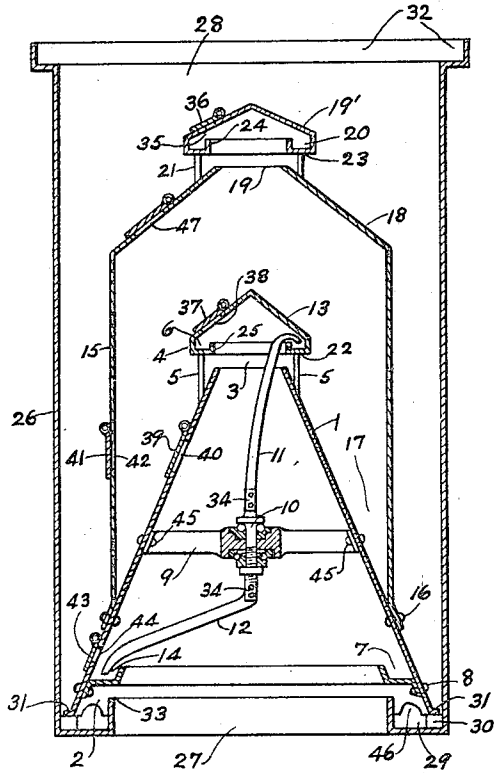

INVENTOR  
Hugh Paul Conlon  
BY  
*H. P. Conlon*  
HIS ATTORNEYS

# UNITED STATES PATENT OFFICE.

HUGH PAUL CONLON, OF CORK, IRELAND.

DISINFECTING APPARATUS APPLICABLE TO MANHOLES.

1,282,542.

Specification of Letters Patent.

Patented Oct. 22, 1918.

Application filed April 5, 1918. Serial No. 226,823.

*To all whom it may concern:*

Be it known that I, HUGH PAUL CONLON, a subject of the King of Great Britain, residing at 8 Alfred street, Cork, Co Cork, Ireland, have invented certain new and useful Improvements in Disinfecting Apparatus Applicable to Manholes and Ventilators of Sewers or Sewage-Receptacles, of which the following is a specification.

10 This invention relates to disinfecting apparatus for application to man-holes and ventilators of sewers or sewage receptacles for the purpose of preventing the arising of objectionable smells and has for its object  
15 to provide simplified, efficient and cheap means for such purpose; and a further object is to partially or wholly destroy germs that escape through man-holes or ventilators that are used in connection with such  
20 sewerage systems.

According to my said invention, the said apparatus is made to suit any man-hole or ventilator of the kind described, and comprises an inner conical chamber having open  
25 ends top and bottom, the smaller open end being at the top and having a fluid containing cap held clear of this smaller open end by means of supporting legs detachably connected to this end portion of said  
30 conical chamber. The bottom of this cap is provided with an annular well for containing fluid having a disinfecting nature. Circumferentially positioned in the interior and lower and larger end portion of this conical  
35 chamber is another annular well for containing a suitable disinfecting fluid. In or about midway in said conical chamber is a cross-piece or bracket bearing in which is rotatably positioned a collared shaft or pivot  
40 having at each end one or more blades arranged at suitable angles so as to be driven by the draft of air which passes constantly through the man-hole or ventilator; the free end or ends of the upper blade or blades  
45 dipping into the disinfecting fluid in the well in said cap, and the free end or ends of the lower blade or blades dipping into the lower well, this wind-mill type of apparatus being adapted to constantly agitate the fluid  
50 in both wells so that more pronounced odors are given off from said disinfecting fluid. Over said conical chamber is concentrically placed an outer cylindrical chamber having

its lower end fixed to the lower end portion of said conical chamber so as to form a re-  
55 ceptacle or well for containing a suitable disinfecting fluid, the top of this outer chamber being coned and open and provided with a similar fluid containing cap having  
60 an annular well for a suitable disinfectant and being supported on and clear of the top of said outer chamber. The inner diameter of annular well of each of said caps is larger than the diameter of the opening over  
65 which it is placed.

The apparatus rests in a hanger or container comprising a vertically positioned cylinder with open ends, the lower end having an annular well provided with spaced blocks or rests to receive arms or flanged  
70 projections on the lower end of said conical chamber for bolting the latter into said annular well which is filled with water thus making an airtight joint so that the draft  
75 and fumes from the sewer or the like pass up through the conical chamber and out of its top into the outer cylindrical chamber and thence through the opening at the top of the latter to the atmosphere, and at  
80 the same time this draft of foul or impure air is amalgamated or mixed with the odors given off from the disinfectants contained in the annular wells and receptacle  
85 herein referred to so that the gases reaching the atmosphere are rid of objectionable smells which are a source of danger to the public health. Said hanger or container rests in the man-hole or ventilator of the sewer or the like and over such may be positioned the usual man-hole grating so that  
90 the inflowing surface water reaches and overflows the annular well in bottom of said container whence it flows into the sewer or the like. In combination with my said apparatus, I may use any suitable disinfectants  
95 or disinfecting fluids for the purposes set forth.

Adjacent to or near to each well or receptacle, filling or inspection holes may be made and adjustably covered by means of  
100 sliding panels or hinged covers or the like, so that the apparatus may be inspected and the wells filled when desired.

The said apparatus constructed and arranged in accordance with my said inven-  
105 tion is more fully described hereinafter and

is illustrated in the accompanying drawing, and the same reference numbers are used for the same parts throughout.

The drawing shows a sectional elevation of the said apparatus.

The inner conical chamber 1 has an open end 2 and an open top 3, the smaller open end at the top having an annular fluid containing cap 4 held clear of the smaller open end by means of supporting legs such as 5 detachably connected to this end portion of said conical chamber by means of bolts or the like, not shown. The bottom of this cap is provided with an annular well 6 for containing any suitable disinfecting fluids. Circumferentially positioned in the interior and lower and larger end portion of this conical chamber is another annular well 7 for containing a similar disinfecting fluid, this annular well being suitably fixed or riveted at 8 to the conical chamber 1. In or about midway in the conical chamber 1 is a cross-piece, or bracket bearing 9 provided preferably with anti friction bearings such as shown, and in which is rotatably positioned a collared shaft or pivot 10 having fixed at the upper end thereof a fan like blade 11 or blades as the case may be, said shaft having at its lower end a similar fan like blade 12, both of which are arranged at suitable angles or pitches so as to be driven by the draft of air which constantly passes through the man-hole or ventilator, the free end or ends of the upper blade 11 being bent over at 13 to dip into the disinfecting fluid in the well 6, and the free end or ends of the lower blade or blades 12 being bent at 14 and adapted to dip into the lower well 7, this wind-mill type of apparatus being adapted to constantly agitate fluid in the wells 6 and 7 so that more pronounced odors are given off from the said disinfecting fluid. Over said conical chamber is concentrically placed an outer cylindrical chamber 15 having its lower end at 16 suitably riveted or fixed to the lower end portion of said conical chamber so as to form a receptacle or well 17 for containing a suitable disinfecting fluid, the top of this outer chamber being coned at 18 and open at the top at 19 and provided with a similar and annular fluid containing cap 19' having an annular well 20 for receiving a suitable disinfectant, and like the cap 4 is supported on and clear of the top 19 of the outer chamber 15 by similar legs 21 which are bolted or otherwise detachably connected to the conical top 18. The legs 5 and 21 are fixed at 22 and 23 to their respective caps which latter are suitably shaped as shown. The inner diameter of the annular well 20 at 24 is larger than the diameter of the opening at 19, and the inner diameter of the annular well 6 at 25 is larger than the opening 3 so that the fumes from sewer or the like are

better guided into each cap or respective wells thereof. This apparatus rests in a suitable cylindrical hanger or container 26 comprising the vertically positioned cylinder 26 as shown with an open bottom end at 27 and an open top at 28, the lower end having an annular well 29 provided with blocks 30 which are spaced at intervals to form a rest on which is supported at 31 the feet or arms or flanged projections, as the case may be, of the conical chamber 1 for bolting this conical chamber into the annular well 29 which is filled with water thus making an air-tight joint so that the draft or fumes from the sewer or the like passes up through the conical chamber 1 through the opening 27 and out at the top 3 into the cap 4 and into the outer cylindrical chamber 15 and thence through the opening 19 into the cap 19' and thence into the atmosphere through the openings 28, and at the same time this draft of foul or impure air is amalgamated or mixed with the odors given off from the disinfectants contained in the said annular wells and the receptacle or well 17 so that the gases reaching the atmosphere are rid of objectionable smells which are a source of danger to the public health. The hanger or container 26 rests in the man-hole or ventilator of the sewer or the like, and over such may be positioned at 32 the usual and known type of man-hole grating so that inflowing surface water reaches and overflows the annular well 29 in the bottom of said container whence the water flows over the top of this well at 33 into the sewer or the like through the opening 27. The fan like blades 11 and 12 are suitably fixed at 34 to the end of the shaft or spindle 10 by bolting thereto or by riveting to such. Adjacent to or near to the annular well 20 is a filling or inspection hole 35 which is adjustably covered by means of a suitable cover such as 36 which may be hinged to the cap 19' or may be slidably fitted thereto as a panel over the inspection hole 35. A similar cover 37 is fitted over an inspection hole 38 in the cap 4, and a similar cover 39 is fitted over an inspection hole 40 in the conical chamber 1 above the disinfectant in the well or receptacle 17, and about opposite the cover 39 a similar cover 41 is fitted over the inspection hole 42; and above the annular well 7 a similar cover 43 is fitted over the inspection hole 44, all of the covers and inspection holes including such shown at 47 in the coned top 18 being arranged so that the apparatus may be inspected and the wells or receptacles filled when desired. The cross-piece or supporting bracket 9 in which is centrally and vertically positioned the shaft 10, is suitably fixed at 45 inside of and about intermediate of the height of the inner conical chamber 1 by means of riveting thereto or by other suitable means.

In combination with my said apparatus, I may use any suitable disinfectants or disinfecting fluids for the purposes set forth; and the constructional details of the said apparatus may be slightly varied without departing from the nature or scope of the invention.

The hanger or container 26 is preferably enlarged or shaped as shown at 32 for the purpose set forth. The sides of the open end 2 of the conical chamber 1 at 46 are recessed or notched out preferably as shown so that the surface water may have an unrestricted flow into the well 9 and thence through the opening 27 into the sewer or the like.

I claim as my invention:

1. A disinfecting apparatus comprising an open-ended cylindrical shell, a trough in the larger end thereof, a cap spaced from the smaller end of the cylindrical shell, a trough secured in the said cap, a shaft and bearing therefor within the cylindrical shell, and blades fixed to the said shaft and adapted at their ends to extend into the said troughs.

2. A disinfecting apparatus comprising an open-ended conical shell, a trough at the larger end thereof, a cap spaced from the smaller end thereof, a trough in the said cap, a bracket secured within the cylindrical shell, a shaft and a bearing therefor mounted in the said bracket, a blade secured at one end to the said shaft and at its opposite end extending into the trough in the said cap, and a blade also secured at one end thereof to the said shaft at its opposite end extending into the trough at the inner end of the conical shell.

3. A disinfecting apparatus comprising a casing, a trough secured to the said casing interiorly and at one end thereof, an open-ended conical shell mounted at its larger end within the trough at the end of the casing, a cap spaced from the smaller end of the conical shell, a trough secured in the said cap, a shaft and bearing therefor within the conical shell, and blades fixed to the said shaft and adapted at their ends to extend into the said troughs.

4. A disinfecting apparatus comprising a casing, a trough secured interiorly to one end thereof, an open-ended conical shell secured at its larger end within the said trough in the casing, a cap secured to and spaced from the smaller end of the conical shell, a trough in the said cap, a bracket secured within the conical shell, a shaft and a bearing therefor mounted in said bracket, a blade secured at one end to the said shaft and at its opposite end extending into the trough in the said cap, a blade also secured at one end thereof to the said shaft and at its opposite end extending into the trough at the inner end of the conical shell, a cylindrical intermediate member secured at one end to the outer surface of the conical shell and terminating in a conical portion at its other end, a cap secured to and spaced from the conical end of the cylindrical intermediate member, and a trough in the last aforesaid cap.

Signed by me this 13th day of March, 1918.

HUGH PAUL CONLON.

Witnesses:

GEORGE B. DAWSON,  
PATRICIA CAMPBELL.