



(11) **EP 2 025 601 B1**

(12) **EUROPEAN PATENT SPECIFICATION**

(45) Date of publication and mention of the grant of the patent:
21.09.2011 Bulletin 2011/38

(51) Int Cl.:
B65B 57/04^(2006.01) B65B 61/06^(2006.01)
B65B 61/08^(2006.01)

(21) Application number: **08380216.5**

(22) Date of filing: **15.07.2008**

(54) **Machine for handling blister packs**

Maschine zur Handhabung von Blisterpackungen

Machine pour la manipulation d'emballages blister

(84) Designated Contracting States:
AT BE BG CH CY CZ DE DK EE ES FI FR GB GR HR HU IE IS IT LI LT LU LV MC MT NL NO PL PT RO SE SI SK TR

(30) Priority: **07.08.2007 ES 200702222**

(43) Date of publication of application:
18.02.2009 Bulletin 2009/08

(73) Proprietor: **Grifols, S.A.**
08022 Barcelona (ES)

(72) Inventors:
• **Sanchez Maulini, Manuel**
08970 Sant Joan Despi
(Barcelona) (ES)

• **Oriols Gaja, Joan**
08592 Sant Marti de Centellas
(Barcelona) (ES)

(74) Representative: **Durán Moya, Luis-Alfonso et al**
Durán-Corretjer
Còrsega, 329
08037 Barcelona (ES)

(56) References cited:
EP-A- 0 860 364 EP-A- 1 527 858
WO-A-2005/105574 FR-A- 2 810 974
GB-A- 2 295 820 US-A- 5 460 471

EP 2 025 601 B1

Note: Within nine months of the publication of the mention of the grant of the European patent in the European Patent Bulletin, any person may give notice to the European Patent Office of opposition to that patent, in accordance with the Implementing Regulations. Notice of opposition shall not be deemed to have been filed until the opposition fee has been paid. (Art. 99(1) European Patent Convention).

Description

[0001] The present invention relates to a machine for handling blister packs, particularly for its application in the hospital sector.

[0002] Blister packs are containers made of transparent plastics that contain a product in a blister allowing it to be displayed and at the same time protected from blows during handling and transport operations.

[0003] Blister packs are generally used for products of small size and on many occasions form a distribution unit in themselves. A metal or cardboard sheet serves to support the product and seal the blisters containing one or more product units.

[0004] The blister pack is a usual form of container for pharmaceutical products in the form of capsules, pills or tablets, for example, in which each blister of the blister pack contains a unit of medicine.

[0005] Hospital pharmacies therefore receive blister-packed medicines. However, in a hospital, medicines are to be dispensed in the correct dose to be taken by the patient. In pharmacies a "de-blistering" operation is therefore necessary which consists of removing from the blister pack, by breaking the sealing sheet, the units of medicine that are required so as to put it in an intermediate container (glass, bottle) in which the medicine or medicines to be administered are taken to the patient.

[0006] Machines that perform the de-blistering operation are known that were originally designed for the complete or partial reuse of medicines by pharmaceutical companies, and were adapted subsequently for use in pharmacies, such as hospital pharmacies.

[0007] A problem associated with de-blistering is that, although it is easy to perform using de-blistering machines of known type, during transfer to the patient in the hospital, the units of medicine may be damaged, lost or stolen.

[0008] US patent 6318051 discloses a device for automatically cutting pills packed in blister packs individually. The device comprises multiple blister pack storage stations in a circular arrangement. Consequently, it takes up a great deal of space. In addition, it is not a very versatile machine.

[0009] To solve the problems indicated, the present invention proposes a machine for cutting blister packs, which are transferred, once cut, to a delivery zone for possible packing or introduction into an intermediate container.

[0010] The present invention therefore provides a fast and convenient means of separating the required dose for a client from the blister pack, allowing the dose to be transferred to the client in secure conditions.

[0011] Accordingly, the present invention consists of a machine for handling blister packs that comprises a first blister pack storage station provided with an opening for feeding blister packs to a second blister pack transport station for transporting the blister packs to a third blister pack cutting station, and an opening for transferring the

cut blister packs to a delivery or packing station.

[0012] According to a particularly preferred embodiment, the cutting station has a blister pack cutter with rotating capacity. This characteristic means that the machine is capable of cutting blister packs with different blister configurations. In addition, it allows different types of blister pack to be stored in the same blister pack feed opening of the storage station.

[0013] In accordance with the investigations and tests carried out, the blister pack cutter is a cutter of the mechanical type, and even more preferably of the die cutting type.

[0014] The device has an element to control the rotation of the cutter, and a device for visually identifying the blister packs, said control element and said device being associated with each other through a control element.

[0015] This characteristic means that the device can process a wide range of forms and arrangements of blister packs with a single die.

[0016] The visual identification device may comprise video cameras situated in the feed zone and in the transport station.

[0017] In a preferred embodiment the visual identification device comprises two cameras. One camera, situated beneath the blister pack loader and focused upwards, performs the functions of searching for a pattern in the image to check that it is the correct product, checking the orientation of the blister pack and storing the photograph. Another camera, situated in a scanning zone and focused downwards, performs the functions of identifying the horizontal orientation of the blister pack, storing the photograph and detecting whether a pill is missing or, optionally, if the blister pack is faulty.

[0018] The element to control rotation of the cutter begins with a digitalised image and, using specially designed software, transforms this image into data which mark points X and Y and the turns required to create the cutting program.

[0019] In another preferred embodiment, the machine has a packing zone for the cut blister packs connected to the above-mentioned opening for transfer of the blister packs, which more preferably comprises a rejection opening, an opening for manual introduction and a packing zone. More preferably still, the packing zone will comprise a bagger.

[0020] The blister pack feed opening may be supplied from a feeder situated parallel to or above the opening.

[0021] For a better understanding of the invention, examples of embodiments of the present invention and the tests performed are appended as explanatory but not limiting examples.

Fig. 1 shows a general diagram of a possible embodiment of the machine according to the present invention.

Fig. 2 shows a control diagram applicable to a possible embodiment of a machine according to the present invention.

Fig. 3 shows a control - physical elements relationship diagram on which the user interface of a machine according to the present invention may be based.

Fig. 4 shows an embodiment of the blister pack loading zone of a possible embodiment of the machine according to the present invention.

Fig. 5 shows a diagram of the cutting device of an embodiment of the machine according to the present invention.

Figs. 6 and 7 are two diagrams that show the advantages of the possibility of rotating the cutter of the device according to the present invention.

Fig. 8 is a perspective view of the cutting zone of an embodiment of the machine according to the present invention.

Fig. 9 is a detail in perspective of the view shown in Fig. 8.

Fig. 10 is a view in side elevation of the cutting zone shown in Figs. 8 and 9.

Fig. 11 is a view from below of the cutting zone shown in Figs. 8 to 10.

Fig. 1 illustrates a zone or station diagram of a possible embodiment of the blister pack cutting machine -100- according to the present invention.

[0022] The machine shown comprises a first blister pack storage station -1000-, comprised of a feeding zone which comprises a blister pack storage unit -1- from which the blister packs fall by gravity to a conveyor belt -2-, through a blister pack feed opening.

[0023] In a possible alternative embodiment, the blister packs are removed by a pincer associated with the blister pack transport system, without the need to fall by gravity. The blister pack transport station, in this case a transfer station -2000- (for example a conveyor belt -2- or a Cartesian table with associated pincer -21-) takes the unloaded blister packs -100- from the blister pack feed station -1000- to a third station -3000- for cutting the blister packs -100-.

[0024] The blister pack cutting station -3000- has a cutter -3- which, in the case shown has a punch -31- that cuts the blister packs, which fall through an opening -41- to a fourth station -4000- for delivering or packing the blister packs, depending on the specific requirements of the application.

[0025] In the embodiment shown as a diagram in Fig. 1, the fourth station -4000- is a blister pack packing zone -4- which has a waste outlet -42- and a packing outlet -43- which may give access, for example, to a bagger of known type, and an opening -44- for the manual introduction of medicines. Similarly, the fourth station -4000- comprises sensors -45-, -46- to control the passage of the medicines. These sensors may be optical (cameras), presence detectors or of another type.

[0026] Selection control for passage to the waste opening -42- or the packing or bagging opening -43- may be carried out by any suitable method, for example by

traps.

[0027] For better control of the cutting operation, in a preferred embodiment, the machine according to the present invention comprises a visual identification device. Said device may comprise video cameras -51-, -52- situated in the feed opening and in the transport station -2000-. The camera -52- situated in the feed zone may be used to control the position of the blister pack, to check that the product dispensed is the correct one, and to take a view of the reverse of the blister pack. The camera -51- in the transfer station -2000- may be used to control the orientation of the blister pack, carry out product recognition by means of a control device that comprises an image processor, search for a reference point for movements of the cutter (relative zero), and take a photograph of the obverse, if necessary, (for example, if said face has useful information that can be extracted).

[0028] The transfer station -2000- may take the form of a rolling band, or an x-y table, which allows the blister pack to move in direction x-y during the cutting process.

[0029] The x-y table may comprise, for example, a linear guide system, provided with an alternating current motor, with the corresponding actuators and the corresponding end-of-run detection sensors.

[0030] Preferably, the speed of movement of the blister pack is approximately 150 mm per second, and the system positioning precision is preferably equal to or less than 0.05 mm.

[0031] To avoid movement during the cutting phase, the blister pack may be held by a pincer -21- illustrated in Figs. 6 and 7. Said pincer may act on the blister pack -100- either from the feed zone or subsequently.

[0032] Fig. 2 shows a control device diagram for the machine in Fig. 1. In the diagram, control device -5000- can be seen, which in turn has an image processing module -2001- which processes the images from the cameras -51-, -52-, motor control devices -1001-, a special module -3001- for synchronising the motor control devices in the cutting process, and safety devices -5001-. The control -5000- also has a module -4001- for synchronisation with the cut blister pack packer, and connections to a communications device -6001-, a user interface -6002- (for example, keyboard, screen, etc.), an electronic memory device -6003- provided with the necessary databases for the automatic operation of the machine, and a communications port -6005- with a printer. Likewise, in a preferred embodiment, the control device -5000- may be connected to a bar code reader -6004- for product recognition.

[0033] In Fig. 3, the control arrangement for the embodiment illustrated is shown in greater detail, and the relationship of this control arrangement with the user interface -6002-.

[0034] The control -6000- has a programming motor -6022- which controls the digital I/O cards -6001'-, and the communications ports -6001- of the control device (USB, Ethernet, parallel, serial). The card digitaliser -2002- is controlled through a special module -6023-

which processes the images from the cameras -51-, -52-. The motors -1001- are controlled by means of another special module -6024- through the corresponding controllers -1003- and amplifier cards -1002-.

[0035] Fig. 4 shows a perspective view of the feed zone -1000- of the blister packs -100- from a storage device (not illustrated) to an x-y transport table. In this case, the blister pack -100- falls by gravity, guided by guides -11-. If necessary, it is possible to place another similar feeder -11- next to the one illustrated.

[0036] There are various possibilities with regard to the blister pack cutting system: laser cutting, cutting by fluid (for example, water under pressure) or mechanical cutting.

[0037] Cutting using pressurised fluid does not appear the most suited to a hospital environment, in that simplicity of the machine must take precedence.

[0038] As to laser cutting, since the blister packs are formed in general by a double layer of plastics material (generally PVC) and another of aluminium, the PVC would be "burned" by the laser, an aspect not suited to the hospital environment.

[0039] Accordingly, the cutting system will preferably be mechanical.

[0040] Among mechanical cutting systems and to avoid the formation of residues in a mechanical cutting process of the machining type, the use of punch or die cutting systems is preferable, in other words those producing the cut by a sharp blow between the cutting element and the object to be cut.

[0041] Fig. 5 shows a diagram of a device for cutting -3- by means of a die. A motor -32- can be seen in Fig. 5 which provides a rotating movement that is transformed by means of a connecting rod device -33- into a reciprocal linear movement of a punch part -31- which has a cutter -34- at one end, opposite a counter part -35- supporting the blister pack, which gives access to the above-mentioned fourth station -4000-.

[0042] In a particularly preferred embodiment the cutter -34- (or the punch -31- and cutter -34- parts unit) have rotation capacity. This, among other advantages, allows a single die or punch to be used, as can be seen in Figs. 6 and 7.

[0043] Blister packs -100- can be seen therein, in which the products are placed in the blister pack in different positions (aligned in Fig. 7; in a quincunx in Fig. 6) and are cut by the same punch -34-, in a different rotation position in relation to the fixed portion -36- of the cutting zone. Thus, the same punch -34- can cut the individual doses from the blister pack for blister packs with different arrangements.

[0044] According to the studies carried out by the applicant, to allow a greater number of different blister packs to be cut without the need to change the punch, said punch has a rounded portion with a radius of approximately 6 mm.

[0045] The punch -34- may be rotated by means of a special motor -37- and a belt system -38-, situated be-

neath the actuating plane of the punch, as can be seen in Figs. 8 to 11.

[0046] Although the invention has been described with regard to an example of a preferred embodiment, these should not be considered as limiting the invention, which will be defined by the widest interpretation of the following claims.

10 Claims

1. Machine for handling blister packs, **characterised in that** it comprises a first blister pack storage station (1000) provided with an opening for feeding blister packs to a second blister pack transport station (2000) for transporting the blister packs to a third blister pack cutting station (3000), which comprises a blister pack cutter (3), an opening (41) for transferring the cut blister packs to a delivery or packing station (4000) and has a control element for the blister pack cutter, and a device (51,52) for visually identifying the blister packs in the storage station and the transport station, said control element and said device being associated with each other through another control element.
2. Machine, according to claim 1, **characterised in that** the blister pack cutter (3) has rotation capacity.
3. Machine, according to claim 1 or claim 2, **characterised in that** the blister pack cutter (3) is a mechanical-type cutter.
4. Machine, according to claim 3, **characterised in that** the blister pack cutter is a die-type cutter.
5. Machine, according to any one of claims 2 to 4, **characterised in that** the rotation control of the blister pack cutter (3) is produced depending on the typology of the blister pack detected by the visual identification device.
6. Machine, according to any one of claims 1 to 5, **characterised in that** it has a blister pack packing station (4000) connected to said opening for transferring the blister packs.
7. Machine, according to claim 6, **characterised in that** the blister pack packing station (4000) comprises a rejection opening and a manual introduction opening for packing.
8. Machine, according to claim 6 or claim 7, **characterised in that** the blister pack packing station (4000) comprises a bagger.
9. Machine, according to any one of claims 6 to 8, **characterised in that** the device for visual identification

comprises video cameras situated in the feed opening zone and in the transport station.

10. Machine, according to any one of claims 6 to 9, **characterised in that** the device for visual identification comprises two cameras, one situated beneath the blister pack loader and focused upwards, which performs the functions of searching for a pattern in the image to check that it is the correct product, checking the orientation of the blister pack and storing the photograph, and another camera situated in a scanning zone and focused downwards, performs the functions of identifying the horizontal orientation of the blister pack, storing the photograph and detecting whether a pill is missing or, optionally, if the blister pack is faulty.
11. Machine, according to any one of the preceding claims, **characterised in that** all said stations are in a linear arrangement.

Patentansprüche

1. Maschine zur Handhabung von Blisterpackungen, **dadurch gekennzeichnet, dass** sie eine erste Blisterpackungs-Speicherstation (1000) umfasst, welche ausgestattet ist mit einer Öffnung zum Zuführen von Blisterpackungen zu einer zweiten Blisterpackungs-Transportstation (2000) zum Transportieren der Blisterpackungen zu einer dritten Blisterpackungs-Schneidestation (3000), welche einen Blisterpackungs-Schneider (3), eine Öffnung (41) zum Weiterleiten der geschnittenen Blisterpackungen zu einer Liefer- oder Packstation (4000) umfasst, und welche ein Steuerelement für den Blisterpackungs-Schneider aufweist, und eine Vorrichtung (51, 52) zum visuellen Identifizieren der Blisterpackungen in der Speicherstation und der Transportstation, wobei das Steuerelement und die Vorrichtung durch ein weiteres Steuerelement miteinander assoziiert sind.
2. Maschine nach Anspruch 1, **dadurch gekennzeichnet, dass** der Blisterpackungs-Schneider (3) eine Rotationsfähigkeit aufweist.
3. Maschine nach Anspruch 1 oder Anspruch 2, **dadurch gekennzeichnet, dass** der Blisterpackungs-Schneider (3) ein Schneider mechanischen Typs ist.
4. Maschine nach Anspruch 3, **dadurch gekennzeichnet, dass** der Blisterpackungs-Schneider ein Stanztyp-Schneider ist.
5. Maschine nach einem der Ansprüche 2 bis 4, **dadurch gekennzeichnet, dass** die Rotationssteuerung des Blisterpackungs-Schneiders (3) abhängig von der von der visuellen Identifikationsvorrichtung

detektierten Typologie der Blisterpackung erzeugt wird.

6. Maschine nach einem der Ansprüche 1 bis 5, **dadurch gekennzeichnet, dass** sie eine Blisterpackungs-Packstation (4000) aufweist, welche mit der Öffnung zum Weiterleiten der Blisterpackungen verbunden ist.
7. Maschine nach Anspruch 6, **dadurch gekennzeichnet, dass** die Blisterpackungs-Packstation (4000) eine Ausschussöffnung und eine manuelle Einführöffnung zum Verpacken umfasst.
8. Maschine nach Anspruch 6 oder Anspruch 7, **dadurch gekennzeichnet, dass** die Blisterpackungs-Packstation (4000) einen Einpacker umfasst.
9. Maschine nach einem der Ansprüche 6 bis 8, **dadurch gekennzeichnet, dass** die Vorrichtung zur visuellen Identifikation Videokameras umfasst, welche sich in der Zuführöffnungszone und in der Transportstation befinden.
10. Maschine nach einem der Ansprüche 6 bis 9, **dadurch gekennzeichnet, dass** die Vorrichtung zur visuellen Identifikation zwei Kameras umfasst, wobei sich eine unterhalb des Blisterpackungs-Laders befindet und nach oben fokussiert, welche die Funktionen des Suchens nach einem Muster in dem Bild zum Prüfen, dass es das korrekte Produkt ist, Prüfers der Orientierung der Blisterpackung und Speicherns des Fotos durchführt, und eine weitere Kamera, welche sich in einer Abtastzone befindet und nach unten fokussiert, die Funktionen des Identifizierens der horizontalen Orientierung der Blisterpackung, Speicherns des Fotos und Detektierens, ob eine Tablette fehlt oder, optional, ob die Blisterpackung fehlerhaft ist, durchführt.
11. Maschine nach einem der vorhergehenden Ansprüche, **dadurch gekennzeichnet, dass** alle Stationen in einer linearen Anordnung sind.

Revendications

1. Machine de manipulation d'emballages blister, **caractérisée par le fait qu'**elle comprend un premier poste (1000) assigné au stockage d'emballages blister et muni d'une ouverture conçue pour alimenter, en emballages blister, un deuxième poste (2000) de convoyage d'emballages blister, dévolu au convoyage desdits emballages blister vers un troisième poste (3000) de sectionnement d'emballages blister, lequel est pourvu d'un sectionneur (3) d'emballages blister et d'une ouverture (41) affectée au transfert des emballages blister sectionnés à un poste (4000)

- de délivrance ou de conditionnement, et présente un élément de commande dédié audit sectionneur d'emballages blister, et un dispositif (51, 52) d'identification visuelle des emballages blister dans le poste de stockage et le poste de convoyage, ledit élément de commande et ledit dispositif étant mutuellement associés par l'intermédiaire d'un autre élément de commande. 5
2. Machine selon la revendication 1, **caractérisée par le fait que** le sectionneur (3) d'emballages blister est doué d'aptitude rotatoire. 10
3. Machine selon la revendication 1 ou la revendication 2, **caractérisée par le fait que** le sectionneur (3) d'emballages blister est un sectionneur de type mécanique. 15
4. Machine selon la revendication 3, **caractérisée par le fait que** le sectionneur d'emballages blister est un sectionneur du type emporte-pièce. 20
5. Machine selon l'une quelconque des revendications 2 à 4, **caractérisée par le fait que** la commande de la rotation du sectionneur (3) d'emballages blister est exécutée en fonction de la typologie de l'emballage blister détecté par le dispositif d'identification visuelle. 25
6. Machine selon l'une quelconque des revendications 1 à 5, **caractérisée par le fait qu'elle** comporte un poste (4000) de conditionnement d'emballages blister, relié à ladite ouverture affectée au transfert des emballages blister. 30
7. Machine selon la revendication 6, **caractérisée par le fait que** le poste (4000) de conditionnement d'emballages blister comprend une ouverture de rejet et une ouverture d'introduction manuelle, en vue du conditionnement. 35 40
8. Machine selon la revendication 6 ou la revendication 7, **caractérisée par le fait que** le poste (4000) de conditionnement d'emballages blister comprend une ensacheuse. 45
9. Machine selon l'une quelconque des revendications 6 à 8, **caractérisée par le fait que** le dispositif d'identification visuelle comprend des caméras vidéo placées dans la zone de l'ouverture d'alimentation, et dans le poste de convoyage. 50
10. Machine selon l'une quelconque des revendications 6 à 9, **caractérisée par le fait que** le dispositif d'identification visuelle compte deux caméras dont l'une, placée au-dessous du chargeur d'emballages blister et pointant vers le haut, remplit les fonctions de recherche d'un motif dans l'image, afin de vérifier qu'il s'agit du produit correct, de vérification de l'orientation de l'emballage blister et de stockage de la photographie ; et une autre caméra, placée dans une zone de balayage exploratoire et pointant vers le bas, remplit les fonctions d'identification de l'orientation horizontale dudit emballage blister, de stockage de la photographie et de détection visant à établir si une pilule est manquante ou, le cas échéant, si ledit emballage blister est défectueux. 55
11. Machine selon l'une quelconque des revendications précédentes, **caractérisée par le fait que** lesdits postes sont tous agencés en une disposition linéaire.

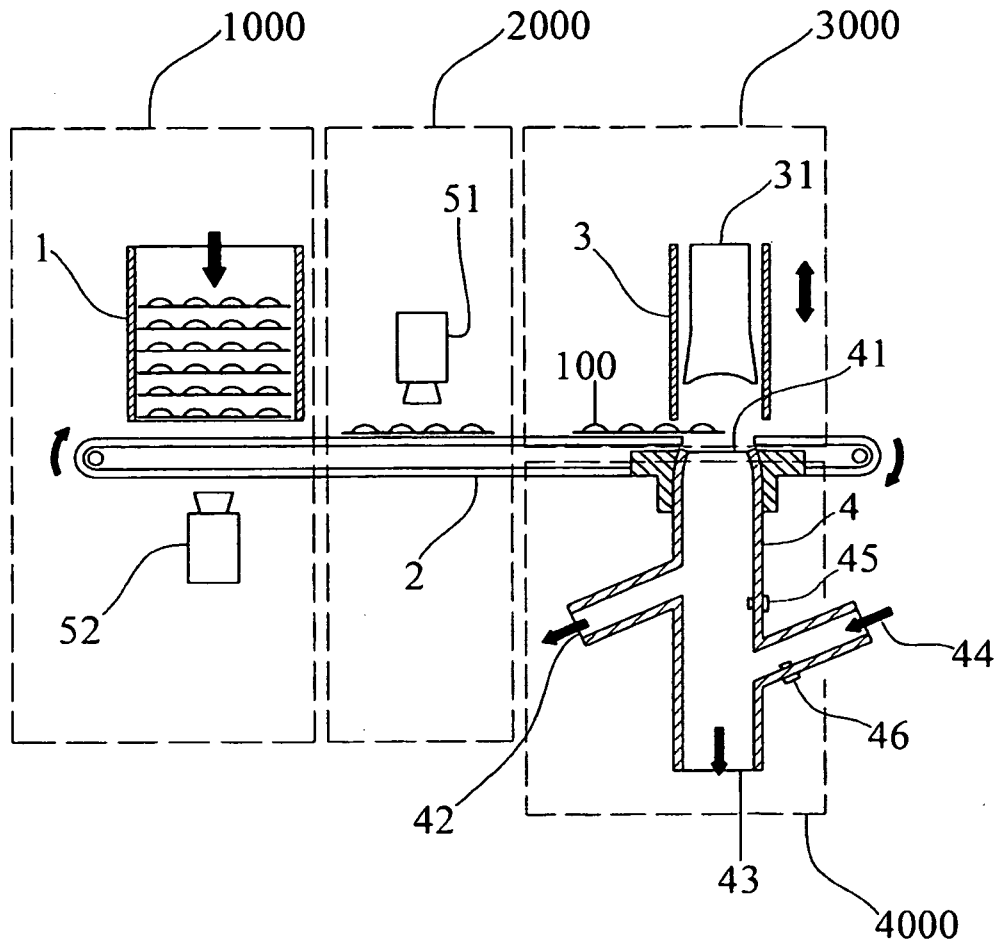

FIG.1

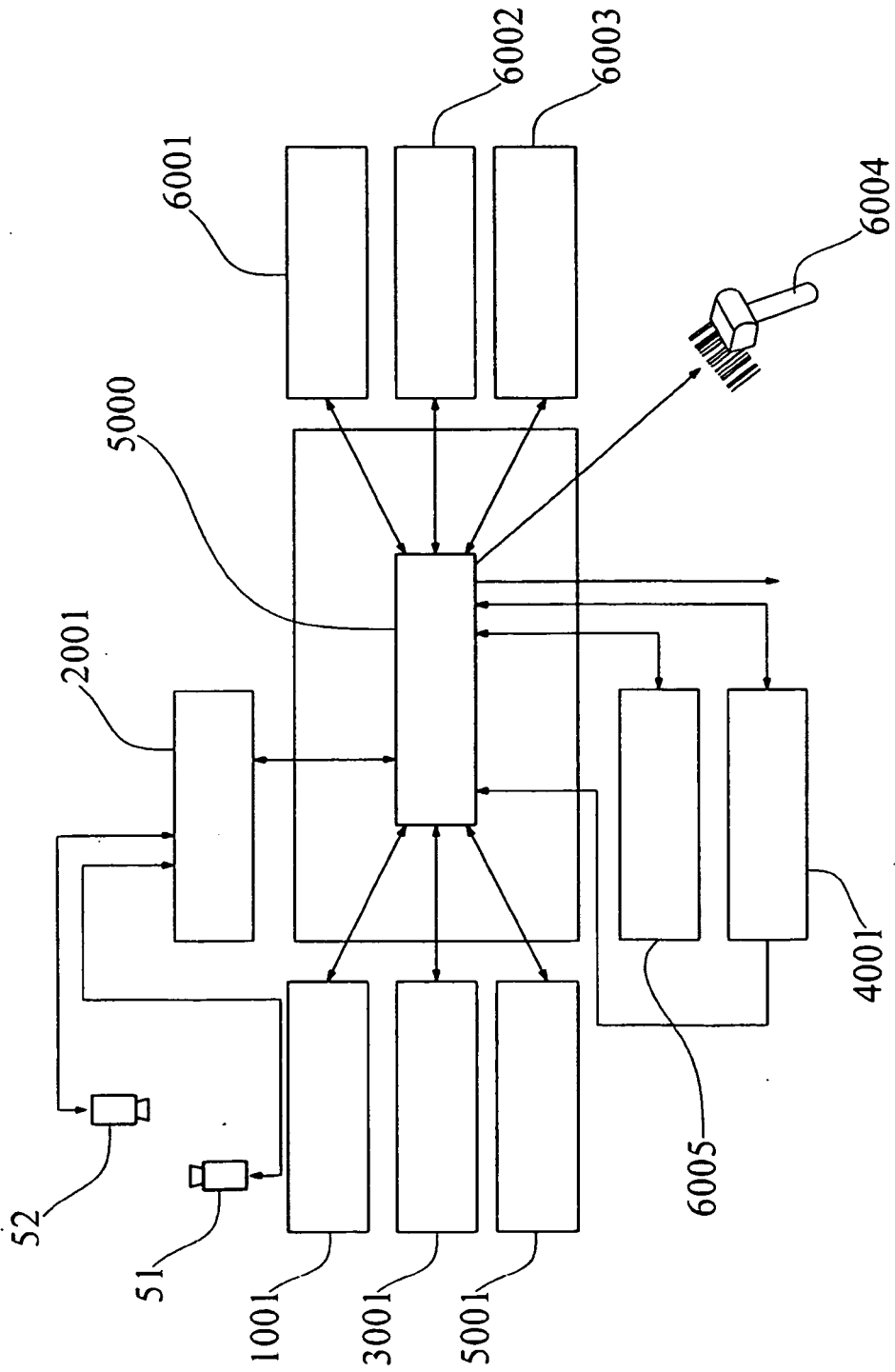

FIG.2

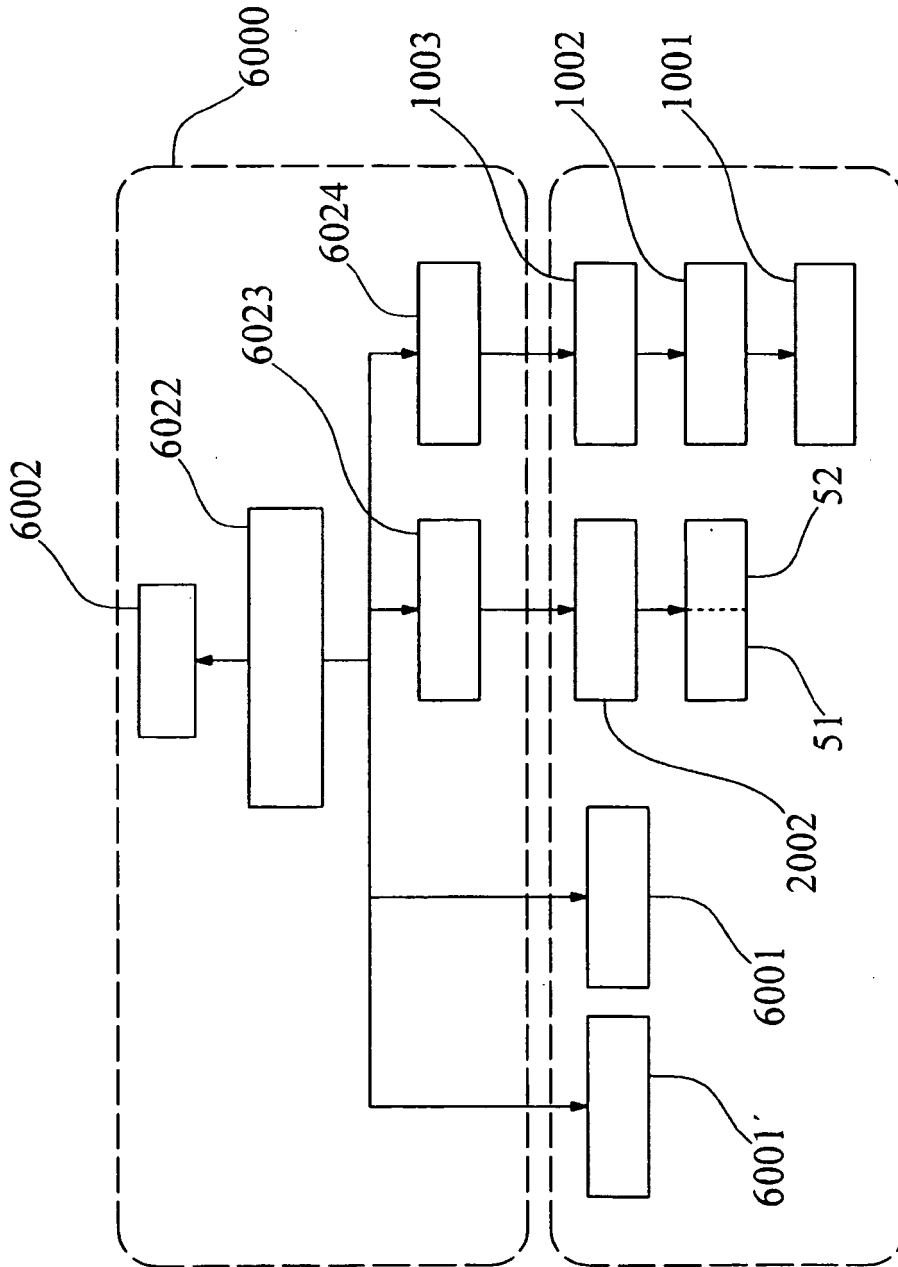

FIG.3

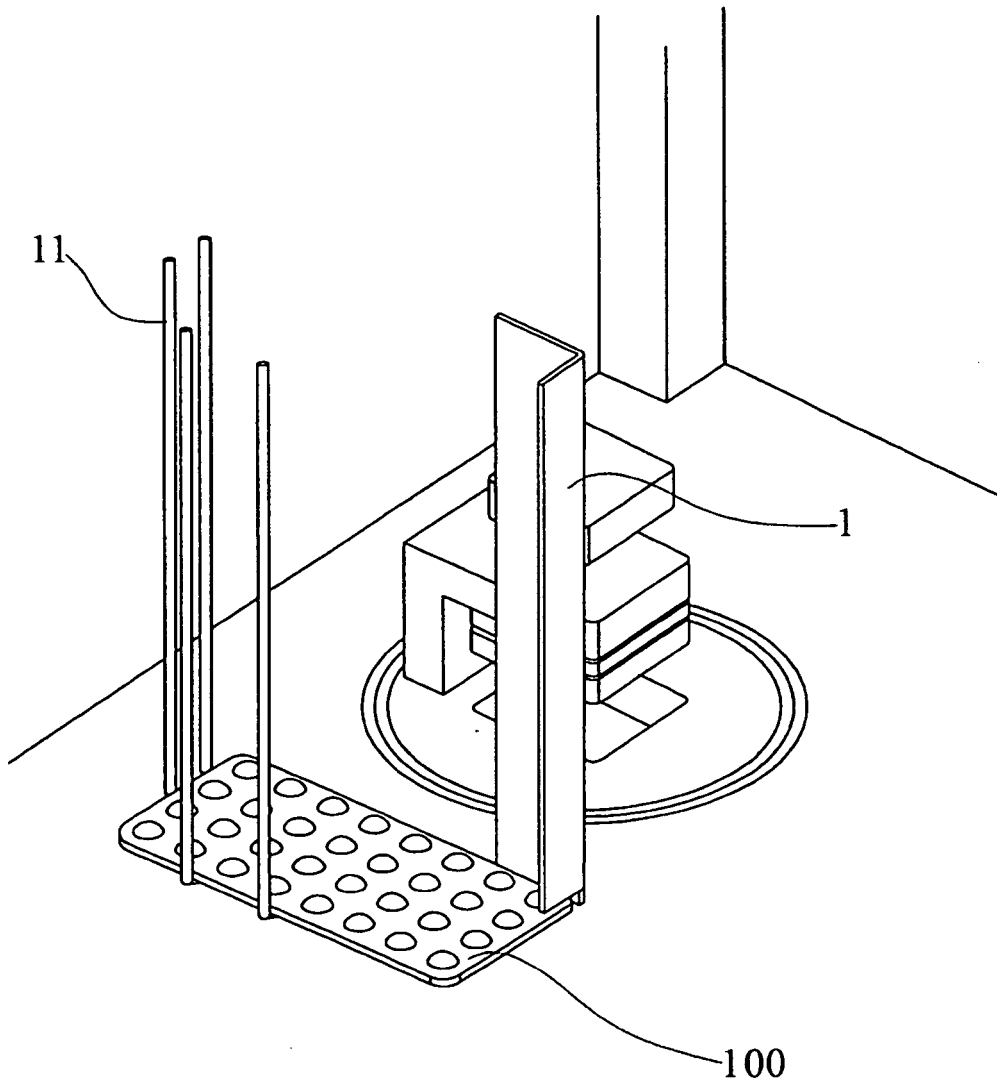

FIG. 4

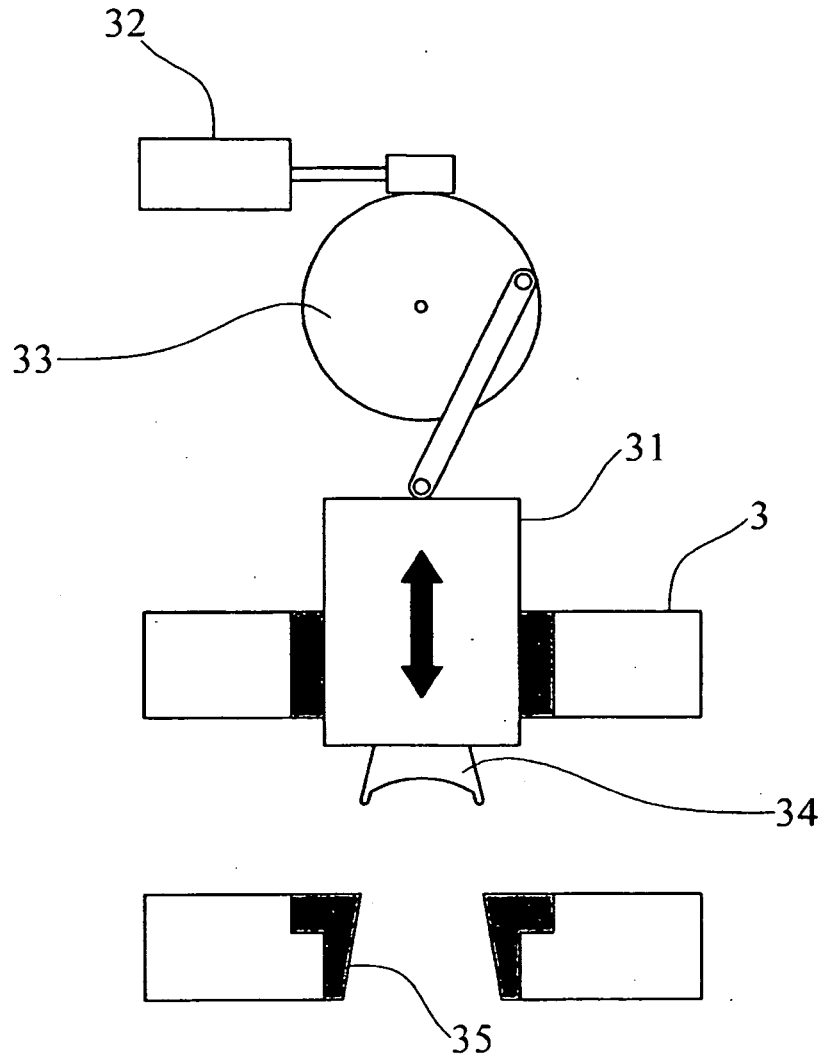

FIG.5

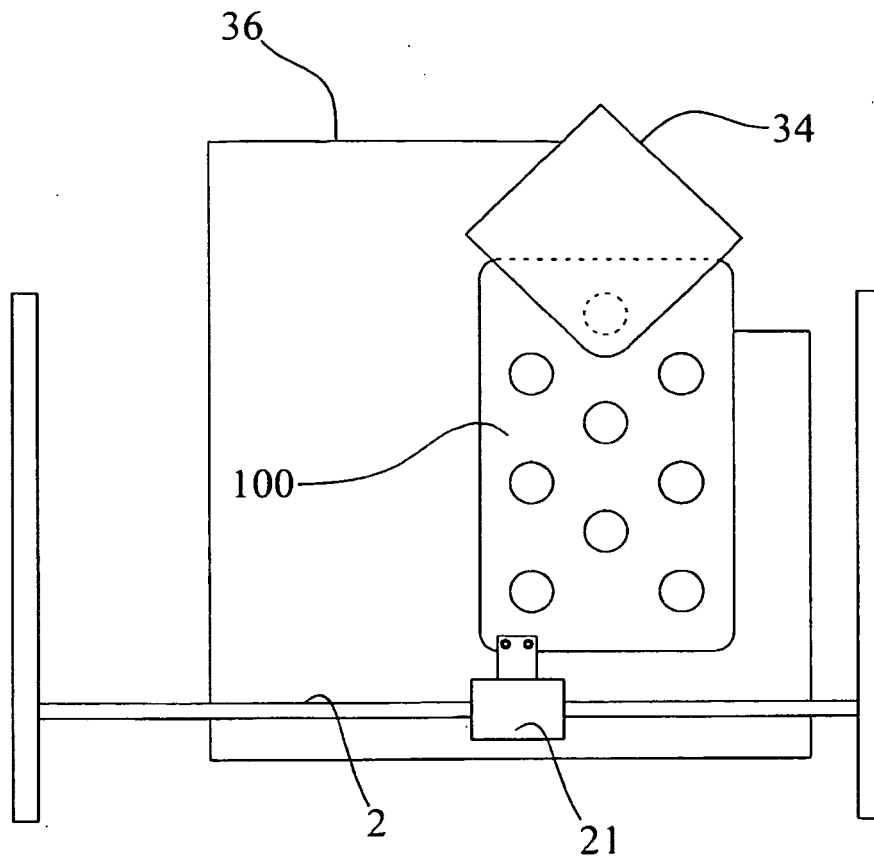

FIG.6

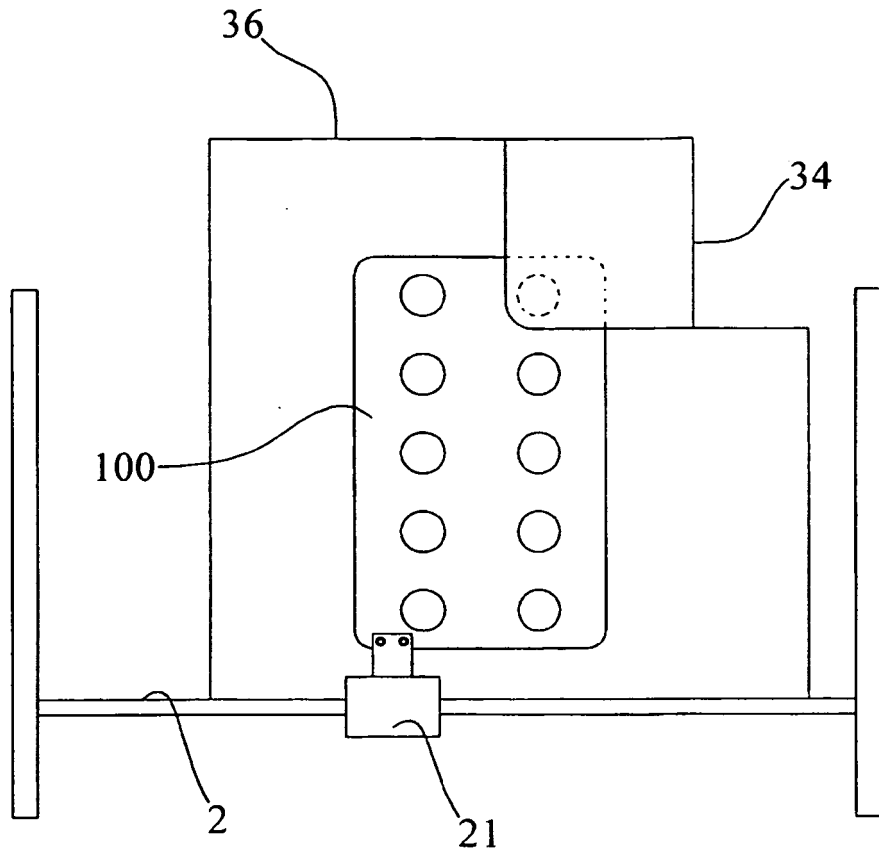

FIG. 7

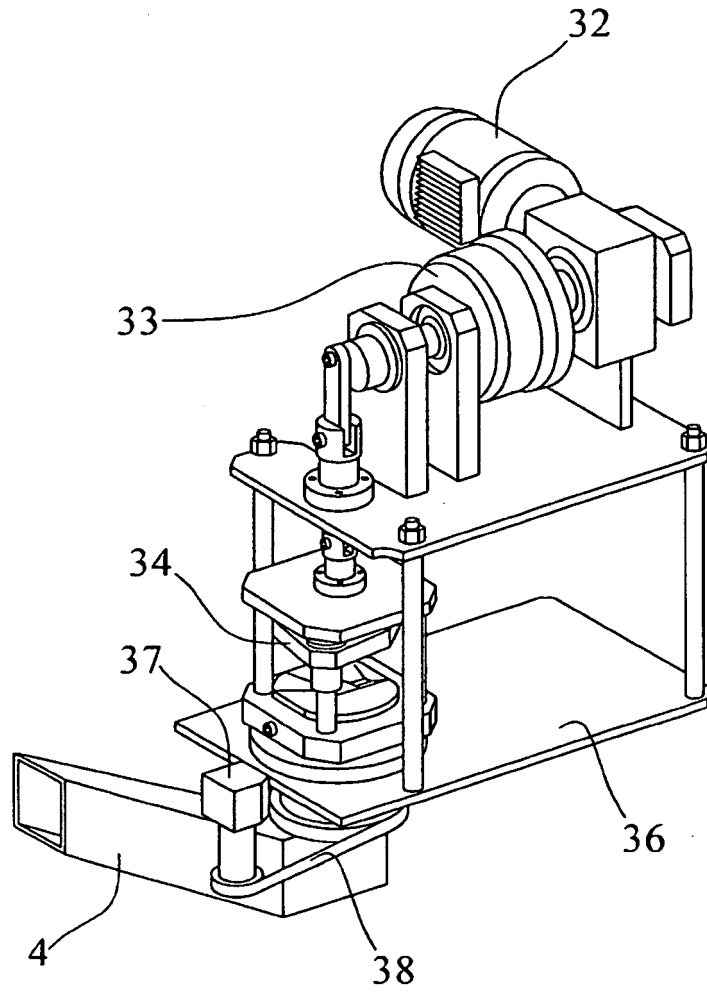

FIG. 8

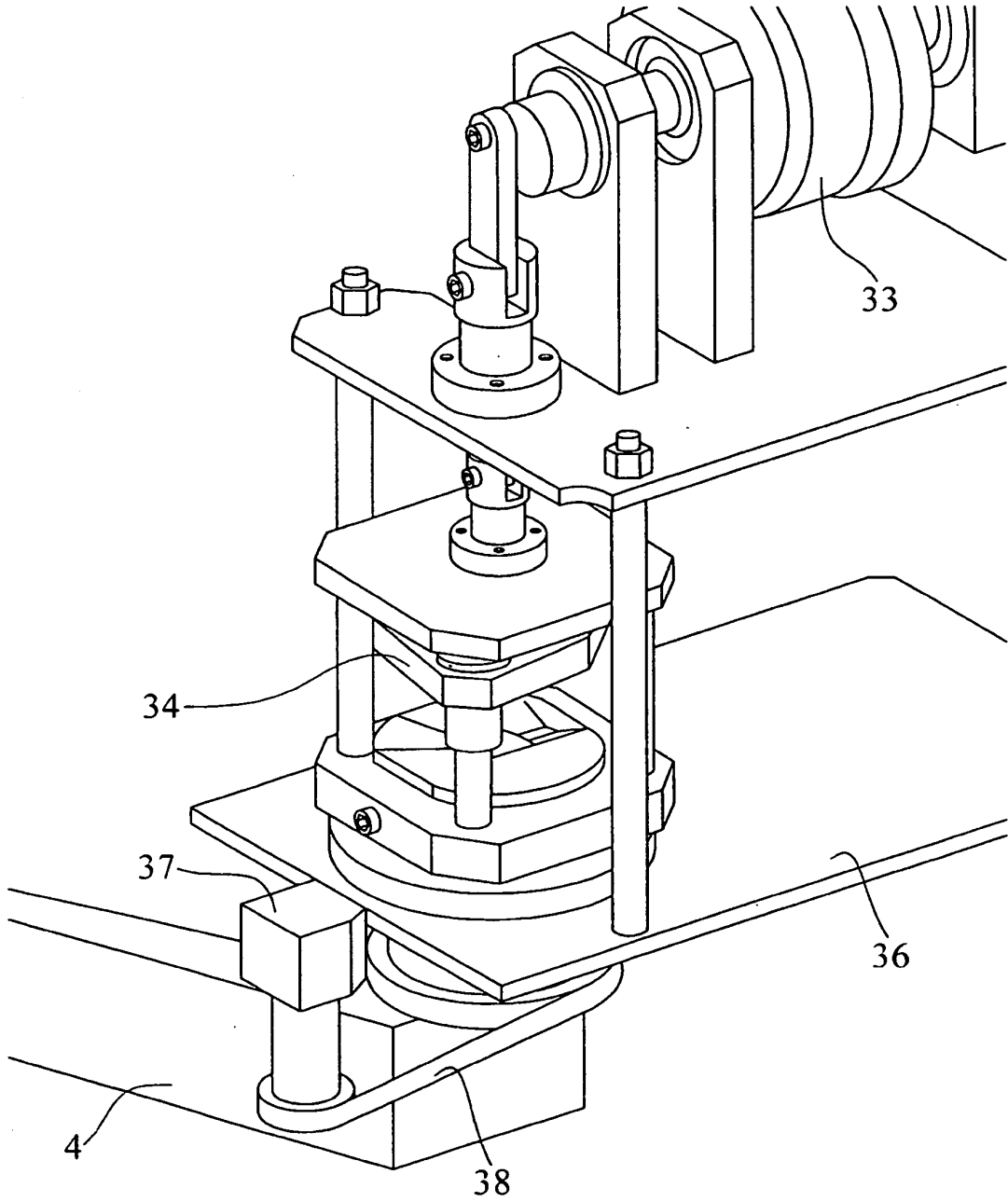

FIG. 9

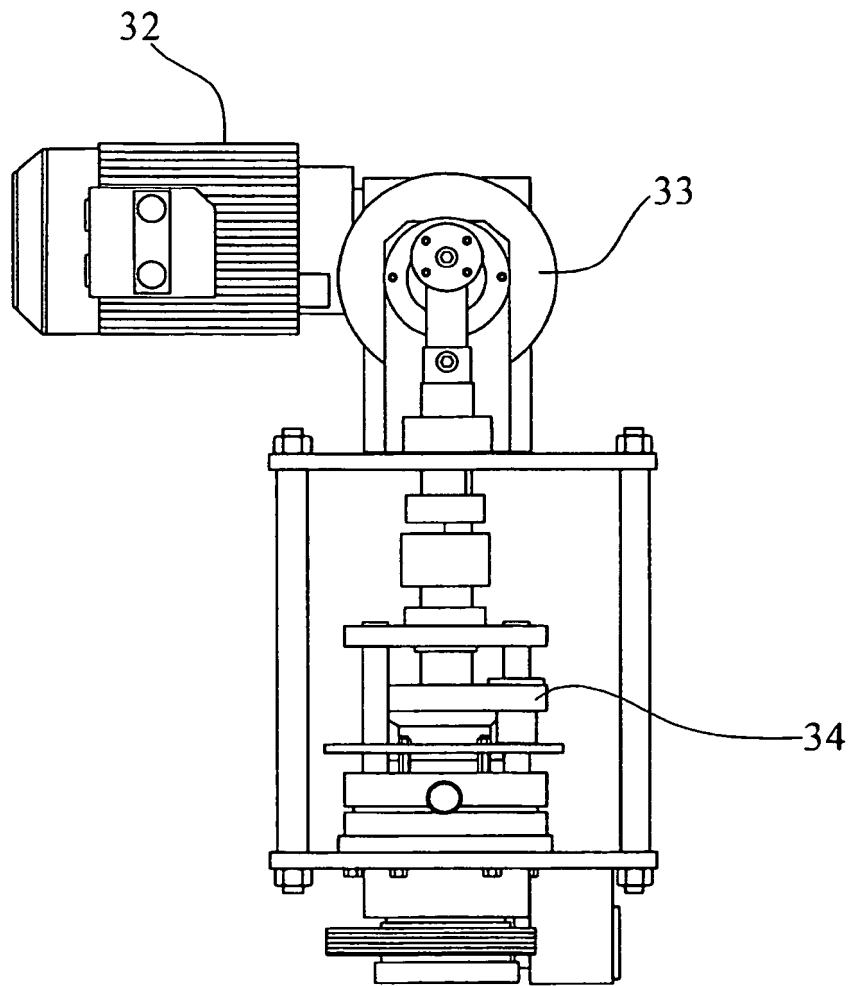

FIG. 10

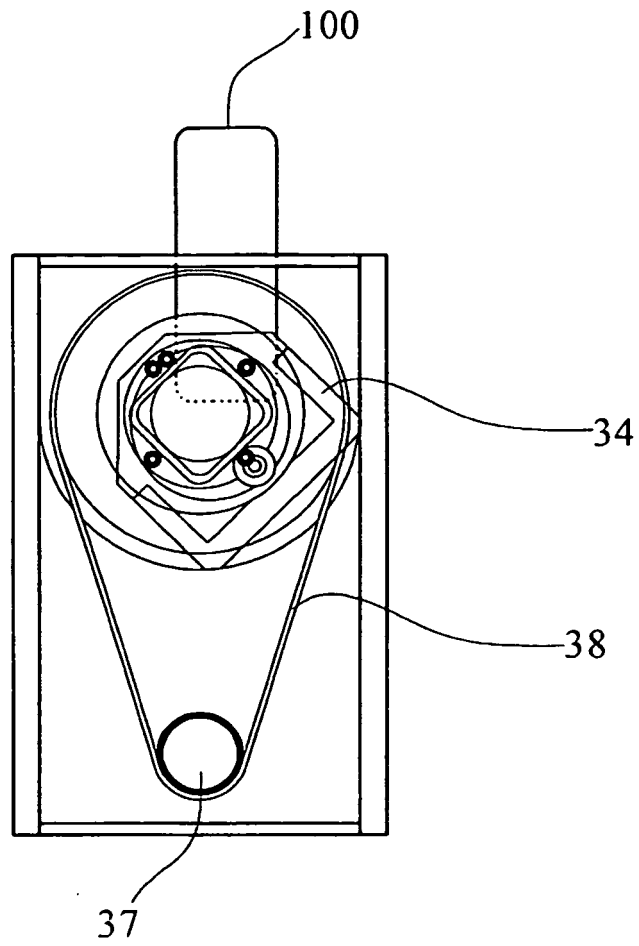

FIG. 11

REFERENCES CITED IN THE DESCRIPTION

This list of references cited by the applicant is for the reader's convenience only. It does not form part of the European patent document. Even though great care has been taken in compiling the references, errors or omissions cannot be excluded and the EPO disclaims all liability in this regard.

Patent documents cited in the description

- US 6318051 B [0008]