

(19)



(11)

EP 1 909 237 A2

(12)

EUROPEAN PATENT APPLICATION

(43) Date of publication:

09.04.2008 Bulletin 2008/15

(51) Int Cl.:

G07D 1/02^(2006.01)

G07D 9/06^(2006.01)

(21) Application number: **07117432.0**

(22) Date of filing: **27.09.2007**

(84) Designated Contracting States:

AT BE BG CH CY CZ DE DK EE ES FI FR GB GR HU IE IS IT LI LT LU LV MC MT NL PL PT RO SE SI SK TR

Designated Extension States:

AL BA HR MK RS

• **Imai, Mikito**

Hyogo-ken Hyogo (JP)

• **Nishida, Koichi**

Hyogo-ken Hyogo (JP)

• **Tone, Hiroshi**

Hyogo-ken Hyogo (JP)

(30) Priority: **28.09.2006 JP 2006264467**

(74) Representative: **Jenkins, Peter David**

Page White & Farrer

Bedford House

John Street

London, WC1N 2BF (GB)

(71) Applicant: **Glory Ltd.**

Hyogo-Ken (JP)

(72) Inventors:

• **Uehara, Osamu**

Hyogo-ken Hyogo (JP)

(54) **Coin-roll Storing Machine**

(57) The present invention provides a coin-roll storing machine which can reduce the dimension in the width direction and facilitate to ensure the installation space, as compared with those of a type including a plurality of coin-roll storing portions each adapted to put the coin-roll on the bottom face such that the axis of each coin-roll package extends in the horizontal width direction. In

one aspect, a coin-roll storing machine 1 includes a storing main body 1a, and three coin-roll drawers 11, 12, 13, respectively provided such that they can be drawn out relative to the storing main body 1a. In the respective coin-roll drawers 11, 12, 13, a plurality of coin-roll storing portions 14 are provided, each for storing coin-roll B, with each axis of the coin-roll B being oriented in the vertical direction.

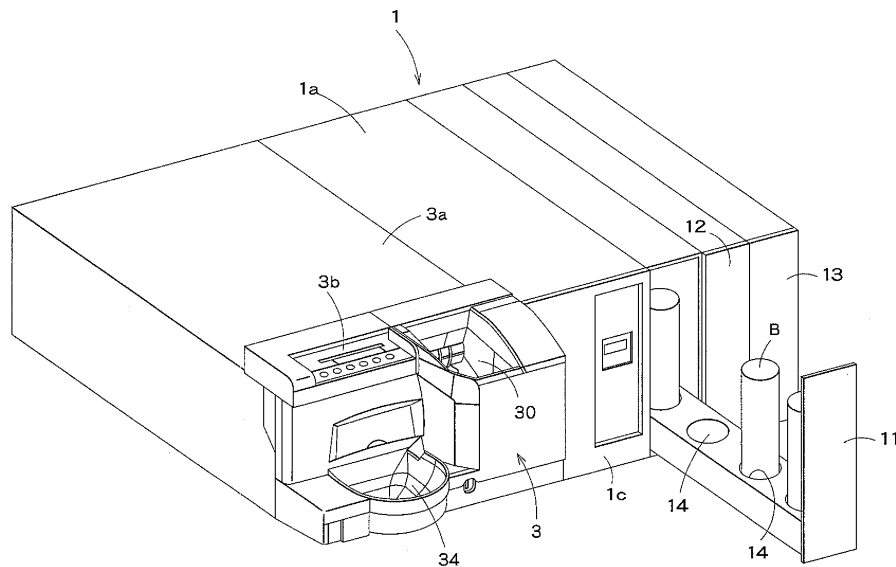

FIG. 2

EP 1 909 237 A2

Description

BACKGROUND OF THE INVENTION

Field of the Invention

[0001] The present invention relates to coin-roll (a roll of coins) storing machine for storing coin-roll (bar-shaped predetermined number of stacked coins, e.g. each roll made by wrapping the same kind of coins into a package), in respectively particular coin-roll storing portions in order to separate the kinds of coins, and in particular to a coin-roll storing machine adapted to store coin-roll therein, with the coin-roll independently standing up in the vertical direction.

Background Art

[0002] For instance, as the coin-roll storing machine for storing coin-roll in respectively particular coin-roll storing portions to separate the kinds of coins, those described in JP11-250314A and JP2006-85332A are known. The coin-roll storing machines respectively disclosed in the above JP11-250314A and JP2006-85332A include multiple stages of coin-roll drawers each able to be independently drawn out, in the forward direction, by hand, from a housing (storing main body) of the coin-roll storing machine. Each coin-roll drawer includes a plurality of coin-roll storing portions, each for storing coin-roll, usually consisting of fifty (50) coins, while putting them on the bottom face of the drawer horizontally in the width (lateral) direction, or such that the axis of each coin-roll extends in the horizontal width direction.

[0003] However, there are problems as described below, in the aforementioned conventional coin-roll storing machine. For example, each coin-roll storing portion of the conventional coin-roll storing machine is configured to store the coin-roll therein such that the axis of each coin-roll extends in the horizontal width direction. Thus, the dimension in the width direction of the storing main body should be larger. Additionally, in the case where the coin-roll storing machine is provided in combination with a coin change machine to be arranged in the lateral direction, i.e., in the case where the coin-roll storing machine is installed in a juxtaposition to the coin change machine, the dimension in the width direction of the entire body of a resultant change supplement and management system, which is a combined body of the coin-roll storing machine and the coin change machine, should be larger. Thus, it may be difficult to ensure an installation space for such a change supplement and control system.

[0004] This invention was made in light of the point above, and therefore it is an object thereof to provide a coin-roll storing machine which can reduce the dimension in the width direction and facilitate to ensure the installation space, as compared with those including a plurality of coin-roll storing portions each adapted to put the coin-roll on its bottom face such that the axis of each coin-roll

package extends in the horizontal width direction.

[0005] Another object of the present invention is to provide a coin-roll storing machine which can provide the same benefit as described above, as well as can judge each kind of the coin-roll stored in the plurality of coin-roll storing portions in the respective coin-roll drawers, in a shorter time, thereby to facilitate management of the total amount of money of the coin-roll.

10 SUMMARY OF THE INVENTION

[0006] The present invention is a coin-roll storing machine, comprising: a storing main body; a coin-roll drawer which is provided such that it can be drawn out relative to the storing main body, and having a plurality of coin-roll storing portions, each for storing coin-roll with each axis of coin-roll being oriented in the vertical direction.

[0007] According to the coin-roll storing machine, the coin-roll can be stored with the axis of the coin-roll being oriented in the vertical direction relative to each coin-roll storing portion, as such the dimension in the width direction of the storing main body can be significantly reduced, as compared with the type of storing the coin-roll while putting them on each coin-roll storing portion such that the axis of each coin-roll extends in the horizontal direction relative to the coin-roll storing portion. This can further facilitate to ensure the installation space of the coin-roll storing machine. Moreover, in the case where the coin-roll storing machine is installed in a juxtaposition to a coin change machine, the dimension in the width direction of a change supplement and management system, i.e., the resultant combined body from the two machines, can be further reduced.

[0008] In the coin-roll storing machine according to this invention, it is preferred that the coin-roll drawer is configured such that it can be drawn out, by hand, in the horizontally longitudinal direction, between its closed position and its drawn-out position, relative to the storing main body. In this way, an operator can perform drawing out and pushing in operations of the coin-roll, more readily, relative to the coin-roll storing machine.

[0009] In the coin-roll storing machine as described above, it is preferred that the coin-roll storing machine further comprises: a displacement detection means for detecting the displacement in the longitudinal direction of the coin-roll drawer relative to the storing main body; a coin-roll diameter sensor including a light emitting unit and a light receiving unit respectively fixed to the coin-roll storing main body in positions opposed to each other across an area through which the coin-roll stored in the coin-roll drawer will pass during drawing out and pushing in the coin-roll drawer, the coin-roll diameter sensor being adapted to output a signal corresponding to presence or absence of shading due to the coin-roll; and a judgment means for judging the number and the kind of money of the coin-roll stored in each coin-roll storing portion of the coin-roll drawer, based on the displacement in the longitudinal direction of the coin-roll drawer to be detected by

the displacement detection means as well as on the output of the coin-roll diameter sensor.

[0010] According to the coin-roll storing machine described above, the judgment means can judge the presence or absence and the kind of money of the coin-roll stored in each coin-roll storing portion of the coin-roll drawer, based on the displacement in the longitudinal direction of the coin-roll drawer to be detected by the displacement detection means as well as on the output of the coin-roll diameter sensor, when drawing out/ pushing in the coin-roll drawer, by hand, relative to the storing main body. In this case, the kind of money of the coin-roll can be judged, on the basis of the diameter of the coin-roll, which is to be identified based on the displacement in the longitudinal direction of the coin-roll drawer as well as on the output of the coin-roll diameter sensor. Thus, by utilizing the longitudinal displacement of each coin-roll drawer, even though there is some change of speed when drawing out/pushing in the coin-roll drawer by hand, the diameter of the coin-roll can be identified accurately without experiencing no negative impact due to such change.

[0011] Therefore, only by drawing out/pushing in the coin-roll drawer, by hand, each kind of money of the coin-roll stored in the plurality of coin-roll storing portions can be judged accurately in a shorter time. Additionally, there is no need to provide an additional mechanism for moving the sensor at a constant speed, as conventional. Accordingly, the production cost for the coin-roll storing machine can be significantly reduced. It is noted that the management of the total amount of the coin-roll in the coin-roll storing machine can be carried out, in particular, based on the judgment to be provided when pushing in the coin-roll drawer.

[0012] In the coin-roll storing machine according to this invention, it is preferred that each of the coin-roll storing portions of the coin-roll drawer has an axis extending in the vertical direction and a cylindrical shape having a bottom face, the internal diameter of each coin-roll storing portion being slightly larger than the outer diameter of the coin-roll to be stored therein, and that a projection is selectively formed at the bottom face to extend vertically upward, depending on presence or absence of a hole of the coin-roll to be stored therein. Thus, inadvertent storage of the coin-roll, having a larger diameter, in an unmatched coin-roll storing portion can be prevented. In addition, if other kinds of coin-roll with no hole are inadvertently stored in the coin-roll storing portion in which apertured coin-roll are to be stored, they can not be stored therein because of block due to the projection against advance of such coin-roll. Therefore, such inadvertent storage of the coin-roll can be further prevented.

[0013] In the coin-roll storing machine according to this invention, it is preferred that each of the coin-roll storing portions of the coin-roll drawer has an axis extending in the vertical direction and a cylindrical shape having a bottom face, the internal diameter of each coin-roll storing portion being slightly larger than the outer diameter of

the coin-roll to be stored therein, and that a circular opening is formed in the bottom face to have an inner diameter slightly smaller than the outer diameter of the coin-roll to be stored therein. Thus, inadvertent storage of the coin-roll having an improperly larger diameter into the coin-roll storing portion with a smaller inner diameter can be prevented. Furthermore, if other coin-roll having a diameter quite smaller than the inner diameter of the coin-roll storing portion is inadvertently inserted therein, it will fall downward through the circular opening. Accordingly, inadvertent storage of such unduly smaller coin-roll in the coin-roll storing portion can also be prevented.

BRIEF DESCRIPTION OF THE DRAWINGS

[0014]

Fig. 1 is a block diagram showing one embodiment of a coin-roll storing machine according to the present invention, with the coin-roll storing machine incorporated in a change supplement and management system.

Fig. 2 is a perspective view showing the coin-roll storing machine and a coin change machine in the system shown in Fig. 1.

Fig. 3 is a perspective view of a portion of the coin-roll storing machine in the system shown in Fig. 1, when viewed from below.

Fig. 4 is a schematic view of displacement of one coin-roll drawer in the coin-roll storing machine shown in Figs. 2 and 3, with the drawer shown in (a) a closed position, (b) a pushed-in position, (c) a detection start/end position, (d) a detection end/start position, and (e) a fully-drawn-out position, respectively.

Fig. 5 is a side view schematically showing relationships between the respective coin-roll drawers and displacement detection means in the coin-roll storing machine shown in Figs. 2 and 3.

Fig. 6 shows cross sections illustrating the construction of the coin-roll storing portion in the coin-roll storing machine shown in Figs. 2 and 3, wherein Fig. 6 (a) shows a construction of the coin-roll storing portion adapted for one-yen coin-roll, ten-yen coin-roll, hundred-yen coin-roll, or five hundred-yen coin-roll, and Fig. 6(b) shows a construction of the coin-roll storing portion adapted for five-yen coin-roll or fifty-yen coin-roll.

Fig. 7 is a cross section showing another construction of the coin-roll storing portion in the coin-roll storing machine shown in Figs. 2 and 3.

Fig. 8 is a block diagram showing a control system of the coin-roll storing machine shown in Figs. 2 and 3.

DETAILED DESCRIPTION OF THE INVENTION

[0015] Hereinafter, one embodiment of the present in-

vention will be described with reference to the drawings. Figs. 1 to 8 are diagrams for illustrating one embodiment of a coin-roll (a roll of coins) storing machine according to the present invention and a change supplement and management system including the coin-roll storing machine.

[0016] Fig. 1 is a block diagram showing one embodiment of a coin-roll storing machine according to the present invention, with the coin-roll storing machine incorporated in a change supplement and management system. Fig. 2 is a perspective view showing the coin-roll storing machine and a coin change machine in the system shown in Fig. 1. Fig. 3 is a perspective view of a portion of the coin-roll storing machine in the system shown in Fig. 1, when viewed from below.

[0017] Fig. 4 is a schematic view of displacement of one coin-roll drawer in the coin-roll storing machine shown in Figs. 2 and 3, with the drawer shown in (a) a closed position, (b) a pushed-in position, (c) a detection start/end position, (d) a detection end/start position, and (e) a fully-drawn-out position, respectively. Fig. 5 is a side view schematically showing relationships between the respective coin-roll drawers and displacement detection means in the coin-roll storing machine shown in Figs. 2 and 3.

[0018] Fig. 6 shows cross sections illustrating the construction of the coin-roll storing portion in the coin-roll storing machine shown in Figs. 2 and 3, wherein Fig. 6 (a) shows a construction of the coin-roll storing portion adapted for one-yen coin-roll, ten-yen coin-roll, hundred-yen coin-roll, or five hundred-yen coin-roll, and Fig. 6(b) shows a construction of the coin-roll storing portion adapted for five-yen coin-roll or fifty-yen coin-roll. Fig. 7 is a cross section showing another construction of the coin-roll storing portion in the coin-roll storing machine shown in Figs. 2 and 3.

[0019] Fig. 8 is a block diagram showing a control system of the coin-roll storing machine shown in Figs. 2 and 3.

[0020] Hereinafter, through reference to Figs. 1 to 8, a construction of the change supplement and management system including the coin-roll storing machine of this embodiment, a specific construction of the coin-roll storing machine, a construction of the coin change machine in the system, and the operation and effect, and modifications of this embodiment, will be described, in succession.

[Construction of the change supplement and management system]

[0021] As shown in Fig. 1, the coin-roll storing machine 1 of this embodiment is combined with the coin change machine 3 and a POS resistor (point of sales resistor) 5, so as to constitute the change supplement and management system. As shown in Fig. 2, the coin-roll storing machine 1 of this embodiment is integrally juxtaposed to the coin change machine in the lateral direction. Specif-

ically, a storing main body 1a of the coin-roll storing machine 1 and a housing 3a of the coin change machine 3 are integrally formed relative to each other. The POS resistor 5 is located in the vicinity of the coin change machine 3 and the coin-roll storing machine 1.

[0022] As shown in Fig. 1, the coin-roll storing machine 1, coin change machine 3 and POS resistor 5 have control units 16, 36 and 50, respectively. Among them, the control unit 16 of the coin-roll storing machine 1 is connected in communication with the control unit 36 of the coin change machine 3, and the control unit 36 of the coin change machine 3 is in turn connected in communication with the control unit 50 of the POS resistor 5.

15 [Construction of the coin-roll storing machine]

[0023] As shown in Figs. 2 and 3, the coin-roll storing machine 1 includes the storing main body 1a, and three coin-roll drawers 11, 12, 13, respectively attached to the storing main body 1a, such that they can be independently drawn out in the forward direction (the horizontally longitudinal direction), by hand. These coin-roll drawers 11, 12, 13 are juxtaposed relative to each other in the horizontally lateral direction. In the respective coin-roll drawers 11, 12, 13, a plurality of coin-roll storing portions 14 (Fig. 2), each adapted to store coin-roll B therein, are provided. The coin-roll B are stored in each coin-roll storing portion 14 to have such an attitude that each axis of the coin-roll B is oriented in the direction vertical to the drawing direction (horizontally longitudinal direction) of the coin-roll drawers 11, 12, 13.

[0024] Specifically, for example, to the drawer 11 located on the most left side in Fig. 2, eight (8) coin-roll storing portions 14 adapted for one-yen coin-roll, and two (2) coin-roll storing portions 14 for five-yen coin-roll are provided. Besides, to the coin-roll drawer 2 located in an intermediate position as shown in Fig. 2, eight (8) coin-roll storing portions 14 adapted for ten-yen coin-roll, and two (2) coin-roll storing portions 14 for fifty-yen coin-roll are provided. Additionally, to the coin-roll drawer 13 located on the most right side in Fig. 2, eight (8) coin-roll storing portions 14 adapted for hundred-yen coin-roll, and two (2) coin-roll storing portions 14 for five-hundred yen coin-roll are provided.

[0025] As a representative of the above three coin-roll drawers 11, 12, 13, the construction of the respective coin-roll storing portions 14 provided to the coin-roll drawer 11 will be described with reference to Figs. 6(a) and 6(b). Fig. 6(a) shows the construction of the coin-roll storing portion 14 adapted for one-yen coin-roll, ten-yen coin-roll, hundred-yen coin-roll, or five hundred-yen coin-roll, and Fig. 6(b) shows the construction of the coin-roll storing portion 14 adapted for five-yen coin-roll or fifty-yen coin-roll.

[0026] As shown in Figs. 6(a) and 6(b), each coin-roll storing portion 14 of the coin-roll drawer 11 has an axis extending in the vertical direction, and is of a cylindrical shape having a bottom face. The inner diameter of each

coin-roll storing portion 14 is slightly larger than the outer diameter of the corresponding coin-roll B to be stored therein. Thus, inadvertent storage of the coin-roll B having an improperly large diameter in an unmatched coin-roll storing portion 14 can be prevented. Further, as shown in Fig. 6(b), in each coin-roll storing portion 14 for storing coin-roll B, for coins, each having a central hole, such as the five-yen coins or fifty-yen coins, a projection 14a is formed to extend vertically upward from the bottom face. In this manner, when storing the coin-roll B consisting of five-yen coins or fifty-yen coins are stored in the coin-roll storing portion 14, the hole of each coin constituting the coin-roll B is fitted around the projection 14a. Thus, because of the block against advance of the coin-roll B due to the projection 14a, other kinds of coin-roll B consisting of coins with no holes can not be stored in the coin-roll storing portions 14 configured for the five-yen coins or fifty-yen coins. Therefore, such inadvertent storage of the coin-roll B can be further prevented.

[0027] As another construction of each coin-roll storing portion 14 of the coin-roll drawer 11, one as shown in Fig. 7 can be mentioned. The coin-roll storing portion 14 as shown in Fig. 7 has an inner diameter slightly larger than the outer diameter of the coin-roll B to be stored therein. In addition, in the bottom face of the coin-roll storing portion 14, a circular opening 14b is formed with an inner diameter slightly smaller than the outer diameter of the coin-roll B to be stored in the coin-roll storing portion 14. In this way, inadvertent storage of the coin-roll B having a diameter larger than the inner diameter of the coin-roll storing portion 14 can be prevented. Furthermore, if other coin-roll B having a diameter quite smaller than the inner diameter of the coin-roll storing portion 14 is stored therein, it will fall downward through the circular opening 14b. Accordingly, inadvertent storage of such smaller diameter coin-roll B in the coin-roll storing portion 14 can also be prevented.

[0028] As a still another construction of each coin-roll storing portion 14 of the coin-roll drawer 11, the coin-roll storing portion 14 having the projection 14a as shown in Fig. 6(b) may be used for five-yen coin-roll or fifty-yen coin-roll, while the other coin-roll storing portion 14 having the circular opening 14b as shown in Fig. 7 may be used for one-yen coin-roll, ten-yen coin-roll, hundred-yen coin-roll and five-hundred-yen coin-roll.

[0029] The coin-roll storing machine 1 includes a detection system 18 (Fig. 1) for detecting a signal, for use in judging presence or absence of coin-roll B and the kind of the coins, for each coin-roll storing portion 14 of the coin-roll drawers 11, 12, 13. The detection system 18 is configured to judge the presence or absence of coin-roll B and the kind of the coins for each coin-roll storing portion 14, both in the case where each of the coin-roll drawers 11, 12, 13 is pushed into the storing main body 1a and in the case where each of the pushed in coin-roll drawers 11, 12, 13 is drawn out from the storing main body 1a.

[0030] The control unit 16 has a function as a judgment

means for judging the presence or absence and the kind of money of the coin-roll B stored in each coin-roll storing portion 14 of the particular coin-roll drawer 11, 12, 13, based on a signal outputted from the detection system 18.

[0031] As described herein, the coin-roll taken out from each coin-roll drawer 11, 12, 13 of the coin-roll storing machine 1 will be referred to as "taken-out coin-roll".

[0032] As shown in Fig. 3, the storing main body 1a of the coin-roll storing machine 1 includes a frame body F adapted to hold the respective coin-roll drawers 11, 12, 13 such that they can individually slide in the horizontally longitudinal direction. At a bottom portion of each coin-roll drawer 11, 12, 13, an optically transparent portion (not shown) is provided. Each optically transparent portion extends over a range, in which the plurality of coin-roll storing portions 14 in each coin-roll drawer 11, 12, 13 are provided, as well as, it extends up to a point in the vicinity of a distal end of the coin-roll drawer distal to the most forward coin-roll storing portion 14. As shown in Figs. 3 and 5, at the bottom face of each coin-roll drawer 11, 12, 13, a rack R is provided, extending in the longitudinal direction.

[0033] In Fig. 4, various longitudinal positions are shown, on the basis of a front face panel 1c (see Fig. 2) of the storing main body 1a of the coin-roll drawer 11, which is exemplified as a representative of the aforementioned three coin-roll drawers 11, 12, 13.

[0034] Namely, Fig. 4 illustrates, respectively:

a position (a), which is a "closed position", wherein the front face of the coin-roll drawer 11 is positioned to be flush with the front face panel 1c;

a position (b), which is a "pushed-in position", wherein the coin-roll drawer 11 is further pushed in from the closed position, and thus the front face of the coin-roll drawer 11 is slightly retracted from the front face panel 1c;

a position (c), which is a "detection start/end position", wherein detection due to the detection system 18 is started when drawing out the coin-roll drawer 11, and the detection due to the detection system 18 is ended when pushing in the coin-roll drawer 11;

a position (d), which is a "detection end/start position", wherein the detection due to the detection system 18 is ended when drawing out the coin-roll drawer 11, and the detection due to the detection system 18 is started when pushing in the coin-roll drawer 11; and

a position (e), which is a "fully-drawn-out position", wherein the coin-roll drawer 11 is fully drawn out, such that the storage/taking out of the coin-roll B relative to all of the coin-roll storing portions 14 (Fig. 2) of the coin-roll drawer 11 can be carried out.

[0035] As a typical example of the detection system 18 (Fig. 1), a coin-roll diameter sensor S1, as will be described below, is shown in Fig. 4.

[0036] As shown in Fig. 3, at a front portion of the frame

body F, one coin-roll diameter sensor S1 and three coin-roll hole sensors S21, S22, S23 are provided. The coin-roll diameter sensor S1 comprises a light emitting unit and a light receiving unit, respectively fixed to the frame F (storing main body 1a) in the lateral direction, in positions opposed to each other, with the coin-roll B interposed between them, wherein the coin-roll B are respectively stored in the three coin-roll drawers 11, 12, 13, in each raised state. The coin-roll diameter sensor S1 is located such that its light axis passes through a position forward to the most forward coin-roll storing portion 14 of each coin-roll drawer 11, 12, 13 in the closed position (Fig. 4(a)) (see Figs. 4 and 5).

[0037] The coin-roll hole sensors S21, S22, S23 are provided, respectively corresponding to the coin-roll drawers 11, 12, 13. Each coin-roll hole sensor S21, S22, S23 comprises a light emitting unit and a light receiving unit, respectively fixed to the frame F (storing main body 1a), in positions opposed to each other in the vertical direction, with each corresponding coin-roll drawer 11, 12, 13 interposed between them. Each coin-roll hole sensor S21, S22, S23 is located such that its light axis passes through the axis of the coin-roll B stored in each corresponding coin-roll drawer 11, 12, 13, such that they can be taken out and pushed in, while being in each raised state.

[0038] Additionally, on one side face near the bottom portion of the frame F, a single two-phase rotary encoder E is provided. As shown in Figs. 3 and 5, the rotary encoder E has an input axis e1 extending in the horizontally lateral direction. To the input axis e1, three pinions P respectively corresponding to the coin-roll drawers 11, 12, 13 are fixed. The racks R of the coin-roll drawers 11, 12, 13 and the corresponding pinions P are respectively arranged such that they can be engaged with each other at least when the coin-roll drawers 11, 12, 13 are in positions between the detection start/end position (Fig. 4 (c)) and the detection end/start position (Fig. 4(d)) (i.e., positions within a range necessary for judgment by a judging means between the closed portion (Fig. 4 (a)) and the fully-drawn-out position (Fig. 4 (e)), while not engaged with each other at least when the coin-roll drawers 11, 12, 13 are in the respective closed positions.

[0039] Thus, the rotary encoder E may be configured to output pulse signals of a number in proportion to the displacement in the longitudinal direction of each coin-roll drawer 11, 12, 13. Namely, the rotary encoder E, racks R and pinions P constitute together a displacement detection means for detecting the displacement in the longitudinal direction of each coin-roll drawer 11, 12, 13 relative to the storing main body 1a.

[0040] As shown in Fig. 8, the coin-roll diameter sensor S1, coin-roll hole sensors S21, S22, S23 and rotary encoder E, which constitute together the detection system 18, are respectively connected to the control unit 16. Also, to the control unit 16, a memory (storage means) M and a communication interface T are connected. In the memory M, relationships between positions of the respective

coin-roll storing portions 14 and the kinds of coin-roll B to be stored in the respective coin-roll storing portions 14, in all of the coin-roll drawers 11, 12, 13, are inputted in advance. The communication interface T is adapted to connect the control unit 36 of the coin change machine 3 (Fig. 1) in communication with the control unit 16.

[0041] The control unit 16 has a function as a judgment means for judging presence or absence and the kind of money of the coin-roll B stored in the respective coin-roll storing portions 14 of each coin-roll drawer, based on the displacement in the longitudinal direction of either one of the coin-roll drawers 11, 12, 13 to be identified from the output of the rotary encoder E as well as on the respective outputs from the coin-roll diameter sensor S1 and coin-roll hole sensors S21, S22, S23.

[0042] Specifically, when drawing out one of the coin-roll drawers by hand from the storing main body 1a, or when pushing it into the storing main body 1a by hand, the rotary encoder E, coin-roll diameter sensor S1 and coin-roll hole sensor S21, S22, S23 corresponding to the respective coin-roll drawer, output pulse signals, respectively. Of these output signals, by using the pulse signal of the rotary encoder E, the displacement, in the longitudinal direction relative to the storing main body 1a, of each coin-roll drawer 11, 12, 13 is identified, as such the displacement in the longitudinal direction relative to the respective coin-roll sensors S1; S21, S22, S23 of the coin-roll storing portions 14 can be identified. Further, by using the pulse signals of the respective coin-roll sensors S1; S21, S22, S23, transition of light transmission/shading (presence or absence of shading) due to the radial outer periphery and inner periphery of the respective coin-roll B (or only the outer periphery in the cases of coins other than the five-yen coins and fifty-yen coins) can be identified.

[0043] Consequently, not only the presence or absence of the coin-roll B but also the diameter and presence or absence of the central hole of the coin-roll B stored can be identified for each coin-roll storing portion 14 of the coin-roll drawers 11, 12, 13. Based on the identification, the control unit 16 can judge whether the kind of coin-roll B present in a certain coin-roll storing portion 14 is adequate or not to be stored therein.

[Construction of the coin change machine]

[0044] As shown in Figs. 1 and 2, the coin change machine 3 includes a slot 30 provided in a front portion of the housing 3a, a delivery port 34, and a display and operation panel 3b (Fig. 2). Further, as shown in Fig. 1, the coin change machine 3 includes an identification means 31, a selection means 32 and a coin storing portion 33 in which respective coins are classified for their kinds. The identification means 31 is configured to identify the kinds and the number of loose coins to be put into the slot 30. The selection means 32 is configured to sort the loose coins, having been identified, by the identification means 31, for each kind of money. The coin storing

portion 33 is configured to store the loose coins, having been sorted by the selection means 32, therein, while classifying them for the respective kinds.

[0045] The coin change machine 3 is configured to feed the loose coins stored in the coin storing portion 33 into the delivery port 34, depending on the need for delivering the change or the like. As the loose coins to be put into the slot 30, in addition to coins (typically, loose coins to be obtained by removing wrapping for taken-out coin-roll) supplemented as those used for changes, coins received from customers are also included. However, it is not critical to discriminate them, but instead, they may be stored together in the coin storing portion 33 so as to be utilized as changes.

[0046] To the control unit 36 of the coin change machine 3, judgment results is transmitted from the control unit 16 of the coin-roll storing machine 1. The control unit 36 has a function for comparing the kind and the number of loose coins identified by the identification means 31 with the kind and the number of taken-out coin-roll based on the judgment results received, as well as for managing the correspondence between the both.

[0047] The judgment results are also transmitted to the control unit 50 of the POS resistor 5, from the control unit 16 of the coin-roll storing machine 1, via the control unit 36 of the coin change machine 3.

[0048] If the kind and the number of the loose coins does not correspond to the kind and the number of the taken-out coin-roll (i.e., if the coins are the same kind, but the total number of the loose coins is not coincidence with the total number of the taken-out coin-roll to be calculated by multiplying the number of coins (usually fifty) per package of the coin-roll by the number of packages of the coin-roll), some address, such as flagging to a log data of the change supplement and management system, will be taken. Consequently, the correspondence between the taken-out coin-roll and the loose coins supplemented as changes can be managed accurately. Instead of using the control unit 36 of the coin change machine 3, a function for managing such a correspondence may be provided to the control unit 50 of the POS resistor 5.

[0049] It should be appreciated that the coin-roll B to be stored in the coin-roll storing machine 1 are not limited to those wrapped into a package consisting of fifty NIPPON-yen coins, but may be those wrapped into a package consisting of a predetermined number of coins other than the NIPPON-yen coins, for example, U.S. or Euro coins. Specifically, with respect to a package of coin-roll consisting of U.S. coins, for example, a one-cent coin-roll package consists of fifty one-cent coins, a five-cent coin-roll package consists of forty five-cent coins, a ten-cent coin-roll package consists of fifty ten-cent coins, a twenty-five-cent coin-roll package consists of forty twenty-five-cent coins, a fifty-cent coin-roll package consists of twenty fifty-cent coins, and one-dollar coin-roll package consists of twenty one-dollar coins.

[0050] With respect to the Euro coins, for example, a

one-cent coin-roll package consists of fifty one-cent coins, a two-cent coin-roll package consists of fifty two-cent coins, a five-cent coin-roll package consists of fifty five-cent coins, a ten-cent coin-roll package consists of forty ten-cent coins, a twenty-cent coin-roll package consists of forty twenty-cent coins, a fifty-cent coin-roll package consists of twenty fifty-cent coins, a one euro coin-roll package consists of twenty-five one-euro coins, and a two-euro coin-roll package consists of twenty-five two-euro coins.

[0051] In the case where the coin-roll to be stored in the coin-roll storing machine 1 are coins other than Nippon-yen coins, such as U.S. or Euro coins, information concerning the number of coins per coin-roll package of such U.S. or Euro coins, for each kind of money, is inputted in advance to the memory M of the control unit 16. In this way, when calculating the total amount of the coin-roll B stored in the coin-roll storing machine 1 by using the control unit 16 of the coin-roll storing machine 1 and/or by using control unit 50 of the POS resistor 5, with consideration as to information concerning the kinds and the number of coin-roll B to be obtained and calculated by the control unit 16 of the coin-roll storing machine 1, as well as concerning the number of coins per coin-roll package, for each kind of money, of each country, stored in the memory M, the total amount of coin-roll B stored in the coin-roll storing machine 1 can be automatically calculated.

[Operation and effect]

[0052] Next, the operation and effect of the coin-roll storing machine of this embodiment constructed as described above will be discussed.

[0053] According to the coin-roll storing machine 1 of this embodiment, the coin-roll B can be stored in each coin-roll storing portion 14, while orienting each axis of the coin-roll B to be vertical to the coin-roll storing portion 14. Thus, the dimension in the width direction of the storing main body 1a can be significantly reduced, as compared with the type of storing the coin-roll B in each coin-roll storing portion 14, while putting them on the bottom face in the horizontal direction. This can facilitate to ensure an installation space for the coin-roll storing machine 1. In addition, in the case where the coin-roll storing machine 1 is arranged in a juxtaposition to the coin change machine 3 as shown in Fig. 2, the dimension in the width direction of the entire body of the resultant supplement and management system can also be reduced.

[0054] According to the coin-roll storing machine 1 of this embodiment, when drawing out or pushing in the particular coin-roll drawer 11, 12, 13 relative to the storing main body 1a, based on the longitudinal displacement of each coin-roll drawer 11, 12, 13 to be identified from the output of the rotary encoder E as the displacement detection means as well as on each output of the coin-roll diameter sensor S1 and coin-roll hole sensors S21, S22, S23 depending on the presence or absence of shading

due to the coin-roll B, the control unit 16 as the judgment means judges the presence or absence and the kind of money of the coin-roll B stored in each coin-roll storing portion 14 of the coin-roll drawer. In this case, the kind of money of the coin-roll B can be judged, on the basis of the diameter of the coin-roll B to be identified based on the longitudinal displacement of each coin-roll drawer 11, 12, 13 and the output of the coin-roll diameter sensor S1, as well as on the basis of the presence or absence of the central hole of the coin-roll B to be identified based on the output of each coin-roll hole sensor S21, S22, S23. Thus, by utilizing the longitudinal displacement of each coin-roll drawer 11, 12, 13, even though there is some change of speed during drawing out/pushing in the coin-roll drawer by hand, the diameter of the coin-roll B can be identified accurately without experiencing no negative impact due to such change.

[0055] Therefore, only by pushing in the particular coin-roll drawer 11, 12, 13, by hand, the kind of money of the coin-roll B stored in the plurality of coin-roll storing portions 14 of each coin-roll drawer can be judged accurately in a shorter time, thereby to grasp the total amount of the money. Additionally, there is no need to provide a mechanism for moving the sensor at a constant speed as conventional. Accordingly, the production cost for the coin-roll storing machine can be significantly reduced. Furthermore, the longitudinal displacement of the plurality of coin-roll drawers 11, 12, 13 can be detected respectively by using the single rotary encoder E. Therefore, the production cost of the displacement detection means can also be reduced, leading to further reduction of the production cost of the coin-roll storing machine.

[Modifications]

[0056] It should be appreciated that the coin-roll storing machine 1 of this embodiment is not limited to the aspect described above, but various modifications may be added thereto.

[0057] For example, in the aspect described above, while the case wherein the control unit 16 of the coin-roll storing machine 1 has the function as the judgment means has been discussed, the control unit 36 of the coin change machine 3 or the control unit 50 of the POS resistor 5 may instead be configured to have a function as such a judgment means.

[0058] While the case wherein each pinion P is fixed to the input axis e1 of the rotary encoder E has been described, each pinion P may not be fixed to the input axis e1, provided that it can be rotated together with the input axis e1. For example, another gear or axis may be provided between each pinion P and the input axis e1.

[0059] Additionally, the coin-roll hole sensors S21, S22, S23 may be omitted, in the case where apertured coins are not included in the coin-roll B to be stored, and/or in the case where the difference of the diameter is sufficiently large between the respective kinds of coin-roll B, as such the judgment of the kind of money can be

performed enough only by using the output of the coin-roll diameter sensor S1.

[0060] The coin-roll drawers 11, 12, 13 may be constructed with respectively separated units so as to be detachable from the storing main body 1a and/or from other coin-roll drawers. In such a case, a further drawer unit may be added to the coin-roll storing machine 1 which includes the three coin-roll drawers as shown in Fig. 2, or otherwise, the unit of the coin-roll drawer 13, for example, may be removed as needed.

Claims

1. A coin-roll storing machine, comprising:
 - a storing main body; and
 - a coin-roll drawer which is provided such that it can be drawn out relative to the storing main body, and having a plurality of coin-roll storing portions, each for storing coin-roll with each axis of coin-roll being oriented in the vertical direction.
2. The coin-roll storing machine according to claim 1, wherein the coin-roll drawer is configured such that it can be drawn out, by hand, in the horizontally longitudinal direction, between its closed position and its drawn-out position, relative to the storing main body.
3. The coin-roll storing machine according to claim 2, further comprising:
 - a displacement detection means for detecting the displacement in the longitudinal direction of the coin-roll drawer relative to the storing main body;
 - a coin-roll diameter sensor including a light emitting unit and a light receiving unit respectively fixed to the coin-roll storing main body in positions opposed to each other across an area through which the coin-roll stored in the coin-roll drawer will pass, during drawing out and pushing in the coin-roll drawer, the coin-roll diameter sensor being adapted to output a signal corresponding to presence or absence of shading due to the coin-roll; and
 - a judgment means for judging the number and the kind of money of the coin-roll stored in each coin-roll storing portion of the coin-roll drawer, based on the displacement in the longitudinal direction of the coin-roll drawer to be detected by the displacement detection means as well as on the output of the coin-roll diameter sensor.
4. The coin-roll storing machine according to claim 1, wherein each of the coin-roll storing portions of the

coin-roll drawer has an axis extending in the vertical direction and a cylindrical shape having a bottom face, the internal diameter of each coin-roll storing portion being slightly larger than the outer diameter of the coin-roll to be stored therein, and wherein a projection is selectively formed at the bottom face to extend vertically upward, depending on presence or absence of a hole of the coin-roll to be stored therein.

5

- 5. The coin-roll storing machine according to claim 1, wherein each of the coin-roll storing portions of the coin-roll drawer has an axis extending in the vertical direction and a cylindrical shape having a bottom face, the internal diameter of each coin-roll storing portion being slightly larger than the outer diameter of the coin-roll to be stored therein, and wherein a circular opening is formed in the bottom face to have an inner diameter slightly smaller than the outer diameter of the coin-roll to be stored therein.

10

15

20

25

30

35

40

45

50

55

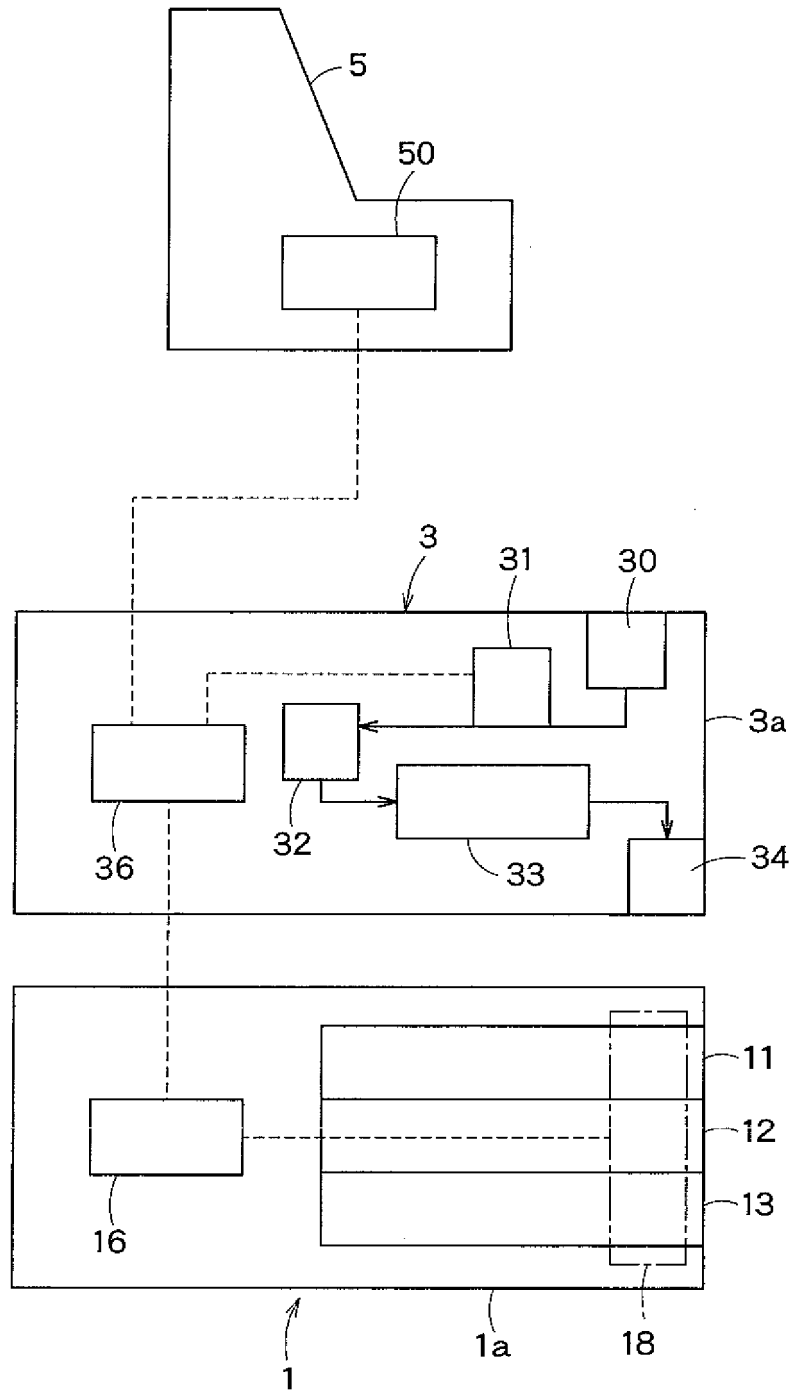

FIG. 1

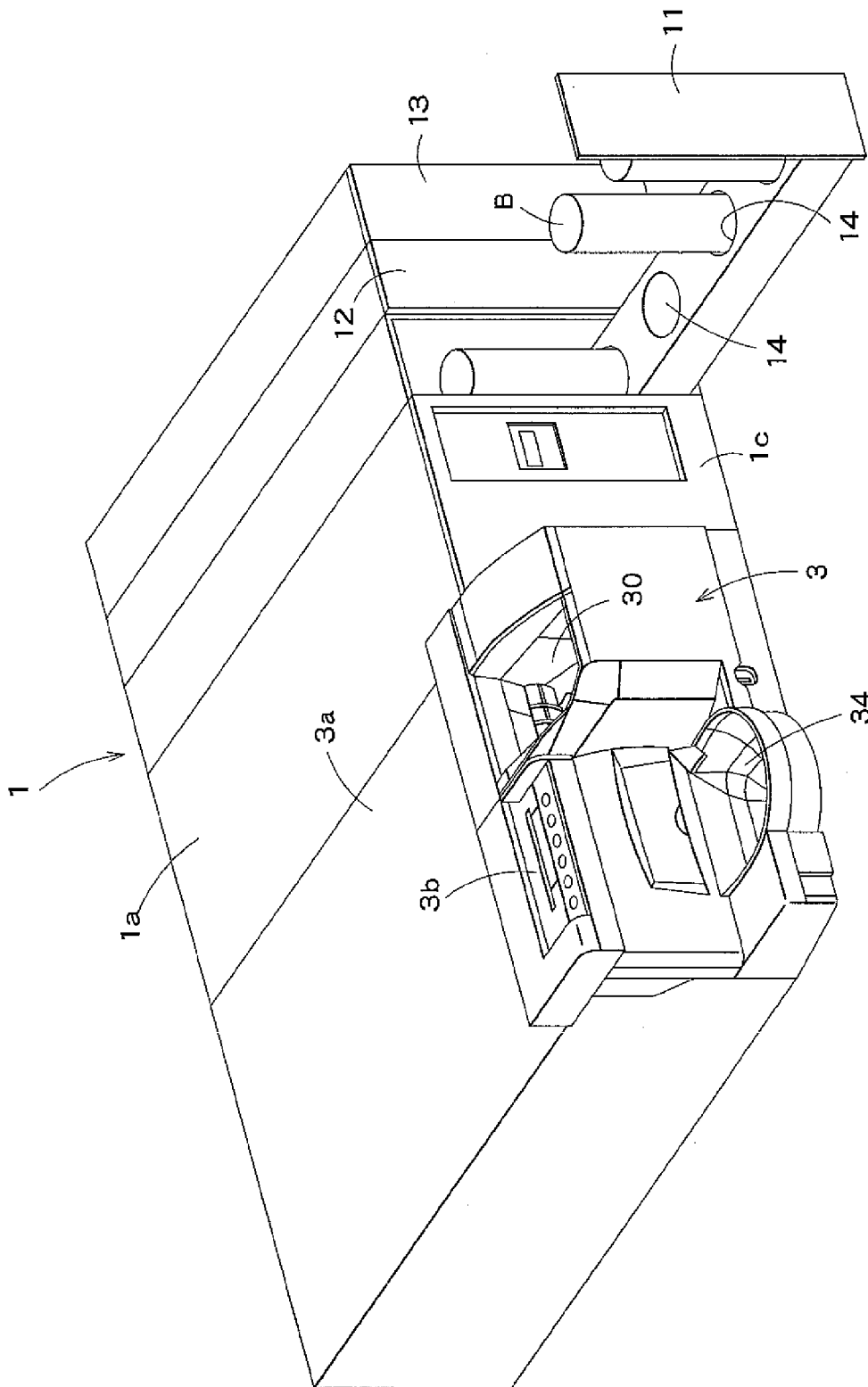

FIG. 2

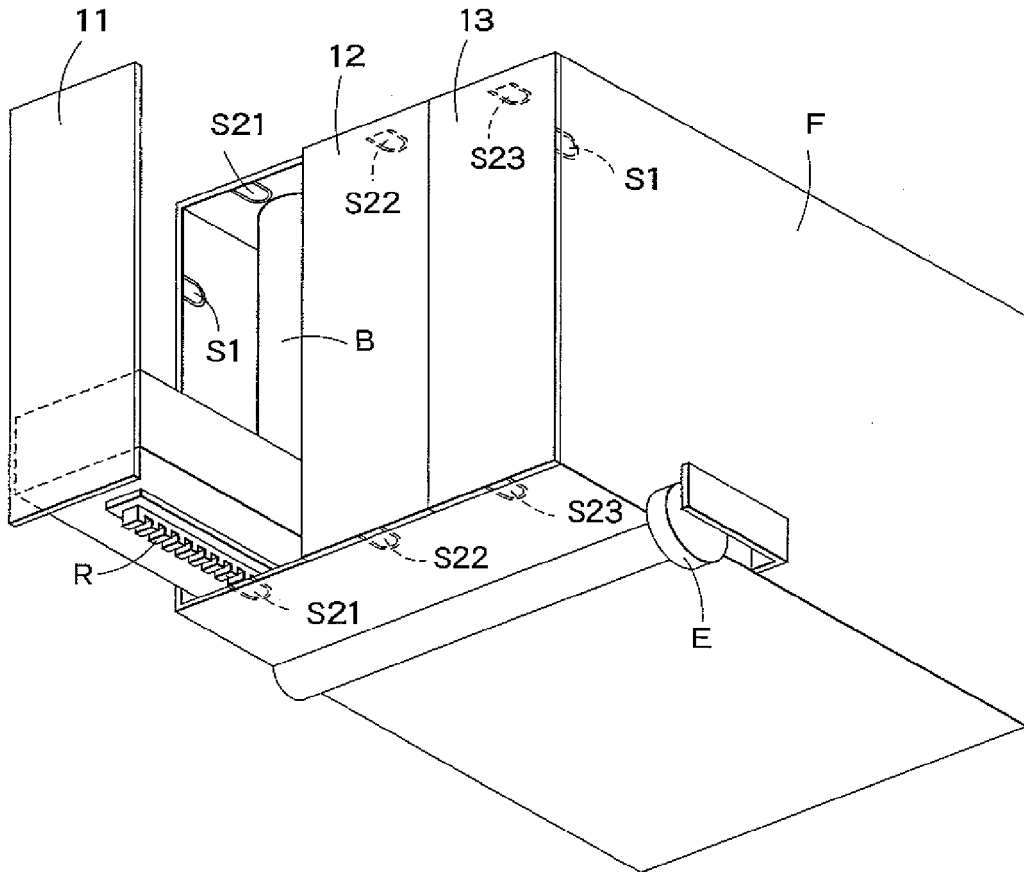

FIG. 3

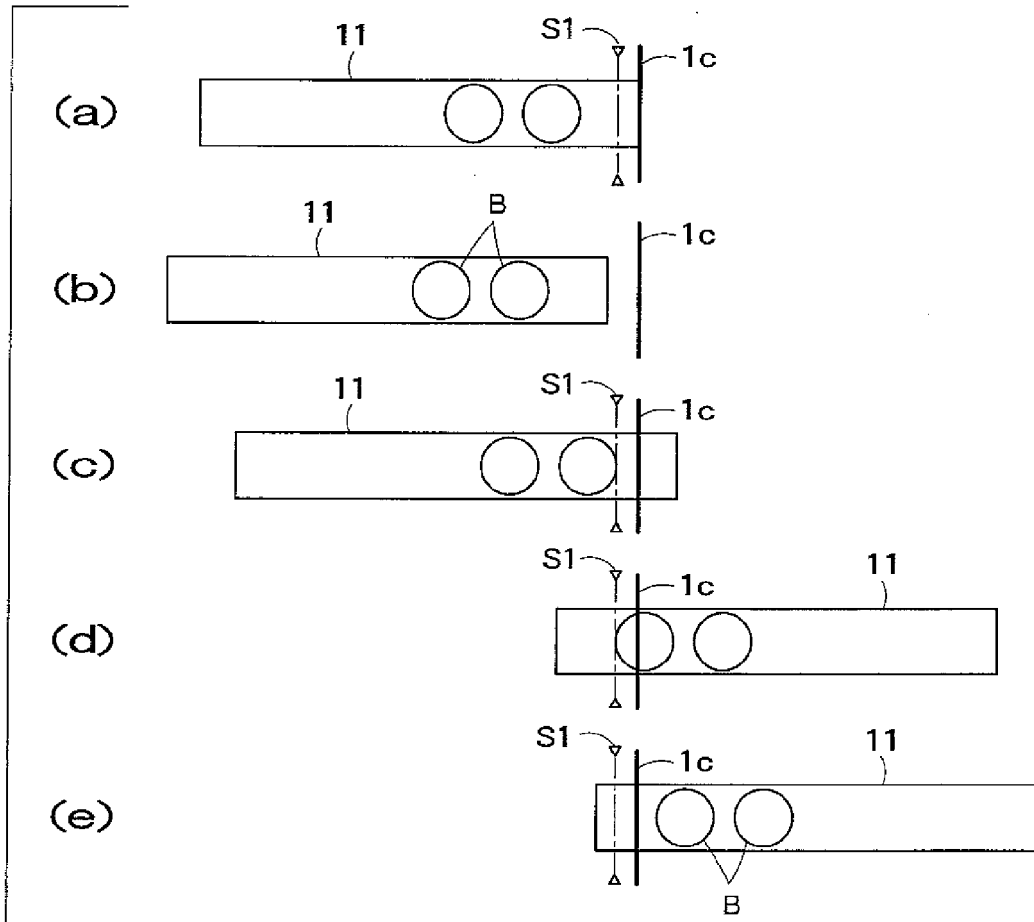

FIG. 4

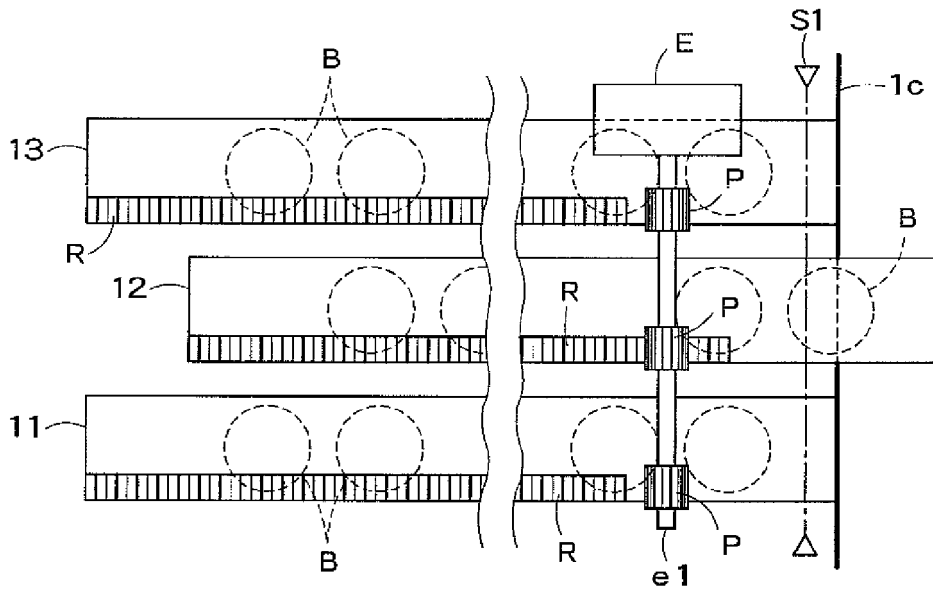

FIG. 5

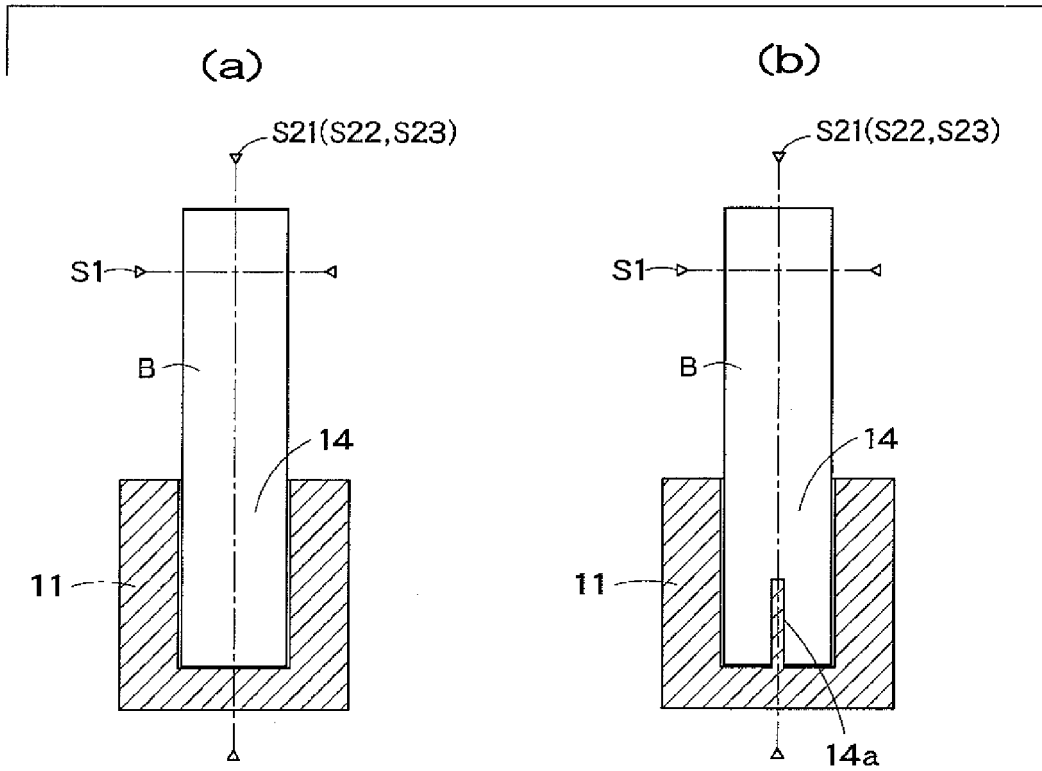

FIG. 6

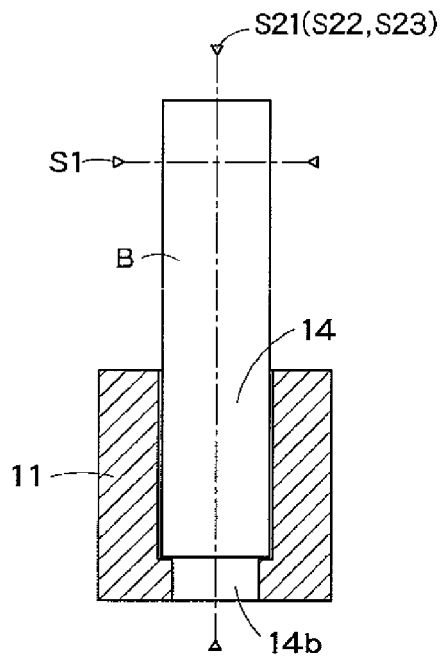

FIG. 7

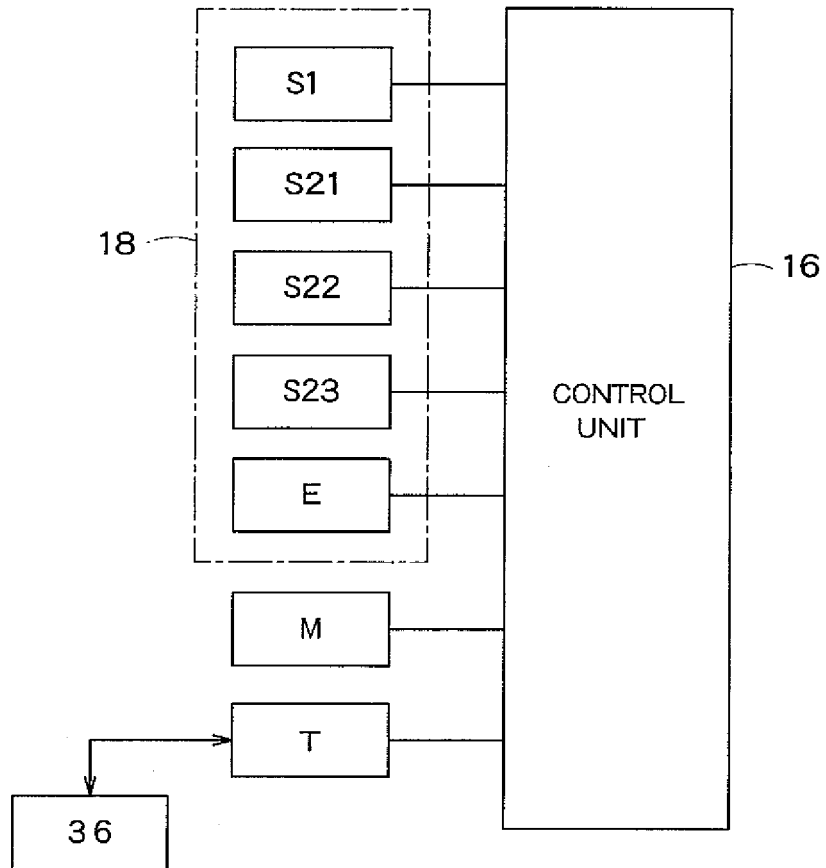

FIG. 8

REFERENCES CITED IN THE DESCRIPTION

This list of references cited by the applicant is for the reader's convenience only. It does not form part of the European patent document. Even though great care has been taken in compiling the references, errors or omissions cannot be excluded and the EPO disclaims all liability in this regard.

Patent documents cited in the description

- JP 11250314 A [0002] [0002]
- JP 2006085332 A [0002] [0002]