

(12) **United States Patent**
Thompson-Buist

(10) **Patent No.:** **US 10,039,334 B2**
(45) **Date of Patent:** **Aug. 7, 2018**

(54) **REMOVABLE, INTERCHANGEABLE, MOISTURE RETAINING, FRICTION REDUCING HEAD-WEAR LINING**

(71) Applicant: **Yolanda Thompson-Buist**, Hoogezand (NL)

(72) Inventor: **Yolanda Thompson-Buist**, Hoogezand (NL)

(*) Notice: Subject to any disclaimer, the term of this patent is extended or adjusted under 35 U.S.C. 154(b) by 163 days.

(21) Appl. No.: **15/257,683**

(22) Filed: **Sep. 6, 2016**

(65) **Prior Publication Data**

US 2018/0064196 A1 Mar. 8, 2018

(51) **Int. Cl.**
A42C 5/00 (2006.01)
A42C 5/04 (2006.01)
A42B 1/20 (2006.01)
A42B 1/04 (2006.01)

(52) **U.S. Cl.**
CPC **A42B 1/205** (2013.01); **A42B 1/041** (2013.01)

(58) **Field of Classification Search**
CPC A42B 1/205; A42B 1/041; A42B 1/069
See application file for complete search history.

(56) **References Cited**

U.S. PATENT DOCUMENTS

1,050,310 A * 1/1913 Picker et al. A42B 1/066
2/172
8,819,867 B1 * 9/2014 Boada A42B 1/24
2/171
2005/0268382 A1* 12/2005 Epling A42B 1/069
2/411
2017/0042268 A1* 2/2017 Lessard A42B 1/041

* cited by examiner

Primary Examiner — Kristen Matter

(74) *Attorney, Agent, or Firm* — Chen-Chi Lin

(57) **ABSTRACT**

The present invention is a removable, reusable and interchangeable multi-shell lining configured for placement within a hat member, cap or any sort of head-wear for adjustable thermal comfort, moisture retention, reduction of friction thus reducing frizz and breakage of naturally dry and curly hair. The lining is comprised of a satin outer shell, satin-encased thermal middle shell and waterproof inner shell. The three shells, which are not bonded together, provide optimal moisture retention, reduction of friction of hair and thermal comfort. The three constituent shells are intended for contact with the wearer, can be interchanged and or used as a single shell lining while still maintaining hair moisture and reducing hair frizz and breakage.

3 Claims, 4 Drawing Sheets

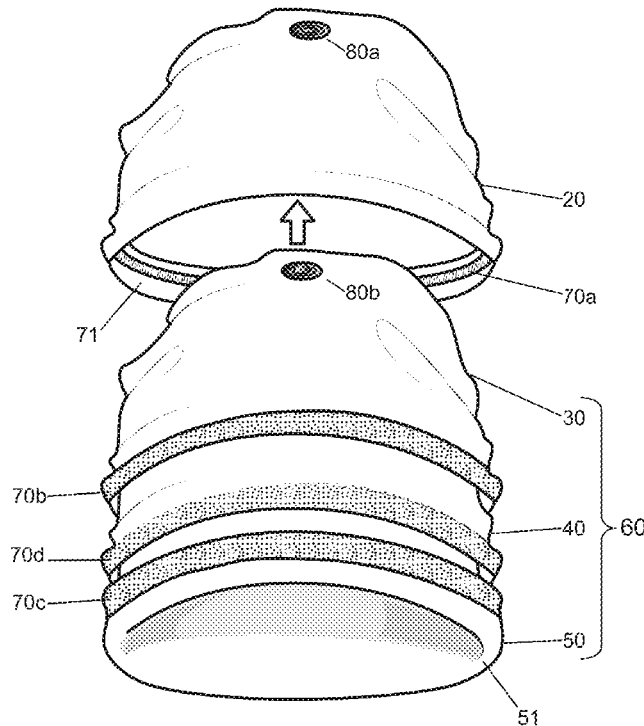

FIG. 1

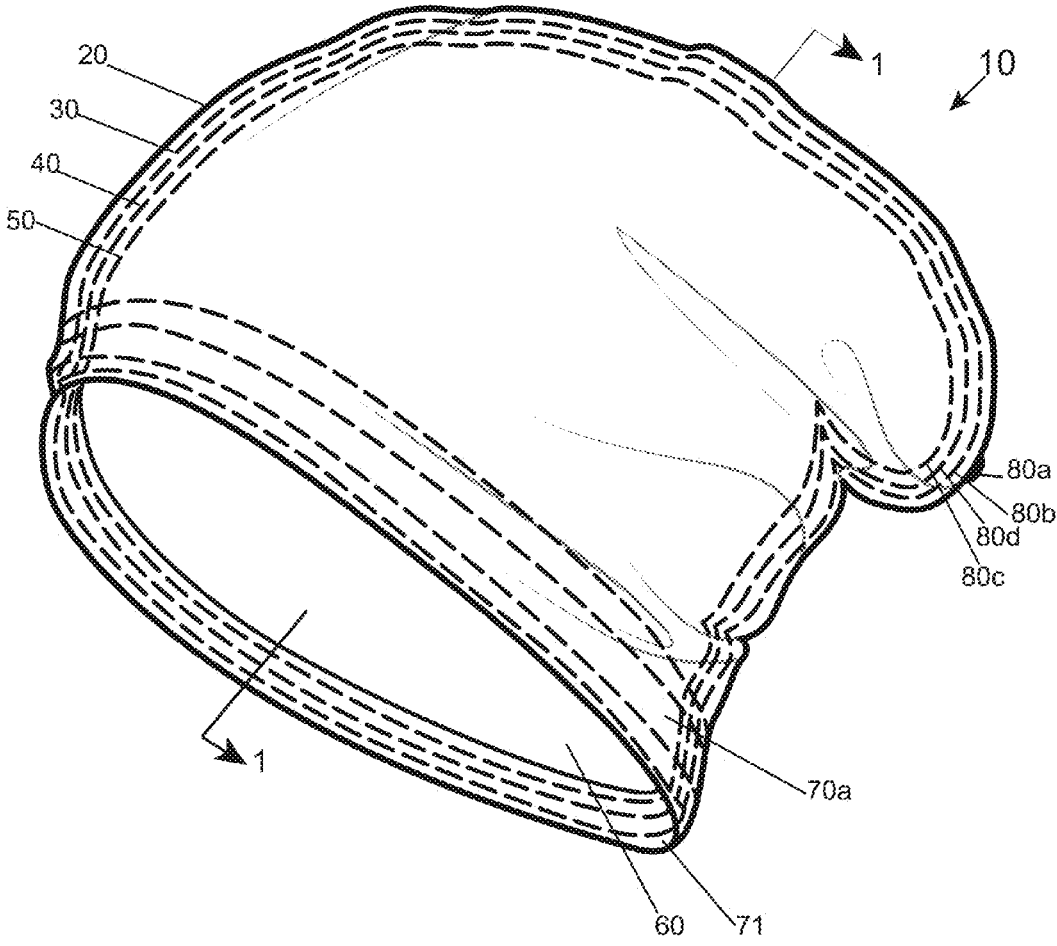
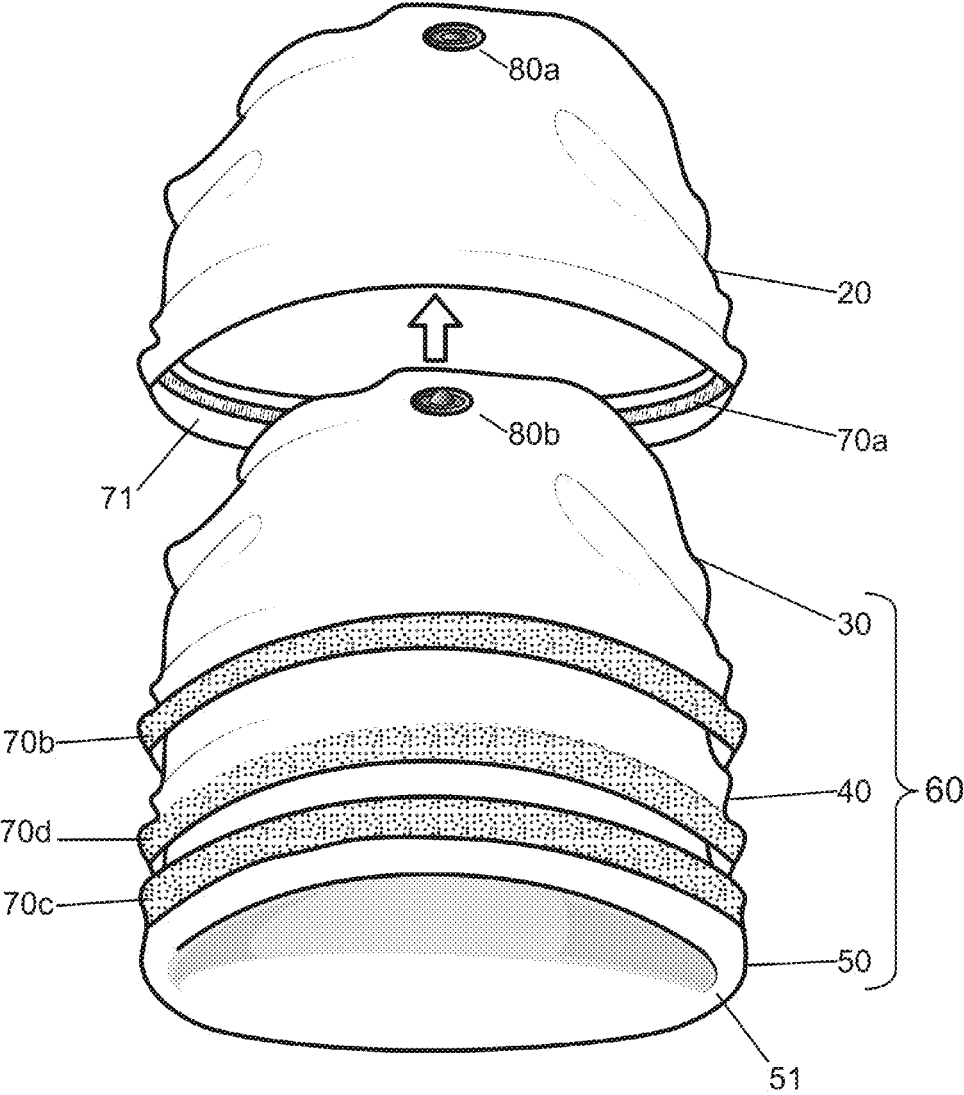
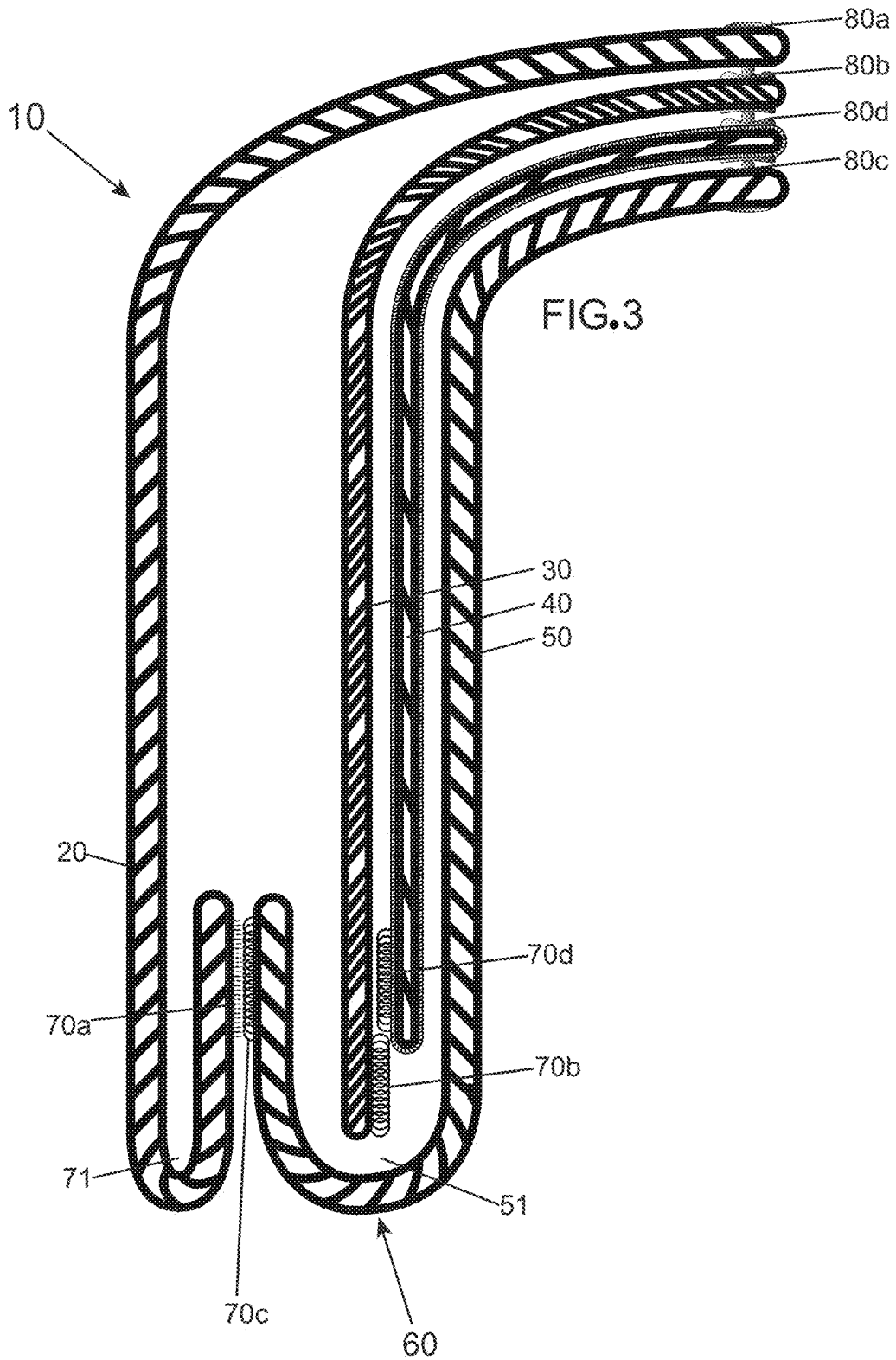
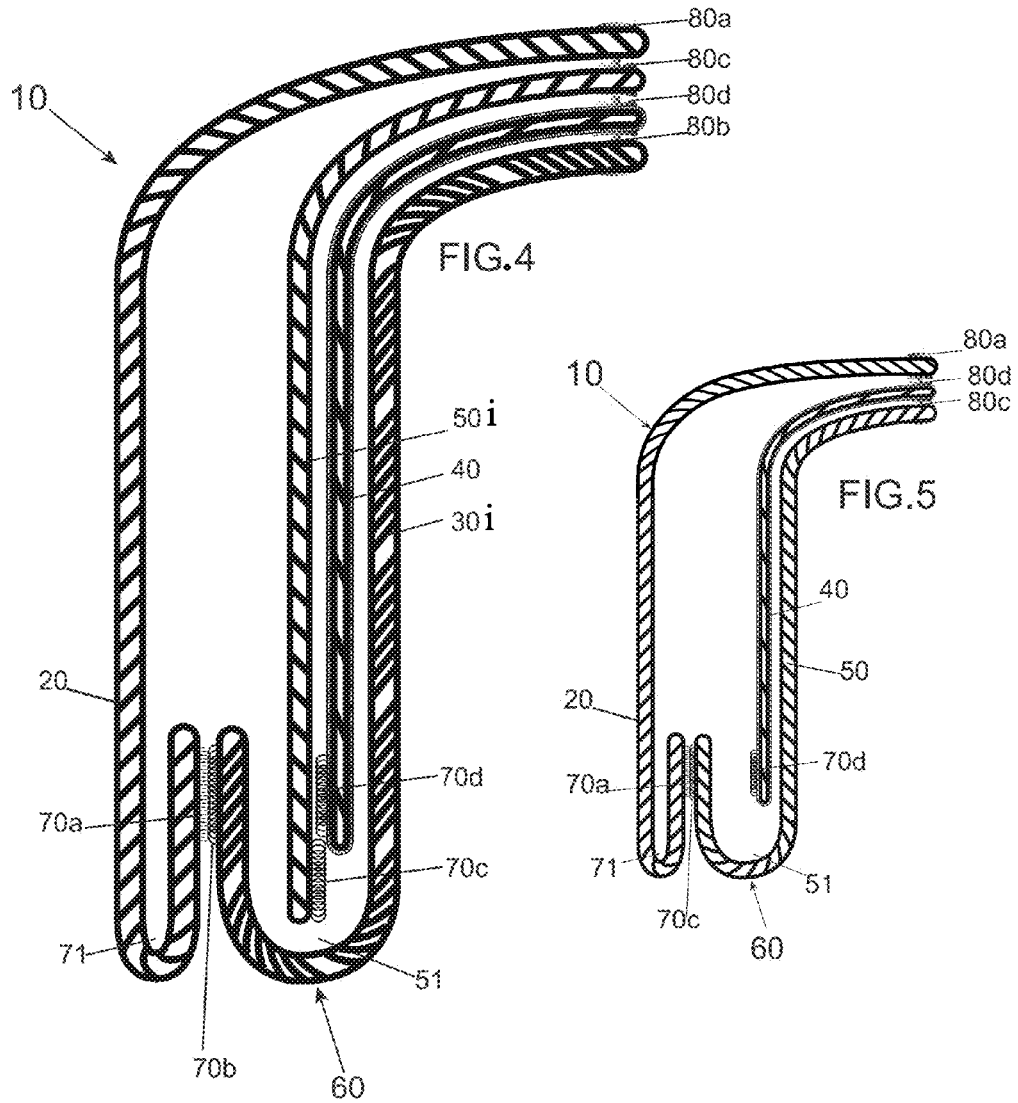

FIG.2







1

**REMOVABLE, INTERCHANGEABLE,
MOISTURE RETAINING, FRICTION
REDUCING HEAD-WEAR LINING**

CROSS-REFERENCE TO RELATED
APPLICATIONS

Not Applicable.

FEDERALLY SPONSORED RESEARCH OR
DEVELOPMENT

Not Applicable.

INCORPORATION BY REFERENCE OF
MATERIAL PRESENTED ON A COMPACT
DISC

Not Applicable.

BACKGROUND OF THE INVENTION

Various types of removable head-wear linings are known however what is needed is a removable, reusable, interchangeable, multi-shell head-wear lining assembly for dry and curly hair that retains hair moisture, reduces friction against hair strands while allowing the wearer to easily control thermal comfort.

FIELD OF INVENTION

The present invention relates to a removable, reusable and interchangeable head-wear lining assembly and more particularly to shells that help retain moisture and reduce friction against dry and curly hair with adjustable insulation acting together as one optimal lining or separately as individual linings.

SUMMARY OF THE INVENTION

The purpose of the present invention, described subsequently in further detail, features a removable, reusable, interchangeable head-wear lining assembly. The inventive lining is configured for placement within a hat member, cap or any sort of head-wear for moisture retention, reduction of friction thus reducing frizz and breakage of naturally dry and curly hair and for adjustable thermal comfort. To achieve this the lining is comprised of three shell components which are made from choice performance materials. The three constituent shells, which are not bonded together, provide optimal moisture retention, frizz and breakage reduction of hair and thermal comfort for the wearer. All three shells are suitable for contact with the wearer and can be interchanged and or used as a single shell lining while still maintaining hair moisture and reducing hair frizz and breakage.

A first outer shell created for direct contact with the wearer is a non-wicking satin material such as polyester or alternatively silk; this breathable, friction reducing outer shell aids in retaining moisture which is beneficial to dry and curly hair. A second middle shell is a thin multi-membrane thermal fabric which provides warmth to the hair and head of the wearer. This shell is created for direct contact with the wearer by encasing it in a similar or same choice performance material used for the first outer shell. The third inner shell also created for direct contact with the wearer is a waterproof fabric. This waterproof fabric does not wick away moisture and allows wet hair to retain its high levels

2

of moisture while keeping the hat member dry. The three shells are removable, reusable and interchangeable and can be worn as a single shell lining inside the cap, hat member or head-wear.

BRIEF DESCRIPTION OF THE DRAWINGS

FIG. 1 is an isometric side view.

FIG. 2 is an exploded frontal view.

FIG. 3 is a cross sectional view along line 1-1 of FIG. 1.

FIG. 4 modified form

FIG. 5 modified form

DETAILED DESCRIPTION OF THE
INVENTION

With reference now to the drawings and in particular FIG. 1 through FIG. 5 thereof, a preferred embodiment of the head-wear assembly designated by reference number 10 is shown. The present invention 60 is a removable, reusable, interchangeable lining configured specifically for placement in head-wear 20 and is comprised of a composite of three dome shaped shells 30, 40, 50 with continuous, elongated walls. Because naturally dry hair and curly hair are more susceptible to damage from head-wear which wicks away moisture and causes friction the inventive head-wear lining 60 is created to maintain the moisture levels of naturally dry and curly hair and reduce friction which causes frizzing and breakage of said dry and curly hair. Most head-wear is created from materials that wick away moisture and create friction against hair strands causing the hair's cuticles to lift; this lifting can cause hair to frizz, dry out and become even more prone to breaking. The performance properties of each shell 30, 40, 50 in the present inventive lining 60 combine for optimal hair moisture retention, warmth and reduction of frizz and hair breakage.

In order to prevent dry and curly hair from being damaged by head-wear 20 it is necessary to have a lining 60 which is made from performance materials that are highly compatible to such easily damaged hair. The composite of shells that make up the lining 60 are comprised of choice performance material. The outer shell 30, of the lining 60, intended for contact with the wearer is created from a material that is a satin which helps maintain moisture instead of wicking a majority of it away and reduce frizz and breakage of hair. Satin is a specific weave of natural and synthetic fibers and this weave creates a fabric with a highly smooth surface. Silk a natural, breathable material and polyester can be weaved as satin and are the preferred materials used for the first outer shell. The highly, smooth surface of the satin material glides across hair strands creating little to no friction. Because there is little to no friction created by the outer shell 30 the hair cuticles do not lift which prevents moisture from escaping the hair's cortex. The reduced friction is also beneficial to the hair strand not breaking due to brittleness from continued drying out. The outer shell 30 of the inventive lining 60 can be used in combination with the thermal middle shell 40 and the thermoplastic polyurethane inner shell 50 or alone as a single shell described subsequently in further detail.

The middle shell component 40 of the lining 60 is a thin material with thermal properties. Thin thermal fabrics act by either reflecting body heat back towards the body with reflective fabrics or by capturing body heat within tight weaves and holding on to it. The preferred thermal fabric is one that is very thin, flexible and soft with a high warmth-to-thickness ratio. The thermal fabric blocks radiant heat

loss with its fine microfibers capturing the heat generated from the wearer while also being a breathable material. The thermal middle shell **40** is adapted to come in contact with the wearer by encasing it in the same or a similar performance material used for the outer shell, a non wicking satin. The thermal middle shell **40** sits within the outer shell **30** as the inner shell **50** sits within the thermal middle shell **40**. The thermal middle shell does not impede the ability of the outer shell **30**, **70b** or inner shell **50**, **70c** from attaching to the head-wear **20**, **70a** via a hook and loop attachment system. The middle thermal shell **40** also has its own means of attachment at the crown **80d** and peripheral edge **70d** of the shell for securing it to the head-wear **20**.

The purpose of the thermal middle shell **40** is to create warmth for the wearer and hair with conditioner or oil on it. Those with dry and curly hair will typically deep condition their hair for extended periods of time, including overnight. It is suggested that heat helps conditioner and oil penetrate the hair shaft. The warmth maintained by a thin thermal shell **40** will radiate heat back towards the wearer's hair and thus aid in deep conditioning the hair. A great advantage to having composite shells that are not permanently joined is that in hotter temperatures the thermal middle shell **40** can be easily removed, as well as a choice of the outer shell **30** or inner shell **50**, allowing for a head-wear assembly which is cooler in hotter temperatures.

The third inner shell **50** of the inventive lining **60** is a waterproof material such as, but not limited to, thermoplastic polyurethane (TPU) which is a very thin, flexible, soft and smooth material with high elasticity. This material is waterproof as well as oil and grease resistant. A large percentage of those with dry and curly hair use oils to help seal in the moisture of their hair strands. Oils can sometimes breakdown and erode waterproof barriers and stain fabrics. Thermoplastic polyurethane hence forth referred to as TPU is a perfect choice for dry and curly hair because of its combination of waterproofing and oil resistance.

The TPU inner shell **50**, of the inventive lining **60**, enables those with damp hair to deep condition or perform hot oil treatments while wearing their head-wear and the combination of the TPU shell **50** along with the thermal middle shell **40** allows for a deeper conditioning and or prolonged hot oil treatment due to the warmth of the thermal middle shell **40**. TPU has a highly smooth surface that eliminates friction and thus aids in reducing frizz and hair breakage. The TPU shell **50** is intended for contact with the wearer and does not wick away moisture but rather retains it due to its' waterproofing nature. It can be appreciated by one skilled in the art that the TPU inner shell **50** and the satin outer shell **30** can be chemically bonded essentially creating a reversible liner which is still within the scope of the invention.

The inner shell **50**, **70c**, middle shell **40**, **70d** and outer shell **30**, **70b** lining **60** secure to the head-wear **20**, **70a** via means of an attachment system. The attachment system **70a**, **70b**, **70c**, **70d** illustrated in FIG. 2 and FIG. 3 is a hook and loop system but those skilled in the art should recognized it could also be, but is not limited to, snap buttons and zippers to name but a few different kinds of attachment systems. The headwear **20** inside hem **71** holds the hook side **70a** of the attachment system while the outer shell **30**, **70b**, middle shell **40**, **70d** and the inner shell **50**, **70c** have loops attached to their peripheral edges of the elongated, continuous walls. At the crown of the head-wear **20**, **80a** there is also a female part of a snap button system to prevent sagging. The snap part **80a** of the head-wear **20** attaches to the male snap button parts of the satin outer shell **80b**, thermal middle shell **80d** and the TPU inner shell **80c**. Those skilled in the art will

recognize that this attachment system can also be but is not limited to a hook and loop system as well as other various attachment systems.

Although the orientation of the shells creating the lining can be interchanged, as seen in FIG. 4, there is nevertheless, for purposes of disclosure, a preferred embodiment as illustrated by FIG. 1-FIG. 3 where the outer shell **30** connects via a snap button attachment system located on its exterior crown **80b** to the interior crown of the head-wear **20**, **80a**. This crown snap button attachment **80a**, **80b** prevents the outer shell **30** from collapsing inwards. The middle shell **40** sits within the outer shell **30** and the inner shell **50** sits within the middle shell. Both the outer shell **30** and middle shell **40** peripheral edges sit within a shallow pocket **51** created from the inner shell **50** peripheral edge being folded outwards from its cavity and up. The inner shell **50**, **70c** attaches to the head-wear **20**, **70a** via the attachment hook and loop system.

The satin outer shell **30** of FIG. 3 can be interchanged with the TPU inner shell **50** of FIG. 3, as seen in FIG. 4, thus becoming the inner shell **30i** of FIG. 4. This satin inner shell **30i** will then sit within the thermal middle shell **40** as the thermal middle shell **40** sits within the TPU outer shell **50i**. The satin inner shell's peripheral edge **70b** with attachment loops then folds outwards from its cavity and up creating a shallow pocket which holds the peripheral edges of the thermal middle shell **40** and the now TPU outer shell **50i**. This fold enables the satin inner shell **30i**, **70b** peripheral edge with loop to attach to the head-wear **20**, **70a** hook. To prevent the crown from collapsing in this configuration the TPU outer shell **50i**, **80c** fastens via the snap button attachment system to the head-wear **20**, **80a**.

If the wearer desires to have minimum moisture retention and no warmth while still reducing friction then the TPU inner shell **50** along with the thermal middle shell **40** can be quickly and easily removed allowing the satin outer shell **30** to be used solely as a single shell lining. The satin shell would then attach to the head-wear **20**, **70a**, **80a** via its loop **70b** and snap button part **80b**. As shown in FIG. 5 a composite of two shells, the middle thermal shell **40** with either the satin outer shell **30** or as illustrated in FIG. 5 the inner TPU shell **50** can also be formed to suit the wearer's needs of warmth and moisture retention with either dry hair or wet hair. Other orientations of the lining **60** are the thermal middle shell **40** and the TPU inner shell **50** worn as single shell linings that still maintain moisture, reduce friction and thus reduce frizzing and drying of dry and curly hair while giving added warmth in the case of the thermal middle shell **40**.

Other modifications and changes with different assembly will be apparent to those skilled in the art, the invention is not considered limited to the given examples chosen for purposes of disclosure and covers all changes and modifications which do not constitute a departure from the true spirit and scope of the invention which is to retain hair moisture and reduce friction against hair while allowing for easy thermal control. For example the removable, reusable and interchangeable multi-shell lining can be bonded together creating a reversible triple shell lining that is not interchangeable but remains within the scope of the invention. A TPU lining can be added as the sole liner of a hat, cap or head-wear for purposes of deep conditioning and hot oil treatments with or without a means of attaching and detaching it so that it can be interchanged with a satin lining or satin-encased thermal lining. One skilled in the art will also recognize that a head scarf can be adapted to have the aforementioned shells, lining, layers.

What is claimed is:

1. A headwear assembly comprising:
 an article of headwear comprising an attachment system
 at both a peripheral edge and crown thereof; and
 three shells comprising an inner shell, a middle shell and
 an outer shell, the three shells being interchangeable 5
 and being of dome shaped shells,
 the inner shell comprising a waterproof material con-
 figured to retain moisture on hair of a wearer during
 sleep conditioning and hot oil treatments, 10
 the middle shell comprising a thermal fabric configured
 to increase warmth of a head of the wearer,
 the outer shell comprising satin or silk configured to
 reduce friction and maintain moisture of the hair of
 the wearer, 15
 each shell of the three shells comprising an attachment
 system at both a peripheral edge and crown thereof
 configured to selectively attach said each shell to at
 least one other of the three shells and/or the article of
 headwear to customize moisture and thermal levels 20
 for the wearer;

wherein the three shells are configured to be secured together with the article of headwear to achieve maximum moisture retention and warmth during use.

2. The headwear assembly of claim 1, wherein the attach- 25
 ment system at the peripheral edge of each shell and the
 attachment system at the peripheral edge of the article of
 headwear include hook and loop fasteners.

3. The headwear assembly of claim 2, wherein the attach- 30
 ment system at the crown of each shell and the attachment
 system at the crown of the article of headwear include snap
 fasteners.

* * * * *