



US00D944753S

(12) **United States Design Patent**
Akana et al.

(10) **Patent No.:** **US D944,753 S**
(45) **Date of Patent:** **** Mar. 1, 2022**

(54) **ELECTRONIC DEVICE**

(71) Applicant: **Apple Inc.**, Cupertino, CA (US)

(72) Inventors: **Jody Akana**, San Francisco, CA (US);
Molly Anderson, San Francisco, CA (US);
Bartley K. Andre, Palo Alto, CA (US);
Shota Aoyagi, San Francisco, CA (US);
Anthony Michael Ashcroft, San Francisco, CA (US);
Marine C. Bataille, San Francisco, CA (US);
Jeremy Bataillou, San Francisco, CA (US);
Markus Diebel, San Francisco, CA (US);
M. Evans Hankey, San Francisco, CA (US);
Julian Hoenig, San Francisco, CA (US);
Richard P. Howarth, San Francisco, CA (US);
Jonathan P. Ive, San Francisco, CA (US);
Julian Jaede, San Francisco, CA (US);
Duncan Robert Kerr, San Francisco, CA (US);
Peter Russell-Clarke, San Francisco, CA (US);
Benjamin Andrew Shaffer, San Jose, CA (US);
Mikael Silvanto, San Francisco, CA (US);
Sung-Ho Tan, San Francisco, CA (US);
Clement Tissandier, San Francisco, CA (US);
Eugene Antony Whang, San Francisco, CA (US);
Rico Zörkendörfer, San Francisco, CA (US)

(73) Assignee: **Apple Inc.**, Cupertino, CA (US)

(**) Term: **15 Years**

(21) Appl. No.: **29/739,012**

(22) Filed: **Jun. 22, 2020**

Related U.S. Application Data

(63) Continuation of application No. 29/705,040, filed on Sep. 9, 2019.

(51) **LOC (13) Cl.** **14-03**

(52) **U.S. Cl.**

USPC **D14/138 G**

(58) **Field of Classification Search**

USPC D14/125-134, 137, 138 R, 138 AA, D14/138 AB, 138 AC, 138 AD, 138 C, D14/138 G, 147, 203.1-203.8, 217, 218, D14/238.1, 247, 248, 250, 257, 299, D14/315-318, 332, 336, 341-347, 371, D14/374-377, 388, 389, 420, 424, 426, D14/429, 432, 489, 492, 496, 425, D14/433-453, 464, 468, 469, 471, 511; D6/300-310; D10/50, 65, 98, 104.1; D16/241; D17/24, 99; D18/4.6, 6; D20/10, 19, 39; D21/329, 330, 517
CPC . A63H 33/3016; G06F 1/1613; G06F 1/1641; G06F 1/1643; G06F 1/1647; G06F 1/1626; G06F 3/04883; G06F 3/0486; G06F 3/04847; G06F 3/04845; G06F 3/0484; G06F 3/04817; H04B 1/3838; H04M 1/0235; H04M 1/0237; H04M 1/0239; H04M 1/0268; H04M 1/027; H04M 1/0295; H04M 1/02; H04M 1/0279; H04M 1/0277; H04M 1/0266; H04M 1/0202; H04M 1/026; H04M 1/0281; H04M 1/0283; H04N 13/045; H05K 5/0017; H05K 5/02; H05K 5/0217; H05K 5/0004

See application file for complete search history.

(56)

References Cited

U.S. PATENT DOCUMENTS

D337,569 S	7/1993	Kando
D420,354 S	2/2000	Morales
D504,889 S	5/2005	Andre et al.
D548,732 S	8/2007	Cebe et al.
D558,756 S	1/2008	Andre et al.
D558,757 S	1/2008	Andre et al.
D558,758 S	1/2008	Andre et al.
D573,143 S	7/2008	Park et al.
D580,387 S	11/2008	Andre et al.
D597,067 S	7/2009	Oh et al.
D599,342 S	9/2009	Andre et al.
D600,241 S	9/2009	Andre et al.
D602,014 S	10/2009	Andre et al.
D602,015 S	10/2009	Andre et al.

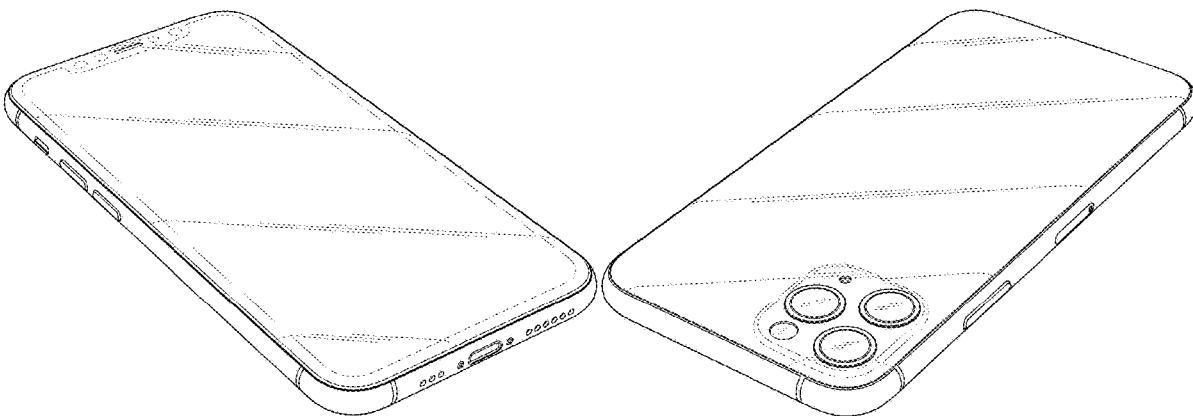

US D944,753 S

D602,017 S	10/2009	Andre et al.	D706,776 S	6/2014	Akana et al.
D602,488 S	10/2009	Jiang et al.	D707,223 S	6/2014	Akana et al.
D603,834 S	11/2009	Lyman et al.	D708,608 S	7/2014	Sugiyama et al.
D604,297 S	11/2009	Andre et al.	D710,815 S	8/2014	Kim et al.
D608,750 S	1/2010	He et al.	8,804,353 B2	8/2014	Montevirgen et al.
D613,736 S	4/2010	Andre et al.	D712,384 S	9/2014	Hibi
7,697,281 B2	4/2010	Dabov et al.	D712,405 S	9/2014	Akana et al.
D618,204 S	6/2010	Andre et al.	D713,833 S	9/2014	Wilkey
D619,555 S	7/2010	Yang et al.	D718,268 S	11/2014	Wu et al.
D622,270 S	8/2010	Andre et al.	8,879,245 B2	11/2014	Kim
D622,718 S	8/2010	Andre et al.	D719,941 S	12/2014	Kim et al.
D622,719 S	8/2010	Andre et al.	D720,747 S	1/2015	Kim et al.
D625,307 S	10/2010	Cheng	D721,344 S	1/2015	Lee et al.
D626,937 S	11/2010	Yeo et al.	8,933,347 B2	1/2015	Kiple et al.
D627,344 S	11/2010	Chien et al.	D724,572 S	3/2015	Wildner
D627,769 S	11/2010	Kumagai	8,989,826 B1	3/2015	Connolly
D627,778 S	11/2010	Akana et al.	D731,481 S	6/2015	Akana et al.
D631,028 S	1/2011	Park et al.	D732,497 S	6/2015	Lee et al.
D631,458 S	1/2011	Liao et al.	D732,498 S	6/2015	Huang et al.
D633,461 S	3/2011	Kim et al.	D732,539 S	6/2015	Akana et al.
D633,493 S	3/2011	Akana et al.	D733,146 S	6/2015	Akana et al.
D633,908 S	3/2011	Akana et al.	D736,205 S	8/2015	Park et al.
D635,113 S	3/2011	Park et al.	D739,391 S	9/2015	Chen et al.
D635,952 S	4/2011	Park et al.	D741,279 S	10/2015	Tai et al.
D636,390 S	4/2011	Andre et al.	D742,351 S	11/2015	Chen et al.
D636,392 S	4/2011	Akana et al.	D743,391 S	11/2015	Akana et al.
D636,752 S	4/2011	Liao et al.	D744,993 S	12/2015	Diebel
D638,003 S	5/2011	Chen	D746,275 S	12/2015	Mohammad
D638,815 S	5/2011	Lee et al.	D747,287 S	1/2016	Chang et al.
D639,261 S	6/2011	Garnham et al.	D749,563 S	2/2016	Akana et al.
D639,763 S	6/2011	Kim et al.	9,256,252 B2	2/2016	Chao
D639,771 S	6/2011	Chen	D750,620 S	3/2016	Zhai
D640,663 S	6/2011	Arnholt et al.	D750,729 S	3/2016	Sheikh et al.
D642,563 S	8/2011	Akana et al.	D751,051 S	3/2016	Cho et al.
D648,303 S	11/2011	Park et al.	D752,010 S	3/2016	Kim
D649,968 S	12/2011	Li	D752,037 S	3/2016	Akana et al.
D653,645 S	2/2012	Park	9,274,142 B2	3/2016	Nickel et al.
D654,887 S	2/2012	McManigal et al.	D754,125 S	4/2016	Akana et al.
D656,477 S	3/2012	Yi et al.	D759,008 S	6/2016	Akana et al.
D662,503 S	6/2012	Akana et al.	D760,217 S	6/2016	Akana et al.
D668,627 S	10/2012	Chung	D761,226 S	7/2016	Poulin
D671,905 S	12/2012	Mauritzson	D762,207 S	7/2016	Akana et al.
D671,937 S	12/2012	Akana et al.	D762,610 S	8/2016	Joung et al.
D672,343 S	12/2012	Jody	D767,522 S	9/2016	Wu et al.
D673,562 S	1/2013	Johnson	D769,208 S	10/2016	Ho et al.
D676,432 S	2/2013	Hasbrook et al.	9,462,094 B2	10/2016	Liu et al.
D677,641 S	3/2013	Sutherland et al.	D770,411 S	11/2016	Zhang
D677,642 S	3/2013	Park	D770,433 S	11/2016	Kangasmaa et al.
D677,657 S	3/2013	Akana et al.	D771,607 S	11/2016	Kim et al.
D680,092 S	4/2013	Tsai et al.	D771,622 S	11/2016	Akana et al.
D680,984 S	4/2013	Harmon et al.	D771,623 S	11/2016	Akana et al.
D680,995 S	4/2013	Lee	D772,865 S	11/2016	Akana et al.
D681,032 S	4/2013	Akana et al.	D774,499 S	12/2016	Fathollahi
D681,632 S	5/2013	Akana et al.	D777,700 S	1/2017	Kwon et al.
D683,711 S	6/2013	Hofer et al.	9,537,219 B2	1/2017	Ayala et al.
D684,571 S	6/2013	Akana et al.	D778,867 S	2/2017	Husgafvel et al.
D686,586 S	7/2013	Cho et al.	D779,484 S	2/2017	Akana et al.
D687,404 S	8/2013	Yoshimura	9,577,318 B2	2/2017	Pascolini et al.
D687,793 S	8/2013	Park	D780,748 S	3/2017	Wang
D688,218 S	8/2013	Lee	D781,807 S	3/2017	Hubbard et al.
D688,221 S	8/2013	Zuffo et al.	9,594,147 B2	3/2017	Han et al.
D688,660 S	8/2013	Akana et al.	D783,565 S	4/2017	Kim et al.
D689,455 S	9/2013	Daniel	D783,566 S	4/2017	Kim et al.
8,526,180 B2	9/2013	Rayner	D783,602 S	4/2017	Akana et al.
D690,693 S	10/2013	Akana et al.	D784,314 S	4/2017	Ryu et al.
D691,133 S	10/2013	Akana et al.	D784,315 S	4/2017	Ryu et al.
D692,881 S	11/2013	Akana et al.	D786,229 S	5/2017	Kim et al.
D693,324 S	11/2013	Wang	D790,535 S	6/2017	Akana et al.
D693,785 S	11/2013	Sutherland et al.	D792,366 S	7/2017	Zhang et al.
D696,247 S	12/2013	Kim	D792,386 S	7/2017	Lee et al.
D697,911 S	1/2014	McManigal et al.	D794,623 S	8/2017	Kwon et al.
D698,770 S	2/2014	Park	D796,497 S	9/2017	Kim et al.
D698,773 S	2/2014	Wildner	9,761,927 B2	9/2017	Kasar et al.
8,640,868 B2	2/2014	O'Dowd et al.	D798,851 S	10/2017	Kim et al.
D702,219 S	4/2014	Suk	D798,852 S	10/2017	Kim et al.
D705,188 S	5/2014	Chau et al.	D800,710 S	10/2017	Ryu et al.
D706,235 S	6/2014	Kim	D800,716 S	10/2017	Akana et al.
D706,251 S	6/2014	Park	D801,321 S	10/2017	Kim et al.
D706,301 S	6/2014	Akana et al.	D803,209 S	11/2017	Akana et al.

D805,495 S 12/2017 Kester et al.
 D806,705 S 1/2018 Akana et al.
 D810,715 S 2/2018 Cho et al.
 D815,612 S * 4/2018 Shin D14/138 G
 D828,322 S * 9/2018 Ryu D14/138 G
 D831,017 S * 10/2018 Choe D14/248
 D831,625 S * 10/2018 Cho D14/248
 D835,620 S 12/2018 Akana et al.
 D849,707 S * 5/2019 Choi D14/138 G
 D868,059 S * 11/2019 Akana D14/341
 D890,153 S * 7/2020 Kim D14/248
 D890,713 S * 7/2020 Xu D14/138 G
 D895,626 S * 9/2020 Akana D14/439
 D896,232 S * 9/2020 Akana D14/439
 D901,479 S * 11/2020 Altschul D14/250
 D903,622 S * 12/2020 Fujimura D14/138 G
 D905,065 S * 12/2020 Akana D14/439
 2009/0247244 A1 10/2009 Mittleman et al.
 2011/0050560 A1 3/2011 Foster et al.
 2011/0117971 A1 5/2011 Kim et al.
 2011/0268218 A1 11/2011 Kang et al.
 2012/0088555 A1 4/2012 Hu
 2012/0168577 A1 7/2012 Cheng
 2012/0170189 A1 7/2012 Li et al.
 2012/0329535 A1 12/2012 Kuo
 2013/0321237 A1 12/2013 Woodhull et al.
 2013/0331156 A1 12/2013 Lui
 2016/0191095 A1 6/2016 Santelli

FOREIGN PATENT DOCUMENTS

CN 300928488 S 5/2009
 CN 301134880 S 2/2010
 CN 301139661 S 2/2010
 CN 301161836 S 3/2010
 CN 301271887 S 6/2010
 CN 301300814 S 8/2010
 CN 301794564 S 1/2012
 CN 301867415 S 3/2012
 CN 302242618 S 12/2012
 CN 302268386 S 1/2013
 CN 302279529 S 1/2013
 CN 302321988 S 2/2013
 CN 302333118 S 2/2013
 CN 302350915 S 3/2013
 CN 302404040 S 4/2013
 CN 302430473 S 5/2013
 CN 202998218 U 6/2013
 CN 302455942 S 6/2013
 CN 302476338 S 6/2013
 CN 302560014 S 9/2013
 CN 302588771 S 9/2013
 CN 302606411 S 10/2013
 CN 302619300 S 10/2013
 CN 302748579 S 2/2014
 CN 302808732 S 4/2014
 CN 302873818 S 7/2014
 CN 302982246 S 10/2014
 CN 303000183 S 11/2014
 CN 303000194 S 11/2014
 CN 303453788 S 11/2015
 CN 303617715 S 3/2016
 CN 303647864 S 4/2016
 CN 303774339 S 8/2016
 CN 303805687 S 8/2016
 CN 304095914 S 4/2017
 CN 304095915 S 4/2017
 CN 304130421 S 5/2017
 DM 095015 2/2017
 EM 002088591-0001 8/2012
 IN 210894-0001 6/2007
 IN 210897-0001 6/2007
 IN 2768570001 2/2016
 JP D1326330 S 4/2008
 JP D1351277 S 2/2009
 JP D1456810 S 12/2012
 JP D1469635 S 5/2013
 JP D1478342 S 9/2013
 JP 1548987 S 5/2016

JP 1563161 S 11/2016
 JP 1574816 S 4/2017
 JP D1600999 S 4/2018
 KR 3006068280 7/2011
 KR 300849814 4/2016
 KR 300902453 9/2017
 RU 85816 7/2013
 RU 89999 U1 9/2014
 RU 90363 U1 10/2014
 RU 104650 U1 8/2017
 TW D149042 S 9/2012
 TW D169484 S 8/2015
 TW D172231 S 12/2015
 WO WO-DM080555 S 2/2013

OTHER PUBLICATIONS

Apple iPhone 5 pictures, as posted at GsmArena.com [online], [retrieved on Apr. 27, 2017]. Available on the Internet, (URL: http://www.gsmarena.com/apple_iphone_5-pictures-4910.php#image15), accessed on Sep. 2012.

Apple iPhone 7 is here with a water resistant body, better cameras, 256GB capacity & no headphone jack, posted Sep. 8, 2016, [retrieved Aug. 28, 2017]. Retrieved from Internet, (URL: <https://collinsdail.blogspot.com/2016/09/apple-iphone-7-is-here-with-water.html>).

Apple iPhone 7 and 7plus | New Camera, posted Sep. 8, 2016, [retrieved Aug. 28, 2017]. Retrieved from Internet, (URL: <http://sujoyrdas.blogspot.com/2016/09/apple-iphone-7-and-7plus-new-camera.html>).

Brownlee, Marques, "Apple iPhone X Unboxing!" Youtube.com, Oct. 31, 2017, Available at (<https://youtu.be/ODoQYGZt8M?t=68>).

Carlson, Ronald, Tapscape.com, "Translucent iPhone: Will Apple Revisit G3 iMac?," accessed at <http://www.tapscape.com/translucent-iphone/>, accessed on Apr. 3, 2013, 3 pages.

ConceptsiPhone, "iPhone 8 and iPhone 8 Plus—Introducing" Youtube, Oct. 7, 2016, accessed at (<https://www.youtube.com/watch?v=WSf8aJYCjg>).

Cultofandroid, "This Android-Powered iPhone 5C Clone Will Cost Just \$100 In China" accessed at http://www.cultofandroid.com/40408/this-android-powered-iphone-5c-clone-will-cost-just-100-in-china/?utm_campaign=twitter&utm_medium=twitter&utm_source=twitter, accessed on Aug. 27, 2013, 2 pages.

Daily Life News, "iPhone 5s Leaked Images Hint 2 Different Screen Sizes." accessed at <https://www.youtube.com/watch?v=8tcTHa63WHI>, accessed on Apr. 10, 2013, 4 pages.

Engadget, "Meizu's M8? Apple lawyers, start your engines", accessed at <http://www.engadget.com/2007/01/29/meizus-m8-apple-lawyers-start-your-engines/>, accessed on Jan. 29, 2007, 3 pages.

Everythingapplepro, "The 2018 iPhone X Plus Will be Big!" Youtube.com, [retrieved on Feb. 12, 2018], Retrieved from the Internet: (<https://youtu.be/m2iMjpAkTeQ?t=14>).

Faulkner, Cameron, "Essential Phone Review", Tech Radar, [retrieved on Nov. 25, 2017], 2017, accessed at Retrieved from the Internet: (URL: <http://www.techradar.com/reviews/essential-phone>).

Gokey, M., "LG G3 vs. HTC One M8: Which Android Flag Should iPhone Haters Fly?," published Sep. 18, 2014, accessed at www.digitaltrends.com/mobile/lg-g3-vs-htc-one-m8/, 12 pages.

Gorsler, Fabian, "Leak Suggests Apple Will Release 3 New iPhone Models in 2018" Highsnobiety.com, [retrieved on Nov. 14, 2017], Retrieved from the Internet: (<https://www.highsnobiety.com/2017/11/14/three-new-iphones-2018/>).

Gsmarena, "Nokia Lumia 820", accessed at http://www.gsmarena.com/nokia_lumia_820-4968.php, accessed on Aug. 29, 2013, 2 pages.

Gsmarena, "Xiaomi MI-2", accessed at http://www.gsmarena.com/xiaomi_mi_2-4928.php, accessed on Aug. 29, 2013, 2 pages.

Gsmarena, "Xiaomi MI-2s", accessed at http://www.gsmarena.com/xiaomi_mi_2s-5397.php, accessed on Aug. 29, 2013, 2 pages.

Hands-On With an iPhone 8 Dummy Model, posted Aug. 10, 2017, [retrieved Aug. 28, 2017]. Retrieved from Internet, (URL: <https://www.youtube.com/watch?v=YuQUBhOAbUM>).

Identify your iPhone Model, Retrieved from the Internet URL: <https://support.apple.com/en-us/HT201296>.

"iPhone 6, Une Enieme Maquette Comparee Avec L'iPhone 5s," published May 3, 2014, accessed at <http://www.nowhereelse.fr/iphone-6-maquette-comparee-iphone-5s-97315/>, 2 pages.

K11 Bumper vs. RhinoShield Crash Guard: Super Thin Protective Bumpers for iPhone 6s Plus!, posted Feb. 23, 2016, [retrieved Jan. 26, 2018]. Retrieved from Internet, <url:<https://www.youtube.com/watch?v=eX5ETZkOhj4>>, 3 pages.</url:<a>

Karmakar, Amit, "The iPhone X plus 2018 Dummy model and leaks" Youtube.com, [retrieved on Dec. 1, 2017], Retrieved from the Internet: (<https://www.youtube.com/watch?v=1pEesxpiOd4>).

MacManus, Christopher, cnet.com, "Artist pictures a budget iPhone—in color." accessed at <http://www.cnet.com/au/news/artist-pictures-a-budget-iphone-in-color/>, accessed at Mar. 21, 2013, 4 pages.

Maggio, Edoardo, "These renders show what Apple might have planned for the successor to the iPhone X" BusinessInsider.com, [retrieved on Jan. 24, 2018], Retrieved from the Internet: (<https://www.businessinsider.com.au/martin-hajek-renders-apple-2018-iphone-x-successor-2018-1?r=US&IR=T>).

Mayo, B., "Purported iPhone 6 Pictures Show Protruding Camera, Rounded Edges," 9to5Mac.com, accessed at <http://9to5mac.com/2014/03/31/purported-iphone-6-pictures-show-protruding-camera-rounded-edges/>, 23 pages.

Mia P., "Apple Leak Reveals All Glass Phone With 3D Sensor; Touch Bar Feature Redefines Emoji Use; Is This iPhone 8?" GameNGuide, Oct. 31, 2016, accessed at (<http://www.gamenguide.com/articles/60727/20161031/apple-leak-reveals-all-glass-phone-with-3d-sensor-touch-bar-feature-redefines-emoji-use-is-this-iphone-8.htm>).

Nokia, "Nokia Lumia 820—Our most versatile Lumia", accessed at <http://www.nokia.com/global/products/phone/lumia820/>, accessed on Aug. 29, 2013, 6 pages.

@NowhereElseFr, "Just Another Purported #iPhone6 or #iPhoneAir Dummy . . . #Apple." published May 4, 2014, accessed at <https://twitter.com/NowhereElseFr/status/462938116924264448/photo/1>, 5 pages.

@Onleaks, "#iPhone X!!! Yes, time has already come to meet the new #iPhone . . ." dated Jan. 6, 2019, accessed at <https://twitter.com/Onleaks/status/1081902300434780161>, 5 pages.

Photo-John, "Apple's iPhone 5 Camera—What's New?", as archived at <https://web.archive.org/web/20140805181048/http://www.photographyreview.com/reviews/apple-iphone-5-camera-whats-new>, published Sep. 12, 2012, 3 pages.

Schroeder, S., "Sharp Aquos S2 is a Nearly Bezel-Less Phone with Mid-Range Specs," Mashable, Aug. 8, 2017, Retrieved from the Internet: (URL: <http://mashable.com/2017/08/08/sharp-aquos-s2/#C05q3N0tzOqV>), 10 Pages.

"Sharp Executive Confirms iPhone 8 to Use OLED Display; Limited to Only Premium 5.5-inch Plus Model" Oct. 29, 2016, accessed at (<http://www.redsn0w.us/2016/10/sharp-executive-confirms-iphone-8-to.html>).

Stuff Staff in News, stuffideast.com "Apple's new iPhone to come in a five colours." accessed at <http://stuffideast.com/2013/04/11/151344/apples-new-iphone-to-come-in-a-five-colours/>, accessed on Apr. 11, 2013, 1 page.

stuff.tv, "Sparse wallets rejoice, the plastic budget iPhone 5S cometh, The iPhone 5S may not be an incremental increase but a decrease, in price and build quality." accessed at <http://www.stuff>

tv/news/sparse-wallets-rejoice-plastic-budget-iphone-5s-cometh, accessed on Mar. 23, 2013, 1 page.

Swift, "BBK Vivo Xplay X510W Review," published Oct. 21, 2013, accessed at <http://chinesetech.net/2013/10/21/bbk-vivo-xplay-x510w-review/>, 12 pages.

Team Digit, "Exclusive: First look at 2019 Apple iPhone XI renders," [retrieved on Jan. 6, 2019]. Retrieved from the Internet: (<https://www.digit.in/news/mobile-phones/exclusive-first-look-at-2019-iphone-xi-renders-45655.html>), 3 pages.

TechDesigns, "iPhone 8 Official 2017—Concept" Youtube, Oct. 27, 2016, accessed at (<https://www.youtube.com/watch?v=LYUJYLD1XR0>).

Verykool Spark LTE SL5011 review: All that glitters is not gold, posted May 24, 2016, [retrieved on Sep. 30, 2018]. Retrieved from Internet, (URL:<https://www.androidguys.com/reviews/verykool-spark-lte-sl5011-review-all-that-glitters-is-not-gold/>).

welectronics.com, "Xiaomi MI 2 GSM unlocked," accessed at <http://www.welectronics.com/gsm/misc/XIAOMI-MI-2.HTML?gclid=CK7Nr9bv-rYCFYOo4AodZ0EAEW>, accessed at Aug. 29, 2013, 2 pages.

Wu, Debbie, "All three iPhone 8 models to have glass backs" Nikkei Asian Review, Oct. 26, 2016, accessed at (<https://asia.nikkei.com/Business/Companies/All-three-iPhone-8-models-to-have-glass-backs?page=1>).

* cited by examiner

Primary Examiner — Ramzi Almatrahi

Assistant Examiner — Charles Cunningham

(74) *Attorney, Agent, or Firm* — Sterne, Kessler, Goldstein & Fox P.L.L.C.

(57)

CLAIM

The ornamental design for an electronic device, as shown.

DESCRIPTION

FIG. 1 is a bottom and front isometric view of an electronic device showing the claimed design;

FIG. 2 is a top and rear isometric view thereof;

FIG. 3 is a front elevation view thereof;

FIG. 4 is a rear elevation view thereof;

FIG. 5 is a left side elevation view thereof;

FIG. 6 is a right side elevation view thereof;

FIG. 7 is a top plan view thereof; and,

FIG. 8 is a bottom plan view thereof.

1 Claim, 6 Drawing Sheets

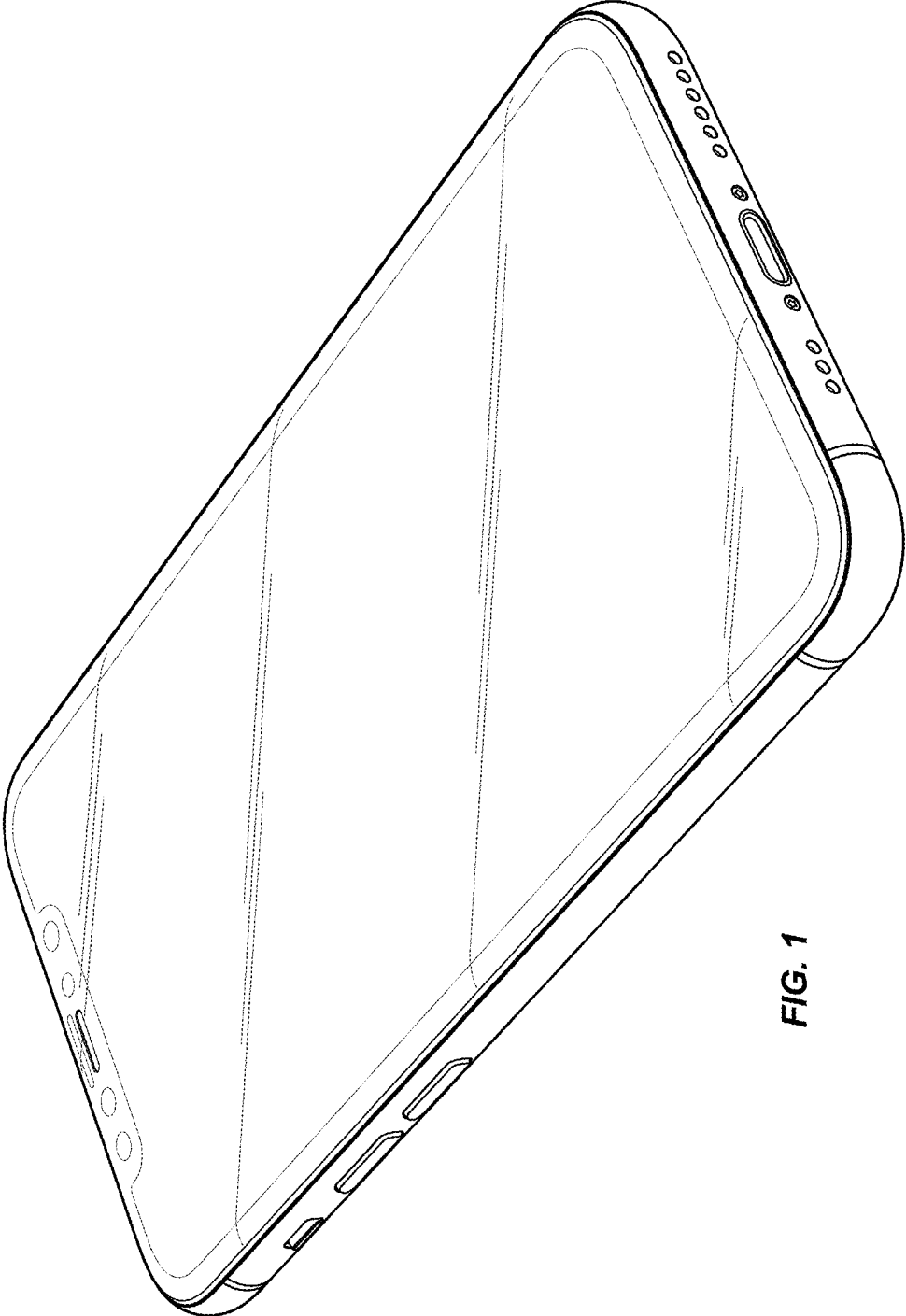

FIG. 1

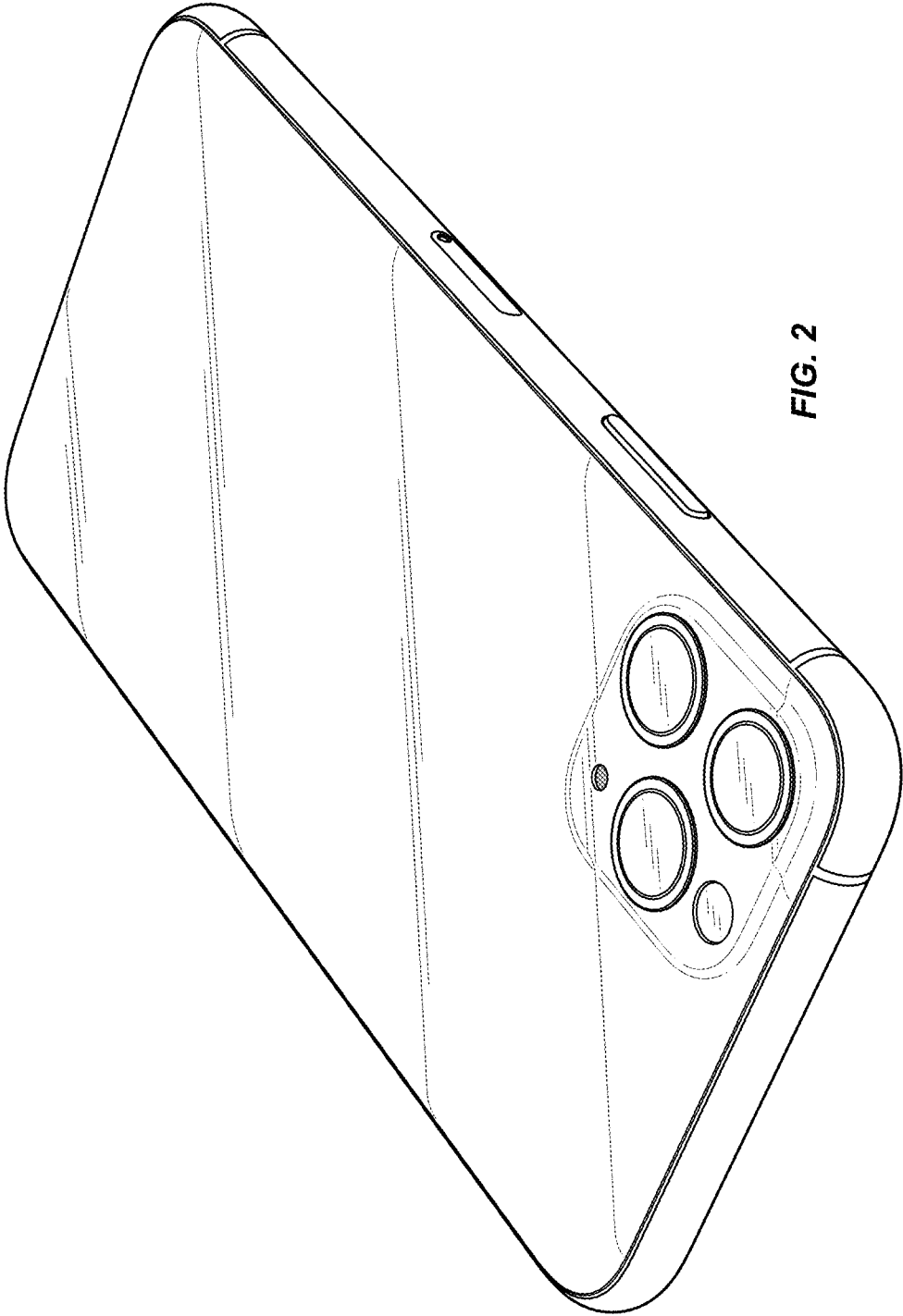

FIG. 2

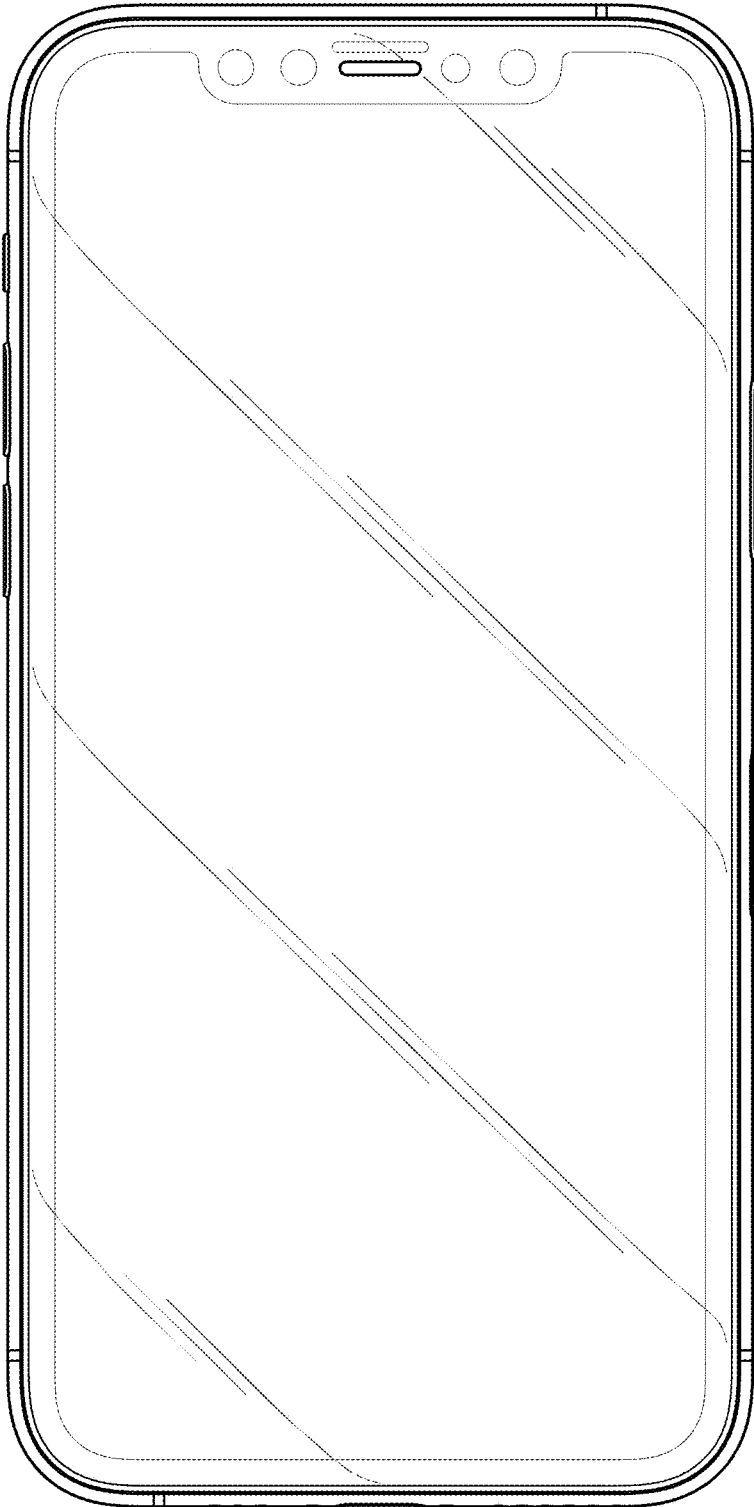

FIG. 3

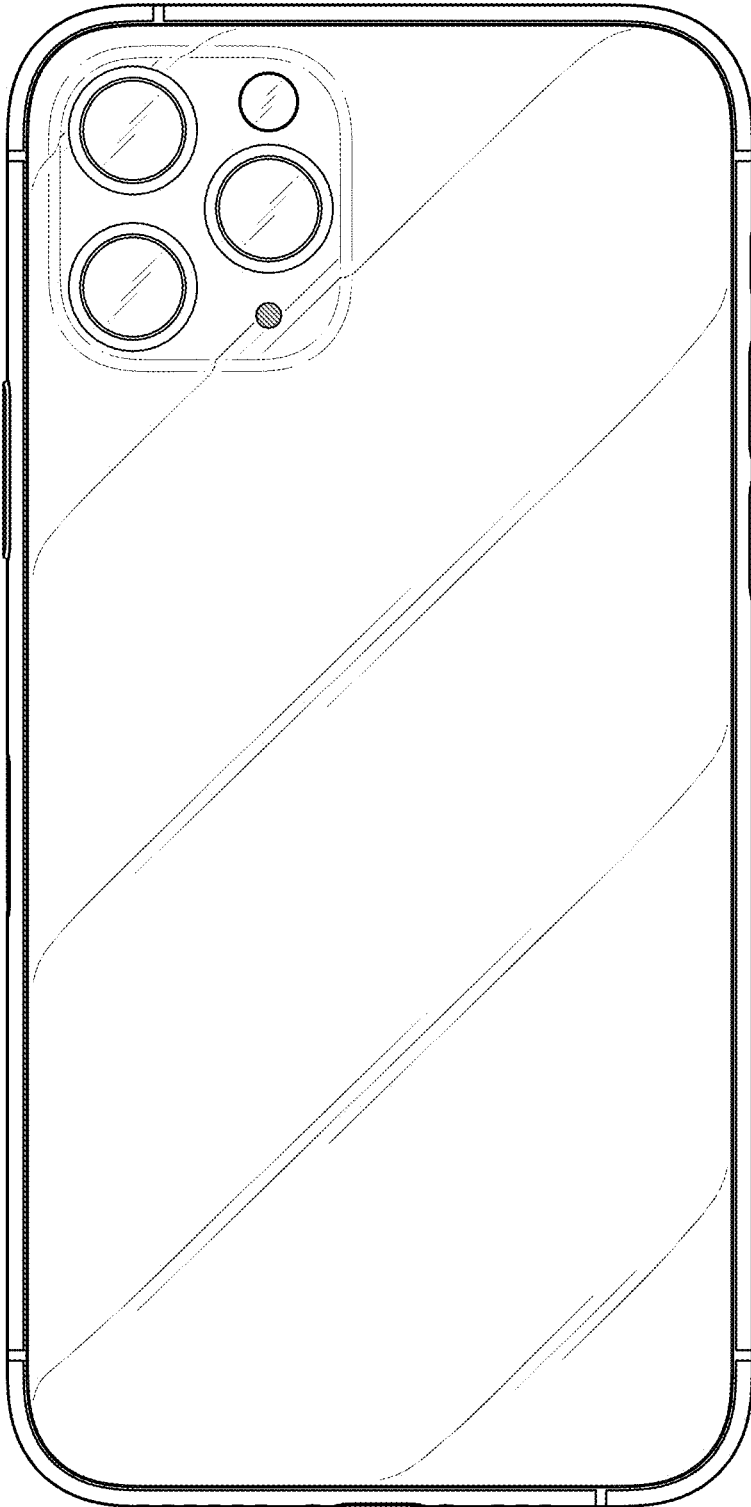

FIG. 4

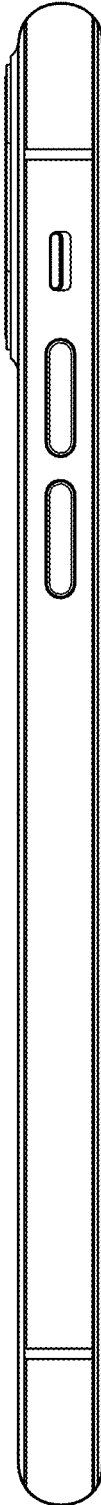

FIG. 5

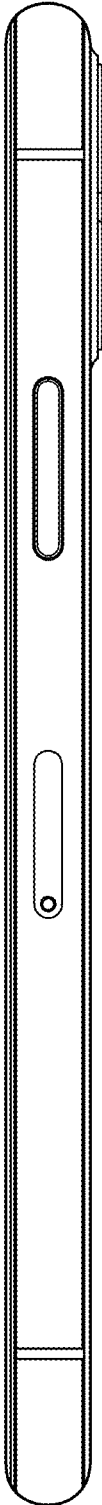

FIG. 6



FIG. 7

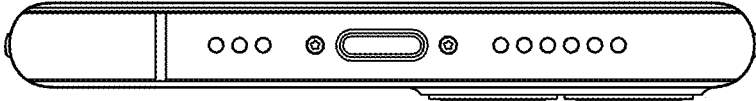

FIG. 8