

No. 689,257.

Patented Dec. 17, 1901.

G. WALTER.  
MIDDINGS PURIFIER.

(Application filed June 25, 1900.)

(No Model.)

3 Sheets—Sheet 1.

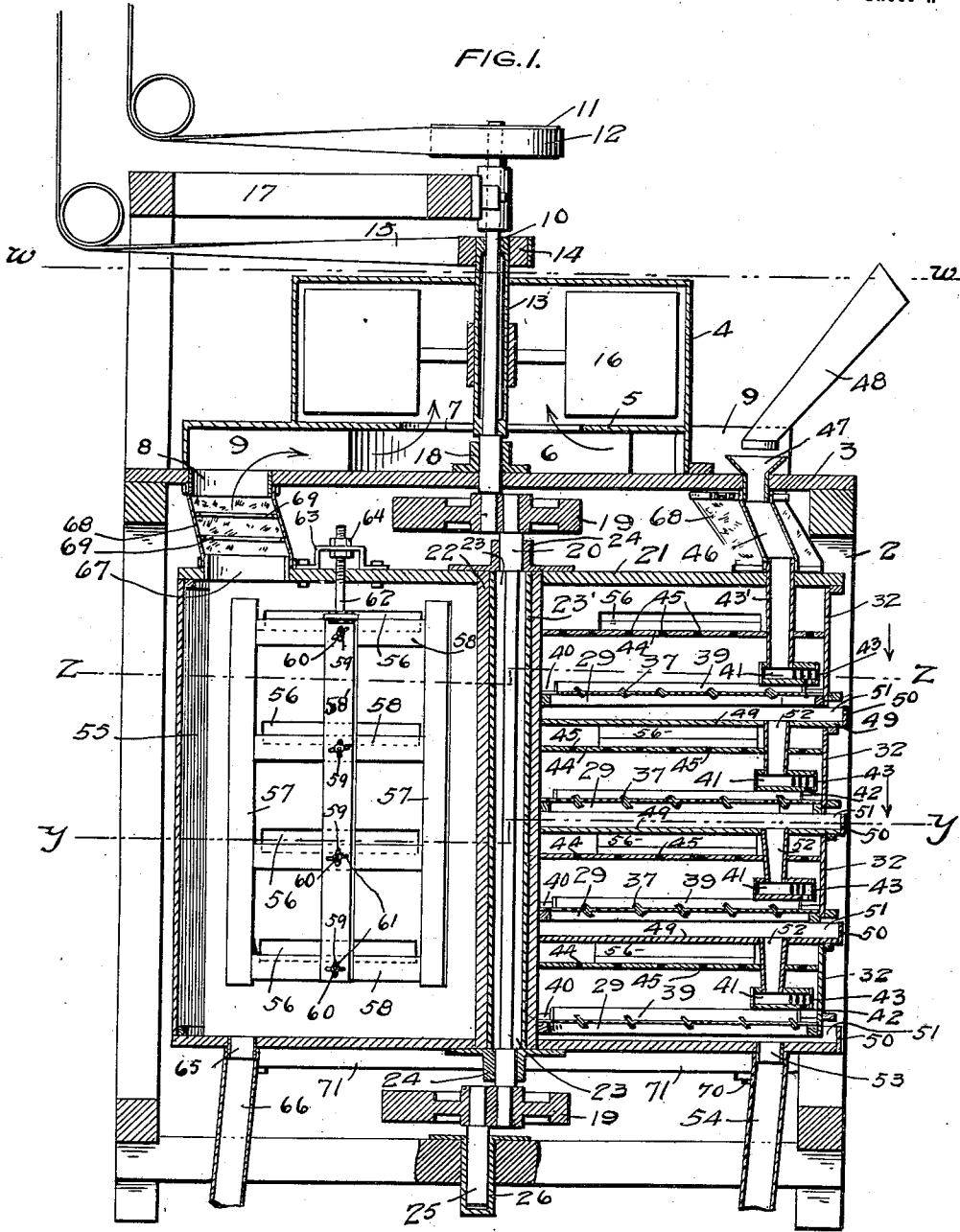

WITNESSES

*E. Stauss*  
*Richard Paul*

INVENTOR  
GEORGE WALTER

BY *Paul Hawley*  
HIS ATTORNEYS

G. WALTER.  
MIDLINGS PURIFIER.

(Application filed June 25, 1900.)

(No Model.)

3 Sheets—Sheet 2.

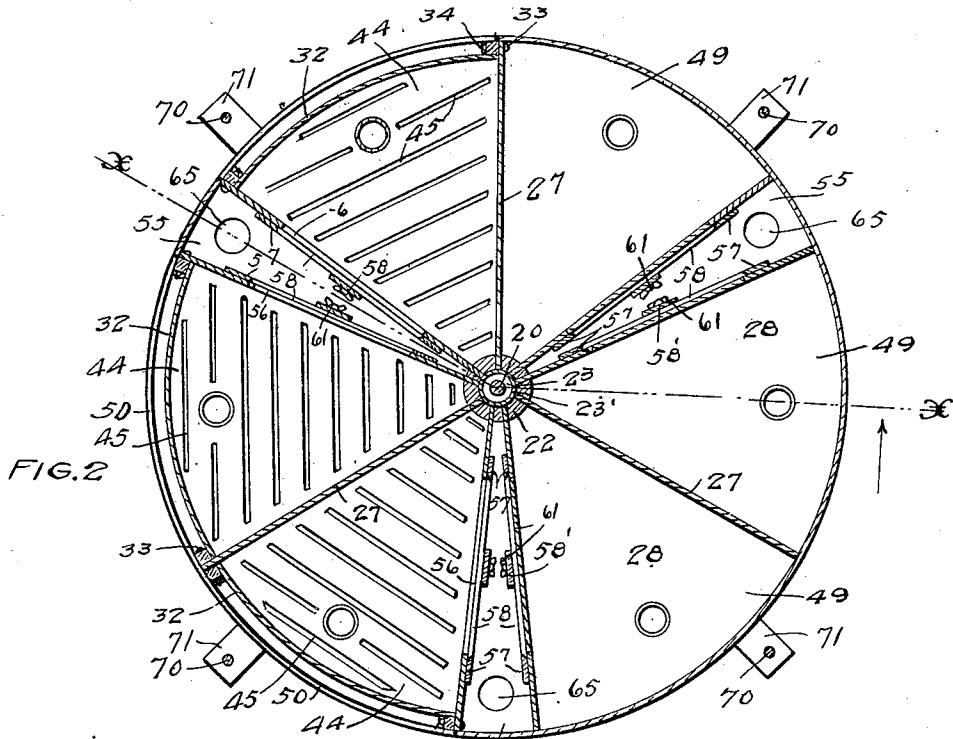

FIG. 2

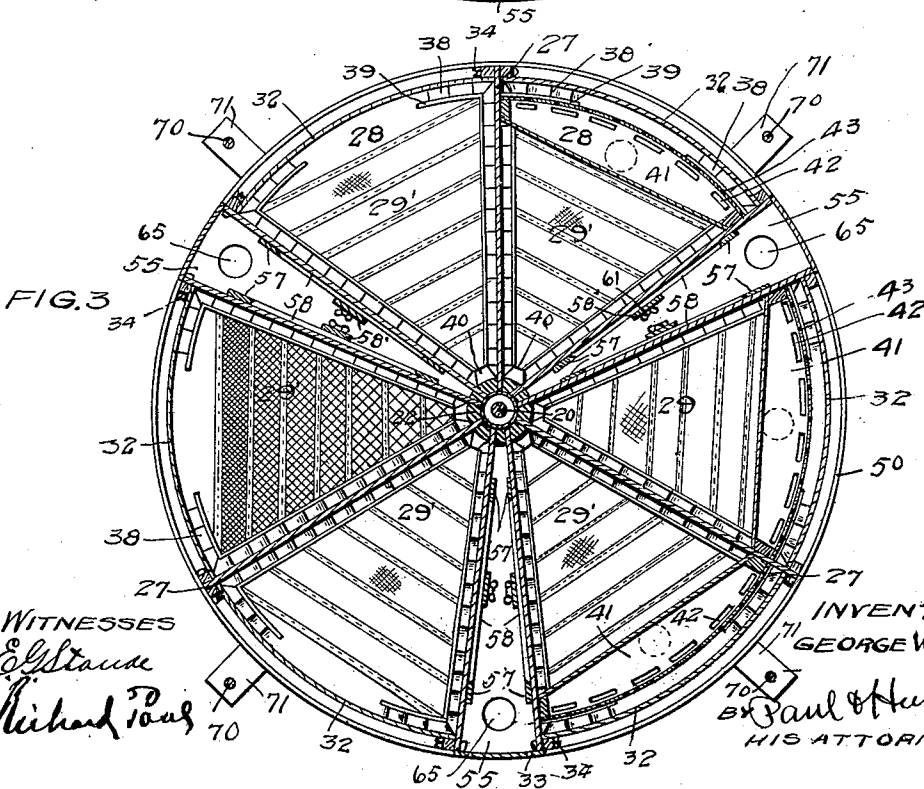

FIG. 3

WITNESSES  
*E. J. Stange*  
*Richard Paul*

INVENTOR  
 GEORGE WALTER  
 BY *Paul & Harvey*  
 HIS ATTORNEYS

G. WALTER.  
MIDLINGS PURIFIER.

(Application filed June 25, 1900.)

(No Model.)

3 Sheets—Sheet 3.

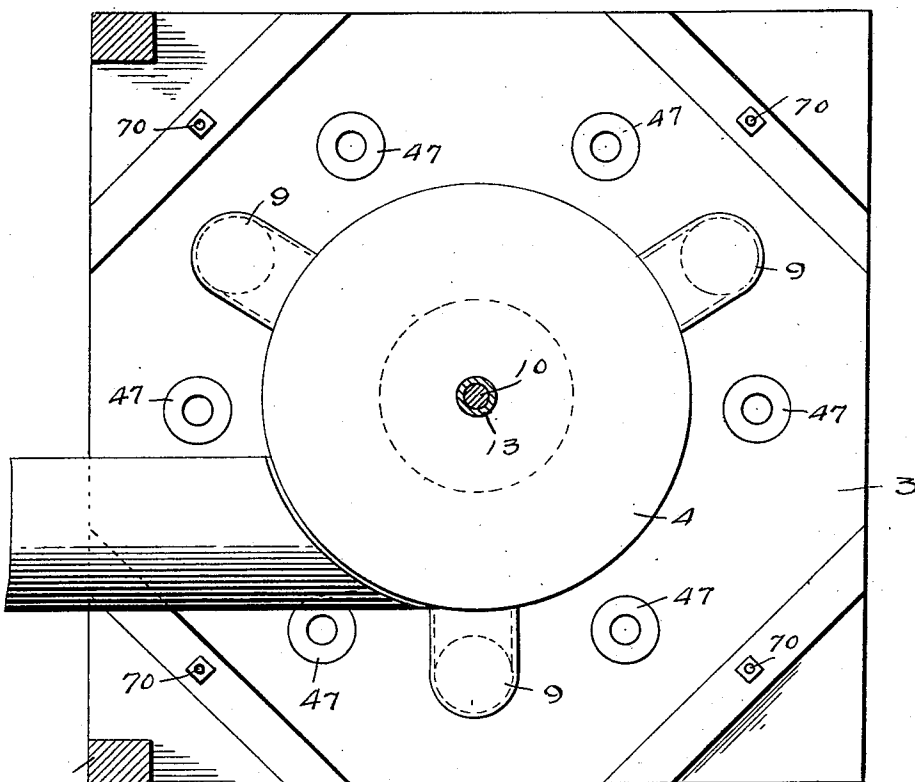
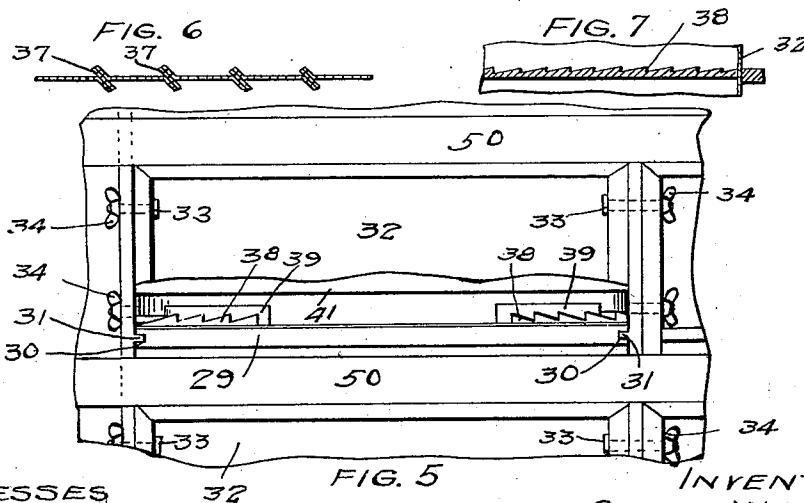

FIG. 4



WITNESSES  
*E. J. Struss*  
*Richard Deuel*

INVENTOR  
GEORGE WALTER  
By *Paul & Hawley*  
HIS ATTORNEYS

# UNITED STATES PATENT OFFICE.

GEORGE WALTER, OF MARYSVILLE, KANSAS.

## MIDLINGS-PURIFIER.

SPECIFICATION forming part of Letters Patent No. 689,257, dated December 17, 1901.

Application filed June 25, 1900. Serial No. 21,448. (No model.)

*To all whom it may concern:*

Be it known that I, GEORGE WALTER, of Marysville, county of Marshall, State of Kansas, have invented certain new and useful Improvements in Middlings-Purifiers, of which the following is a specification.

The invention relates to middlings-purifiers.

The object of the invention is to provide a machine wherein middlings-stock may be placed and the dust, bran, and coarse material separated therefrom.

A further object is to provide means for separating the fine floating dust from the heavier coarser particles after the same has been taken out of the middlings-stock.

A further object is to provide a purifier wherein different grades of stock may be cleaned simultaneously without mixing.

A further object is to provide a machine that is easily operated, of large capacity, and one that will quickly and effectually clean the middlings of all impurities.

The invention consists generally in a swinging or gyrating casing divided by partitions into compartments or chambers and radial air-trunks through which and said compartments ascending currents of air may be maintained.

Further, the invention consists in improved means for regulating the currents of air through said compartments.

Further, the invention consists in improved means for feeding or delivering the middlings-stock upon the sieves.

Further, the invention consists in providing means for preventing the meshes of the sieves from clogging.

Further, the invention consists in various constructions and combinations, all as hereinafter described, and particularly pointed out in the claims.

In the accompanying drawings, forming part of this specification, Figure 1 is a vertical section on the line  $xx$  of Fig. 2. Fig. 2 is a horizontal section on the line  $yy$  of Fig. 1. Fig. 3 is a similar view on the line  $zz$  of Fig. 1. Fig. 4 is a horizontal section on the line  $ww$  of Fig. 1. Fig. 5 is a detail showing the manner of supporting the sieves in the purifier-casing, and Figs. 6 and 7 are details of the sieves.

In the drawings, 2 represents a frame wherein the purifier-casing is supported. A floor or platform 3 is provided on the frame 2, and a fan-casing 4 is arranged upon said platform, said fan-casing being divided by a horizontal partition into two compartments, the lower of which forms a dust-settling chamber 6, that is connected with the upper portion of the casing through a large opening 7 and with openings 8 at intervals in the floor 3 by short air-trunks 9. A shaft 10 extends vertically through said fan-casing and is provided at its upper end with a pulley 11 and belt 12, that is connected to a suitable source of power. A sleeve 13 is arranged on said shaft and provided with a pulley 14, over which passes a belt 15. A fan 16 is arranged on said sleeve within the fan-casing, and said sleeve being loose on the shaft permits the fan to be driven at a higher speed than the shaft from which the purifier is operated.

The frame of the machine on one side extends above the floor 3 and is provided with a brace 17 near the upper end of said shaft to support and stay the same against lateral movement. A bearing-block 18 is provided on the floor 3 near the lower end of the shaft 10, and said shaft is adapted to extend down through said floor and is provided at its lower end with a heavy counterbalance-wheel 19, on which a shaft 20 is eccentrically mounted.

21 represents the casing of the swinging or gyrating purifier. This casing may be either round or polygonal, as preferred, and is preferably provided with a central stud or hub 22, having a longitudinal opening 23 to receive the metal tube 23', and a shaft 20, which passes through journal-boxes 24 provided at the top and bottom of the casing, as shown in Fig. 1. The lower end of the shaft 20 extends below the journal or bearing box 24 and is preferably mounted in a counterbalance-wheel corresponding to the one heretofore described and which is in turn eccentrically mounted on a short stud 25, mounted in bearings 26 on a cross-bar at the bottom of the frame 2.

The interior of the casing 21 is divided by vertical partitions 27 into a series of independent compartments 28, and, as shown in Figs. 2 and 3, I prefer to provide six of these compartments, though there may be a greater or less number, according to the diameter of

the casing and the size of the sieves to be used. When a circular form of casing is used, the sieve-frames are triangular in form, corresponding to a sector of a circle; but if the casing is polygonal in form the sieve-frames may be of any desired shape to adapt them to the compartments in which they are used.

29 represents one of the sieve-frames, which is preferably provided with slots 30 in its sides to receive ribs 31 on the partition-wall and whereon the frame is slidable. There may be any desired number of sieves in each compartment according to the height of the machine and the condition of the material to be cleaned; but in the drawings I have shown the purifier provided with four sieves in each compartment. At the outer ends of the sieves are removable panels 32, that are normally held in place by bolts 33 and thumb-screws 34. The sieve-frames being slidable on their supports within the compartments may be easily and quickly taken out or inserted by removing these panels. This construction permits any of the sieves to be removed for the purpose of cleaning or repairing the same or for substituting those of different mesh or when it is desired to operate the machine with a less number. Each sieve is preferably composed of a series of narrow strips of silk cloth or other suitable sieve material 29', preferably four or five inches in width, arranged transversely in the frames, and these strips may be of different degrees of mesh according to the material to be passed through them, the outer strips being finer, preferably, than those near the center of the machine. (See Fig. 3.) Between these narrow strips I prefer to arrange at an incline a series of narrow comparatively stiff strips or tapes 37, extending transversely of the sieves and forming, with the edges of the sieve-strips, ribs or projections which serve to advance the material toward the inner ends of the sieves. These projections will also serve to prevent the material from dancing around on the sieves and will cause it to spread out in even sheets and advance uniformly over the same. The number of sieves used in each compartment will depend largely upon the condition of the material to be cleaned. In coarse middlings the difference in weight between dust and bran and the purified stock is greater than in fine middlings. Consequently a larger number of sieves may be employed in those compartments used for cleaning coarse than for those for cleaning fine middlings. In fine middlings the weight of the dust and purified stock is nearly the same. Therefore I prefer to provide a larger space between the sieves and the perforated plates in the compartments used for cleaning fine middlings to allow room for the middlings to settle and prevent their being carried away by the air-current. I am thus able to effect a very complete separation of any grade of stock.

I prefer to provide a series of steps or serrations 38 in the sides and a portion of the

outer ends of the sieve-frames, and between said steps, and the middle portion of the sieves I provide ribs 39, having openings 40 between their inner ends, communicating with the passage-ways formed by said ribs in the partition-walls. I prefer to extend the ribs around the ends of the frames, leaving openings through which the cleaning material may pass onto the sieves. When the stock is fed into the machine, a quantity of corn, beans, wheat, or similar material is mixed with it and, falling upon the sieves, cleans the meshes of the same as the stock is advanced toward the center of the machine. As the machine is operated the corn, beans, or like material collects at the inner ends of the sieves and enters the passages formed by the ribs 39 and the partition-walls and is advanced by the corrugated floors of the same back to the outer or receiving ends of the sieves, where it is discharged onto the meshes of the sieves again and is moved over the same as before. The corn or beans being heavier than the middlings stock will lie close to the meshes of the sieves and will thoroughly clean the same and will be kept in motion back and forth over the sieves as the machine is gyrated. The sieves are thus easily cleaned and prevented from clogging without the necessity of removing them and without any delay in the operation of the machine.

Above each sieve, near the outer end of the same, I prefer to provide a receiving-chamber or feed-receptacle 41, provided in its floor with a series of discharge-slots 42 and overflow openings or slots 43 in its outer wall. These feed chambers or receptacles extend, preferably, across the sieves and receive the middlings-stock from feed-spouts located above them. The upper feed-spout 43 of the series extends up through a plate 44, provided with slots 45, and through the top of the casing and communicates with a spout 46 and a hopper 47, provided on the floor 3 and adapted to receive the middlings-stock from a delivery or feed pipe 48. As the material flows down into the receiving-chamber it falls through the slots 42 upon the outer ends of the sieves and is advanced over the same by the motion of the machine, and said chamber extending entirely across the sieves insures the even distribution of the material thereon. If the holes in the floor of the feed-chamber become clogged and the chamber fills up with the middlings stock, the surplus material will be discharged through the overflow-slots 43, provided in the wall of the chamber, and will fall upon the head of the sieve beneath and mingle with the material that falls through the holes or slots 42.

In each compartment beneath the upper sieve of the series I prefer to provide gathering-boards 49, that project beyond the panels at the outer ends of the sieves and are provided with curved strips 50, arranged to partially close the openings 51 between said boards and the panels immediately above the

same. These openings 51 form passages through which air is admitted to the space beneath the sieves. Beneath each gathering-board are plates corresponding to the plate 5 44, heretofore described, having slots 45, through which the dust and other foreign material gathered up by the air-currents are lifted and conveyed to the air-trunks hereinafter described.

10 Beneath each sieve of the series I prefer to provide a vertical spout 52, having its upper end flush with the top of the gathering-board and supported thereby and its lower end fitting within an opening in the top of the receiving-chamber and adapted to convey the material thereto. The construction and alternate arrangement of the sieves, gathering-boards, and perforated floors are carried out 15 from the top to the bottom of the casing, at which latter point a discharge-opening 53 is provided beneath the lower sieve of the series communicating with a discharge-spout 54.

The air-trunks which I have provided in this machine for receiving the dust and other 25 foreign material separated from the middlings by the air-currents are preferably radial in form, are designated by reference-figures 55, and are arranged between the alternate pairs of compartments, so that there is a dust-collecting chamber or air-trunk for each pair of 30 compartments. The side walls of these air-trunks are provided with a series of horizontal slots or openings 56, arranged at intervals therein, each slot or opening communicating 35 with the space above the slotted plates in the adjoining compartment. Upon the partition-walls at the ends of the slots I provide slats or bars 57, forming guides for the short slats 58, that are adapted to slide between them 40 over the openings 56. The slats 58 are preferably connected by a bar 58', provided with short slots 59 to receive bolts 60 on said slats, which are rendered adjustable therein by means of thumb-screws 61. The slats 58 being adjustable on the bar 58' independently 45 of each other, it is obvious that the size of the openings leading from the air-trunk to the several compartments may be regulated according to the condition of the material that is to be cleaned. As the fine material only is separated 50 from the middlings in the upper part of the machine and as the air-current is somewhat stronger at that point, the upper slats of the series will be adjusted to leave a smaller opening between the air-trunk and the compartments 55 than at the lower part of the machine, where the coarser heavier foreign material is removed from the middlings and the air-current is weaker. Instead of providing an air-trunk for each pair of compartments I may 60 divide the trunks vertically, so that there will be one for each compartment. In this case I provide a discharge-opening in the bottom of each subdivision of the air-trunks, so that the 65 dust coming from each compartment will not be mingled with the dust from the other com-

partments, as it frequently happens that the dust from one compartment or section of the chamber is of better quality than from another.

In order that the operator may adjust the 70 slats when the machine is in motion, I prefer to provide a threaded bolt 62 at the upper end of the bar 58', said bolt extending up through the top of the casing and secured to a bracket 75 63 by lock-nuts 64. In the bottom of each air-trunk I prefer to provide discharge-openings 65, leading to spouts 66, through which the heavier and coarser foreign material which will settle to the bottom of the air-trunk may be discharged out of the machine. 80 The top of each air-trunk is provided with large openings 67, connected with the openings 8 by flexible spout connection 68, and within these hoods or spout connections 68 85 I prefer to arrange rings or hoops 69 to prevent the flexible connections 68 from contracting and shutting off the air-currents.

Any suitable means may be provided for 90 suspending the gyrating casing within the frame of the machine; but I prefer rods 70, secured at their upper ends in the top of the frame and at their lower ends to lugs or brackets 71, provided on the bottom of the casing. I have shown in Fig. 1 but one feed- 95 spout for delivering material to the machine; but it will be understood that I may provide an independent spout for each compartment, so that at any time the operator may feed different grades of stock into the machine and 100 clean them independently.

The operation of the machine is as follows: The operator having adjusted the air-regulating devices within the air-trunks starts 105 the machine and permits the stock to flow into the receiving-chambers, from whence it will be delivered in a uniform sheet upon the outer ends of the sieves. The swinging or gyrating motion of the machine will advance the material toward the inner or tail end of each 110 sieve, and the transverse strips will prevent the material from dancing around on the sieve and will aid in advancing it toward the center of the machine. The air-current above the top sieves will be stronger than 115 above the others, and consequently the upper air-regulating devices will be adjusted so that there will be less space or opening between the air-trunks and the spaces above 120 the top sieves. As the air-current grows weaker toward the bottom of the machine the lower air-regulating devices will be adjusted to leave larger openings between the air-trunks and the compartments. At any time 125 while the machine is in motion the operator may adjust the air-regulating devices by means of the bolt and lock-nuts on the top of the casing. As the machine is operated currents of air will be established through the openings in the outer walls of the compart- 130 ments, up through the sieves and the material thereon, through the air-trunks, and up

into the fan-casing. The dust and fine particles will be lifted out of the stock as it passes through the upper sieves and a large quantity of it carried in suspension by the air-current up to the dust-settling chamber provided in the bottom of the fan-casing. In passing through the air-trunks the heavier particles will drop to the bottom and be discharged through the openings therein. As the middlings pass down through the sieves the coarser particles, the bran, and fibers will be separated from the pure stock and carried out into the air-trunks and deposited on the bottoms thereof, while the purified stock will pass through the lower sieves of the series and be discharged through the openings in the bottoms of the compartments. A very complete separation of the middlings stock is thus effected, and as many different grades may be cleaned at the same time as there are separate independent compartments in the machine. The currents of air passing vertically through the compartments will serve to clean the meshes of the sieves of dust or other foreign material that may lodge therein, so that the sieves can be kept clean without the necessity of removing them from the machine. By providing the vertical air-current I am able to use stationary sieves successfully and effect a thorough separation of the middlings stock and at the same time prevent the sieves from clogging.

I do not wish to confine myself to the particular arrangement of the sieves in the compartments or the position of the perforated floors and gathering-boards with respect thereto, nor to the particular construction of the receiving-chambers provided within the sieves, as the same may, with other details of construction, be modified considerably by any one skilled in the art without departing from my invention.

I have shown and described in this application certain parts of a middlings-purifier that are also shown in an earlier application, filed November 4, 1899, renewed October 17, 1901, Serial No. 79,028. The parts referred to are the construction of the fan-casing and the connection between the same and the gyrating casing of the purifier. These parts being described and claimed in the earlier application I make no claim to them herein.

Having thus described my invention, I claim as new and desire to secure by Letters Patent—

1. A middlings-purifier, comprising a swinging or gyrating casing divided into a series of compartments or chambers, a vertical series of sieves horizontally arranged in said compartments and between which a vertical series of horizontal air-trunks are formed, a horizontal series of vertical air-trunks provided between said compartments or chambers and communicating therewith, and means for maintaining ascending currents of air through said sieves and the material there-

on and through said horizontal and vertical air-trunks, substantially as described.

2. A middlings-purifier, comprising a swinging or gyrating casing divided by partitions into compartments, sieves provided in said compartments, radial air-trunks provided between said compartments and communicating therewith, and means for maintaining ascending currents of air through said compartments and said sieves and the material thereon and through said radial air-trunks, substantially as described.

3. A middlings-purifier, comprising a swinging or gyrating casing divided by partitions into a series of independent compartments, stationary sieves provided in said compartments, feed-spouts for delivering the material to be cleaned upon said sieves, radial air-trunks provided between the alternate pairs of compartments and communicating with said pairs respectively, and means for maintaining ascending currents of air through said compartments, through said sieves and the material thereon, and through said air-trunks, substantially as described.

4. A middlings-purifier, comprising a gyrating casing divided by partitions into a series of compartments, sieves provided in said compartments, feed-spouts for delivering material to said sieves, air-trunks provided between said compartments and communicating therewith, a suction-fan and suitable air trunks or passages connecting said fan with said air-trunks whereby currents of air will be maintained through said compartments and said sieves, the material thereon and through said air-trunks, substantially as described.

5. A middlings-purifier, comprising a swinging or gyrating casing divided by vertical partitions into a series of independent compartments, stationary sieves provided in said compartments, radial air-trunks provided between said sieves and communicating with said compartments, means for maintaining ascending currents of air through said compartments, said sieves and the material thereon and through said air-trunks, and means provided in said air-trunks for regulating the currents of air above each sieve independently of the currents above the remaining sieves, substantially as described.

6. A middlings-purifier, comprising a swinging or gyrating casing divided by vertical partitions into a series of compartments, sieves provided within said compartments, radial air-trunks provided between said compartments and having openings in their walls communicating with the spaces above said sieves, vertically-adjustable slats provided on the walls of said air-trunks whereby the currents of air over said sieves may be regulated, and a suction-fan device connected with said air-trunks adapted to maintain currents of air through said compartments and said air-trunks, substantially as described.

7. In a middlings-purifier, the combination, with a gyrating casing divided by partitions into independent compartments, stationary sieves provided within said compartments, radial air-trunks provided between said sieves having openings in their walls, and communicating with the said compartments, means for regulating the currents of air through the openings in the walls of said air-trunks, discharge-openings provided at the bottom of said air-trunks, and a suction-fan device connected with the tops of said air-trunks, substantially as described.

8. In a middlings-purifier, the combination, with a gyrating casing divided by partitions into independent compartments, sieves provided within said compartments, radial air-trunks provided between said compartments, said air-trunks having openings in their walls communicating with the spaces above said sieves, bars vertically adjustable on the walls of said air-trunks, the cross-slats adjustably secured to said bars and whereby the currents of air through the openings in the walls of said air-trunks may be regulated, and a suction-fan device connected with the tops of said air-trunks, substantially as described.

9. In a middlings-purifier, the combination, with a gyrating casing divided by partitions into compartments or chambers, stationary sieves arranged within said compartments, perforated plates or floors provided above said sieves, spouts wherefrom the material is delivered to said sieves, air-trunks provided between said compartments and having openings in their walls communicating with the space above said perforated floors, a suction-fan device connected with said air-trunks and adapted to establish ascending currents of air through said sieves, the material thereon and said floors and means for regulating the currents of air through the openings in the walls of said air-trunks, substantially as described.

10. In a middlings-purifier, the combination, with a gyrating casing divided by partitions into compartments or chambers, stationary sieves arranged within said compartments, delivering-spouts provided above said sieves, gathering-boards provided beneath said sieves to receive the material therefrom, air-inlet passages or ports provided in the walls of said casing between said gathering-boards and said sieves, ascending-air trunks provided between said compartments, said air-trunks having openings in their walls communicating with the space above said sieves, and a suction-fan device connected with said air-trunks and adapted to maintain currents of air through said sieves and said compartments, substantially as described.

11. In a gyrating middlings-purifier, a sieve composed of a series of strips of suitable sieve material transversely arranged in the sieve-frame, said strips gradually increasing in

coarseness of mesh from the head toward the tail of the sieve, and narrow comparatively stiff tapes or strips provided between the edges of the abutting strips and extending above the surface of the sieve, whereby the material is advanced toward the tail of the sieve by the motion of the machine.

12. A middlings-purifier, comprising a swinging or gyrating casing divided by partitions into a series of independent compartments or chambers, sieves provided in said compartments, air-trunks provided between said compartments or chambers and communicating therewith, dust-collecting chambers provided in the lower part of said air-trunks and means for maintaining ascending currents of air through said compartments and said sieves and the material thereon and through said air-trunks, substantially as described.

13. A middlings-purifier, comprising a swinging or gyrating casing, a series of sieves provided one above the other therein, ascending-air trunks provided between the sieve-frames, the walls of said trunks having openings communicating with the spaces above and below said sieves, and a suction-fan connected with said air-trunks.

14. A middlings-purifier, comprising a swinging or gyrating casing divided into a series of compartments or chambers, sieves provided in said compartments, independent ascending-air trunks provided between said compartments and said sieves and connected with the spaces above and below said sieves, and means connected with said air-trunks for maintaining ascending currents of air through said sieves and the material thereon, substantially as described.

15. A middlings-purifier, comprising a gyrating or swinging casing a series of stationary sieves provided within said casing, ascending-air trunks provided between and extending above and below the alternate pairs of sieves, the walls of said trunks having openings communicating with the spaces between said sieves, and a suction-fan device connected with said air-trunks and adapted to create ascending currents of air through said sieves and the material thereon, substantially as described.

16. A middlings-purifier, comprising a swinging or gyrating casing, a series of stationary sieves arranged one above the other therein, ascending-air trunks provided between the sieve-frames and extending to the wall of the casing and having openings in their walls communicating with the spaces above and below the several sieves of the series, a suction-fan device connected with said air-trunks and adapted to establish ascending currents of air through said sieves and the material thereon, and means for regulating the currents of air above said sieves, and through the openings in the walls of said air-trunks, substantially as described.

17. A middlings-purifier, comprising a circular gyrating casing, a series of sector-shaped sieves provided within said casing, ascending-air trunks provided between the alternate pairs of said sieves and having openings in their walls communicating with the spaces above and below the several sieves of the series, and a suction-fan device connected with said air-trunks and adapted to create ascending currents of air through said sieves and the material thereon, substantially as described.
18. A middlings-purifier, comprising a circular gyrating casing, a series of sieves arranged one above the other therein, ascending-air trunks arranged between the sieve-frames and having openings in their walls communicating with the spaces above and below the several sieves of the series, said trunks extending to the wall of the casing, whereby currents of air may be established transversely of said sieves, and a suction-fan connected with said air-trunks.
19. In a middlings-purifier, the combination, with a gyrating casing, of sieves arranged one above the other therein, receiving-chambers provided above the outer ends of said sieves, said chambers having holes in their floors or bottoms through which the material is fed in an even sheet upon the heads of the sieves, and feed-spouts between and alternating with said sieves and through which the material is conducted to said chambers, substantially as described.
20. In a middlings-purifier, the combination, with a gyrating casing, of a series of sieves arranged one above the other therein, receiving-chambers provided over the outer ends of said sieves and having discharge-openings in their floors through which the material is deposited in an even sheet upon said sieves, gathering-boards provided beneath said sieves, and feed-spouts leading from said gathering-boards to said receiving-chambers, substantially as described.
21. In a middlings-purifier, the combination, with a gyrating casing, of a sieve arranged within the same, a receiving-chamber 41 provided over the outer end of said sieve, said chamber having a series of discharge-openings 42 in its floor or bottom through which the material is fed in an even sheet upon the head of the sieve, overflow-openings 43 provided in the wall of said chamber through which the excess material fed thereto is discharged upon said sieve, a feed-spout 43', and a spout 46 connecting said spout 43' with a suitable delivery-pipe, substantially as described.
22. In a middlings-purifier, the combination, with a gyrating casing, of a sieve arranged therein, a receiving-chamber provided over the outer end of said sieve and having holes in its bottom through which the material is fed in an even sheet upon the head of the sieve, a feed-spout 43' through which the material is fed to said receiving-chamber, a slotted plate 44 through which said feed-spout 43' extends, an air-trunk connected with the space above said slotted floor, and a suction-fan connected with said air-trunk.
23. In a gyrating middlings-purifier, a sieve, in combination with a series of tapes arranged on edge transversely of said sieve and at intervals thereon, said tapes being inclined toward the tail of the sieve to aid in advancing the material over the same.
24. The combination, with a gyrating casing, of sieves arranged therein, radial air-trunks provided between the sieve-frames and extending to the wall of the casing and communicating with the spaces above and below said sieves, a fan-casing mounted on said gyrating casing, a fan provided therein, and a dust-collecting chamber in the lower part of said fan-casing and communicating with said fan and with each of said air-trunks, for the purpose specified.
25. A middlings-purifier, comprising a gyrating casing, a series of sieves arranged therein, vertical air-trunks provided between the sieve-frames and having openings in their walls communicating with the spaces above and below the several sieves of the series, dust-collecting chambers provided at the bottoms of said air-trunks, suitable discharge-spouts therefor, and a suction-fan device connected with the tops of said air-trunks and adapted to create currents of air through said sieves and the material thereon, substantially as described.
26. A middlings-purifier, comprising a swinging or gyrating casing, a series of sieves provided one above the other therein, air-trunks provided between the sieve-frames and having openings in their walls communicating with the spaces above and below the several sieves of the series, dust-collecting chambers for the heavier refuse material provided in the bottoms of said air-trunks, and a suction-fan device connected with the tops of said air-trunks and adapted to create currents of air through and across said sieves and through said air-trunks to separate the lighter particles of dust from the middlings, substantially as described.
27. In a gyrating middlings-purifier, a sieve, in combination, with a series of tapes arranged transversely at intervals thereon, said tapes being inclined toward the tail of the sieve and adapted to yield to the weight or pressure of the advancing material, for the purpose specified.
28. In a gyrating middlings-purifier, a sieve composed of a series of strips of suitable material, in combination, with tapes or strips provided between the edges of the sieve-strips and extending above the surface of the sieve and yieldingly inclined toward the tail of the same, whereby the movement of the material is accelerated over the surface of the sieve.

29. In a middlings-purifier, the combination, with a gyrating casing, of sieves provided therein, air-trunks communicating with the spaces above said sieves, a suction-fan, flexible spouts provided between said fan and said  
5 air-trunks, and hoops or rings provided within said spouts, said rings being independent of each other and of the spout connections, whereby contraction of the spouts is prevented and

a free gyrating movement permitted, substantially as described.

In witness whereof I have hereunto set my hand this 18th day of June, 1900.

GEORGE WALTER.

In presence of—  
W. W. REDMOND,  
P. G. WADHAM.