

(19) World Intellectual Property Organization
International Bureau



(43) International Publication Date
28 January 2010 (28.01.2010)

(10) International Publication Number
WO 2010/010437 A1

(51) International Patent Classification:
G01J 3/453 (2006.01)

(21) International Application Number:
PCT/IB2009/006282

(22) International Filing Date:
20 July 2009 (20.07.2009)

(25) Filing Language: English

(26) Publication Language: English

(30) Priority Data:
61/083,620 25 July 2008 (25.07.2008) US

(71) Applicants (for all designated States except US): **CENTRE NATIONAL DE LA RECHERCHE SCIENTIFIQUE - CNRS** [FR/FR]; 3 rue Michel-Ange, F-75794 Paris Cedex 16 (FR). **UNIVERSITE PARIS-SUD 11** [FR/FR]; Bâtiment 300, F-91405 Orsay Cedex (FR).

(72) Inventors; and

(75) Inventors/Applicants (for US only): **PICQUÉ, Nathalie** [FR/FR]; 11 Résidence des Quinconces, F-91190 Gif-sur-Yvette (FR). **GUELACHVILI, Guy** [FR/FR]; La Fontaine Pessée, 9 route de Saclas, F-91150 Etampes (FR). **MANDON, Julien** [FR/FR]; 71 rue de la Mutualité, F-92160 Antony (FR).

(74) Agent: **NOVAGRAAF IP**; 122 rue Edouard Vaillant, F-92593 Levallois-Perret Cedex (FR).

(81) Designated States (unless otherwise indicated, for every kind of national protection available): AE, AG, AL, AM, AO, AT, AU, AZ, BA, BB, BG, BH, BR, BW, BY, BZ, CA, CH, CL, CN, CO, CR, CU, CZ, DE, DK, DM, DO, DZ, EC, EE, EG, ES, FI, GB, GD, GE, GH, GM, GT, HN, HR, HU, ID, IL, IN, IS, JP, KE, KG, KM, KN, KP, KR, KZ, LA, LC, LK, LR, LS, LT, LU, LY, MA, MD, ME, MG, MK, MN, MW, MX, MY, MZ, NA, NG, NI, NO, NZ, OM, PE, PG, PH, PL, PT, RO, RS, RU, SC, SD, SE, SG, SK, SL, SM, ST, SV, SY, TJ, TM, TN, TR, TT, TZ, UA, UG, US, UZ, VC, VN, ZA, ZM, ZW.

(84) Designated States (unless otherwise indicated, for every kind of regional protection available): ARIPO (BW, GH, GM, KE, LS, MW, MZ, NA, SD, SL, SZ, TZ, UG, ZM, ZW), Eurasian (AM, AZ, BY, KG, KZ, MD, RU, TJ, TM), European (AT, BE, BG, CH, CY, CZ, DE, DK, EE, ES, FI, FR, GB, GR, HR, HU, IE, IS, IT, LT, LU, LV, MC, MK, MT, NL, NO, PL, PT, RO, SE, SI, SK, SM, TR), OAPI (BF, BJ, CF, CG, CI, CM, GA, GN, GQ, GW, ML, MR, NE, SN, TD, TG).

Published:

— with international search report (Art. 21(3))

(54) Title: **FOURIER TRANSFORM SPECTROMETER WITH A FREQUENCY COMB LIGHT SOURCE**

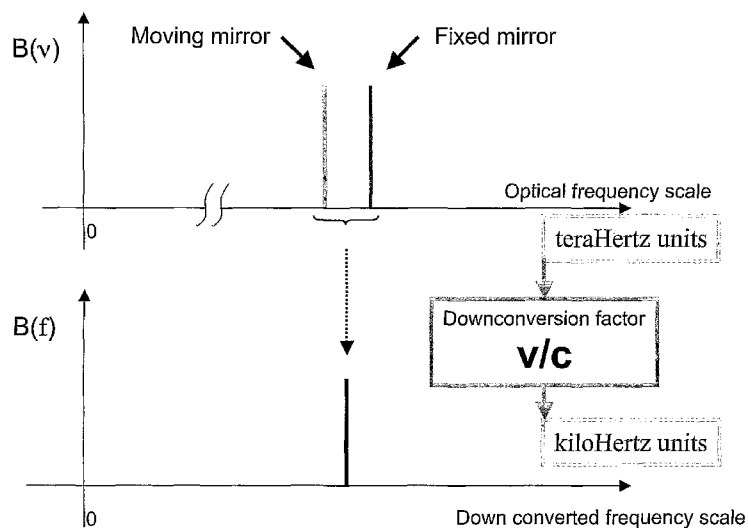

FIG. 1

(57) Abstract: The invention relates to a Fourier transform spectrometer (1) comprising: a coherent light source (2); an interferometer (4) adapted to separate the coherent light source into two or more parts in order to generate through frequency- or phase-induced effects, interferences between the two or more parts; detection means (5) adapted to detect the interferences, wherein the coherent light source comprises a frequency comb generator (2) having a frequency repetition rate, and the detection means are adapted to detect the beating of pairs of frequencies of the frequency comb separated by the frequency repetition rate or a multiple of the frequency repetition rate.

WO 2010/010437 A1

FOURIER TRANSFORM SPECTROMETER WITH A FREQUENCY COMB LIGHT SOURCE

REFERENCE TO RELATED APPLICATIONS

[0001] The present application claims the benefit of U.S. Provisional Application No
5 61/083620 filed July 25th, 2008, the content of which is hereby incorporated by
reference in its entirety into the present disclosure.

FIELD OF THE INVENTION

[0002] The invention relates to the field of optical spectrometry. It is directed to a
Fourier spectrometer and to a method for measuring a spectrum of a sample using
10 such Fourier spectrometer.

DESCRIPTION OF RELATED ARTS

[0003] The present invention is more particularly directed to a Fourier
spectrometer comprising:

- a coherent light source;
- 15 - an interferometer adapted to separate, by amplitude or wavefront separation,
the coherent light source into two parts in order to generate interferences
between the two parts;
- detection means adapted to detect the interferences.

[0004] Such Fourier spectrometer is described e.g. in "Femtosecond laser Fourier
20 Transform absorption spectroscopy", Mandon et al. OPTICS LETTERS, June 15,
2007 Vol. 32, No. 12 p. 1677-1679. In this document the coherent light source is a
Cr⁴⁺:YAG femtosecond mode-locked laser.

[0005] However, the use of the Cr⁴⁺:YAG femtosecond mode-locked laser as light
source in the aforementioned document has several drawbacks. The repetition
25 rate of the mode-locked laser is not constant and the phase shift between the
pulses of the mode-locked laser is not stabilized. As a consequence, the spectrum
of the mode-locked does not exhibit a comb-like structure made of sharp and

equidistant frequency markers. Because this comb structure is missing, it is necessary to know the spectrum of some reference species of the sample in order to calibrate the spectrometer. Furthermore, interferences can only be measured between a frequency of the mode-locked laser and the same frequency shifted by
5 Doppler effect. Therefore, the noise level of the spectrometer is limited by the fringe scanning rate, typically in the audio domain, produced by the interferometer and by the amplitude noise of the mode-locked laser. In addition, such spectrometer can not provide simultaneous access to the absorption and dispersion experienced by the sample.

10 **[0006]** An object of the invention is to provide an improved Fourier spectrometer which is capable to overcome the aforementioned limitations of the known art.

[0007] The invention is based on the idea that frequency comb generators, which are mainly used in the context of metrology, can provide satisfactory stabilized pulses, overcoming the above cited drawbacks.

15 According to a first aspect, the invention relates to a Fourier transform spectrometer comprising:

- a coherent light source;
- an interferometer adapted to separate the coherent light source into two or more parts in order to generate through frequency- or phase-induced
20 effects, interferences between the two or more parts;
- detection means adapted to detect the interferences,

wherein the coherent light source comprises a frequency comb generator having a frequency repetition rate, and in a particular embodiment of the invention, the detection means may be adapted to detect the beating of pairs of frequencies of
25 the frequency comb separated by the frequency repetition rate or a multiple of the frequency repetition rate.

[0008] In the prior art, the detection was made from the beating of a certain frequency with the replica of this frequency, which is frequency-shifted by Doppler-

effect or phase- shifted effect produced by the moving arm of the interferometer,.
With the invention, the stability of repetition rate of the frequency comb is
advantageously used to make the detection from pairs of frequencies separated by
the frequency repetition rate or a multiple of the frequency repetition rate, i.e N
5 times the frequency repetition rate with $N \geq 1$.

[0009]With this new type of detection, the noise level of the interferogram is
decreased by at least 1000.

[0010]The interferometer is preferably an interferometer based on amplitude or
wavefront separation of the incoming source into two beams. For instance, it can
10 be a Michelson interferometer, which comprises in its simplest optical configuration
a fixed mirror, a moving mirror and separating means adapted to separate the
coherent light source into two parts, the first part being adapted to reflect on the
fixed mirror, and the second part being adapted to reflect on the moving mirror. All
traditional interferogram recording procedures (one or more or no moving mirror,
15 one or more or no fixed mirror, linear or not variations of the path difference
producing the interferogram) are usable.

BRIEF DESCRIPTION OF THE DRAWINGS

[0011]Preferred embodiments of the present invention will be set forth in detail
with reference to the drawings in which:

- 20 - FIG. 1 illustrates the down-conversion in a Fourier Transform spectrometer
with monochromatic source and a Michelson interferometer
- FIG. 2 illustrates the moving mirror effect for a Michelson interferometer
with a frequency comb as a source;
- FIG. 3 illustrates a first embodiment of a spectrometer according to the
25 invention;
- FIG. 4 illustrates the moving mirror effect for a Michelson interferometer
with a frequency comb as a source and the possibility of synchronous
detection at a rate determined by the comb repetition rate;

- FIG. 5 illustrates a second embodiment of a spectrometer according to the invention;
- FIG. 6 shows an absorption spectrum obtained with a spectrometer according to the invention;
- 5 - FIG. 7 is a comparison between experimental and calculated absorption and dispersion spectra, according to the invention;
- FIG. 8 and 9 illustrate an aspect of the invention for velocity modulation;
- FIG. 10 and 11 illustrate an aspect of the invention for Zeeman spectroscopy;
- 10 - FIG. 12 and 13 illustrate an aspect of the invention with polarization modulation.

[0012] Preferred embodiments of the present invention will be set forth in detail with reference to the drawings, in which like reference numeral refers to like elements throughout. The herein presented spectrometer, called Fourier Transform Spectrometer with a frequency comb light source or 1C-FTS hereafter, is primarily aimed at Fourier Transform Spectroscopy and all related instrumental methodologies (hyperspectral imaging, microscopy, vibrational circular dichroism, attenuated total reflection, Zeeman modulation, velocity modulation, selective detection techniques, time-resolved spectroscopy...), but it is noted that the two-beam interferometer with a frequency comb light source can also be used beyond the herein described applications. For example, the herein described two-beam interferometer with a frequency comb light source can be adapted to be used in Optical Coherence Tomography (OCT), interferometric length measurements, Light Detection And Ranging (LIDAR), reflectometry. Other interferometric applications, based on wavefront or amplitude recombination, not specifically described herein may also benefit from a two-beam or multiple-beam interferometer producing frequency- or phase-induced effects, with a frequency comb light source and the synchronous detection technique described hereafter.

30 **[0013]** As illustrated in FIG. 1 and known per se, Fourier Transform spectroscopy with monochromatic source and a Michelson interferometer provides a down-conversion of the optical frequencies to the audio range, with a down-conversion

factor equal to $2v/c$ where v is the interferometer moving mirror velocity and c is the speed of the light.

[0014] The frequency comb generator according to the invention is discussed. An optical Frequency Comb (FC) is an optical spectrum, which consists of phase-coherent equidistant laser lines. Frequency combs are well known in the art, for example from the patents "Generation of stabilized, ultra-short light pulses and the use thereof for synthesizing optical frequencies" R. Holzwarth, J. Reichert, T. Udem, T.W. Hänsch, US patent 6785303, 2004 or "Method and device for producing radio frequency waves", R. Holzwarth, T. Udem, T.W. Hänsch, US patent 7026594, 2006 or the publication "Optical frequency metrology" T. Udem, R. Holzwarth, T.W. Hänsch *Nature* **416**, 233 (2002) and are most often used in frequency metrology.

[0015] Most often, femtosecond lasers are used, leading to a femtosecond frequency comb (FFC). In such case, the distance f_{rep} between two consecutive lines depends on the mode locked laser cavity length. With femtosecond lasers, the spectral coverage is of the order of several hundreds of nm. Techniques of generation of a super continuum are available to increase this coverage. The number of the lines constituting a frequency comb may be then of the order of 10^6 or more. The comb lines frequencies may be known with extremely high accuracy. Details on femtosecond laser based optical frequency synthesis may be found in various articles, such as « Femtosecond optical frequency combs » Cundiff et al, Review of Modern Physics vol. 75, p. 325-342 (2003) or « Optical frequency metrology », Udem et al, Nature vol 416, p. 233-237 (2002).

[0016] Summarizing, when using a femtosecond frequency comb, ultra short pulses are periodically emitted by a mode-locked laser with a time period $T=l/v_g$ where l is the length of the laser cavity and v_g is the net group velocity. Due to dispersion in the cavity, the group and phase velocities differ, resulting in a phase shift of the carrier with respect to the peak of the envelope of each pulse. In the frequency domain the spectrum, Fourier transform of the train of periodic pulses, is made of a comb of laser modes, which are separated by the pulse repetition

frequency f_{rep} . The modes frequencies obey the relation: $f_n = n f_{\text{rep}} + f_0$, with n integer and f_0 due to -envelop pulse-to-pulse phase-shift. Presently the output spectrum of the comb can span more than one octave and the best level of stabilization of f_{rep} and f_0 is such that there is no deviation from a perfect grid larger than one part in 10^{19} .

[0017] In other words, a frequency comb is an optical spectrum which consists of equidistant lines. The generation of a frequency comb from a mode-locked laser requires that the periodicity applies not only to the pulse envelopes, but to the whole electric field of the pulses, including their optical phase, apart from a constant phase. Coherence between the pulses is required. The frequency comb generator can also be based on femtosecond oscillators broadened by supercontinuum generation in nonlinear fibers.

[0018] Frequency combs produced by femtosecond mode-locked lasers allow large spectral coverage thanks to their extremely short pulse duration. This spectral coverage can be further enhanced with spectral broadening based on highly nonlinear optical fibers through super-continuum generation. This spectral broadening is known to preserve the comb structure. The mode-locked laser may be broadened by a non-linear optical fiber and/or it may be coupled to a frequency conversion system such as difference/sum frequency generation, harmonic generation and/or parametric interaction.

[0019] Alternatively, four-wave mixing in an appropriate material, including toroidal microresonators or optical fibers, can produce the combs. A phase-modulated electro-optic device may also produce the combs.

[0020] According to a first embodiment of the invention, with an incoming frequency comb light source, the interferometer delivers, as a function of the path difference Δ , an interference pattern between two different frequency combs (Figure 2). The first comb reflected by the fixed mirror arm is similar to the initial comb, when the other one in the second arm is Doppler-shifted by the moving mirror. The interferogram recorded on a single detector, results from the optical

frequency down-conversion factor equal to $2v/c$, where v is the moving mirror velocity and c the speed of light. In general, the optical frequency down-conversion factor $2v/c$ traditionally shifts the infrared signatures to the audio frequency range (~ 10 kHz). Uppermost down-conversion factors ever reached to our knowledge with a moving mirror interferometer, have shifted the optical signatures down to the 1 MHz range (P. R. Griffiths, B. L. Hirsche, C. J. Manning, Ultra-rapid-scanning Fourier transform infrared spectrometry, *Vib. Spectrosc.* **19**, 165 (1999)), but the spectral resolution was then drastically limited (120 GHz). If the comb structure of the light source is resolved by the spectrometer, the resolved comb lines can be used for self-calibration of the wavenumber scale of the spectra. This is an important advantage because in traditional FTS without a frequency comb light source, the accuracy of the wavenumber scale is mostly limited by the slight misadjustments which always exist between the two different optical paths whereby the monochromatic reference and the analyzed source are recorded. In traditional FTS without a frequency comb light source, when accurate measurements are desired, samples providing internal molecular wavenumber standards must be placed on the path of the analyzed source and are simultaneously recorded during the experiment. With 1C-FTS, according to the invention, the accurate frequency markers provided by the comb source are available, when resolved, across the entire spectrum. This first embodiment of the invention is also a very simple fashion to improve signal to noise ratio or recording times in traditional FTS, due to the high brightness of the frequency comb source. A considerable advantage of our invention is that, unlike with high finesse cavities injected by frequency combs, no trade-off has to be made between sensitivity and spectral extension.

[0021] A spectrometer 1 according to the first embodiment of the invention is now described with reference to FIG. 3. The spectrometer 1 is used for Fourier Transform Spectroscopy with a frequency comb light source (1C-FTS). 1C-FTS consists of using a frequency comb 2, to probe the absorption of a sample of interest 3. The sample may be placed in a multipass cell or in a high finesse cavity. After interaction with the sample, the light is analyzed with a Fourier

transform interferometer 4 connected to an acquisition system 5. The resulting interferogram is Fourier-transformed to give the spectrum.

[0022] According to a second embodiment of the invention, thanks to the frequency comb periodic structure, it becomes possible to provide interfering signals at a much higher down-converted frequency, which has its carrier at the frequency comb repetition rate (140 MHz in our example in Figure 4). Furthermore, this carrier modulation frequency is not related to the speed of the moving mirror. The first row on Figure 4 represents the two combs interfering on the detector. Only four laser lines are selected on the second row showing two pairs of neighboring lines distant of 140 MHz. The traditional down-converted audio signal (10 kHz in our example in Figure 4) due to the Doppler-shift produced by the moving mirror is the interfering signature of each pairs of lines. This signal is frequency dependent; in other words, the distance between the lines in each pair varies linearly versus the frequency. On the other hand, the distance between each pair of lines has the same frequency variation, but it is shifted to the constant 140 MHz frequency. A synchronous detection of the beating signature between the four lines of the two pairs at the frequency comb repetition rate is therefore possible. The optical down-conversion factor is shifted in the radio-frequency range, which improves by 10^4 the frequency of the detection. Besides the potential reduction of the technical noise in the interferogram, the absorption and the dispersion of the spectral features are measured simultaneously within the same high resolution recording sequence. This second embodiment keeps all the other interests described in the first embodiment.

[0023] As illustrated FIG. 5, to enhance sensitivity, the sample may be placed in a multipass cell or high finesse cavity 6. Additionally, according to the second embodiment of the invention, as the light source possesses a comb structure, lock-in detection at the comb frequency rate may be performed with a lock-in device 7. The comb structure may be inherent to the light source or may be created with an external modulator, such as an EOM.

[0024] According to a specific example of the second embodiment, Proof-of-principle spectra are recorded with a Connes-type two-output stepping-mode interferometer equipped with fast InGaAs detectors. The laser frequency comb source generates pulses of ~40 fs with about 50 mW average output power in the 1.5 μm region. f_{rep} equals 140 MHz. Its cavity includes a Cr⁴⁺:YAG crystal pumped by a 1064nm Nd:YVO₄ laser, a semiconductor saturable absorber mirror for mode-locking, and chirped mirrors for dispersion compensation. A commercial lock-in amplifier performs synchronous detection. Data storage and computation are performed on personal computers. Broadband absorption and dispersion spectrum of C₂H₂ retrieved from synchronous rf detection at the repetition rate of a Cr⁴⁺:YAG frequency comb. FIG. 6 displays the absorption spectrum. The good comparison between experimental and calculated absorption and dispersion spectra, according to this specific embodiment of the invention, is given on FIG. 7. SNR is unsurprisingly several orders of magnitude less than expected due to several well understood limiting factors among which the inadequate electronic detection chain of the interferometric signal and the noisy behavior of the homemade femtosecond oscillator. The present limitation comes only from the restricted dynamic range of the commercial lock-in amplifier. It presently hampers SNR and resolution of the recorded spectra. Development of a dedicated electronics, based on well-tested methodological solutions can easily overcome this limitation. This demonstration clearly indicates the feasibility of the method according to the invention dedicated to the high resolution rapid and sensitive measurement of accurate absorption and dispersion profiles.

[0025] Supercontinua produced highly nonlinear fibers seeded by pico- or nanosecond mode-locked may be used for the practice of the invention. Depending on the noise on the pulse-to-pulse phase slip, a frequency comb may or may not be achieved from such sources. According to a specific embodiment of the invention, this is however enough to make real-time detection of the source repetition rate or to simply lock the pulse repetition rate. The radio-frequency detection of the interferogram may be then performed with or without the aid of an external modulator. According to the second embodiment of the invention

described above, the comb structure of the source enables to directly perform phase-sensitive radio-frequency detection at a multiple of the comb rate.

[0026] Expected sensitivity brought by FTS with a frequency comb light source is due to the combined advantages of laser brightness, Doppler limited resolution, cavity enhancement and high frequency modulation detection. Additionally, operating in the infrared domain where the spectral signatures are strong will contribute to enhance the sensitivity level. As the effects of laser brightness, resolution and infrared operation are embedded in the method, we discuss here the ways to increase absorption path length and to practice high frequency modulation

[0027] Long equivalent absorption path is obtained with a multipass cell or a high finesse cavity in which the sample to be analyzed has been inserted as shown in FIG. 5.

[0028] In tunable laser spectroscopy, high finesse cavities have been one of the most efficient ways to reach high sensitivity by cavity enhanced or cavity ring-down spectroscopies. Several attempts to couple a mode-locked laser to a high finesse cavity have been reported, for example in Gohle et al. "Frequency comb Vernier spectroscopy for broadband, high resolution, high-sensitivity absorption and dispersion spectra", Physical Review Letters vol.99, nb. 263902 (2007). To ensure efficient coupling into the cavity, all frequency components that make up the pulse train are tuned to resonance with the corresponding cavity modes. The major difficulty is to combine mirror characteristics of low-loss and dispersion-managed broad bandwidth. Though a broadband Ti:Sa frequency comb has been recently coherently coupled to a high finesse cavity ($F = \sim 5000$) across 100 nm, such experiments are complex as they require special mirror designs. They are spectral bandwidth limited. Matching an octave-spanning comb to a cavity with a finesse of several thousands is at the moment a delicate task, but only for technical reasons. The resulting severe restriction of the spectral bandwidth may represent a drastic limitation for Fourier spectrometers, if not for dispersive spectrometers.

[0029] An alternative approach can be implemented. It has the advantage that dispersion does not act as a filtering of the spectral bandwidth. The broadband laser is coupled to multipass cells equipped with mirrors made of broadband dielectric coatings for ultra short pulses. White-, Herriott- or Robert-type designs are appropriate amongst others. With a pessimistic value of 99% for the reflection coefficients, 500 m - 1 km path lengths are feasible from a 2m-base cell, thanks to the high output power ($> 10\text{mW}$) and small étendue of the laser beam. This brings sensitivity improvement of about 10^3 . Compensation of the dispersion will be performed, if necessary, at the output of the cell.

5 **[0030]** The low noise level is due to the original detection technique according to the invention taking advantage of the structure of the frequency comb.

[0031] To extract weak signals from a noisy background, modulation techniques are indeed recognized as one of the ideal tools. Small resonance information is encoded into a frequency region where the technical noise is relatively weak. Various schemes enable to compare on-resonant and off-resonant cases in a rapid succession. Subsequent demodulations generate a signal channel with no output unless there is a resonance. One of the most successful modulation techniques is called Frequency Modulation (FM) spectroscopy as disclosed in "Frequency-modulation spectroscopy: a technique for measuring weak absorptions and dispersions", Bjorklund, Optics Letters vol.5 p.15-17 (1980). Its capabilities of rapid and sensitive detection have rendered it very popular in non-linear laser spectroscopy. Its high sensitivity is mainly due to its high modulation frequency in the MHz or GHz frequency region, where usually the amplitude noise level of the laser source approaches the shot-noise limit. Such high frequency modulations may be achieved by modulating the injection current into a diode laser or using an external phase modulators. Up to now, FM spectroscopy has only been a tunable spectroscopy method. In most schemes, the laser wavelength is scanned across the atomic/molecular resonance to retrieve the line shape.

20 **[0032]** As explained before, the invention provides a new spectrometry offering
25
30 sensitivity, resolution, and broad spectral bandwidth based on high frequency

modulation. One of the main advantages of FTS is its experimental ability to record at once extended spectral ranges and to give easy access to the infrared domain. To achieve high sensitivity, a new way of modulating the interferogram has been demonstrated on a classical stepping-mode interferometer, for example in Mandon
5 et al "Frequency Modulation Fourier Transform Spectroscopy: a broadband method for measuring weak absorptions and dispersions", Optics Letters vol 32, p.2206-2208 (2007). The key concept is that rf modulation is performed. Both the absorption and the dispersion associated with the spectral feature are measured simultaneously.

10 **[0033]**With FTS with a frequency comb generator light source experiment, the beat signal at the output port of the Fourier transform spectrometer is modulated at a constant radio-frequency, which is about 10^4 times greater than the audio frequency generated by the interferometer optical conversion. It may be synchronously detected. The sensitivity increases proportionally to the modulation
15 frequency.

[0034]The comb structure may be directly available from the source or may be produced by an external modulator. Depending on the noise on the pulse-to-pulse phase slip, a 'real' frequency comb may or may not be achieved from the source. This is however enough to make real-time detection of the source repetition rate
20 that is directly fed to the lock-in or to simply lock the pulse repetition rate for these experiments.

[0035]Schemes for the implementation with 1C-FTS of some of the methodologies which are newly reachable thanks to 1C-FTS are now discussed

[0036]The first aspect of this implementation relates to selective spectroscopy.

25 **[0037]**Firstly, velocity modulation is intended to selectively detect the transitions of molecular ions. In most tunable-laser or classical FTS, configurations, an ac electric field inside a discharge changes the net drift velocity of the ions at the discharge frequency. This results in a synchronous Doppler shift of the frequency of their transitions, generally very small, whereas neutral species remain unshifted.

Synchronous detection at the ac modulation therefore cancels the neutral signatures.

[0038]With 1C-FTS, different schemes may be implemented. Only two are discussed here. Any combination of them may be used.

5 **[0039]**The first one makes use of a dc discharge as shown in FIG. 8. The laser frequency comb generator source can be split into two counter propagating beams, one for the red-shift and one for the blue and analyzed with a two-input two-output interferometer 9. Difference between the two resulting interferograms measured at the output 1 and output 2 of the interferometer which can be made by
10 differential detection as shown in Fig.8 or a posteriori, brings the selective information. Making the difference of the spectra instead of the interferograms is also appropriate.

[0040]As shown in FIG. 9, the second one exploits an ac modulated discharge
15 to acquire an interferogram recovered by synchronous detection at the frequency rate of the discharge modulation.

[0041]Secondly, in Zeeman spectroscopy, one typically periodically varies a magnetic field interacting with the source. After synchronous or differential detection, only the frequency shifted transitions by the magnetic field will then be detected. However, one must consider the symmetry of the Zeeman splitting: one
20 has to modulate the field between $B_c + B_M$ and $B_c - B_M$, where B_c and B_M are two constants values of the magnetic field. B_c can be equal to B_M but cannot be zero, otherwise no signal variation will be detected.

[0042]With 1C-FTS, it is possible either to modulate the magnetic field (as shown in FIG. 10) or to split the comb beam into two beams, one probing a cell with a
25 constant magnetic field $B_c + B_M$ while the other probes a cell with a constant magnetic field $B_c - B_M$ for differential detection with a two-input interferometer (as shown in FIG. 11).

[0043] Similarly to Zeeman spectroscopy, an electric field may be applied and modulated to selectively detect transitions that are sensitive to the Stark effect.

[0044] Thirdly, polarization modulation is useful to selectively detect polarisation-sensitive transitions. It is also called linear (comparison between s and p polarization) or vibrational circular dichroism (comparison left and right circularly polarized radiation). Some examples of the subject of studies are chiral molecules or the orientation of molecules in thin solid films, liquid crystals, or Zeeman transitions from paramagnetic species. The difference between the absorption of radiation by two polarization states is often extremely small. The idea is to compare, in a quick succession, spectra resulting from the interaction of the sample with light polarized in two different states.

[0045] With 1C-FTS, different schemes may be implemented. As shown in FIG. 12, it is possible to use a polarization modulator 11 on the comb beam and to measure in a quick succession one interferogram with a given polarisation and one second with the other polarization and to subtract them by synchronous detection or a posteriori. As shown in FIG. 13, it is also possible to split the comb beam into two beams, with complementary polarization 12 and 13 and to perform a direct differential detection.

[0046] Fourthly, concentration modulation is interesting for the selective detection of short-lived species. With 1C-FTS, the frequency comb generator probes a molecular source (typically a discharge) that is sinusoidally modulated at a given frequency. The beam at the output of the molecular source is analyzed by the interferometer according to the invention. The spectrum of the interferogram is detected at twice the frequency so that the transitions of all stable species (which have an intensity that is not modulated by the discharge source) are removed. By adjusting the phase of the detection, it is additionally possible to get information on the time behaviour of the source.

[0047] It is possible to simultaneously benefit in a single experiment from several of the detection schemes evocated above.

[0048] The second aspect of this implementation relates to time-resolved applications.

[0049] In conventional spectroscopy, time-resolved FTS is a powerful tool to investigate dynamic phenomena, with all the well-known advantages of FTS, especially the wide-spectral range of observation. It consists in performing a time sampling of the evolution of the observed source, at every optical path-difference positions. At the end of the experiment, as many interferograms as time samples of the evolution of the source are obtained and transformed to give spectra, each characterizing the light source at a given time.

[0050] Similarly, it is possible to develop Time-resolved 1C-FTS for improved dynamic studies. Various schemes may be implemented depending of the interferometer type and time-resolution which is looked at.

[0051] With a stepping mode interferometer, any kind of time resolution may be obtained. With a rapid-scan interferometer, the synchronization schemes available in the literature that have been successfully implemented may be used. Pump-probe experiments are also feasible when using a pulsed laser source, such as a femtosecond frequency comb, a supercontinuum source or a mode-locked laser.

[0052] It is noted that correlation analysis of the time-resolved or modulated spectra can also be performed.

[0053] The third aspect of this implementation relates to reflection spectroscopy.

[0054] With 1C-FTS, instead of looking at the light which is transmitted by the sample, it is possible to look at the light which is reflected by the sample. The reflection may be diffuse or specular. The sample can be a bulk material, a layer of material (thinner or thicker than the wavelength of the laser radiation) present on a flat reflective surface.

[0055] Furthermore, attenuated total reflection enables to probe samples in liquid or solid phase with very easy sample preparation. A probing light beam is passed through a well chosen crystal in such a way that it reflects at least once on the

internal surface in direct contact with the sample. This reflection forms an evanescent wave which extends into the sample, typically by a few micrometers. The attenuated energy from each evanescent wave is passed back to the light beam and the beam transmitted by the crystal is then collected by a FT spectrometer as it exits the crystal.

[0056] Attenuated total reflection 1C-FTS may be easily implemented with the laser beam probing the crystal/sample assembly.

[0057] The invention can also be adapted to spatially resolved measurements as described below.

10 **[0058]** Firstly, as the section of a laser beam can be small, it is possible to selectively probe tiny spatial regions of a macroscopic sample.

[0059] Secondly, an efficient way to map the composition of a sample is to measure all the FT spectra simultaneously with an array detector. Simultaneous measurement of spectra from each point of an image is called hyperspectral imaging, and the array of spectra obtained is an hypercube.

15 **[0060]** With 1C-FTS, it is similarly possible to image an object on an array detector at the output of the interferometer.

[0061] Thirdly, microscopy with 1C-FTS should bring together the advantages of microscopy with Fourier transform spectroscopy and microscopy with laser sources. Increase of spatial resolution can be expected together with accurate spectral diagnostics.

[0062] Fourthly, due to the low divergence and high intensity of laser beams, 1C-FTS can probe long columns of sample. Alternatively, a laser beam may propagate into a long distance before reaching the sample of interest.

25 **[0063]** LIDAR-type 1C-FTS experiment can also be implemented: the sample-scattered light from an intense broadband laser can be collected and analysed.

[0064] The following aspects of the invention should also be considered.

[0065]With the aid of non-linear processes (for instance difference and sum frequency generation, parametric interaction, optical rectification, harmonic generation...), it is possible to develop 1C-FTS in spectral regions which are presently difficult to access: THz or VUV regions for instance. It is also possible to
5 use the inverse nonlinear process for the detection scheme, ie to re-convert the light to a region where sensitive detectors are available.

[0066]Furthermore, 1C-FTS is expected to be a tool for diagnosing various media, such as plasmas, ambient air, industrial production chains, leak detection, hazardous gas detection, etc...All the classical qualities of optical spectroscopy
10 are preserved: *in situ*, local or remote operation, non intrusive diagnostic, quantitative measurements...

[0067]The photon detectors may consist of simple photodetectors (photodiode, bolometer, antenna) or non-linear frequency converters, e.g frequency doubling devices, coupled to photodetectors. It is noted that the photon detector may be
15 replaced by a microphone or a high Q piezoelectric crystal element such as quartz crystal tuning forks.

[0068]Gas chromatography (GC), High Performance Liquid Chromatography (HPLC) or Supercritical fluid chromatography (SFC) may be coupled to 1C-FTS.

CLAIMS

1. A Fourier transform spectrometer comprising:
- 5 - a coherent light source;
- an interferometer, based on amplitude or wavefront division, adapted to separate the coherent light source into two parts in order to generate interferences between the two parts;
- detection means adapted to detect the interferences,
- 10 wherein the coherent light source comprises a frequency comb generator having a defined frequency repetition rate.
2. A Fourier transform spectrometer according to claim 1 wherein the detection means are adapted to detect the beating of pairs of frequencies of the frequency comb separated by the frequency repetition rate or a multiple of the frequency
- 15 repetition rate.
3. A Fourier transform spectrometer according to claim 1 wherein the interferometer is a Michelson interferometer.
4. A Fourier transform spectrometer according to claim 1 or 2 further comprising at least one multipass cell adapted to receive a sample to be analyzed by the
- 20 spectrometer.
5. A Fourier transform spectrometer according to claim 1 or 2 further comprising at least one high finesse cavity adapted to receive a sample to be analyzed by the spectrometer.

25

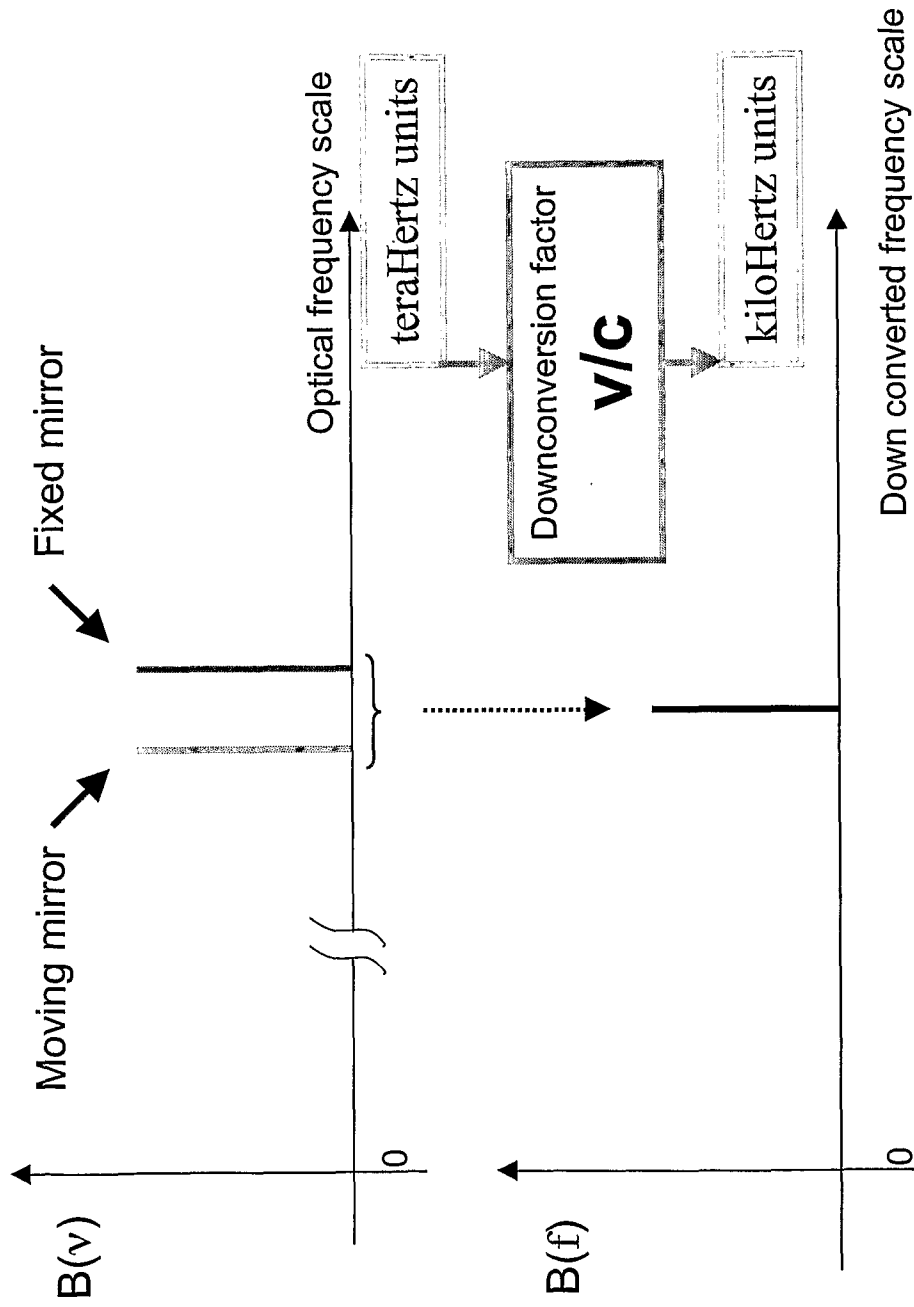
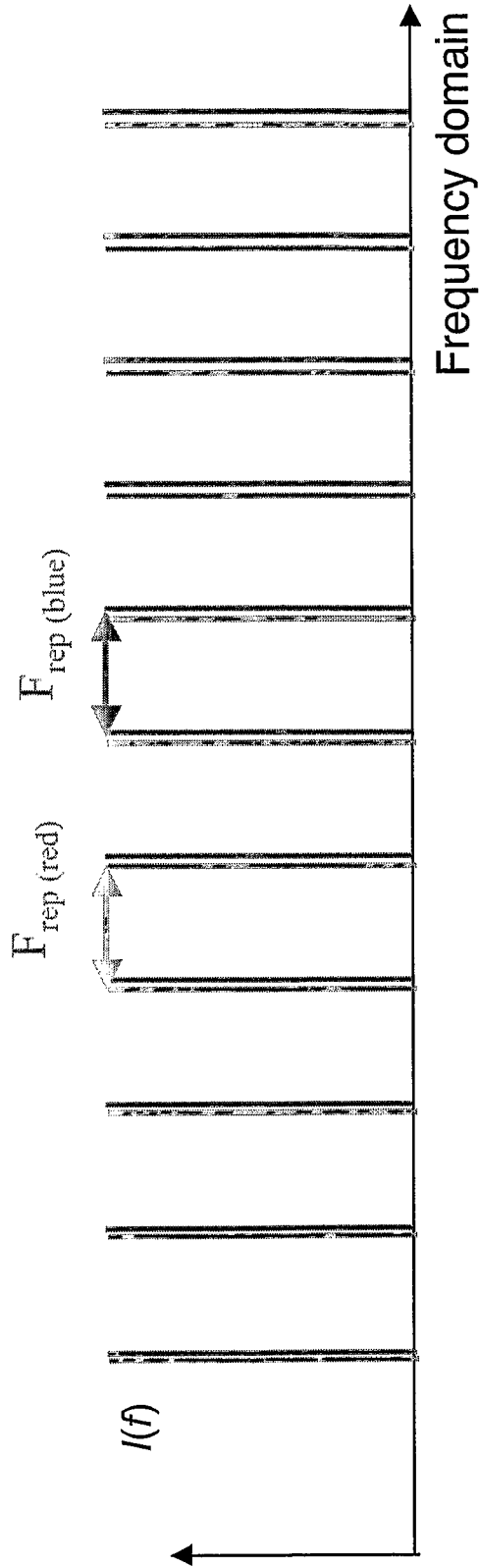

FIG. 1

FIG. 2



Moving mirror effect

$$F_{\text{rep}}(\text{red}) = f_{\text{rep}}(\text{blue}) (1 - 2v/c)$$

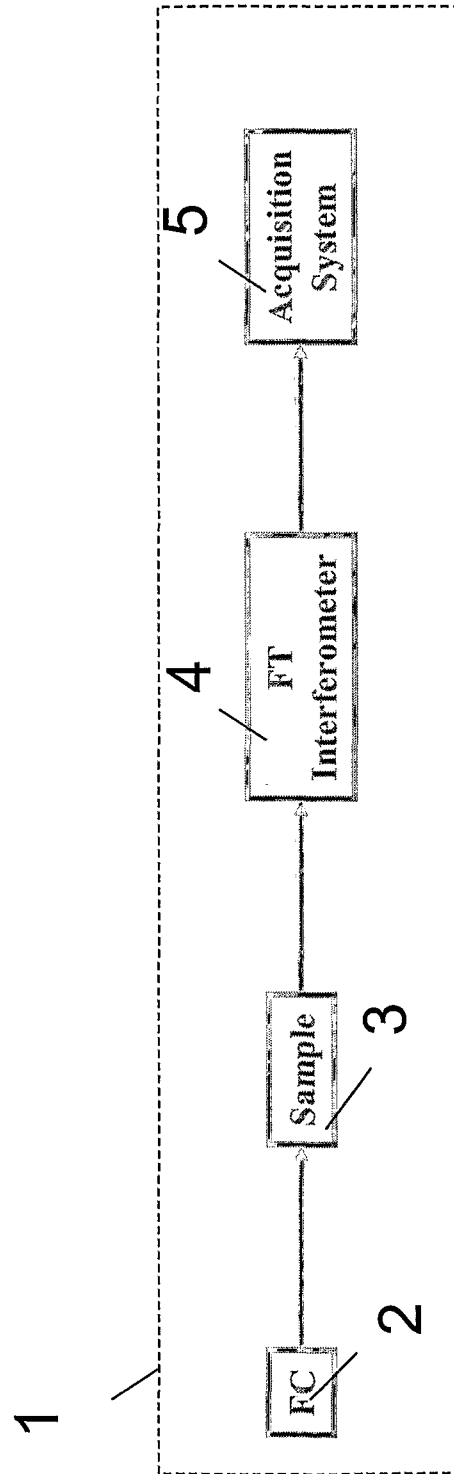

FIG. 3

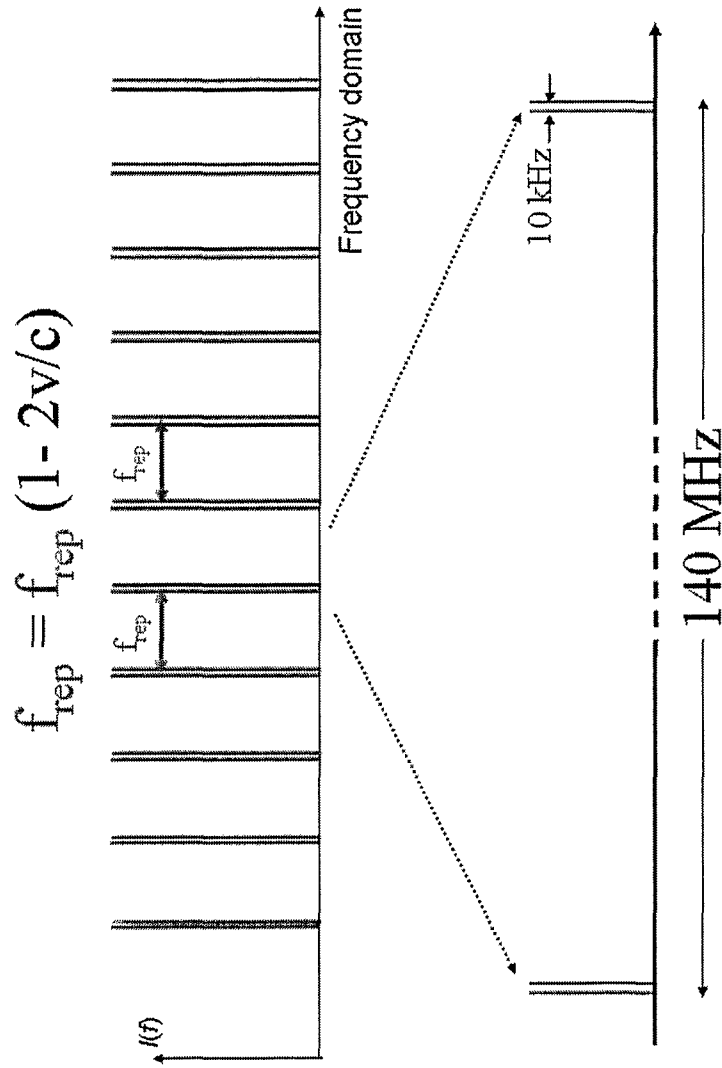

FIG. 4

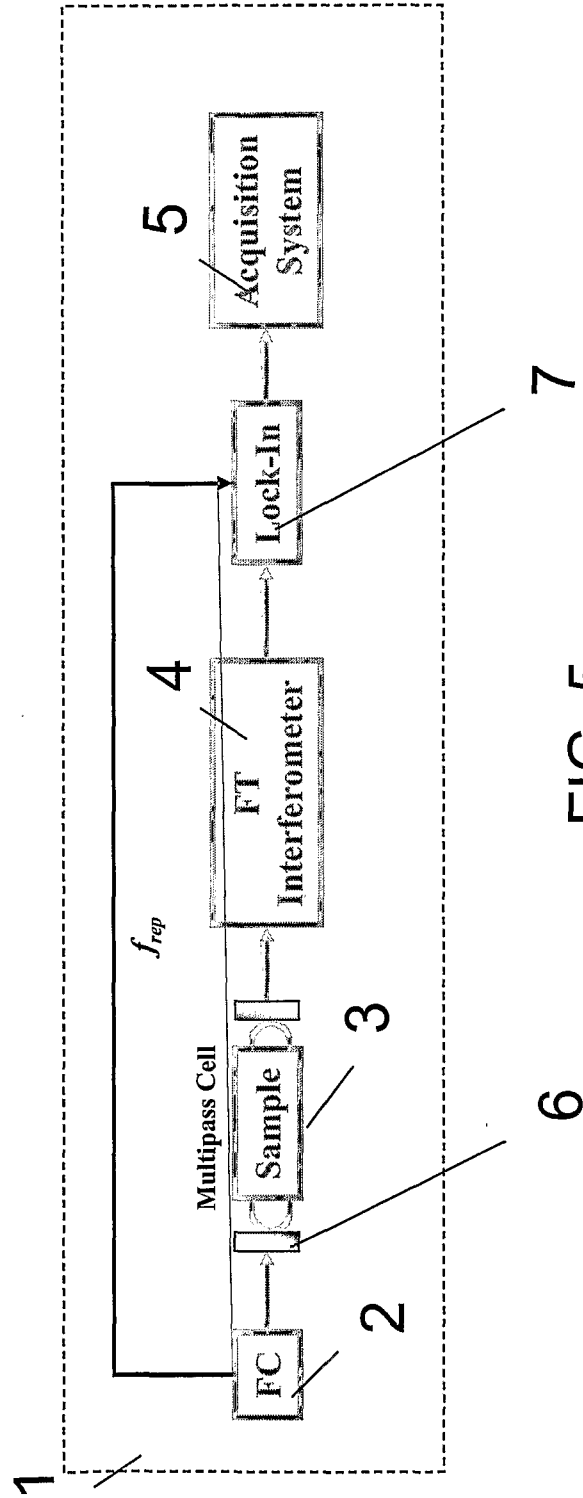

FIG. 5

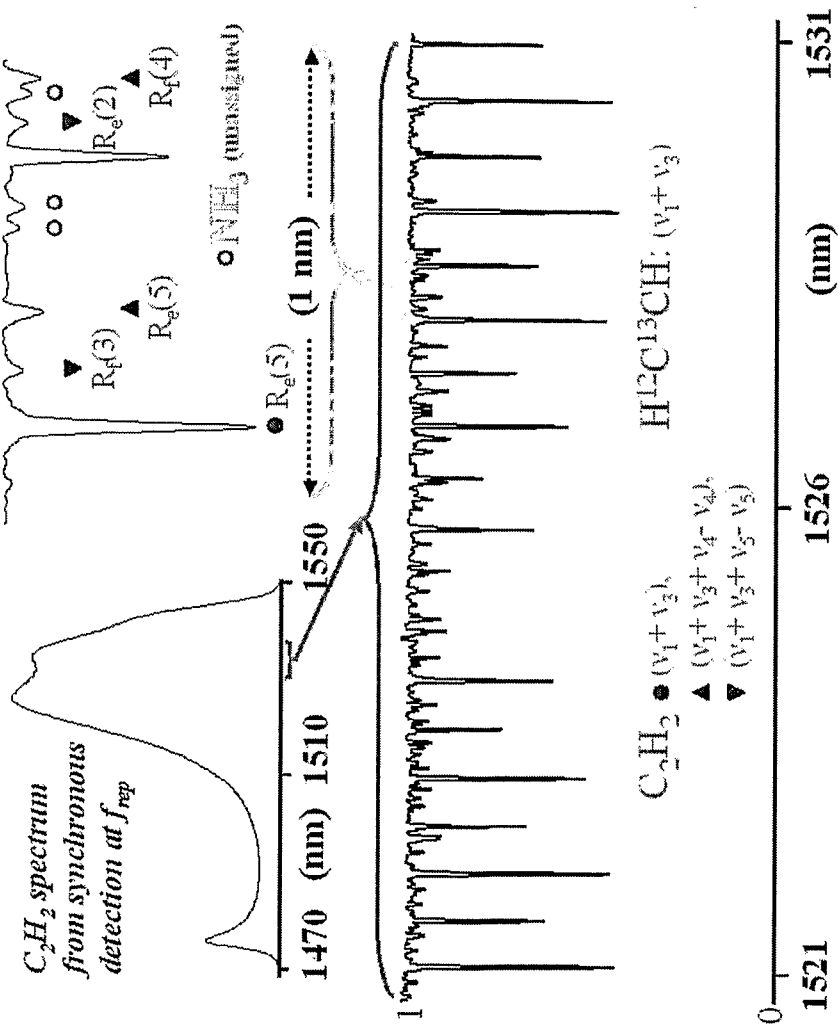

FIG. 6

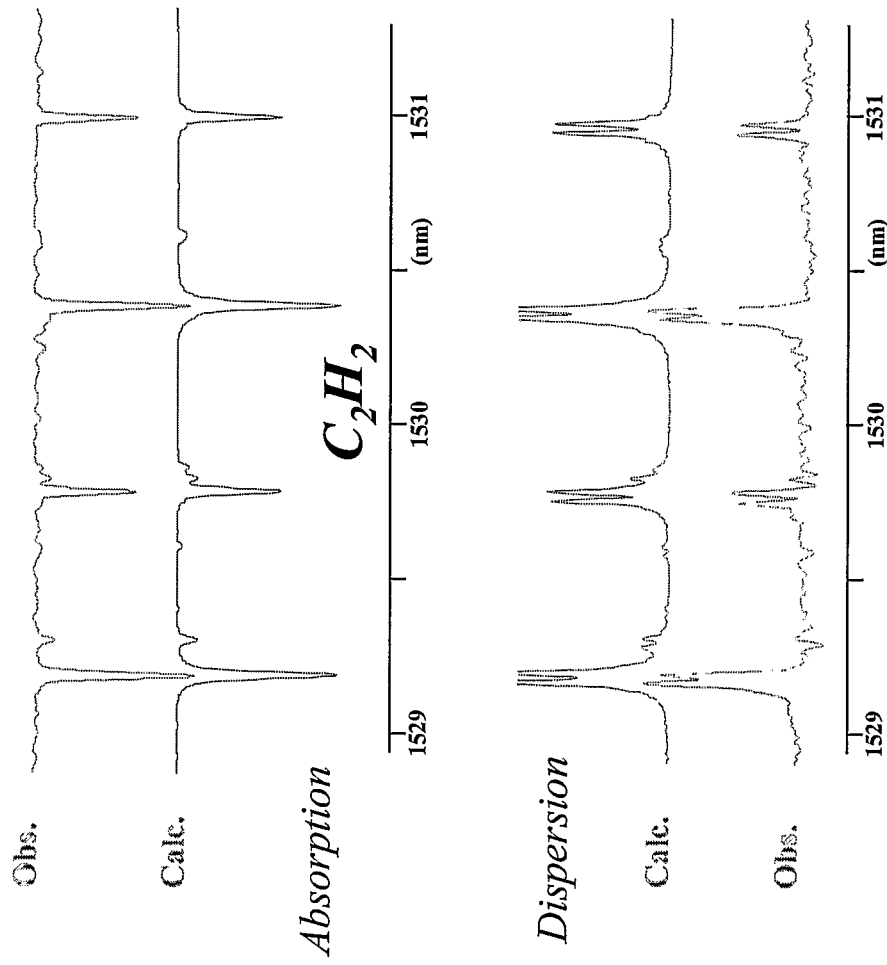

FIG. 7

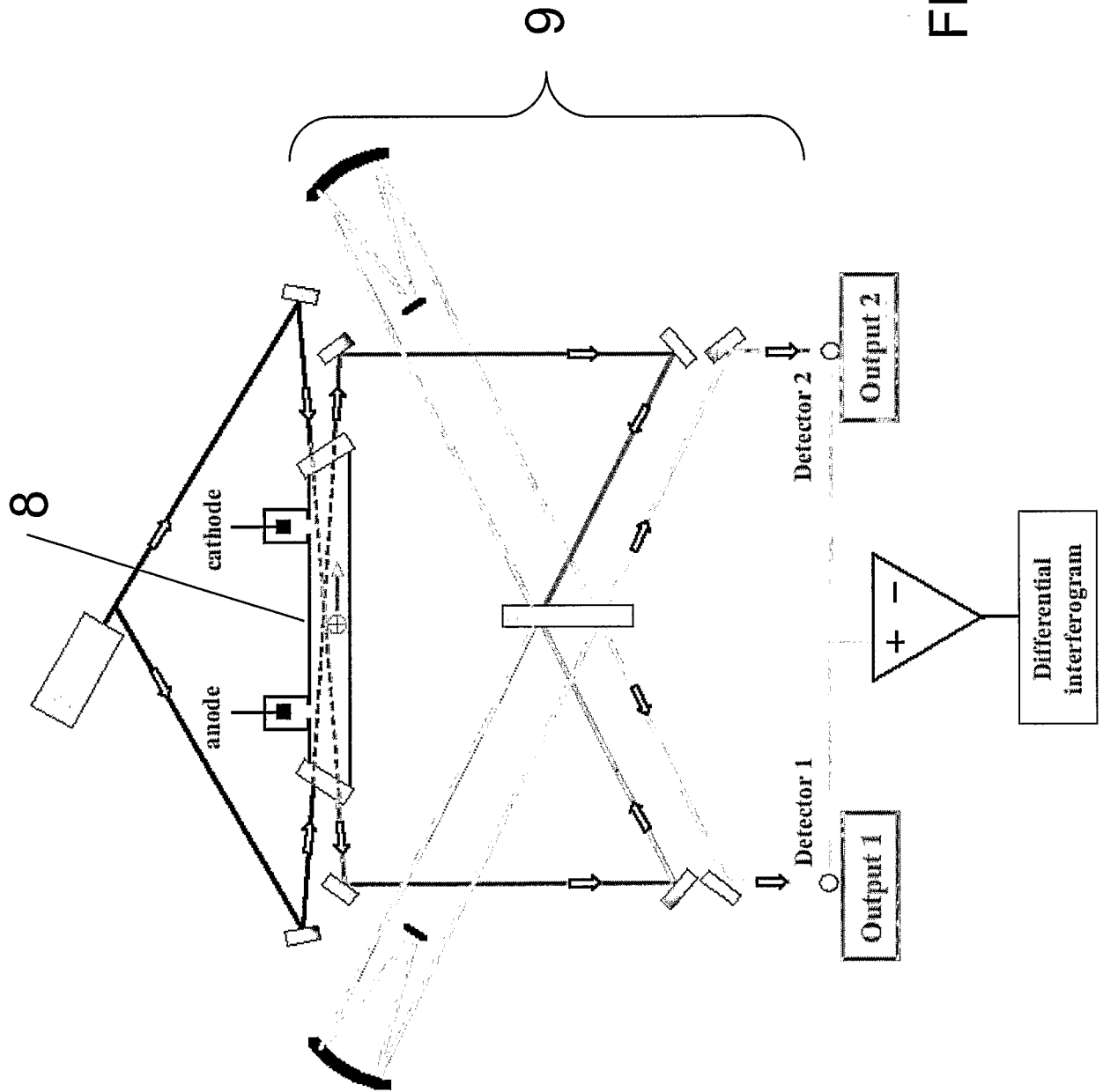

FIG. 8

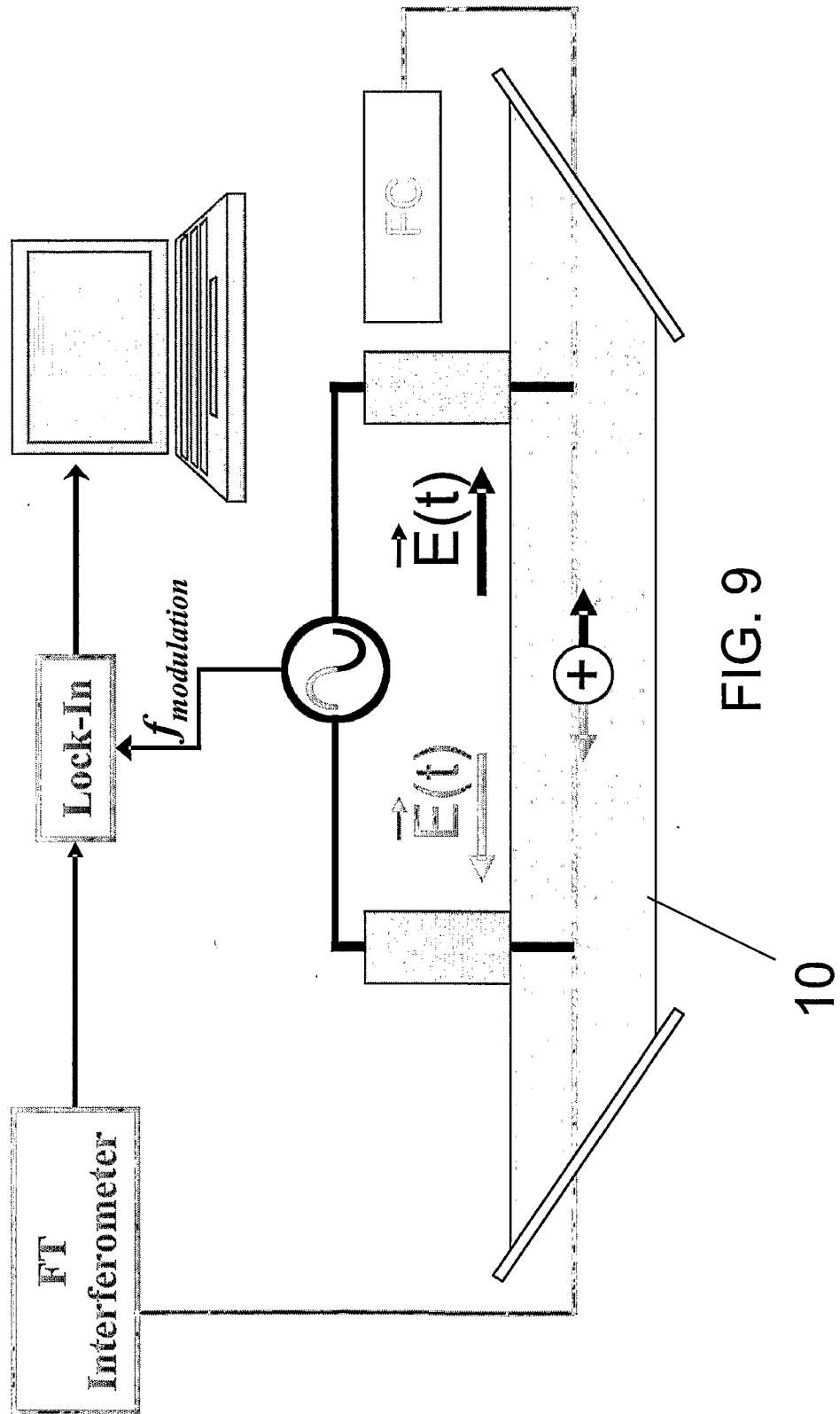

FIG. 9

10

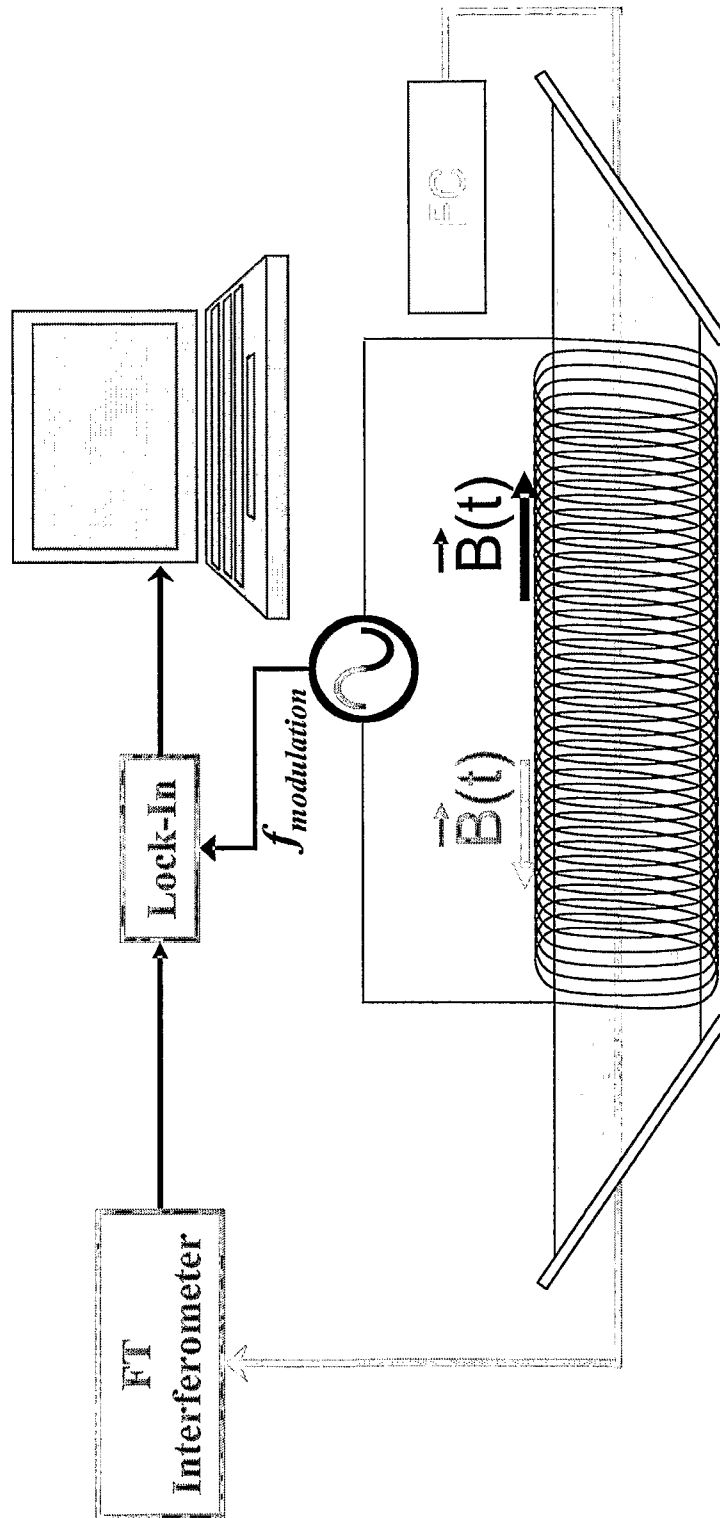

FIG. 10

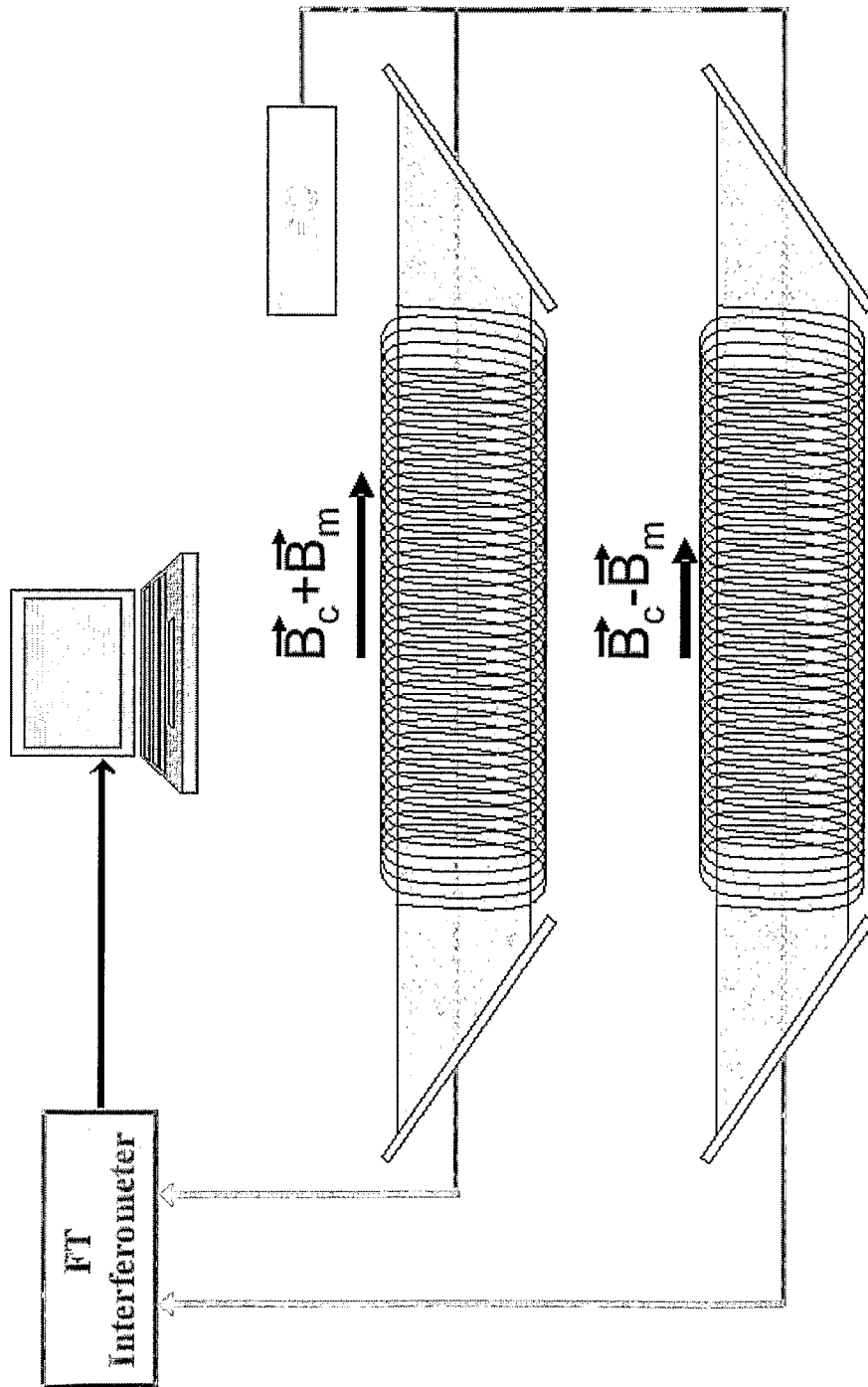

FIG. 11

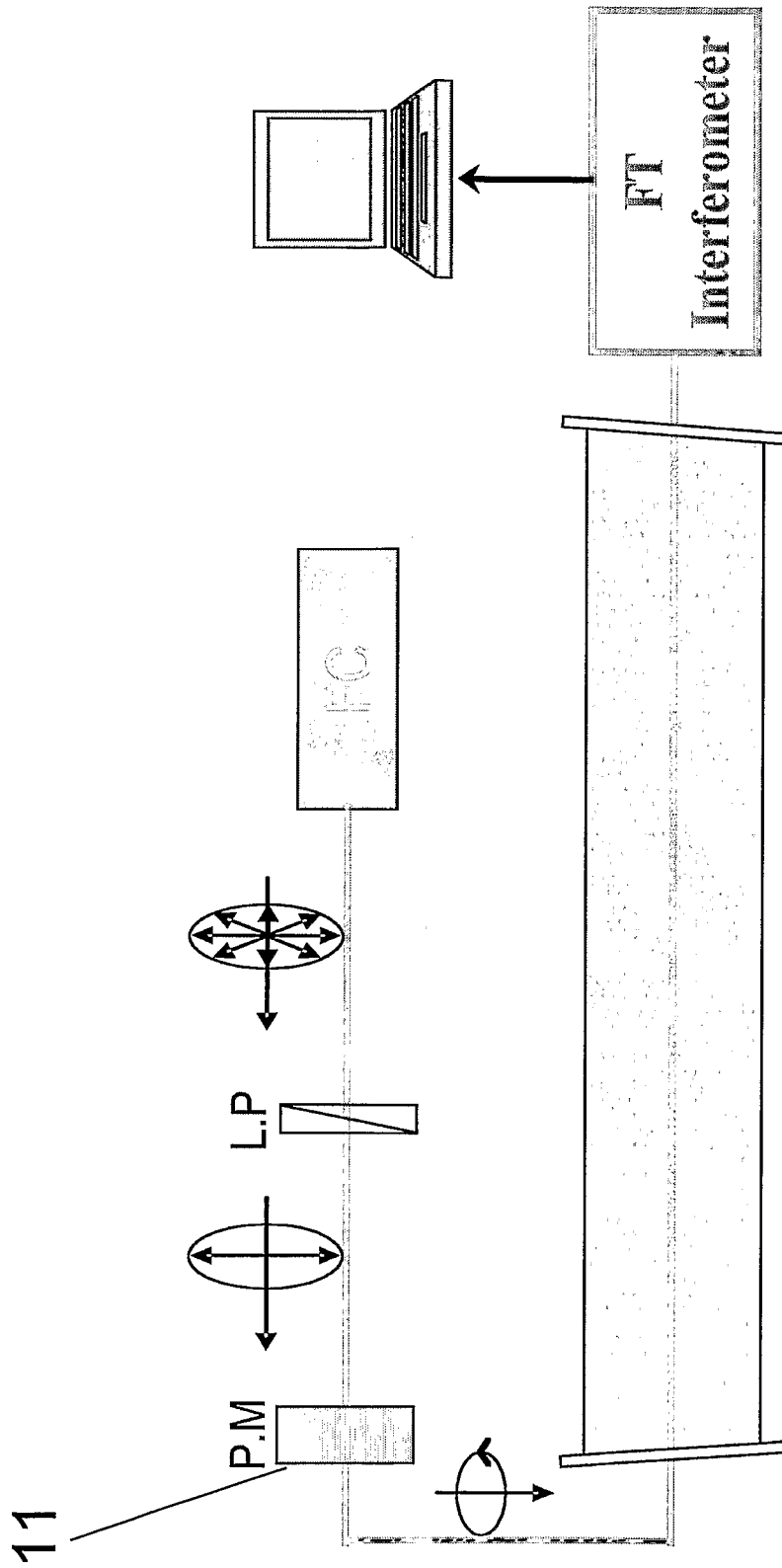

FIG. 12

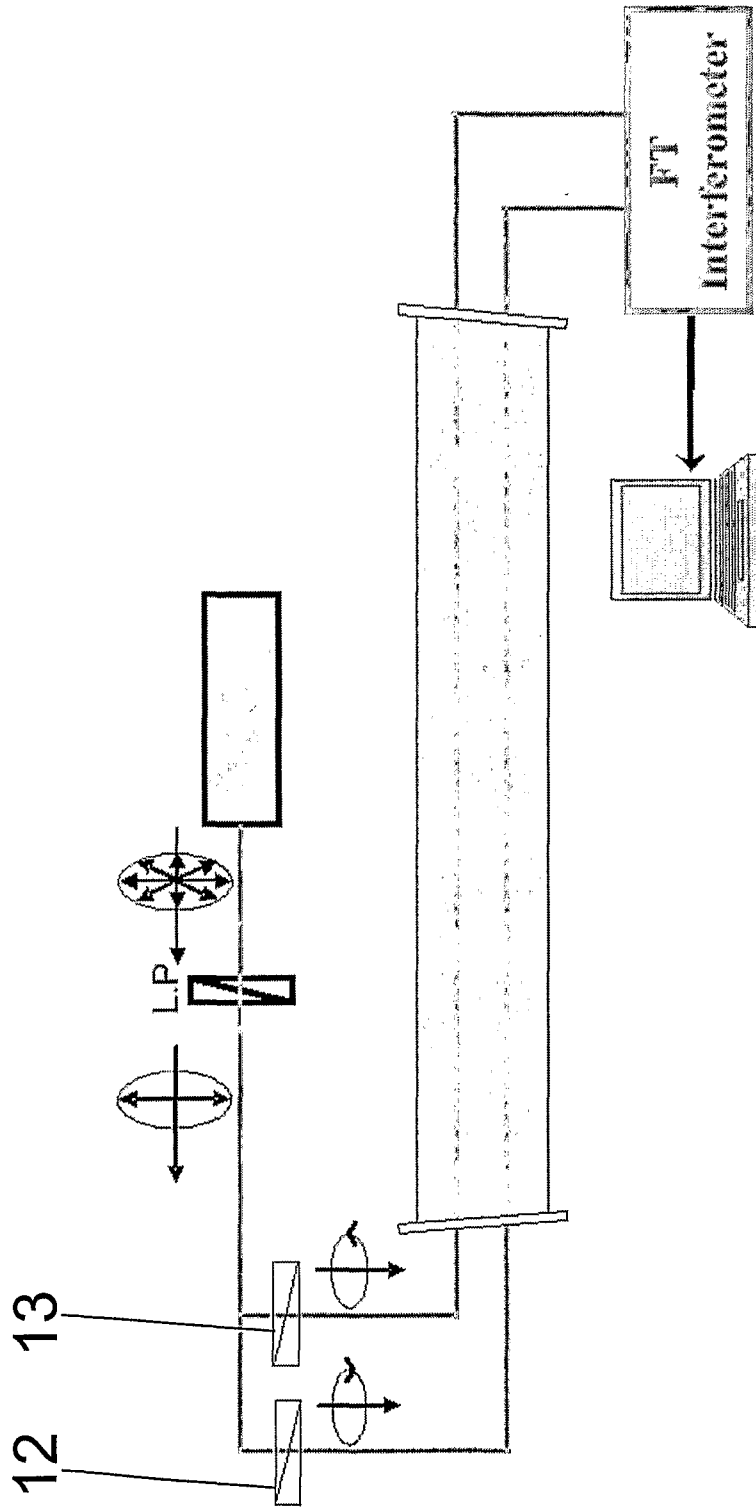

FIG. 13

INTERNATIONAL SEARCH REPORT

International application No
PCT/IB2009/006282

A. CLASSIFICATION OF SUBJECT MATTER
INV. G01J3/453

According to International Patent Classification (IPC) or to both national classification and IPC

B. FIELDS SEARCHED

Minimum documentation searched (classification system followed by classification symbols)
G01J

Documentation searched other than minimum documentation to the extent that such documents are included in the fields searched

Electronic data base consulted during the international search (name of data base and, where practical, search terms used)

EPO-Internal, INSPEC

C. DOCUMENTS CONSIDERED TO BE RELEVANT

Category*	Citation of document, with indication, where appropriate, of the relevant passages	Relevant to claim No.
X	J. ZHANG, Z.H. LU AND L.J. WANG: "Precision measurement of the refractive index of air with frequency combs" OPTICS LETTERS, vol. 30, no. 24, 15 December 2005 (2005-12-15), pages 3314-3316, XP002549472 abstract; figure 1 page 3314, column 1, line 29 - page 3315, column 1, line 16 ----- -/--	1-5

Further documents are listed in the continuation of Box C.

See patent family annex.

* Special categories of cited documents :

- *A* document defining the general state of the art which is not considered to be of particular relevance
- *E* earlier document but published on or after the international filing date
- *L* document which may throw doubts on priority claim(s) or which is cited to establish the publication date of another citation or other special reason (as specified)
- *O* document referring to an oral disclosure, use, exhibition or other means
- *P* document published prior to the international filing date but later than the priority date claimed

- *T* later document published after the international filing date or priority date and not in conflict with the application but cited to understand the principle or theory underlying the invention
- *X* document of particular relevance; the claimed invention cannot be considered novel or cannot be considered to involve an inventive step when the document is taken alone
- *Y* document of particular relevance; the claimed invention cannot be considered to involve an inventive step when the document is combined with one or more other such documents, such combination being obvious to a person skilled in the art.
- * & * document member of the same patent family

Date of the actual completion of the international search

9 October 2009

Date of mailing of the international search report

29/10/2009

Name and mailing address of the ISA/

European Patent Office, P.B. 5818 Patentlaan 2
NL - 2280 HV Rijswijk
Tel. (+31-70) 340-2040,
Fax: (+31-70) 340-3016

Authorized officer

Varelas, Dimitrios

INTERNATIONAL SEARCH REPORT

International application No
PCT/IB2009/006282

C(Continuation). DOCUMENTS CONSIDERED TO BE RELEVANT

Category*	Citation of document, with indication, where appropriate, of the relevant passages	Relevant to claim No.
X	<p>C. GOHLE, B. STEIN, A. SCHLIESSER, T. UDEM, T. HÄNSCH: "Frequency Comb Vernier Spectroscopy for Broadband, High-Resolution, High-Sensitivity Absorption and Dispersion Spectra" PHYSICAL REVIEW LETTERS, vol. 99, 263902, 28 December 2007 (2007-12-28), pages 263902-1-263902-4, XP002549473 abstract; figure 1 pages 263902-1, column 2, line 4 - pages 263902-2, column 2, line 8</p> <p>-----</p>	1-5
X,P	<p>J. MANDON, G. GUELACHVILI, N. PICQUÉ: "Fourier transform spectroscopy with a laser frequency comb" NATURE PHOTONICS, vol. 3, 25 January 2009 (2009-01-25), pages 99-102, XP002549474 the whole document</p> <p>-----</p>	1-5