



INTERNATIONAL APPLICATION PUBLISHED UNDER THE PATENT COOPERATION TREATY (PCT)

<p>(51) International Patent Classification ⁶ : B65F 1/06, 1/16</p>	<p>A1</p>	<p>(11) International Publication Number: WO 99/39995 (43) International Publication Date: 12 August 1999 (12.08.99)</p>
<p>(21) International Application Number: PCT/GB99/00243 (22) International Filing Date: 25 January 1999 (25.01.99) (30) Priority Data: 9802738.6 9 February 1998 (09.02.98) GB (71) Applicant: SANGENIC INTERNATIONAL LIMITED [GB/GB]; Worsley Bridge Road, Lower Sydenham, London SE26 5HP (GB). (72) Inventor: FIRTH, Robert; 92 Deanwood Crescent, Allerton, Bradford, West Yorkshire BD15 9BL (GB). (74) Agents: ROBERTS, Gwilym, Vaughan et al.; Kilburn & Strode, 20 Red Lion Street, London WC1R 4PJ (GB).</p>	<p>(81) Designated States: AL, AM, AT, AU, AZ, BA, BB, BG, BR, BY, CH, CN, CU, CZ, DE, DK, EE, ES, FI, GB, GD, GE, GH, GM, HR, HU, ID, IL, IN, IS, JP, KE, KG, KP, KR, KZ, LC, LK, LR, LS, LT, LU, LV, MD, MG, MK, MN, MW, NO, NZ, PL, PT, RO, RU, SD, SE, SG, SI, SK, SL, TJ, TM, TR, TT, UA, UG, UZ, VN, YU, ZW, ARIPO patent (GH, GM, KE, LS, MW, SD, SZ, UG, ZW), Eurasian patent (AM, AZ, BY, KG, KZ, MD, RU, TJ, TM), European patent (AT, BE, CH, CY, DE, DK, ES, FI, FR, GB, GR, IE, IT, LU, MC, NL, PT, SE), OAPI patent (BF, BJ, CF, CG, CI, CM, GA, GN, GW, ML, MR, NE, SN, TD, TG).</p> <p>Published <i>With international search report.</i></p>	

(54) Title: WASTE STORAGE DEVICE

(57) Abstract

A waste storage device comprises a container (21) having a neck (12) through which flexible tubing (2) is fed to receive soiled products such as a baby's nappy. The neck is twisted relative to the container to close the tubing around a nappy. A lid (70) is hinged to the container and closes the neck and includes a rotating cutter to sever the tubing.

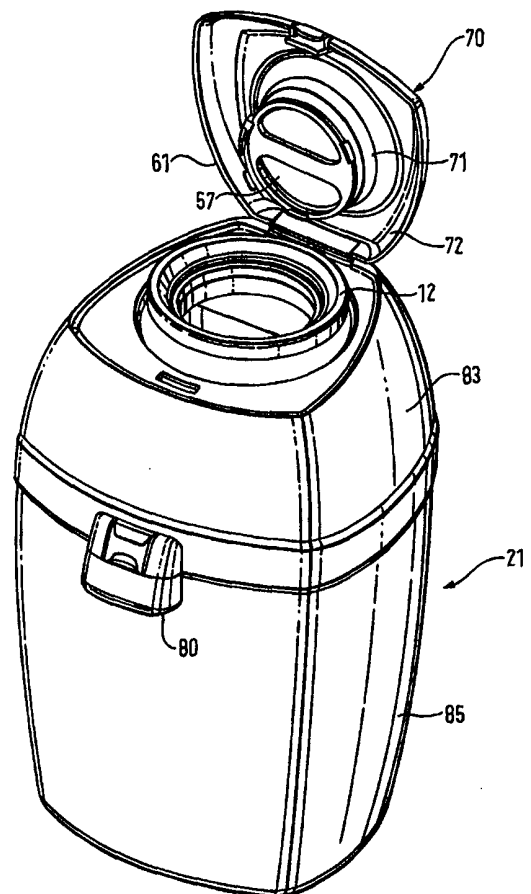

FOR THE PURPOSES OF INFORMATION ONLY

Codes used to identify States party to the PCT on the front pages of pamphlets publishing international applications under the PCT.

AL	Albania	ES	Spain	LS	Lesotho	SI	Slovenia
AM	Armenia	FI	Finland	LT	Lithuania	SK	Slovakia
AT	Austria	FR	France	LU	Luxembourg	SN	Senegal
AU	Australia	GA	Gabon	LV	Latvia	SZ	Swaziland
AZ	Azerbaijan	GB	United Kingdom	MC	Monaco	TD	Chad
BA	Bosnia and Herzegovina	GE	Georgia	MD	Republic of Moldova	TG	Togo
BB	Barbados	GH	Ghana	MG	Madagascar	TJ	Tajikistan
BE	Belgium	GN	Guinea	MK	The former Yugoslav Republic of Macedonia	TM	Turkmenistan
BF	Burkina Faso	GR	Greece	ML	Mali	TR	Turkey
BG	Bulgaria	HU	Hungary	MN	Mongolia	TT	Trinidad and Tobago
BJ	Benin	IE	Ireland	MR	Mauritania	UA	Ukraine
BR	Brazil	IL	Israel	MW	Malawi	UG	Uganda
BY	Belarus	IS	Iceland	MX	Mexico	US	United States of America
CA	Canada	IT	Italy	NE	Niger	UZ	Uzbekistan
CF	Central African Republic	JP	Japan	NL	Netherlands	VN	Viet Nam
CG	Congo	KE	Kenya	NO	Norway	YU	Yugoslavia
CH	Switzerland	KG	Kyrgyzstan	NZ	New Zealand	ZW	Zimbabwe
CI	Côte d'Ivoire	KP	Democratic People's Republic of Korea	PL	Poland		
CM	Cameroon	KR	Republic of Korea	PT	Portugal		
CN	China	KZ	Kazakstan	RO	Romania		
CU	Cuba	LC	Saint Lucia	RU	Russian Federation		
CZ	Czech Republic	LI	Liechtenstein	SD	Sudan		
DE	Germany	LK	Sri Lanka	SE	Sweden		
DK	Denmark	LR	Liberia	SG	Singapore		
EE	Estonia						

Waste Storage Device

The invention relates to a waste storage device and a method of operation
5 of such a device.

One known waste storage device is disclosed in GB Patent No. 2206094
and described here with reference to Fig. 1. The device is particularly useful for
the storage for subsequent disposal of waste such as babies nappies or other
personal waste material. A plastics container 21 is formed with an internal flange
10 22 from which a cylinder 23 extends upwards. A pack consisting of a tubular core
1 inside a profusely circumferentially pleated length of flexible tubing 2 is located
in the container 21 with the core 1 resting on the flange 22 and rotatable on the
cylinder 23. To begin using the pack to form a series of packages of objects,
which in this particular example will be considered to be a babies' disposable
15 nappies, the top of the flexible tubing 2 is pulled upwards and tied into a knot 24.
This closed end can then form the bottom of a package to be formed along the
length of part of the tubing. This is effected by pushing the closed end
downwards inside the core 1 and cylinder 23 by the object to be packaged. As
this is being done the flexible tubing 2 from the pleated length slides over the top
20 edge 25 (Fig. 1) of the core 1 which is made sufficiently smooth to prevent the
flexible tubing from being damaged. The core 1 may be approximately four
inches (10.16cm) diameter but, of course, the diameter of the flexible tubing 2 is
substantially more than this.

When the object has been thrust well into the concentric core 1 and
25 cylinder 23, the package is closed by twisting the flexible tubing 2 above the
object as at 30 (Fig. 1). This is done by turning the core 1 with remaining pleated
tubing thereon about the core axis. A unit 31 is formed for this purpose in that it

has a depending annular flange 50 formed with an outer surface that is a taper fit in a frusto-conical inner surface 51 at the top of the core 1. The package is prevented from turning about the axis of the core during this manual twisting action by springs 52 fixed to the container 21 and projecting radially inwards to engage the package. These springs are equidistantly spaced round the container 21. Shallow, grooves dividing upwardly extending ridges are formed on the frusto-conical inner surface 51 to stop slippage of the flexible tubing during the twisting operating.

By the aforesaid means, a series of connected closed packages 35 are formed and this can be continued until the pleated tubing 2 is exhausted. In the arrangement of Fig. 1 the packages collect in a bin portion 36 of the container closed at the bottom by a hinged base 53 normally held closed by a manually operable catch of suitable type. When it is desired to remove the packages from the bin portion 36 for transport to a waste disposal facility, the uppermost package is severed above its upper twisted closure 30 and the hinged base 53 opened for the removal of the packages through the end of the bin portion. Even if the twisted seals between the packages become loosened, the lid and the newly formed topmost twisted seal will prevent the escape of odours, vapours and gases to the ambient atmosphere. However, it has been found that when the tubing 2 is made of high density polyethylene the twisted joints remain remarkably tight.

A development of this arrangement is disclosed in GB 2292725 and described here with reference to Fig. 2. It will be seen that an outwardly flared funnel 12 having an inlet edge 15 is detachably connected to the top of the core 1 by a taper joint 16. The funnel improves the hygiene of the device yet further because the flexible tubing 2 is drawn from the pack as an object is pushed down, over the inlet edge 15 of the funnel 12 to present a fresh and hygienic layer of tubing in the flared part of the funnel. The funnel 12 is twisted to obtain the

twisted closure 30. An alternative spring arrangement 14 is shown in Fig. 2 and described fully in GB 2292725.

5 GB 2206094 and GB2292725 both additionally disclose a cutting arrangement for severing the tubing when it is desired to remove the packages for disposal. Referring to Fig. 3, the severing means is incorporated in the unit 31 which is a bipartite unit comprising an outer ring 55 formed with a flange 50 that locks into the top of the core 1 or funnel 12 and a disc 56 which is freely rotatable in the ring 55. The disc 56 comprises a circular transparent sheet 57, through which the user can see the twisted flexible tubing, set in an angle section ring 10 having a horizontal flange 58 and a vertical flange 59 (Fig. 1) located between narrow flanges inside the relatively stationary flange 50. In the angle of the ring 58,59 three finger pieces 60 are fixed 120° apart above the transparent sheet 57. A cutter unit 61 is fixed beneath the flange 58. This device has an upper arcuate part 62 and a lower tapered shoe 63 with a gap between them along the major 15 portion of their length. Close to the closed termination of this gap a metal cutter blade 64 is fixed as close as possible to the relatively stationary flange 50 so that the blade is shrouded against doing any damage to a person's fingers when the lid 31 is removed. The predominant material for the lid may be plastics material or metal.

20 To operate the cutter unit 61, the disc 56 is turned by means of the finger pieces 60 or any other suitable finger pieces through a full revolution. In this movement the tapered shoe 63 pierces through the radially pleated taut portion 65 of the flexible tubing that flares outwards from the topmost twist 30 to the core 1. Further rotation of the disc 56 causes the cutter blade 64 to cut round the tubing 25 material, cleanly separately the uppermost package from the flexible tubing remaining on the core 1.

These known cutting arrangements are however relatively cumbersome, complex and/or can be lost or misplaced.

According to the invention there is provided a waste storage device comprising a main body and a lid, the main body including a waste aperture inlet
5 arranged to receive a storage bag, the lid comprising storage bag severing means movably mounted thereon and a formation arranged to hold the storage bag against movement relative to the lid when the lid is in a closed position, for operation of the severing means, in which the lid is movably fastened to the main body between said closed position and an open position. As a result there is no
10 risk of misplacing the severing means, the number of steps in the cutting operation are reduced and a greater level of hygiene is afforded.

Preferably the lid is guided between said open and closed positions by the movable fastening, allowing simple location of the severing means. The lid may be hinged to the main body, allowing a simple movable fastening.

15 The waste inlet aperture may include an outwardly flared upper end enclosed by the lid in the closed position, allowing increased hygiene on insertion of waste and enclosure of the entire waste inlet aperture.

The lid further preferably includes detent means releasably fixing the severing means against movement relative to the lid making the device secure and
20 tamper-proof.

The severing means may be rotatably mounted on the lid.

The formation on the lid may be arranged to hold the storage bag against the waste inlet aperture in the closed position.

25 The storage bag may be formed from a length of flexible tubing drawn from a pack as waste is thrust through the waste inlet aperture, the pack being rotatable relative to the main body to form a closure about the waste by twisting.

According to the invention there is further provided a method of storing waste in a waste storage device as claimed in any preceding claim in which a waste storage bag is positioned extending through the waste inlet aperture, the method comprising the steps of opening the lid, placing waste in the storage bag and closing the lid, in which, when it is desired to sever the storage bag the severing means is moved relative to the lid and the bag to sever the bag.

According to the invention there is yet further provided a waste storage device comprising a main body and a lid, the main body including a waste aperture inlet arranged to receive a storage bag, the waste aperture inlet including an outwardly flared portion and the lid being hinged to the main body between an open position and a closed position enclosing the outwardly flared portion of the waste aperture inlet.

An embodiment of the invention will now be described, by way of example, with reference to the drawings, of which:

- 15 Fig. 1 is a partially cut-away side view of a device of known type;
Fig. 2 is a partial sectional side view of another device of known type;
Fig. 3 is an underneath plan view of a cutting device of known type;
Fig. 4 is a perspective view of an embodiment of the invention in a first configuration;
- 20 Fig. 5a is a sectional perspective view of a detail of the embodiment of Fig. 4 at a first stage of operation;
Fig. 5b is a partial perspective view corresponding to Fig. 5a;
Fig. 6a is a sectional perspective view of a detail of the embodiment of Fig. 4 at a second stage of operation;
- 25 Fig. 6b is a partial perspective view corresponding to Fig. 6a;
Fig. 7a is a perspective view of the embodiment of Fig. 4 in a second configuration; and

Fig. 7b is a sectional view corresponding to Fig. 7a.

Referring now to Figs. 4 to 7, an embodiment of the invention is now described in more detail. Features common with the embodiments described with reference to Figs. 1 to 3 are referenced with like numerals and their description will not be repeated except where necessary.

The device comprises a plastics container 21 generally corresponding to that shown in Figs. 1 to 3, in particular including a pack from which flexible tubing can be drawn out, and springs for holding an object against twisting to form a series of packages separated by twisted closures. A funnel 12 is detachably fixed to the pack as discussed in relation to Fig. 3. The container 21 hinges intermediate its top and bottom allowing it to be opened to remove waste -- a releasable catch 80 is preferably provided allowing the container to be held closed in general use. The container may, alternatively, open at its base in a known manner.

The device further includes a lid 70 on which a severing arrangement or cutter assembly designated generally as 72 is mounted. The lid 70 is hinged to the container 21 by a hinge mechanism of any suitable type, and may be permanently or detachably fixed by the hinge. The lid is preferably also of plastics material.

The severing arrangement 72 is best understood with reference to Figs. 5, 6 and 7b. The arrangement includes a ring 74 which is rotatably mounted on the lid 70 and received in a cylindrical flange 71 moulded integrally with the lid 70. The ring 74 is snap fitted onto the lid 70 and held in place, but free to rotate, in a keyway channel, such that an annular ridge projecting from the ring 74 is received in a cooperating circumferential channel in the flange 71. The ring 74 further includes inwardly radially projecting finger pieces 75 allowing manual rotation of

the ring. Alternatively, as shown in, for example, Fig. 7a, a central cross bar 77 may be provided across the ring 74 for manual rotation.

Projecting from the underside of the ring 74 is a cutter unit 61 including a tapered shoe and cutter blade, of the type described in relation to Fig. 3 above.

5 The arrangement further includes a tamper-proof catch or detent means 76 arranged to releasably fix the ring 74 against rotation. In the embodiment shown the catch 76 includes a resilient tab 78 attached at its lower end to the lid 70 and having a tongue 80 projecting from its upper end. The tab 78 can be integrally moulded with the lid 70, or flexibly mounted in any suitable manner. The tab 78
10 is biased radially inwardly into engagement with the periphery of the ring 74 and the ring 74 includes one or more indents 82 around its periphery arranged to engage with the tongue 80 and hold the ring 74 against rotation. The tab 78 includes a pressure portion 84 extending generally away from the ring 74. When manual pressure is applied to the pressure portion 84 the tab 78 flexes outwardly
15 away from the ring 74, the tongue 80 disengages the indent 82 and the ring can be rotated. Once the catch 76 is released, the ring is free to rotate until the tongue 80 slips into the next indent 82 under the bias of the tab 78.

The lid 70 and severing arrangement 72 are generally configured such that when the lid 70 is hinged to its closed position the cylindrical flange 71 engages
20 the inside of the funnel as a taper fit. The lid 70 is also of sufficient dimension to enclose the whole of the funnel 12 in its closed position. The lid 70 can be held in the closed position by suitable detent means 86, releasable to allow the lid 70 to be opened. As a result the whole of the inside of the device can be closed off in a secure and tamper proof manner.

25 In operation, when it is desired to place an object in the device, the lid 70 is hinged open, the object is pushed down into engagement with the springs 52 and the funnel 12 is twisted to form a twisted closure 30 as described above with

reference to Figs. 1 to 3; in particular forming a cone of flexible tubing. The lid 70 is then closed and the flange 71 locks into engagement with the inside of the funnel 12, securely closing the device against the escape of odours. The flexible tubing is held captive between the flange 71 and the funnel 12 and is also held taut
5 by virtue of the engagement of the package 35 with the springs 52.

When it is desired to sever the flexible tubing, the catch 76 is depressed to release the ring 74, and the ring 74 is rotated by manual pressure applied to the finger pieces 75. The cutter unit then operates as discussed in relation to Figs. 1 to 3 above, the cutter engaging with a crease in the flexible tubing cone, feeding the
10 tubing to the knife edge and severing it, the flange 71 holding the funnel, and hence the pack, against rotation. When the tubing has been severed the catch 76 is released and the ring 74 is further rotated until the tongue 80 slips into engagement with the next indent 82.

As a result an improved waste storage system is provided. Because the
15 severing arrangement is mounted in a lid attached to the main body, there is no risk that it might be misplaced. Positioning of the severing arrangement is made simple as it is automatically located as the lid is hinged closed by the taper fit of the surrounding cylindrical flange with the inside of the funnel, and the number of steps in the cutting operation is reduced. Operation of the severing arrangement is
20 simplified as it is not necessary to hold manually the pack itself against rotation - this is achieved automatically by the fixed lid engaging the pack. Furthermore the severing step is carried out entirely hygienically as the whole of the interior of the waste storage device is closed off by the lid.

Referring once again to Fig. 4, according to which the container 21
25 comprises an upper part 83 and a lower part 85 held together by a catch 81 and any suitable detachable hinge means (not shown), a modular waste storage device is also provided. In particular it will be noted that the upper portion 83 of the

container 21 includes all of the working parts of the device including the cassette 2, springs 52, lid 70 and severing arrangement 72. Accordingly it is possible to use the device in modular form according to which the upper portion 83 can be attached to any suitable lower part. For example a larger bin-type lower part can be provided for commercial requirements in which large amounts of waste are required to be stored. Alternatively the upper portion 83 can be connected, for example, to a work surface having a suitable aperture for receiving waste.

It will be appreciated that the invention may be applied to alternative waste disposal device configurations - for example without any funnel in place or an arrangement such as that set out in International Patent Application No. PCT/GB97/02768 including an additional collector bag for receiving the individual packages 35.. The specific details of the cutting unit can of course be varied as appropriate. The lid need not be hinged but can be movably fixed to the container in any other appropriate manner.

15

CLAIMS

1. A waste storage device comprising a main body and a lid, the main body
5 including a waste aperture inlet arranged to receive a storage bag, the lid
comprising storage bag severing means movably mounted thereon and a
formation arranged to hold the storage bag against movement relative to the lid
when the lid is in a closed position, for operation of the severing means, in which
the lid is movably fastened to the main body between said closed position and an
10 open position.
2. A waste storage device as claimed in claim 1 in which the lid is guided
between said open and closed positions by the movable fastening.
- 15 3. A waste storage device as claimed in claim 2 in which the lid is hinged to
the main body.
4. A waste storage device as claimed in any preceding claim in which the
waste inlet aperture includes an outwardly flared upper end enclosed by the lid in
20 the closed position.
5. A waste storage device as claimed in any preceding claim in which the lid
further includes detent means releasably fixing the severing means against
movement relative to the lid.
- 25 6. A waste storage device as claimed in any preceding claim in which the
severing means is rotatably mounted on the lid.

7. A waste storage device as claimed in any preceding claim in which the formation on the lid is arranged to hold the storage bag against the waste inlet aperture in the closed position.
- 5
8. A waste storage device as claimed in any preceding claim in which the storage bag is formed from a length of flexible tubing drawn from a pack as waste is thrust through the waste inlet aperture, the pack being rotatable relative to the main body to form a closure about the waste by twisting.
- 10
9. A method of storing waste in a waste storage device as claimed in any preceding claim in which a waste storage bag is positioned extending through the waste inlet aperture, the method comprising the steps of opening the lid, placing waste in the storage bag and closing the lid, in which, when it is desired to sever the storage bag the severing means is moved relative to the lid and the bag to sever the bag.
- 15
10. A waste storage device comprising a main body and a lid, the main body including a waste aperture inlet arranged to receive a storage bag, the waste aperture inlet including an outwardly flared portion and the lid being hinged to the main body between an open position and a closed position enclosing the outwardly flared portion of the waste aperture inlet.
- 20
11. A waste storage device substantially as herein described and as illustrated by Figs. 4 to 7 of the drawings.
- 25

12. A method of storing waste substantially as herein described and as illustrated by Figs. 4 to 7 of the drawings.

5 13. A modular waste storage device comprising a body portion including a waste inlet aperture, means for receiving a storage bag provided below the waste inlet aperture and fixing means for fixing the main body to a waste receptacle.

10 14. A waste storage device as claimed in claim 13 in which the storage bag is feedable from a cassette in the storage bag receiving means and the main body further includes means for closing the storage bag around waste to be stored.

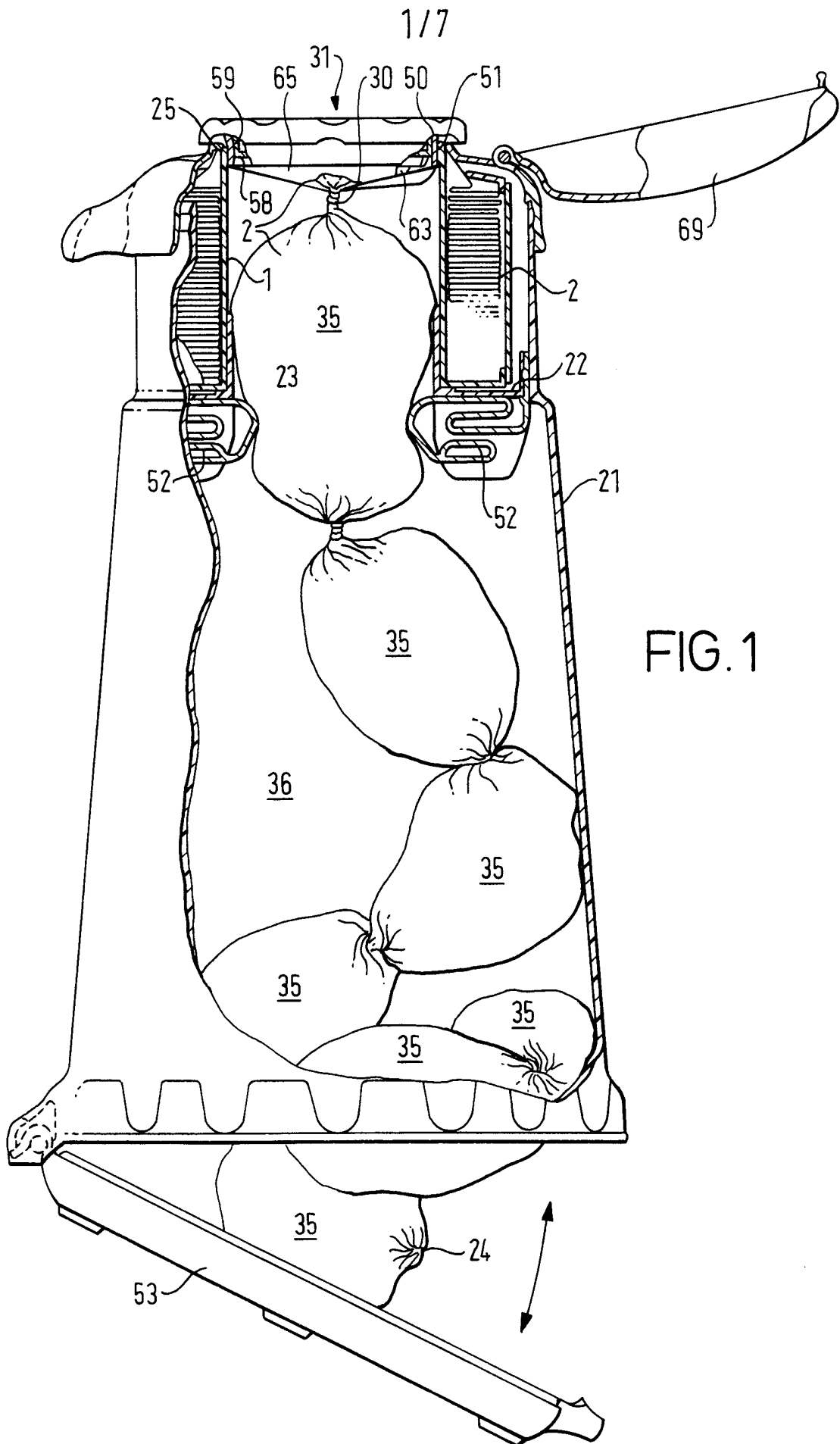

FIG. 1

217

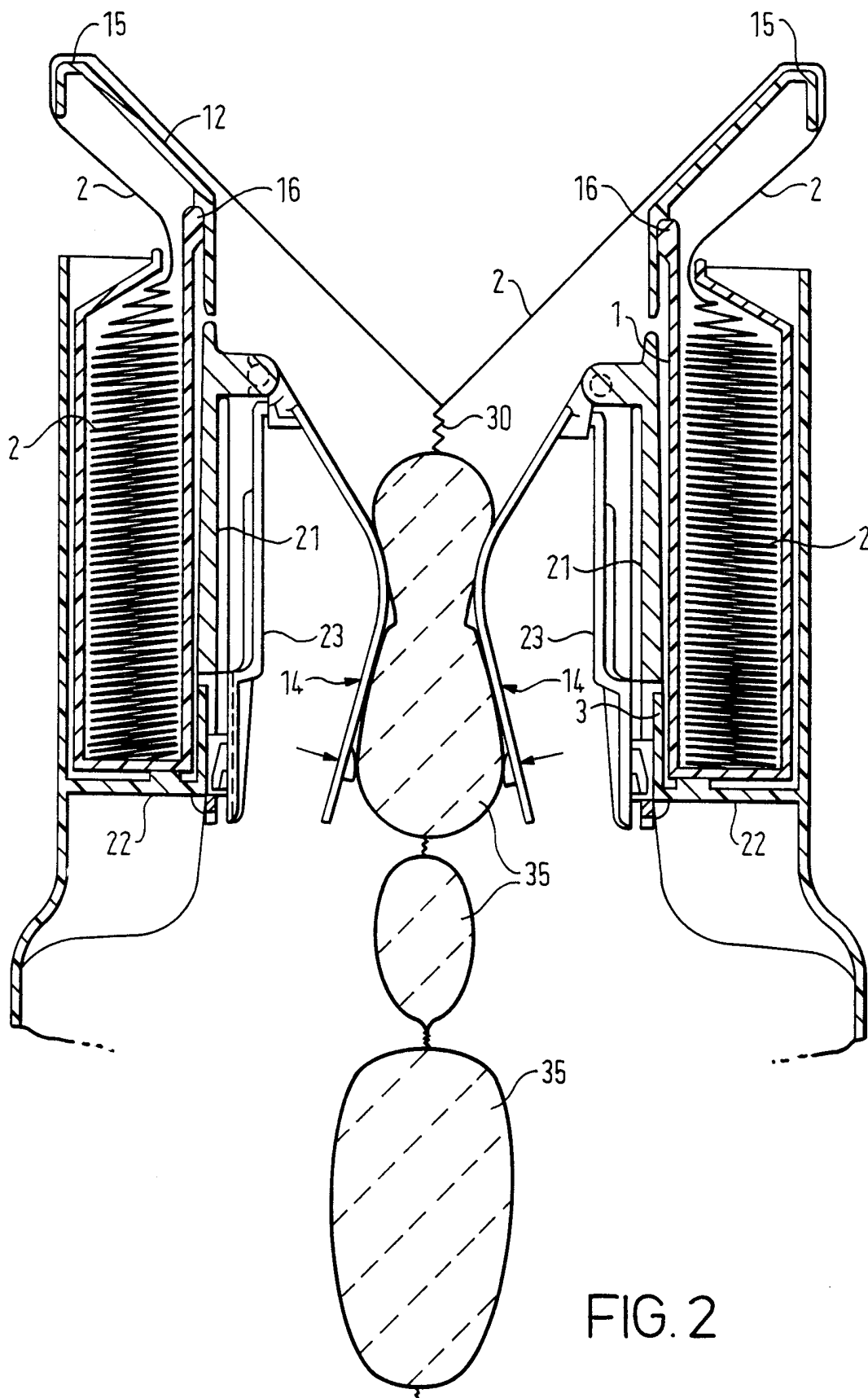

FIG. 2

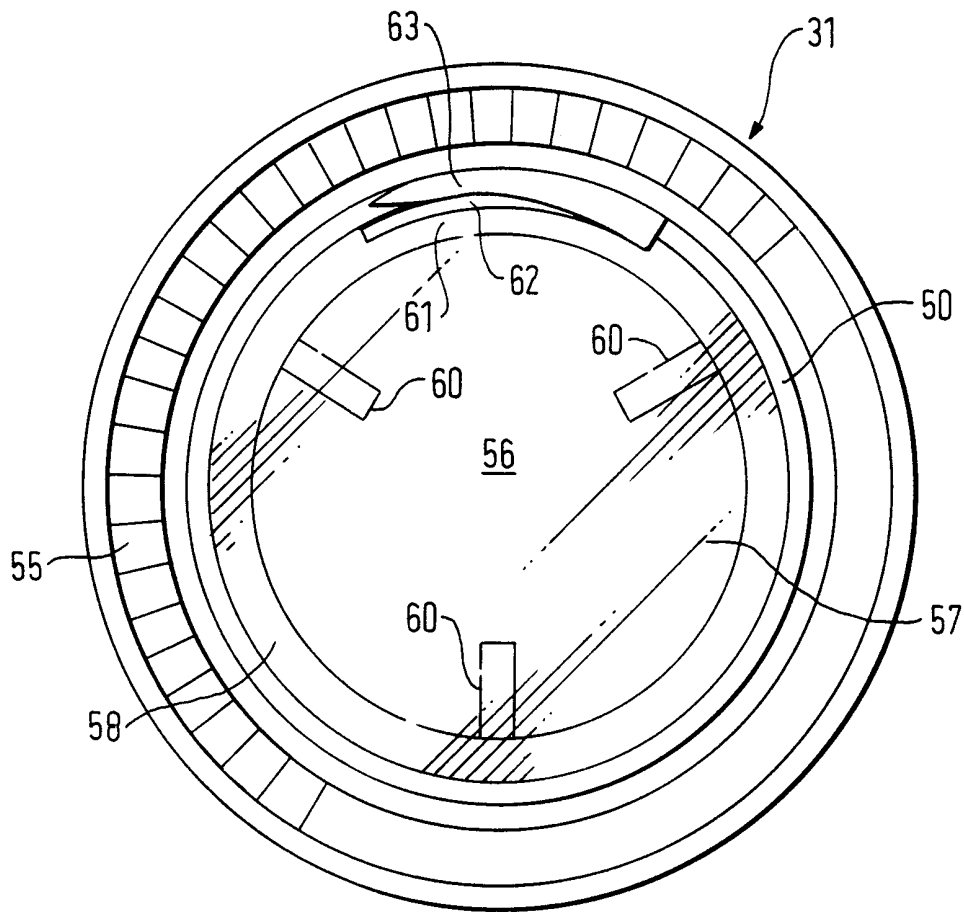
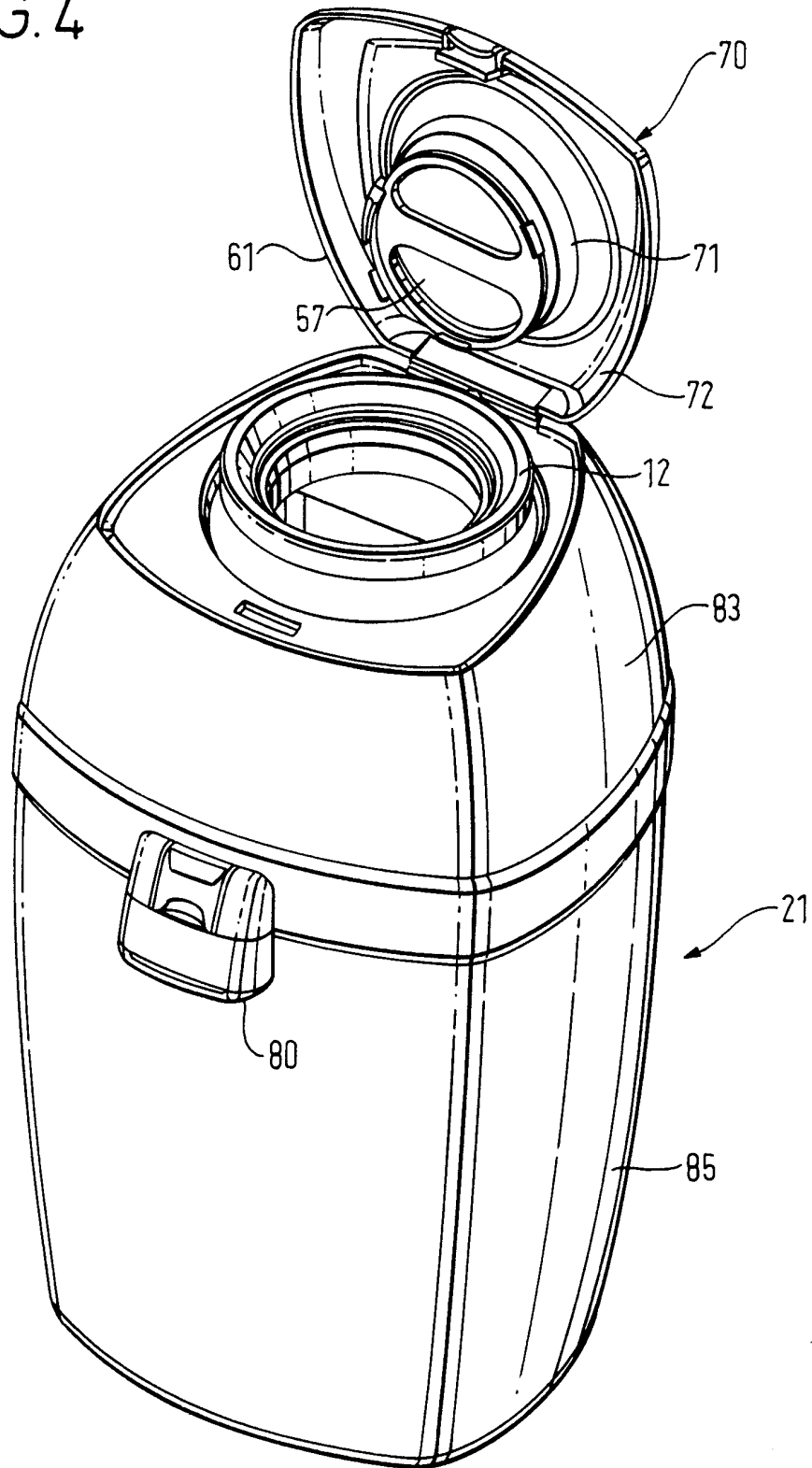

FIG. 3

FIG. 4



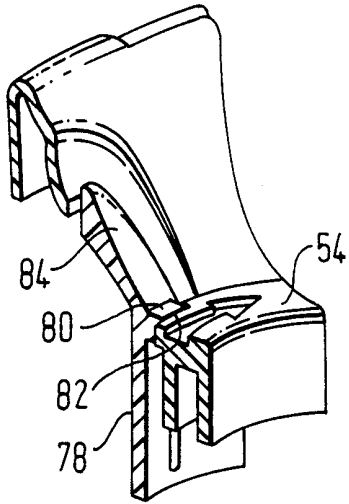

FIG. 5a

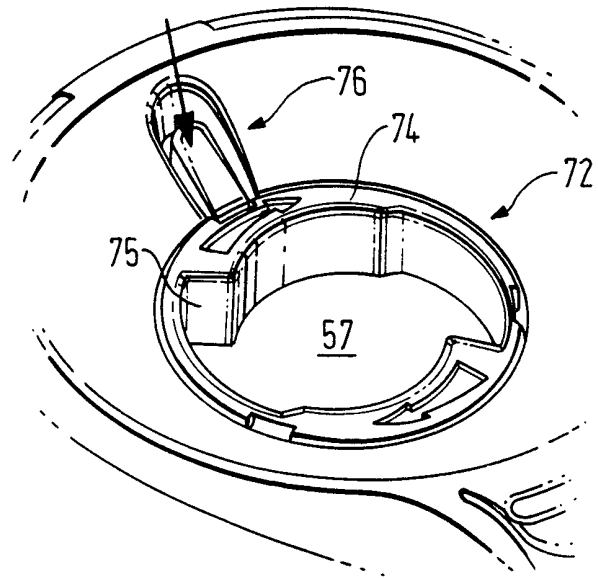

FIG. 5b

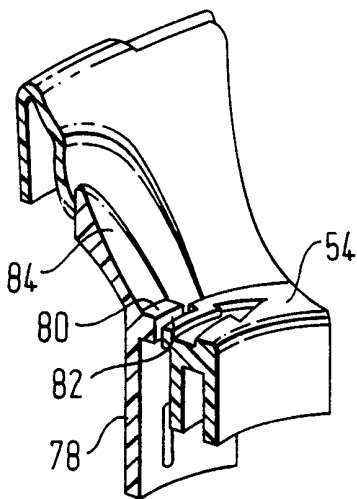

FIG. 6a

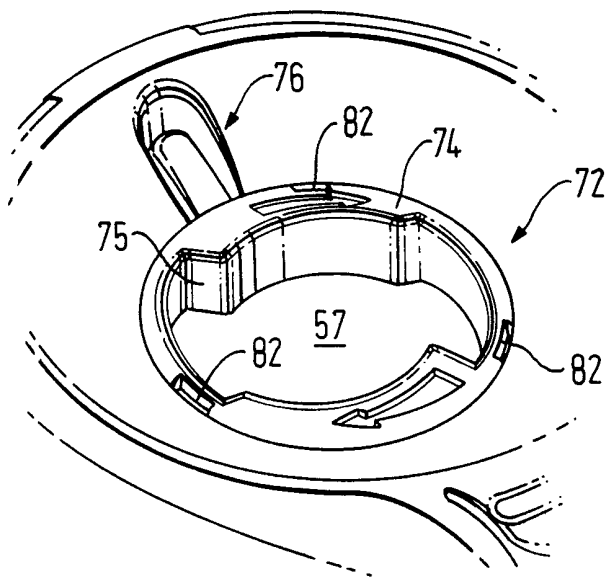

FIG. 6b

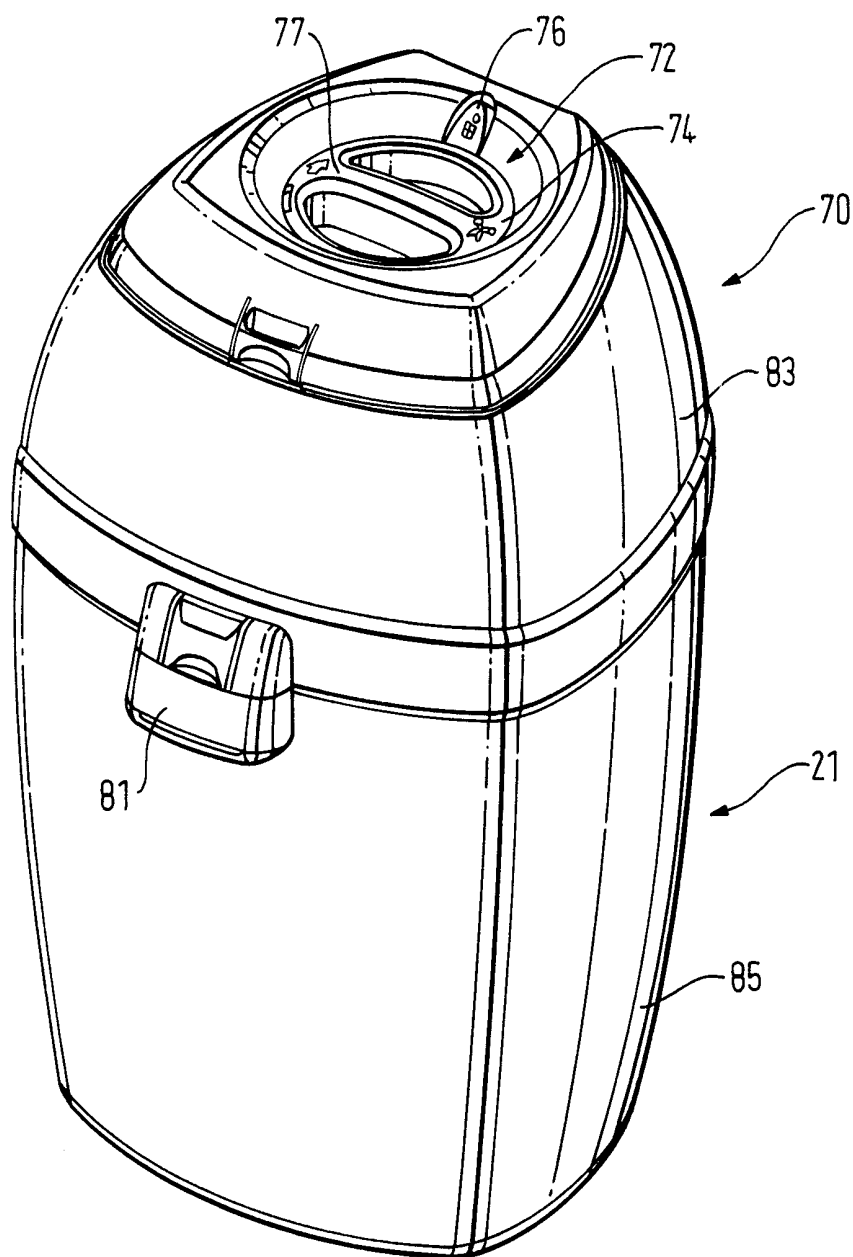

FIG. 7a

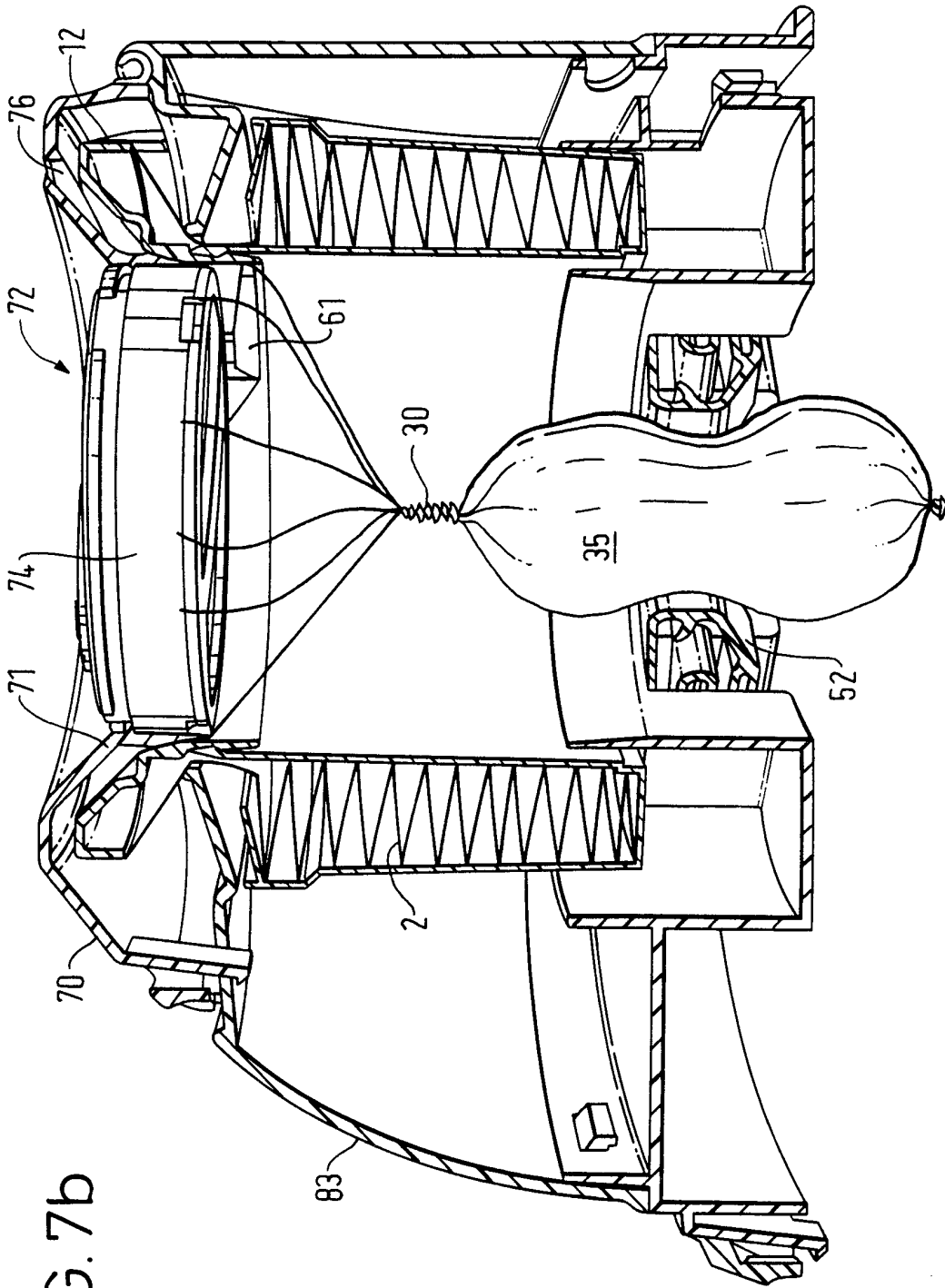

FIG. 7b

INTERNATIONAL SEARCH REPORT

International Application No

PCT/GB 99/00243

A. CLASSIFICATION OF SUBJECT MATTER
 IPC 6 B65F1/06 B65F1/16

According to International Patent Classification (IPC) or to both national classification and IPC

B. FIELDS SEARCHED

Minimum documentation searched (classification system followed by classification symbols)

IPC 6 B65F B65B A47K

Documentation searched other than minimum documentation to the extent that such documents are included in the fields searched

Electronic data base consulted during the international search (name of data base and, where practical, search terms used)

C. DOCUMENTS CONSIDERED TO BE RELEVANT

Category	Citation of document, with indication, where appropriate, of the relevant passages	Relevant to claim No.
Y	DE 93 19 683 U (J. KRETH ET AL.) 28 April 1994 see page 7, line 13 - page 10, line 31 see figures 1,2 ---	1-4,6-10
Y	DE 31 28 075 A (GLÖRFELD GMBH) 27 January 1983 see page 9, line 1 - line 14 see figure ---	1-4,6-10
X A	US 3 452 368 A (J. COUPER) 1 July 1969 see column 2, line 57 - column 4, line 65 see figures 1,2 ---	13,14 1,9,10
A	GB 2 206 094 A (PROCESS IMPROVEMENTS LTD) 29 December 1988 cited in the application see the whole document ---	1,9,10, 13
-/--		

Further documents are listed in the continuation of box C.

Patent family members are listed in annex.

Special categories of cited documents:

"A" document defining the general state of the art which is not considered to be of particular relevance

"E" earlier document but published on or after the international filing date

"L" document which may throw doubts on priority claim(s) or which is cited to establish the publication date of another citation or other special reason (as specified)

"O" document referring to an oral disclosure, use, exhibition or other means

"P" document published prior to the international filing date but later than the priority date claimed

"T" later document published after the international filing date or priority date and not in conflict with the application but cited to understand the principle or theory underlying the invention

"X" document of particular relevance; the claimed invention cannot be considered novel or cannot be considered to involve an inventive step when the document is taken alone

"Y" document of particular relevance; the claimed invention cannot be considered to involve an inventive step when the document is combined with one or more other such documents, such combination being obvious to a person skilled in the art.

"&" document member of the same patent family

Date of the actual completion of the international search

29 April 1999

Date of mailing of the international search report

21 May 1999 (21.05.99)

Name and mailing address of the ISA

European Patent Office, P.B. 5818 Patentlaan 2
 NL - 2280 HV Rijswijk
 Tel. (+31-70) 340-2040, Tx. 31 651 epo nl,
 Fax: (+31-70) 340-3016

Authorized officer

Smolders, R

INTERNATIONAL SEARCH REPORT

International Application No

PCT/GB 99/00243

C.(Continuation) DOCUMENTS CONSIDERED TO BE RELEVANT		
Category *	Citation of document, with indication, where appropriate, of the relevant passages	Relevant to claim No.
A	GB 2 292 725 A (PROCESS IMPROVENTS LTD) 6 March 1996 cited in the application see the whole document -----	1,9,10, 13

INTERNATIONAL SEARCH REPORT

International application No.

PCT/GB 99/00243

Box I Observations where certain claims were found unsearchable (Continuation of item 1 of first sheet)

This International Search Report has not been established in respect of certain claims under Article 17(2)(a) for the following reasons:

1. Claims Nos.: 11, 12
because they relate to subject matter not required to be searched by this Authority, namely:
Rule 6.2a

2. Claims Nos.:
because they relate to parts of the International Application that do not comply with the prescribed requirements to such an extent that no meaningful International Search can be carried out, specifically:

3. Claims Nos.:
because they are dependent claims and are not drafted in accordance with the second and third sentences of Rule 6.4(a).

Box II Observations where unity of invention is lacking (Continuation of item 2 of first sheet)

This International Searching Authority found multiple inventions in this international application, as follows:

see additional sheet

1. As all required additional search fees were timely paid by the applicant, this International Search Report covers all searchable claims.

2. As all searchable claims could be searched without effort justifying an additional fee, this Authority did not invite payment of any additional fee.

3. As only some of the required additional search fees were timely paid by the applicant, this International Search Report covers only those claims for which fees were paid, specifically claims Nos.:

4. No required additional search fees were timely paid by the applicant. Consequently, this International Search Report is restricted to the invention first mentioned in the claims; it is covered by claims Nos.:

Remark on Protest

- The additional search fees were accompanied by the applicant's protest.
- No protest accompanied the payment of additional search fees.

INTERNATIONAL SEARCH REPORT

International Application No. PCT/GB 99 00243

FURTHER INFORMATION CONTINUED FROM PCT/ISA/ 210

This International Searching Authority found multiple (groups of) inventions in this international application, as follows:

1. Claims: 1-9

Waste storage device and method of storing waste in a waste storage device whereby the waste storage device comprises severing means for a storage bag.

2. Claim : 10

Waste storage device comprising an outwardly flared portion.

3. Claims: 13,14

Waste storage device being modular.

INTERNATIONAL SEARCH REPORT

Information on patent family members

International Application No

PCT/GB 99/00243

Patent document cited in search report	Publication date	Patent family member(s)	Publication date
DE 9319683	U	28-04-1994	NONE

DE 3128075	A	27-01-1983	NONE

US 3452368	A	01-07-1969	NONE

GB 2206094	A	29-12-1988	AT 93795 T 15-09-1993
			AU 602192 B 04-10-1990
			AU 1237388 A 08-09-1988
			CA 1298191 A 31-03-1992
			DE 3883560 D 07-10-1993
			DE 3883560 T 17-02-1994
			EP 0281355 A 07-09-1988
			ES 2042732 T 16-12-1993
			JP 1226601 A 11-09-1989
			JP 2543562 B 16-10-1996
			US 4869049 A 26-09-1989

GB 2292725	A	06-03-1996	CA 2156962 A 27-02-1996
			EP 0699584 A 06-03-1996
			JP 2831599 B 02-12-1998
			JP 8175603 A 09-07-1996
			US 5590512 A 07-01-1997
