

(No Model.)

2 Sheets—Sheet 1.

J. W. ROBERTS.  
CAN TESTING APPARATUS.

No. 423,083.

Patented Mar. 11, 1890.

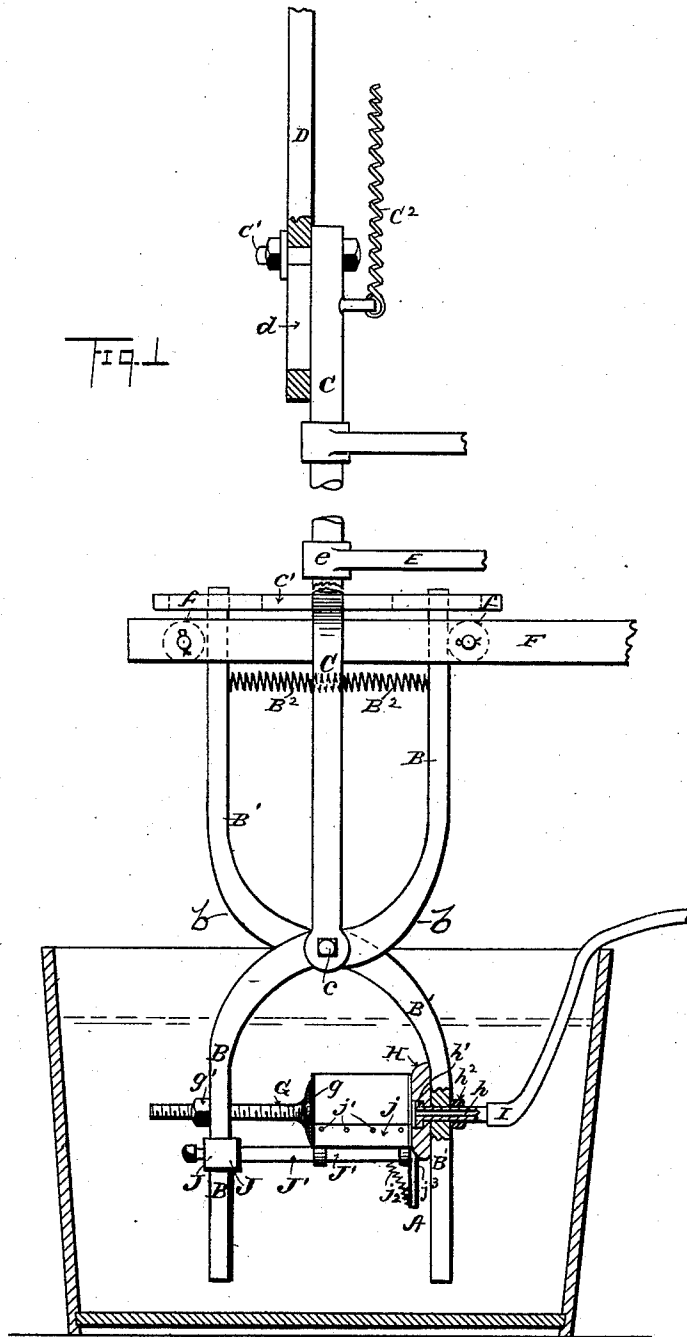

WITNESSES  
*Belle S. Loomis*  
*Chas. B. Sage*

INVENTOR  
*John W. Roberts*  
*Leggett and Leggett.*  
ATTORNEYS

(No Model.)

2 Sheets—Sheet 2.

J. W. ROBERTS.  
CAN TESTING APPARATUS.

No. 423,083.

Patented Mar. 11, 1890.

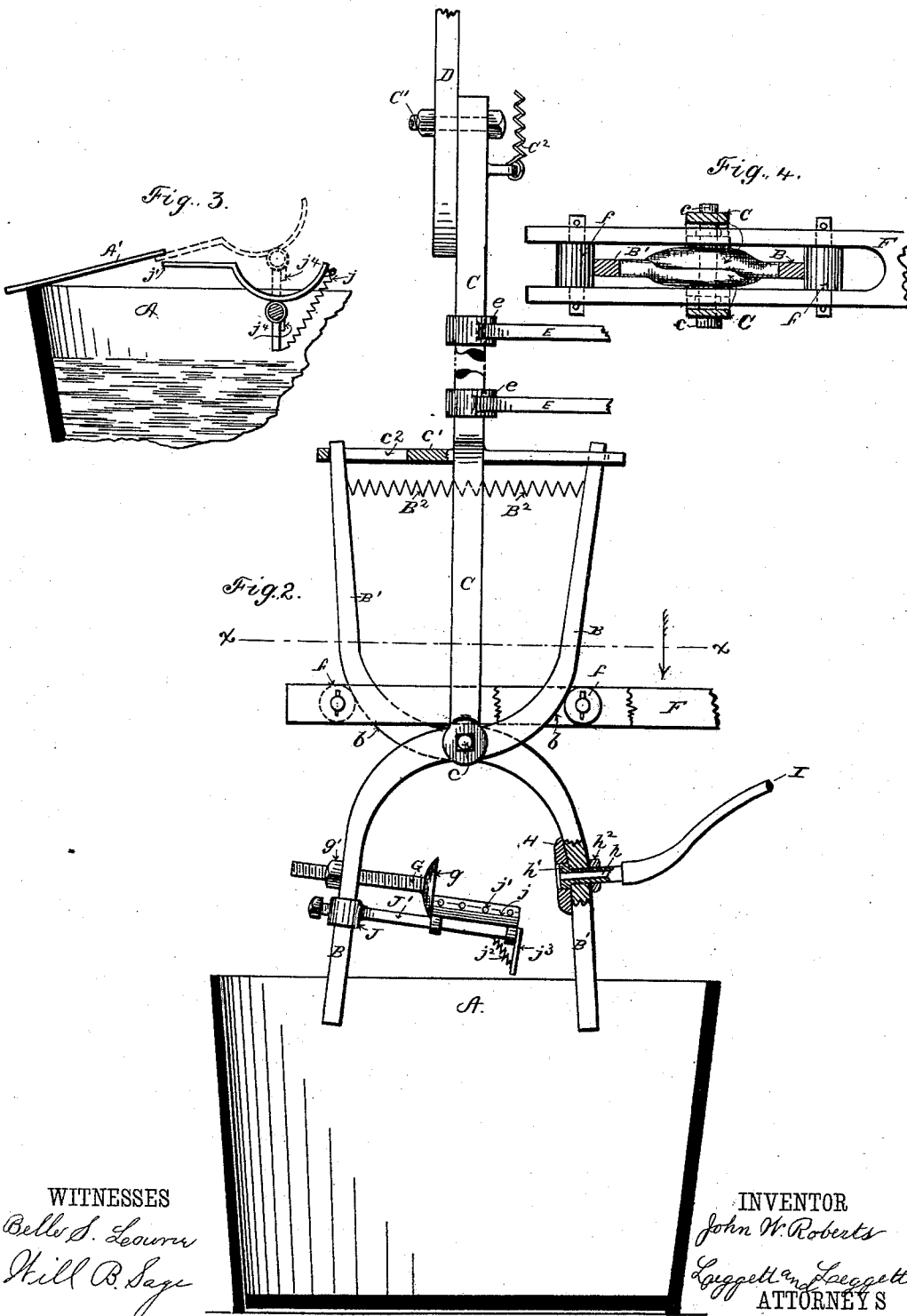

WITNESSES

*Belle S. Loun*  
*Hill B. Sage*

INVENTOR

*John W. Roberts*

*Leggett and Leggett*  
ATTORNEYS

# UNITED STATES PATENT OFFICE.

JOHN W. ROBERTS, OF CLEVELAND, OHIO, ASSIGNOR OF ONE-HALF TO THE  
SHERWIN-WILLIAMS COMPANY, OF SAME PLACE.

## CAN-TESTING APPARATUS.

SPECIFICATION forming part of Letters Patent No. 423,083, dated March 11, 1890.

Application filed November 18, 1889. Serial No. 330,701. (No model.)

*To all whom it may concern:*

Be it known that I, JOHN W. ROBERTS, of Cleveland, in the county of Cuyahoga and State of Ohio, have invented certain new and useful Improvements in Can-Testing Apparatus; and I do hereby declare the following to be a full, clear, and exact description of the invention, such as will enable others skilled in the art to which it pertains to make and use the same.

My invention relates to improvements in apparatus for testing cans.

In the manufacture of metal cans, and before the can has been sealed or filled, it has been customary to test the can, under water with compressed air, and any leakage of the can was indicated by bubbles of air rising to the surface of the water.

The object of my invention is to provide improved apparatus for accomplishing the result; and it consists in certain features of construction and combination of parts, as will be more fully explained, and pointed out in the claims.

In the accompanying drawings, Figures 1 and 2 are corresponding side elevations, partly in section, showing different working positions. Fig. 3 is an end view of the can-support or tilting table. Fig. 4 is a plan in section on line *x x*, Fig. 2.

A represents a tank nearly filled with water or other fluid, in which the can is tested, and A' is an apron extending inward over the edge of the tank for receiving the perfect can discharged from the apparatus, these cans rolling down the incline of the apron and falling into a box, crate, or other receptacle. Tongs are provided for holding and hermetically sealing the can during the testing.

B B' are the levers of the tongs, pivoted together at the crossing at *c* to and between the prongs of the forked lower end of upright intermittingly-reciprocating rod C. The rod C is provided with a wrist C', that operates in slot *d* of pitman D, this pitman connecting with a crank (not shown) for operating the same. Brackets E E are provided with heads *e e* for embracing the rod C, thereby serving as guides for the latter, these brackets being secured to a post, wall, or any stationary support. A stationary bracket F, lo-

ated as shown, is slotted at the free end thereof, the prongs of the bracket extending astride the upper section of the tongs, roller *f* being located between the prongs in position to engage the outer edges of the opposing sections of the tongs, the trunnions or axial pins of the rollers being journaled in lateral holes of the bracket. A spring B<sup>2</sup> bears against the levers B B', this spring acting outwardly to open the tongs, and hence acting in opposition to the rollers *f*. I may here remark that the spring and rollers might be reversed—that is to say, the rollers might be placed on the inside of the tongs to open the latter, with the spring arranged to close the tongs—although for various reasons the arrangement shown is preferable. The upper sections of the tongs levers are intended to be straight and parallel with each other when the tongs are in position closed upon the can, and hence the tongs remain closed so long as the straight portions thereof engage the rollers *f*, the opening of the tongs occurring near the ends of the upstrokes, where the inclines or curves *b b* of the tongs engage the rollers *f*, and the tongs are closed during the first part of the downstroke.

Connected with the rod C is a cross-head *c'*, with slots *c<sup>2</sup>*, in which the upper sections of the tongs operate, the outer end wall of these slots serving as stops to limit the opening of the tongs. A spring C<sup>2</sup> is connected with the rod C and with the ceiling; or, in place of such spring, a cord, belt, or chain running over a loose pulley having a weight attached counterbalances the rod C and attachment, so that this mechanism will remain stationary, except as it is actuated by the pitman D aforesaid, and hence by reason of the lost motion had by means of wrist C', operating in the slot *d* of the pitman, the tongs remain for a time stationary both at the upper and the lower extremes of the throw. During the moment of rest below the can is filled with compressed air, and in case the can is defective bubbles of air appear at the surface of the water. During the moment of rest above the operator removes the tested can and supplies another can to be tested. Lever B, below the fulcrum thereof, has a screw-threaded hole for engaging the screw-thread-

ed rod G, this rod being provided with a head or disk *g* for engaging the head of the can. The rod is provided with a jam-nut *g'*, by tightening which the rod is held in adjustment. By loosening the nut *g'* the rod G may be turned with the fingers to adjust the rod lengthwise, according to the length of the can.

Connected with the member B' of the tongs, and opposite the head *g*, is located a rubber disk H, the same having usually rounded edges, and being adapted to fit and hermetically close the open end of the can. This rubber disk is secured to the member B' by means of a tube *h*, the latter extending through holes in the disk and tongs, this tube having a nut or head *h'*, engaging the face of the rubber disk, and having a nut *h<sup>2</sup>*, engaging the back side of the tongs. By tightening the nut *h<sup>2</sup>* the nut or head *h'* is sunk into the rubber disk about flush with the face thereof, so that this nut or head *h'* is out of the way in placing the can. To the outer end of tube *h* is attached a flexible tube I, through which the compressed air is supplied under a pressure of perhaps four or five pounds (more or less) to the square inch. An ordinary fan-blower or an air-compressor of about any kind will furnish such compressed air.

J is a head adapted to slide on the member B of the tongs, this head being held in position by a set-screw, so that it may be adjusted lengthwise of member B. Head J is provided with a rod J', extending toward member B'. On rod J' is pivotally mounted a small plate *j*, this plate serving as a rest or table for receiving the can in position to be engaged by the tongs. The edges of this plate are curved upward, so as to approximately fit the can.

From the one edge of plate *j* that is opposite apron A' project fingers *j'*, these fingers consisting usually of wires or small rods that will cause but little agitation in the water. These fingers extend under and engage the apron during the latter part of the upstroke of the tongs, by which engagement the table *j* is tilted toward the apron, such tilting not being quite enough to discharge the can. If the can has been found perfect, it is displaced by a mere touch of the succeeding can that is being placed in position in the tongs, in which case the tested can rolls down the fingers and apron. In case the tested can has proved imperfect, the operator removes it from the table with one hand, while he places another can in position with the other hand, and the operator usually retains his hold of the can placed on the table until the table is righted and the tongs have grasped the can,

and this will occur of course on the first part of the downward movement of the tongs.

For righting or returning table *j* to its normal or horizontal position, spring *j<sup>2</sup>* is provided, this spring being connected with the one side of the table and with an arm *j<sup>3</sup>*, depending from the rod J'. A lug *j<sup>4</sup>*, attached to the table, by engaging the rod *j<sup>3</sup>*, serves as a stop for the table when the latter reaches its normal or horizontal position.

The machine is speeded to the capacity of the operator in supplying the cans, and with this machine the same operator would probably test two or three times as many cans as with the hand apparatus heretofore employed.

The air-supply pipe may be provided with a valve operated automatically from the machine for closing the pipe during the time that the can is above water; but the waste of air is not considered of sufficient importance to warrant even a small outlay for such purpose.

What I claim is—

1. Can-testing apparatus comprising tongs adapted to grasp the can and hermetically close the open end thereof, the tongs having reciprocating movement endwise, rollers, and springs acting on the tongs in opposition to each other for opening and closing the tongs with the reciprocations of the latter, substantially as set forth.

2. Can-testing apparatus comprising tongs for grasping and closing the can, such tongs having reciprocating movement endwise, with mechanism for opening and closing the tongs with the reciprocations thereof, substantially as indicated, and an air-tube connected with one member of the tongs for supplying air to the can, substantially as set forth.

3. In can-testing apparatus, the combination, with tongs, substantially as indicated, such tongs having intermittent reciprocating end movement, of rollers and springs acting on the tongs in opposition to each other for opening and closing the tongs with the reciprocations of the latter, substantially as set forth.

4. The combination, with tongs and mechanism for endwise reciprocating and opening and closing the tongs, substantially as indicated, of a tilting table connected with the one member of the tongs in position to receive the cans, substantially as set forth.

In testimony whereof I sign this specification, in the presence of two witnesses, this 30th day of August, 1889.

JOHN W. ROBERTS.

Witnesses:

C. H. DORER,  
ALBERT E. LYNCH.