

Jan. 2, 1923.

1,441,046.

C. E. VANCE ET AL.

STEAM TRAP.

FILED JULY 20, 1921.

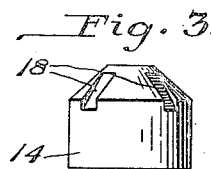
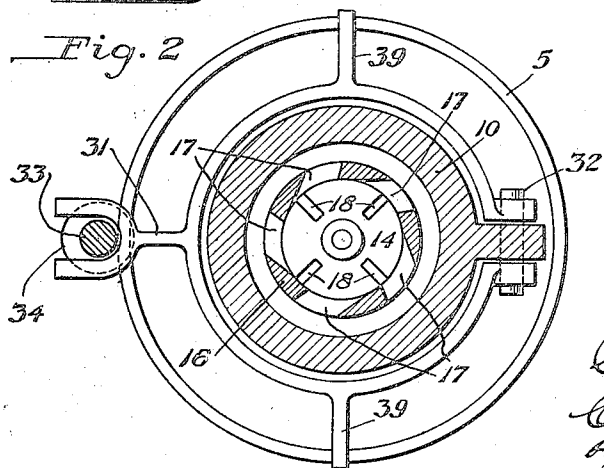
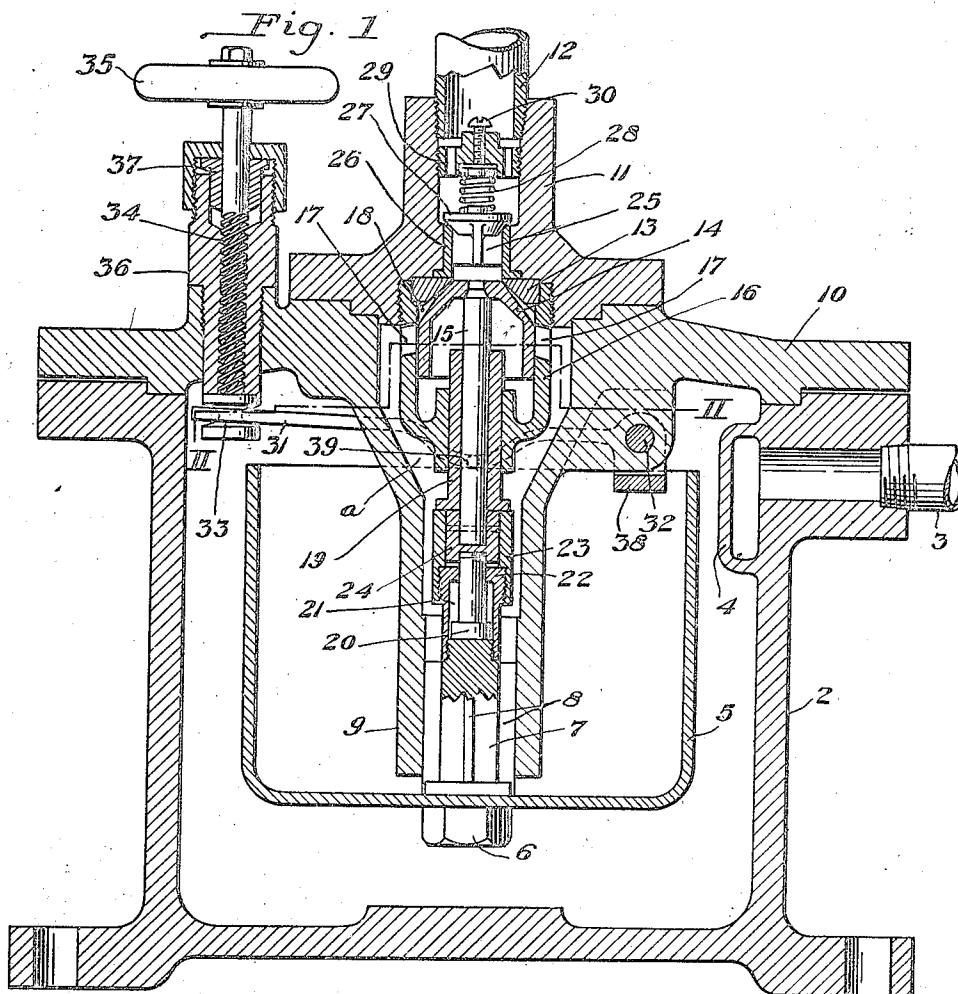

INVENTORS.

Charles E. Vance  
Charles S. McClelland  
by C. M. Clark atty

## UNITED STATES PATENT OFFICE.

CHARLES E. VANCE AND CHARLES S. McCLELLAND, OF PITTSBURGH, PENNSYLVANIA.

## STEAM TRAP.

Application filed July 20, 1921. Serial No. 486,050.

*To all whom it may concern:*

Be it known that we, CHARLES E. VANCE and CHARLES S. McCLELLAND, citizens of the United States, residing at Pittsburgh, in the county of Allegheny and State of Pennsylvania, have invented certain new and useful Improvements in Steam Traps, of which the following is a specification.

Our invention relates to improvements in steam traps for the purpose of collecting water of condensation in a steam line and blowing it out from time to time. It has in view to provide improved means for effectually unseating the outlet valve, means for maintaining the valve stem and its parts in alinement, means for intermittently rotating the outlet valve, and other features of improvement, as shall be more fully hereinafter described.

The present invention is an improvement in the steam trap of prior Patent No. 847,131, of March 12, 1907, to C. E. Vance, to which it is generally similar in the main construction.

In the drawings:

Fig. 1 is a central vertical section through the trap, showing it empty;

Fig. 2 is a cross section on the line II—II of Fig. 1;

Fig. 3 is a detail view of the outlet sealing valve.

In the drawings, 2 is the main casing having connection at 3 with a steam line delivery water of condensation into the interior of casing 2, and against and around a baffle 4. A bucket 5 is fixedly secured by nut 6 to the lower end of a stem 7 having guiding wings 8 engaging the interior of a tubular extension 9 of the casing top 10. A supplemental top 11 is provided with a central hollow outlet opening connected with a discharge pipe 12, and within top 11 is an inserted valve seat 13 for making sealing engagement with a valve 14 having a central stem 15. Valve 14 is freely rotatable, either upon stem 15, or with the stem, by suitable mounting thereof, but so arranged that the valve will be thrust upwardly by upward movement of the stem, or when the stem is retracted, the valve may recede for outward passage of water or steam.

A surrounding cage 16 cylindrically embraces valve 14 for longitudinal movement thereof, and cage 16 is secured by threads in the cap 11. It is provided with a series

of tangential openings 17 through which the outgoing water and steam pass, and valve 14 has a series of radial slots or wing faces 18 across its outer seat portion and in the path of the tangential slot currents. By this means, a partial rotation of valve 14 is effected at each operation, thereby keeping the valve and seat clean and unobstructed, and giving it a slight grinding action.

A guiding tube or bushing 19 for stem 15 is held in the lower part of cage 16 within which the stem has a limited rising and falling movement, and the lower end of the stem has a head 20 which in turn has a limited range of movement in cavity 21 of bucket stem 7 and against a limiting shoulder 22 thereof. A guiding sleeve 23 extends upwardly from stem 7 and slidably embraces an enlarged shoulder 24 of stem 15 so as to keep the top stems in alinement with a limited relative abutment-terminated movement. Above valve seat 13 is a central outlet opening 25 preferably within a bushing 26 and closed by a check valve 27. Said check valve is seated by action of a spring 28 bearing against a central apertured bearing 29 having a temper screw 30 for controlling the pressure of the spring.

A lever 31 is pivoted at 32 and its free end is slotted and engaged by the shouldered neck 33 of a temper screw 34. Screw 34 has a terminal handle 35 and is threaded within a steam tight bushing 36 extending downwardly through cover 10 and having an upper stuffing box 37. A cross bar or arm 38 extends beyond pivot 32 across the top of the bucket 5 and is provided with depressing pins 39 adapted to be adjusted by manipulation of the screw 34 to engage downwardly against the bucket edge to fixedly hold the bucket in partly lowered position against return movement, when emptied. By this means, the valve 14 is relieved from sealing pressure against its seat for as long a period as may be desired for any purpose, as for blowing out the line, etc.

The construction and operation of the invention will be readily understood and appreciated from the foregoing description. Due to the shouldered slip joint between the upper section of the valve stem and the lower portion secured to the bucket, the fall of the bucket under its weight of water effects a jarring engagement between the shouldered abutments 20—22, thereby posi-

tively unseating the valve and overcoming any tendency to stick. The current of water or steam or water and steam, passing outwardly through the tangential ports 17 and across the vaned passages 18, will impart rotary movement to the valve and maintain it in clear contacting condition at all times.

The construction of the trap as a whole is very compact, comparatively simple and economical, and provides for continuous and economical operation. It may be changed or varied in design, or in different details of construction, but all such changes are to be understood as within the scope of the following claims.

What we claim is:

1. A steam trap having a vertically movable bucket and an outlet port having a surrounding depending shell provided with tangential openings therethrough, an outer surrounding circulation coping extending below the depending shell into the bucket, a rotatable valve within the depending shell adapted to open and close the outlet port provided with radial abutments registering with the tangential openings, and means

connecting the valve with the bucket providing a limited lost motion movement.

2. A steam trap having a vertically movable bucket and an outlet port having a surrounding depending shell provided with tangential openings therethrough, an outer surrounding circulation coping extending below the depending shell into the bucket, a rotatable valve within the depending shell adapted to open and close the outlet port provided with radial abutments registering with the tangential openings, a stem therefor, and a stem connected with the bucket having loose shouldered connection with the valve stem.

3. In a steam trap of the class described, a main casing, a vertically movable bucket therein, and a locking device for holding the bucket immovably within the casing consisting of a pivoted lever having a bucket engaging abutment and an adjusting screw therefor extending through to the exterior of the casing.

In testimony whereof we hereunto affix our signatures.

CHARLES E. VANCE.  
CHARLES S. McCLELLAND.