

# UNITED STATES PATENT OFFICE.

ELI K. WISELL, OF WARREN, OHIO.

## IMPROVEMENT IN LATHES FOR TURNING IRREGULAR FORMS.

Specification forming part of Letters Patent No. 127,286, dated May 28, 1872.

Specification describing a new and Improved Lathe for Turning Irregular Forms invented by ELI K. WISELL, of Warren, in the county of Trumbull and State of Ohio.

Figure 1 represents a side elevation of my improved lathe. Fig. 2 is a top view of the same. Fig. 3 is a vertical transverse section on a slightly enlarged scale, the line *c c*, Fig. 2, indicating the plane of section. Fig. 4 is a detail end view, partly in section, of the machine; and Fig. 5, a detail transverse section on the line *k k*, Fig. 2.

Similar letters of reference indicate corresponding parts.

This invention relates to certain improvements on the spoke-machine for which Letters Patent of the United States were granted to the present applicant on the 3d day of March, 1863, and 14th day of January, 1868. The object of the present invention is, first, to provide adjustable rests for the spokes or things under operation in such manner that the same are only supported behind the cutter-head in whichever direction they may be moved longitudinally. The invention consists in providing two vibrating supports—one on each side of cutter-head—and in connecting their ends with a pivoted beam, which is oscillated to raise the supports alternately, and thus insure the aforementioned object. Another object of the invention is to provide a balance for the vertically-adjustable horizontally-reciprocating pattern-frame, whereby the same will be held horizontally to keep the pattern and spokes or things under operation in the right position, and whereby it will also be eased off the pattern to prevent the rapid wear of the same and of the roller with which said pattern is in contact. This second object is attained by the arrangement of a horizontal rail, which supports the front of the pattern-frame, and is secured at the ends to levers that always keep it in a horizontal position, but are weighted to crowd the rail upward whenever there is an opportunity for so doing, by the elevation of the pattern-frame.

A in the drawing represents the stationary frame of the machine. B is the shaft carrying the cutter-head C, and hung in bearings transversely in the frame A. The shaft B receives continuous rotary motion by a system of belts, *a a*, or equivalent means, from a driving-shaft,

D, which is hung in the end of the frame A. E is the reciprocating frame, which carries the pattern F and the articles to be turned back and forth over the cutter-head. This frame E is, at the back of the machine, pivoted by ears *b b* to a stationary horizontal rod, *d*, on which it can swing whenever it is raised or lowered by the pattern. The latter rests on and moves over a roller, *e*, which has its bearings in ears that project from the frame A. Thus as the pattern moves over the roller *e* it will cause the frame E to be swung up when a thicker and down when a thinner part of it comes in contact with said roller, substantially as set forth in my aforesaid Letters Patent. In cross-pieces of the frame E are the bearings of the several arbors, *f f*, to which the things to be shaped—be the same tenons, handles, or others—are secured. The arbors *f f* at one end of the frame E are, by gearings *g*, connected with the journals of the pattern F, so as to turn simultaneously therewith, also as substantially set forth in the aforementioned Letters Patent. The requisite intermittent rotary motion is imparted to the pattern and the articles to be shaped by a pawl, *h*, which is pivoted to a bell-crank, *i*, that rides over inclines *j j* on the frame A at the end of the strokes of E, respectively. The pawl is thereby vibrated, and moves a ratchet-wheel, *l*, whose axle transmits the motion to the gearing. In front, the reciprocating-frame E rests on a rail, G, which is, by pivoted levers H H, connected with the front of the frame A. The frame E has rollers *m m*, that support it directly on the rail G, and ride thereon. One of the levers H has a weighted extension or arm, *n*. The other lever may also be thus provided. By the weight I on *n* the rail G is crowded upward against the frame E, and, whenever the latter is elevated by the action of the pattern, the rail G will follow—in fact assisting in the elevation. The levers H being of equal lengths, insure the constant horizontal position of the rail G, and also of the frame E that rests thereon. The twisting of the frame E, and the consequent improper position of the articles to be shaped is thereby entirely avoided. The weight I serves, also, by bearing against the under side of the frame E, to ease the pattern and reduce its weight and friction on the roller *e*, thereby preserving both pattern and roll-

E. S. YENTZER.

Tuck-Creaser for Sewing-Machines.

No. 127,287.

Patented May 28, 1872.

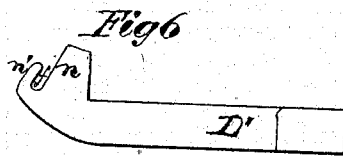
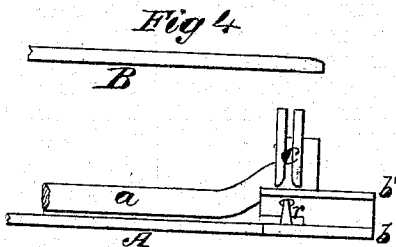
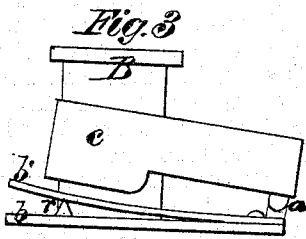
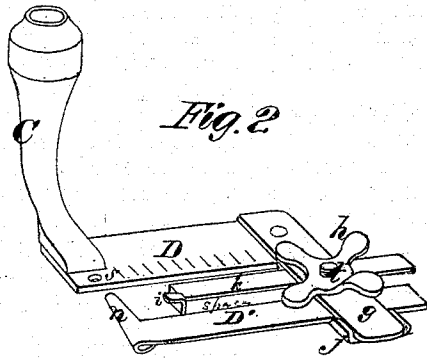
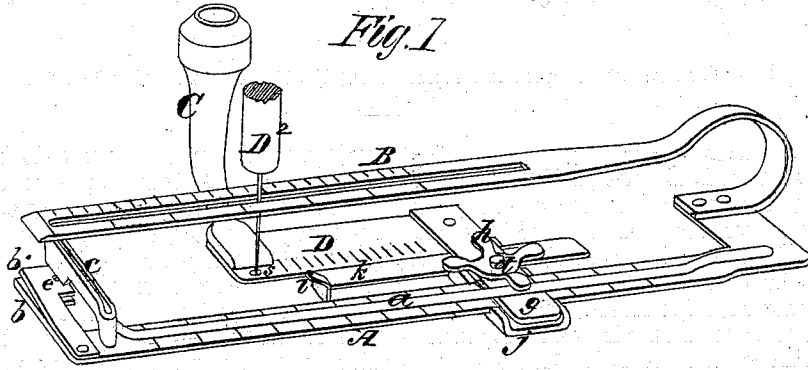

*Mitroesses.*  
R. J. Campbell  
J. W. Campbell

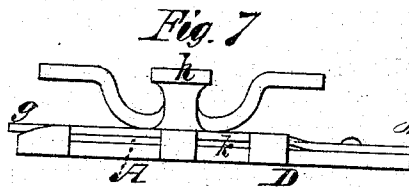

*Inventor*  
Erick S. Yentzer  
by his Attys  
Mason Kenwick & Lawrence

