

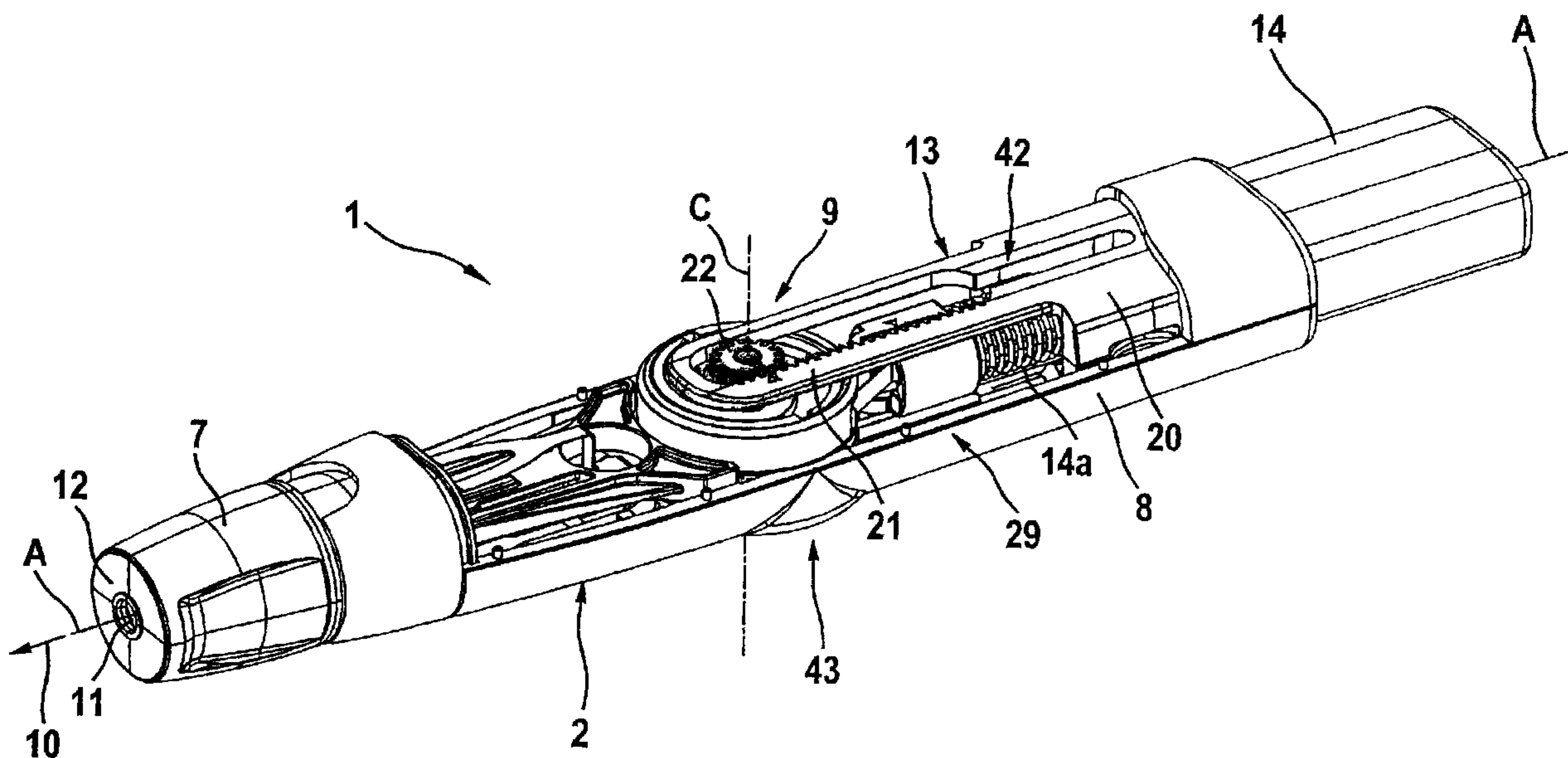

(22) Date de dépôt/Filing Date: 2004/07/26
 (41) Mise à la disp. pub./Open to Public Insp.: 2005/02/07
 (62) Demande originale/Original Application: 2 475 705
 (30) Priorité/Priority: 2003/08/07 (DE103 36 933.3)

(51) Cl.Int./Int.Cl. *A61B 5/151* (2006.01),
A61B 5/15 (2006.01)
 (71) Demandeur/Applicant:
F. HOFFMANN-LA ROCHE AG, CH
 (72) Inventeurs/Inventors:
THOES, BRUNO ROBERT, DE;
SCHABBACH, MICHAEL, DE;
KINTZIG, HANS, DE;
RUSCHKE, PETER, DE;
KUHR, HANS, DE
 (74) Agent: OGILVY RENAULT LLP/S.E.N.C.R.L.,S.R.L.

(54) Titre : SYSTEME DE PRELEVEMENT DE SANG
 (54) Title: BLOOD WITHDRAWAL SYSTEM



(57) **Abrégé/Abstract:**

Blood withdrawal system for withdrawing blood for diagnostic purposes, comprising a housing with a lancet, which can be moved within the housing, and a lancet drive with a drive spring and a cocking mechanism, wherein the cocking mechanism (13) includes an actuation element (14), which is coupled through an input-side coupling mechanism (29) to the drive spring (16) such that the drive spring (16) is tensioned during a cocking phase of the motion of the lancet drive (9) by moving the actuation element (14). The actuation element of the cocking mechanism is coupled to a track control mechanism comprising as components of the track control mechanism a control track part (45) and a control traveller (46), wherein the control traveller (46) performs a relative motion with respect to the control track part (45) during at least a part of the cocking phase, in which motion it travels along the control track (47) of the control track part (45), whereby at least a part of the motion of the lancet drive is controlled.

5

Abstract

Blood withdrawal system for withdrawing blood for diagnostic purposes, comprising a housing with a lancet, which can be moved within the housing, and a lancet drive with a drive spring and a cocking mechanism, wherein the cocking mechanism (13) includes an actuation element (14), which is coupled through an input-side coupling mechanism (29) to the drive spring (16) such that the drive spring (16) is tensioned during a cocking phase of the motion of the lancet drive (9) by moving the actuation element (14).

The actuation element of the cocking mechanism is coupled to a track control mechanism comprising as components of the track control mechanism a control track part (45) and a control traveller (46), wherein the control traveller (46) performs a relative motion with respect to the control track part (45) during at least a part of the cocking phase, in which motion it travels along the control track (47) of the control track part (45), whereby at least a part of the motion of the lancet drive is controlled.

30

5

Blood Withdrawal System

10

The invention refers to a blood withdrawal system for withdrawing blood for diagnostic purposes.

15 Lancets are used in analytical-diagnostic applications to withdraw a small amount of blood from a part of the body (usually the finger or the earlobe) by pricking the lancet into the body part to generate a wound. If done manually, specially trained personnel is required for
20 this purpose. However, puncturing is associated with considerable pain.

Blood withdrawal systems consisting of a puncturing device and corresponding lancets which are specifically
25 adapted to the corresponding device have been in use for a long time. A housing of the puncturing device contains a lancet drive by which a lancet is punctured mechanically through the skin. The driving element for the puncturing motion is a spring. Early in the
30 development very simple designs were common, in which the lancet was attached directly to one end of a compression spring which was arranged in an elongated housing (e.g. U.S. Patent No. 4,469,110).

However, blood withdrawal systems of this type failed to satisfy the difficult requirements that must be met when the regular monitoring of certain analytic blood values is required. This applies in particular to diabetics who should monitor their blood sugar level frequently in order to keep this level (which varies strongly depend on food ingestion, physical activity, etc.) always within certain limiting values by suitably adapting the insulin injections. Scientific investigations have shown that an intensive therapy involving at least four blood analyses per day can dramatically reduce the extremely severe late consequences of diabetes mellitus (for example, retinopathy which eventually leads to blinding of the patient).

15

This intensive therapy requires that the withdrawal of blood is associated with as little pain as possible. Numerous different blood withdrawal systems aiming for an improvement in this area have been developed.

20

The withdrawal of blood by means of a blood withdrawal system requires two basic functions:

- Firstly, the puncturing device must be brought to a state in which it is ready for puncturing by tensioning the drive spring. This is called the "cocking phase".
- Subsequently, the lancet drive is triggered and the relaxing motion of the drive spring drives the puncturing by the lancet. This is called the "drive phase".

30

In previous blood withdrawal systems, the puncturing phase was the kinematic reverse of the cocking phase. In other words: the drive was cocked simply by pushing the

lancet, after puncturing, back into its original position in which the spring was tensioned.

Better results, in particular with regard to the lowest possible pain level while keeping the handling simple, are achieved with blood withdrawal systems, whose lancet drive is designed in such a manner that the two functions are uncoupled from each other:

- 10 - In a cocking phase, the motion of an actuation element of a cocking mechanism is transmitted by an input-side coupling mechanism to the drive spring such that the spring is tensioned.
- 15 - In a drive phase, the relaxing motion of the drive spring is transmitted by an output-side coupling mechanism to the lancet such that the lancet performs the puncturing motion at high speed.

The two coupling mechanisms usually consist of, at least partially, different structural elements. In any case, the motions performed during the two phases differ from each other (rather than being the kinematic reverse of the other phase).

Blood withdrawal systems of this type are known, for example, from the following publications:

- (1) U.S. Pat. No. 4,442,836
- (2) U.S. Pat. No. 5,318,584
- (3) U.S. Pat. No. 6,409,740
- 30 (4) U.S. Pat. No. 6,419,661
- (5) EP 1 254 632 A1

Despite the extensive development efforts which resulted in the constructions described in these documents and numerous others, there is a strong interest to have a

blood withdrawal system which optimally satisfies simultaneously the difficult and to some extent contrary requirements (minimal pain sensation, simple handling, compact design as slim as possible, cost-efficient
5 fabrication).

To satisfy these requirements, a blood withdrawal system is proposed according to a first main aspect of the invention, which comprises a housing with an exit opening
10 for the tip of a lancet, which is mobile within the housing along a pre-determined puncturing path, and a lancet drive with a drive spring and a cocking mechanism, the cocking mechanism including an actuation element which is coupled to the drive spring via an input-side
15 coupling mechanism such that the drive spring is tensioned in a cocking phase of the motion of the lancet drive upon motion of the actuation element, and the drive spring is coupled to the lancet via an output-side coupling mechanism such that the lancet, during a drive
20 phase of the motion of the lancet drive, is moved at high speed along the pre-determined puncturing path in the puncturing direction driven by the relaxing motion of the drive spring until the tip of the lancet exits out of the exit opening to generate a wound. The system is
25 characterized in that the actuation element of the cocking mechanism is coupled to a track control mechanism comprising as components of the track control mechanism a control track part and a control traveller, wherein the control traveller performs a relative motion with respect
30 to the control track part during at least a part of the cocking phase, in which motion it travels along the control track of the control track part whereby at least a part of the motion of the lancet drive is controlled.

According to the invention an additional control track mechanism is provided in addition to the coupling mechanisms effecting the transmission of force from the actuation element to the drive spring (cocking phase) and from the drive spring to the lancet (drive phase). This additional control track mechanism is coupled to the actuation element of the cocking mechanism and controls at least a part of the motion of the lancet drive. It consists of two parts, which are designated components of the track control mechanism, namely a control track part and a control traveller. Its controlling or steering effect is based on an interaction of the control track part and the control traveller with the lancet drive during the motion of the lancet drive. This interaction includes a motion of the control traveller relative to the control track, in which the control traveller follows, i.e. travels along, the control track and thereby effects a lancet drive controlling or steering function during at least a part of the cocking phase and/or in the puncturing phase.

The required guidance of the control traveller along the control track can be achieved by different constructive measures. The control track can be formed by a groove in the control track part whose width is adapted to the dimensions of the control traveller such that the latter is guided precisely within the control track. The guiding effect can also be achieved by implementing the control track in the form of a slide surface against which the control traveller is pressed by spring action. In any case, one of the components is coupled to the actuation element of the cocking mechanism such that it is moved synchronously with the actuation element. The coupling can be rigid or movable. In the case of a movable coupling, common coupling elements, such as levers, can,

for example, be used to connect the actuation element of the cocking mechanism to the "input-side" component of the track control mechanism to which the actuation element is coupled. Preferably, this input-side component is the control track part, whereas the output-side component of the track control mechanism (which is coupled to the lancet drive such that it transmits the steering effect of the track control mechanism to the lancet drive) is preferably formed by the control traveller.

The relative motion of the control traveller with respect to the control track part can be realized by different combinations of motions of the two components of the track control mechanism. For example, in a section of the relative movement the control track part can be moved, while the control traveller is stationary with respect to the housing of the puncturing device. In other sections, the movement along the control track can be based on a motion of the control traveller while the control track part is stationary. Finally, both components of the track control mechanism can be moved simultaneously. Details depend on the individual case at hand. Preferably, the control track part is moved during at least a part of the desired control period in a translational motion, whereas the control traveller preferably moves at least partly on a circle.

The actuation element of the cocking mechanism is usually realized in the form of a cocking button which projects from the rear end (opposite from the puncturing opening) of an elongated housing and generally is actuated by pressing with the thumb. However, the invention is also suitable for use with other actuation elements of the cocking mechanism, e.g. a pusher which is movable along

the wall of the housing or an actuation element which can be moved by pulling and is formed, for example, by the rear part of the housing. Hereinafter, reference shall be made to a cocking button for exemplary purposes without
5 limiting the generality.

The track control mechanism which is separate from the mechanical elements required in the lancet drive for cocking (by transmission of force from the actuation
10 element to the lancet drive), but coupled to the cocking button of the lancet drive achieves several advantageous functions:

- Due to the fact that the track control mechanism is coupled to the cocking button of the lancet drive, but
15 is independent of the transmission of force, it becomes possible to assign additional functions (aside from the cocking of the lancet drive) to the cocking button, such as, for example, the triggering of the drive phase (puncturing motion) or the removal of a
20 used lancet from the puncturing device. This allows "one-hand operation".
- The track control mechanism can be used to establish defined intermediate positions of the cocking button, which characterize intermediate stages in the handling
25 of the blood lancet system, and thus clearly indicate to the user the status of the system (for example, "relaxed", "cocked").
- By providing a "reversing section" in the control track it is possible to realize an operation of the
30 cocking button of the "push-button switch type", as will be illustrated in more detail below.
- By means of one-way sections of the control track, which are also described in more detail below, it is possible to ensure that the journey of the traveller

along the control track is possible in only one direction and consequently to achieve a certain sequence of steps without undesired repetition. An important example is a "re-cocking lock" preventing repeated cocking of the drive.

According to a second main aspect, which preferably is used in combination with the first main aspect but is also advantageously independent thereof, the invention refers to a blood withdrawal system with the general features explained above, which includes a lancet ejection mechanism with a release element which is borne in the housing such that it can be switched between a passive position and an active position, the lancet ejection mechanism being activated when the release element is in its active position such that actuating an actuation button of the lancet ejection mechanism removes a used lancet from the housing, and the lancet ejection mechanism being inactivated when the release element is in its passive position such that actuating the actuation button does not lead to the ejection of a lancet, the front end, in the puncturing direction, of the housing with the puncturing opening is formed by a cap, which can be removed in order to remove used lancets, the cap, when attached, interacts with the release element such that it is in its passive position, and the release element is switched to its active position upon removal of the cap.

The term "ejection mechanism" is generally used to designate a combination of mechanical elements which together allow removal of the lancet from the puncturing device by moving an actuation button without having to touch the lancet. In this context, "ejection" does not mean that the lancet is accelerated during its removal from the device. Rather, it is usually considered to be

advantageous if the ejection mechanism only opens a lancet holder of the puncturing device such that the lancet falls out by the effect of gravity.

5 By the design of the second main aspect of the invention the ejection mechanism is non-functional as long as the cap is attached to the front end of the housing of the puncturing unit. The mechanism is activated only upon
10 removal of the cap whereby possible mishandling is prevented. Furthermore it is possible to use the cocking button simultaneously as actuation button of the ejection mechanism without adversely affecting its other
15 functions, for example by restricting its possible path of motion. This is also explained in more detail below.

It is preferable to use both features of the invention in lancet systems whose lancet drive includes a drive rotor which is driven by the drive spring and rotates about an axis, wherein the drive rotor, driven by the drive spring
20 in the drive phase of the lancet drive, performs a rotational motion which is transformed into the puncturing motion by the output-side coupling mechanism. A rotor drive of this type is used, for example, in documents (2), (3) and (4) cited above.

25 It is particularly preferable to use the present invention in combination with a special rotor drive as described in EP 1384438 A1 (and its equivalents: U.S. 7,223,276 and JP 3,746,772) which was published after
30 the priority date of this patent application.

In the rotor drive described therein, the end of the drive spring which is remote from the drive rotor is

supported by a rotatable tensioning element, which can be rotated in the same direction, in which the drive rotor rotates during the drive phase, in order to tension the drive spring while the rotation of the drive rotor is inhibited. The tensioning element is locked against a reverse motion during the drive phase such that the drive rotor performs a rotational motion after the inhibition is released, which rotational motion is transformed into the puncturing motion by the drive-side coupling mechanism. In such a drive the mentioned elements are rotated in the same direction in an alternating manner during the cocking phase and during the drive phase. This principle is designated "One Way Alternating Drive and Cocking", or OWADAC for short.

15 In accordance with another aspect of the present invention, there is provided a blood withdrawal system for withdrawing blood for diagnostic purposes, the system comprising: a housing, wherein a lancet can be moved within the housing along a pre-determined puncturing path to perform a puncturing motion; and a lancet drive with a drive spring and a cocking mechanism; wherein the cocking mechanism includes an actuation element, wherein the actuation element is coupled by an input-side coupling mechanism to the drive spring, said input-side coupling mechanism effecting a transmission of force from the actuation element to the drive spring, such that the drive spring is tensioned when the actuation element is moved during a cocking phase of the lancet drive; wherein the drive spring is coupled by an output-side coupling mechanism to the lancet, said output-side coupling mechanism effecting a transmission of force from the drive spring to the lancet, such that the lancet during a drive phase of the lancet drive, is driven by the

relaxing motion of the drive spring at a high speed along the pre-determined puncturing path to perform the puncturing motion to generate a wound; and wherein the actuation element is coupled to a track control mechanism, said track control mechanism being additional to the input-side coupling mechanism effecting the transmission of force from the actuation element to the drive spring and additional to the output-side coupling mechanism effecting the transmission of force from the drive spring to the lancet, the track control mechanism comprising a control track part and a control traveler, wherein the control traveler performs a relative motion with respect to the control track part during at least a part of the cocking phase, in which the control traveler travels along a control track of the control track part, wherein at least a part of the motion of the lancet drive is controlled.

In accordance yet with another aspect of the present invention, there is also provided a blood withdrawal system for withdrawing blood for diagnostic purposes the system comprising: a housing, wherein a lancet can be moved within the housing along a predetermined puncturing path to perform a puncturing motion; a lancet drive with a drive spring and a cocking mechanism; wherein the cocking mechanism includes an actuation element, which is coupled by an input-side coupling mechanism to the drive spring such that the drive spring is tensioned when the actuation element is moved during a cocking phase of the motion of the lancet drive; wherein the drive spring is coupled by an output-side coupling mechanism to the lancet such that the lancet is, during a drive phase of the motion of the lancet drive driven by a relaxing motion of the drive spring, moved at high speed along the predetermined puncturing path to

generate a wound; and a lancet ejection mechanism, wherein the lancet ejection mechanism, includes a release element which is borne in the housing such that it can be switched between a passive position and an active position, wherein
5 when the release element is in its active position such that actuating an actuation button of the lancet ejection mechanism removes a used lancet from the housing; wherein the front end of the housing is formed by a cap, which can be removed in order to remove used lancets, such that when
10 the cap is attached, the cap interacts with the release element such that it is in its passive position, and wherein the release element is switched to its active position upon removal of the cap.

In accordance with yet another aspect of the present
15 invention, there is also provided a blood withdrawal system for withdrawing blood for diagnostic purposes, the system comprising: a housing wherein a lancet can be moved along a pre-determined puncturing path to perform a puncturing motion; a lancet drive comprising a drive spring and a
20 cocking mechanism, wherein the cocking mechanism includes an actuation element which is coupled by an input-side coupling mechanism to the drive spring, said input-side coupling mechanism being adapted to effect a transmission of force from the actuation element to the drive spring, such that
25 the drive spring is tensioned when the actuation element is moved during a cocking phase of the motion of the lancet drive, and the drive spring is adapted to be coupled by an output-side coupling mechanism to a lancet such that said output-side coupling mechanism is adapted to effect a
30 transmission of force from the drive spring to a lancet, such that the lancet can be driven by the relaxing motion of the drive spring and moved along a pre-determined puncturing

path to perform a puncturing motion to generate a wound; and a lancet ejection mechanism for removing a used lancet from the housing, wherein the actuation element of the cocking mechanism of the lancet drive serves also as an actuation
5 button for the lancet ejection mechanism, thereby performing the functions of tensioning the drive spring during the cocking phase and actuating the lancet ejection mechanism.

The invention is illustrated in more detail hereafter on the basis of exemplary embodiments shown in the figures. The
10 illustrated and described features can be used individually or in combination to create further preferred embodiments of the invention. In the figures:

Fig. 1 shows a partially cut-open perspective view of a blood withdrawal system according to the invention;

15 Fig. 2 shows a perspective view of a drive module of the lancet drive used in the blood withdrawal system according to Fig. 1;

Fig. 3 shows an exploded perspective view of components of the module of Fig. 2;

20 Fig. 4 shows a perspective view of a module according to Fig. 2 in a partially assembled state;

Fig. 5 shows a perspective view of a lancet holder of the blood withdrawal system according to Fig. 1;

- Fig. 6 shows a perspective view of a subunit of the blood withdrawal system according to Fig. 1 consisting of a drive module according to Fig. 2 and a lancet holder according to Fig. 5;
- 5 Fig. 7 shows a perspective view of a part of the blood withdrawal system shown in Fig. 1 as seen from the other side ("control side");
- Fig. 8 shows an exploded view of a control track part and a drive rotor with control traveller;
- 10 Fig. 9 shows a side view onto parts of an ejection mechanism with a release element in its passive position;
- Fig. 10 shows a side view onto parts of an ejection mechanism with a release element in its active position;
- 15

The blood withdrawal system 1 shown in the figures consists of a puncturing device 2 and lancets 3. The mounting and the guide means for a lancet 3 in puncturing device 2 are shown in Figure 7. Holding latches 4a of a lancet holder 4 encompass the rear part of the lancet called lancet body 5. A lancet tip 6 projects forward from lancet body 5.

20

25 During the puncturing process, the lancet holder 4 is guided by means of a housing part (not shown) serving as guide means. Thereby indirectly the required guidance of the lancet on a pre-determined puncturing path (here along the main axis A of puncturing device 2) is provided. Thus, the lancet is indirectly guided via the lancet holder 4.

30

However, the invention can also be used with puncturing devices, in which the lancet is "directly guided", i.e.

resides directly in a part of the housing providing the required guidance during the puncturing motion (a cartridge containing a plurality of lancets, for example). More details can be taken from EP 1384438 A1.

5

The housing 8 of puncturing device 2 contains a lancet drive 9 whose function is to move a lancet with high speed in the puncturing direction (arrow 10) until its tip exits from an exit opening 11, while a contact surface 12 of puncturing device 2, which surrounds exit opening 11, is pressed against a body part not shown herein. This generates a wound in the body part for the withdrawal of blood. The housing 8 of the puncturing device has an elongated shape. The end with exit opening 11 is designated herein as front end, and the opposite end is designated rear end. The front end of housing 8 is formed by a removable cap 7.

Figures 1 to 6 illustrate the design features of the lancet drive 12, which are required for the transmission of force during the cocking phase and during the drive phase. During the cocking phase, in order to tension the spring, the force exerted onto a cocking button 14 is transmitted by a cocking mechanism (designated in its entirety as 13) to a drive spring 16 (which in the case shown is integrated into a drive module 15). During the drive phase, the drive spring 16 relaxes and thereby drives a drive rotor 17 whose rotational motion is, in turn, transformed into the translational puncturing motion of lancet holder 4. This transmission of force in the present invention is identical to that in EP 1384438 A1.

The components of drive module 15 include drive rotor 17 and a tensioning element 19, both being rotatable about a

35

common axis C which extends perpendicular to the puncturing direction 10 and to the longitudinal axis A of the puncturing device 2.

5 In order to cock the lancet drive 9, the cocking button 14, which is movable in a translational motion, is pushed together with a force transmission part 20 in puncturing direction 10. One component of the force transmission part 20 is a toothed rack 21 driving a pinion gear 22
10 which is coaxial to the tensioning element 19. The pinion gear 22 is connected to the tensioning element 19 by means of a free-wheel device 23 such that the two parts are coupled to each other during the cocking motion (motion of the force transmission part 20 in the
15 puncturing direction), but uncoupled from each other during the return of the force transmission part 20, and cocking button 14, under the effect of a restoring spring 14a. In the embodiment shown, the free-wheel device 23 is realized by means of two elastic latches 24, which are
20 connected to the pinion gear 22. The latches 24 are located in a recess 25 of the tensioning element 19, which recess 25 faces away from the drive rotor 17 and has two limit stops 27, at which the ends of the latches 24 abut in the coupling rotation direction (clockwise in
25 Figure 2), whereas the pinion gear 22 can rotate freely relative to the tensioning element 19 in the reverse direction.

The rotation of the tensioning element 19 tensions the
30 drive spring 16, which is a helical spring borne in a recess 28 of the tensioning element 19 which recess faces towards the drive rotor 17. The force transmission part 20 with toothed rack 21, the pinion gear 22, the free-wheel device 23 and the actuation element 10 jointly form
35 an input-side coupling mechanism 29, which transmits the

force exerted onto the cocking button 14 to the drive spring 16 during the cocking phase.

The output-side coupling mechanism 30, which transmits
5 the force of the spring 16 to the lancet 3 during the drive phase, includes a control curve 31 which is formed by a circumferential groove 32. In the example shown, the control curve 31 takes the shape of an circle which is eccentric with respect to axis C. A control pin 33, which
10 is a component of the lancet holder 4, travels along the control curve 31 during the rotation of drive rotor 17. To fix a lancet, the lancet holder 4 is provided with elastic arms 35 and a limit stop element 36, whose shapes are adapted to the corresponding shape of the lancet body
15 5 such that lancet 3 is held in an exactly reproducible longitudinal position within lancet holder 4.

The rear end of lancet holder 4 with control pin 33 extends through a circumferential slit of the drive
20 module 15 in such a manner that there is no interference with the rotational motion of the components of module 15. In the embodiment shown this is achieved by means of a separating disc 37 made from metal, which is placed on a plateau 38 of drive rotor 17 in such a manner that a
25 circumferential gap with a sufficient width to accommodate lancet holder 4 remains between the disc and the parts of the rotor 17 which are radially outwards from control curve 31. In the embodiment of the lancet drive 9 shown, the motion phases of the drive follow the
30 OWADAC principle as follows:

- During the cocking phase, the rotatable tensioning element 19, driven by cocking button 14 via force transmission part 20 by means of toothed rack 21 and pinion gear 22, rotates in a predetermined direction
35 (clockwise in Figures 1 and 2), whereby the drive

spring 16 is tensioned, while the rotation of drive rotor 17 is inhibited (by means of the trigger mechanism described in more detail below).

- 5 - In the drive phase, the drive spring 16 drives the drive rotor 17 (after release of the inhibition), while simultaneously the tensioning element 19 is locked against a reverse rotation (for example by an elastic catch, not shown herein, engaging a recess of tensioning element 19).

10

Figures 7 to 9 show the essential design elements of the track control mechanism 40 and the ejection mechanism 41, which are located, relative to drive rotor 17, on the side of puncturing device 2, which is opposite from the drive side 42 shown in Figure 1 and is called control side 43.

The components of the track control mechanism 40 include a control track part 45 and a control traveller 46, which, in the embodiment shown, is a pin fixed to drive rotor 17. Because the control traveller is fixed to the drive rotor 17, it can move only on a circular path about axis C thereof. Drive spring 16 exerts a torque (which varies in magnitude depending on its tensioning state, but always acts in the same direction) onto drive rotor 17 and thereby on control traveller 46 (in clockwise direction in the Figures).

In the assembled state, drive rotor 17 is located adjacent to the control track part 45 in such a manner that the control traveller 46 is positioned within a control track 47 of control track part 45 (this position of the control traveller 46 is indicated by broken lines in Figure 8). A relative movement of control traveller 46 with respect to the control track part 45 results, on the

one hand, when the control track part 45 is moved parallel to the longitudinal axis A of the puncturing device 2 and, on the other hand, by means of the motion of the control traveller 46 on a circular path about axis C. The translational motion of control track part 45 results from the coupling thereof with cocking button 14. In the preferred embodiment shown, the control track part 45 and the force transmission part 20 with toothed rack 21 are manufactured as one part and are formed approximately U-shaped such that in the assembled position the two legs of the U extend on the two sides of drive module 15, i.e. force transmission part 20 on drive side 42 and control track part 45 on guide side 43. The rear end of components 20, 45, which are connected to each other, is attached to cocking button 14 such that both parts are moved equally in a translational motion by actuation of cocking button 14.

Due to the actuation of cocking button 14 and the biasing action of the drive spring (resulting in a rotational motion of the drive rotor 17), the control traveller 46 travels along a control path 47, shown as dash-dot lines in Figure 8, as defined by control profiles 49, 50, 51 embossed into control track part 45. The most important functional positions of the control track are identified in Figure 8 by means of letters to which reference is made in the following explanation:

- a) This is the initial position of the traveller 46 when the lancet drive is not loaded and the cocking button projects the farthest from housing 8. In this state the axis C of the drive rotor 17 is in position a1.
- b) Here the control traveller 46 is positioned in a pocket 52 of the guide profile 50, which is shaped

such that the control traveller 46 can be driven out only in one direction (continuing the previous motion). The section of control track 47 defined by pocket 52 is called one-way section 53, since the control traveller, once driven into the one-way section 53, can be driven out only in one direction. Thus, the control traveller 46 is capable of a relative motion with respect to the control track part 45 only in one direction of control track 47 beyond one-way section 53. This arrangement provides a safety function since multiple cocking of the lancet drive, which may lead to damage, is prevented.

- c) When the cocking button 14 is depressed further (resulting in a forward motion of control track part 45), the control traveller 46 is driven by the action of the drive spring to this position in front of a locking wall formed by the guide profile 51, which prevents further depression of the cocking button.
- d) When cocking button 14 is released, resulting in a rearward motion of control track part 45, the control traveller reaches this position, which corresponds to a stable intermediate position and in which the lancet drive is ready to be triggered, i.e. for starting the drive phase. Here, the cocking button is in a position which clearly differs from its initial position (corresponding to control track position a) and can additionally be labeled (e.g. by a color mark on the shaft of the cocking button 14). Thereby it is unambiguously indicated to the user that the device is in its cocked state and ready for use.

The section of the control track between the positions c and e forms a reversing section 54.

Because of the U-shape of this section, the control traveller 46 can be driven out of reversing section 54 only after performing a relative motion with respect to control track part 45 in the reverse direction of the previous motion. This provides for actuation of the cocking button with a stable intermediate position as with a push-button switch.

- 5
- 10
- 15
- 20
- 25
- 30
- e) By depressing the cocking button 14 again, the control traveller 46 reaches this position, in which the contact between control traveller 46 and control track part 45 is interrupted. The control traveller is free allowing the drive rotor 17 to perform a rapid rotational motion about rotor axis C, which at this point of time is in position e1. The cocking button 14 therefore performs two functions, namely cocking and triggering.
 - f) The rotational motion is terminated when the control traveller 46 again contacts control track part 45 (i.e., in the case shown, its guide profile 49) in this position.
 - g) Under the action of the restoring spring 14a, the cocking button 14 and, jointly with the button, the control track part 45 are moved backwards again, whereby the control traveller reaches its initial position via this position. Position g again marks a one-way section 55, in which the control traveller is positioned in a pocket 56, which prevents a motion against the predetermined direction of control track 47.

Figures 8 to 10 show the essential parts of the ejection mechanism, which in its entirety is designated 41 and

consists, in the embodiment shown, of cocking button 14, control track part 45 and a release element 61. These elements are each borne in such a manner that they can be displaced in a translational motion in the puncturing direction 10 (and therefore in the direction of axis A of the device). They form a force transmission chain, which is symbolically indicated by arrow 70 and by which the motion of an actuation button of the lancet ejection mechanism is transmitted to the lancet holder 4 in such a manner that the lancet 3 is released and can fall out of the holder 4 by the action of gravity. In the embodiment shown, the actuation button of the lancet ejection mechanism simultaneously is the actuation element of the cocking mechanism, i.e. the cocking button 14. Though this is not absolutely required, it is particularly preferred. In this embodiment a single actuation button performs three functions (cocking, triggering, ejecting).

The release of the lancet in the embodiment shown is achieved by pushing sliding latches 62, which are provided on the release element 61, between the elastic latches 4a of the lancet holder 4 and a counter-bearing 63 of the lancet holder 4 which extends oblique-outwards. This causes the holding latches 4a to be pressed apart and release the lancet 3.

As long as the removable cap 7, which forms the front end of housing 8, is attached, the lancet ejection mechanism 41 is inactivated, i.e. actuation of the cocking button 14 does not result in ejection of the lancet. Removal of the cap switches the lancet ejection mechanism 41 to its active state.

The switching between the active and the passive state is achieved by means of a change in the position of the

release element as shown in Figures 9 and 10. In Figure 9, the release element is in its passive position, in which the force transmission chain 70 between the cocking button and the lancet is interrupted: cap 7 includes a counter-bearing 64, shown by dashed lines in Figure 9, which, as long as the cap is attached, pushes against the front end of an actuation part 65 on the release element 61. This causes a pressure part 68 of the release element to be pressed against an oblique surface 69 which is fixed relative to the device and shown only schematically in Figure 9. The release element is held in the horizontal position shown in Figure 9. If the front end of control track part 45 is displaced, as indicated by arrow 66, this motion is not transmitted to the release element 61, since the two parts are not mutually engaged.

In contrast, when the cap 7 is removed, the pressure exerted by the counter-bearing 64 on the actuation part 65 ceases and the release element 61 is moved under the action of a leaf spring 67 to the position shown in Figure 10. In this position, the rear end of release element 61 is within the movement path of control track part 45, such that a forward motion of the control track part 45 (upon actuation of the cocking button 14) is transmitted to the release element 61 and thereby also to the lancet.

CLAIMS:

1. A blood withdrawal system for withdrawing blood for diagnostic purposes, the system comprising:

a housing wherein a lancet can be moved along a pre-determined puncturing path to perform a puncturing motion;

a lancet drive comprising a drive spring and a cocking mechanism, wherein the cocking mechanism includes an actuation element which is coupled by an input-side coupling mechanism to the drive spring, said input-side coupling mechanism being adapted to effect a transmission of force from the actuation element to the drive spring, such that the drive spring is tensioned when the actuation element is moved during a cocking phase of the motion of the lancet drive, and the drive spring is adapted to be coupled by an output-side coupling mechanism to a lancet such that said output-side coupling mechanism is adapted to effect a transmission of force from the drive spring to a lancet, such that the lancet can be driven by the relaxing motion of the drive spring and moved along a pre-determined puncturing path to perform a puncturing motion to generate a wound; and

a lancet ejection mechanism for removing a used lancet from the housing, wherein the actuation element of the cocking mechanism of the lancet drive serves also as an actuation button for the lancet ejection mechanism, thereby performing the functions of tensioning the drive spring during the cocking phase and actuating the lancet ejection mechanism.

2. The system of claim 1 wherein the actuation element also is adapted to trigger the puncturing motion, such that the actuation element thereby performs the functions of tensioning the drive spring during the cocking phase, actuating the lancet ejection mechanism, and triggering the puncturing motion.

3. The system of claim 1 wherein the lancet ejection mechanism has an active position such that actuating the actuation button for the lancet ejection mechanism removes a used lancet from the housing and a passive position such that actuating the actuation button does not lead to the ejection of a used lancet from the housing.

4. The system of claim 3 wherein the lancet ejection mechanism includes a force transmission chain between the actuation button and the lancet, said force transmission chain being required for effecting an ejection of a lancet from the housing, wherein said force transmission chain is interrupted in the passive position of the lancet ejection mechanism.

5. The system of claim 4 wherein the force transmission chain further comprises a release element that can be switched between an active position and a passive position, corresponding to the active and passive positions, respectively, of the lancet ejection mechanism.

6. The system of claim 5 wherein the housing further comprises a front end, and a puncturing opening is formed by a cap which can be removed in order to remove used lancets, wherein the cap when attached to the front end

of the housing interacts with the release element to maintain the release element in its passive position, and wherein the release element is switched to its active position upon removal of the cap.

7. The system of claim 2 wherein the lancet ejection mechanism has an active position such that actuating the actuation button for the lancet ejection mechanism removes a used lancet from the housing and a passive position such that actuating the actuation button does not lead to the ejection of a used lancet from the housing.

8. The system of claim 7 wherein the lancet ejection mechanism includes a force transmission chain between the actuation button and a lancet, said force transmission chain being required for effecting an ejection of a lancet from the housing, wherein said force transmission chain is interrupted in the passive position of the lancet ejection mechanism.

9. The system of claim 8 wherein the force transmission chain further comprises a release element that can be switched between an active position and a passive position, corresponding to the active and passive positions, respectively, of the lancet ejection mechanism.

10. The system of claim 9 wherein the housing further comprises a front end, and a puncturing opening is formed by a cap which can be removed in order to remove used lancets, wherein the cap when attached to the front end of the housing interacts with the release element to maintain the release element in its passive position, and

wherein the release element is switched to its active position upon removal of the cap.

11. A blood withdrawal system for withdrawing blood for diagnostic purposes the system comprising:

a housing, wherein a lancet can be moved within the housing along a predetermined puncturing path to perform a puncturing motion;

a lancet drive with a drive spring and a cocking mechanism;

wherein the cocking mechanism includes an actuation element, which is coupled by an input-side coupling mechanism to the drive spring such that the drive spring is tensioned when the actuation element is moved during a cocking phase of the motion of the lancer drive;

wherein the drive spring is coupled by an output-side coupling mechanism to the lancet such that the lancet is, during a drive phase of the motion of the lancet drive driven by a relaxing motion of the drive spring, moved at high speed along the predetermined puncturing path to generate a wound; and

a lancet ejection mechanism, wherein the lancet ejection mechanism, includes a release element which is borne in the housing such that it can be switched between a passive position and an active position, wherein when the release element is in its active position such that actuating an actuation button of the lancet ejection mechanism removes a used lancet from the housing;

wherein the front end of the housing is formed by a cap, which can be removed in order to remove used lancets, such that when the cap is attached, the cap

interacts with the release element such that it is in its passive position, and wherein the release element is switched to its active position upon removal of the cap.

12. The system according to claim 11, wherein the release element is a part of a force transmission chain between the actuation button and a lancet, which three transmission chain is required for the ejection of the lancet.

13. The system according to claim 12, wherein the release element can be displaced in the same direction as the actuation button.

14. The system according to claim 12, wherein the three transmission chain is interrupted when the release element is in its passive position.

15. The system according to claim 11, wherein the actuation element of the cocking mechanism of the lancet drive is also the actuation button of the lancet ejection mechanism.

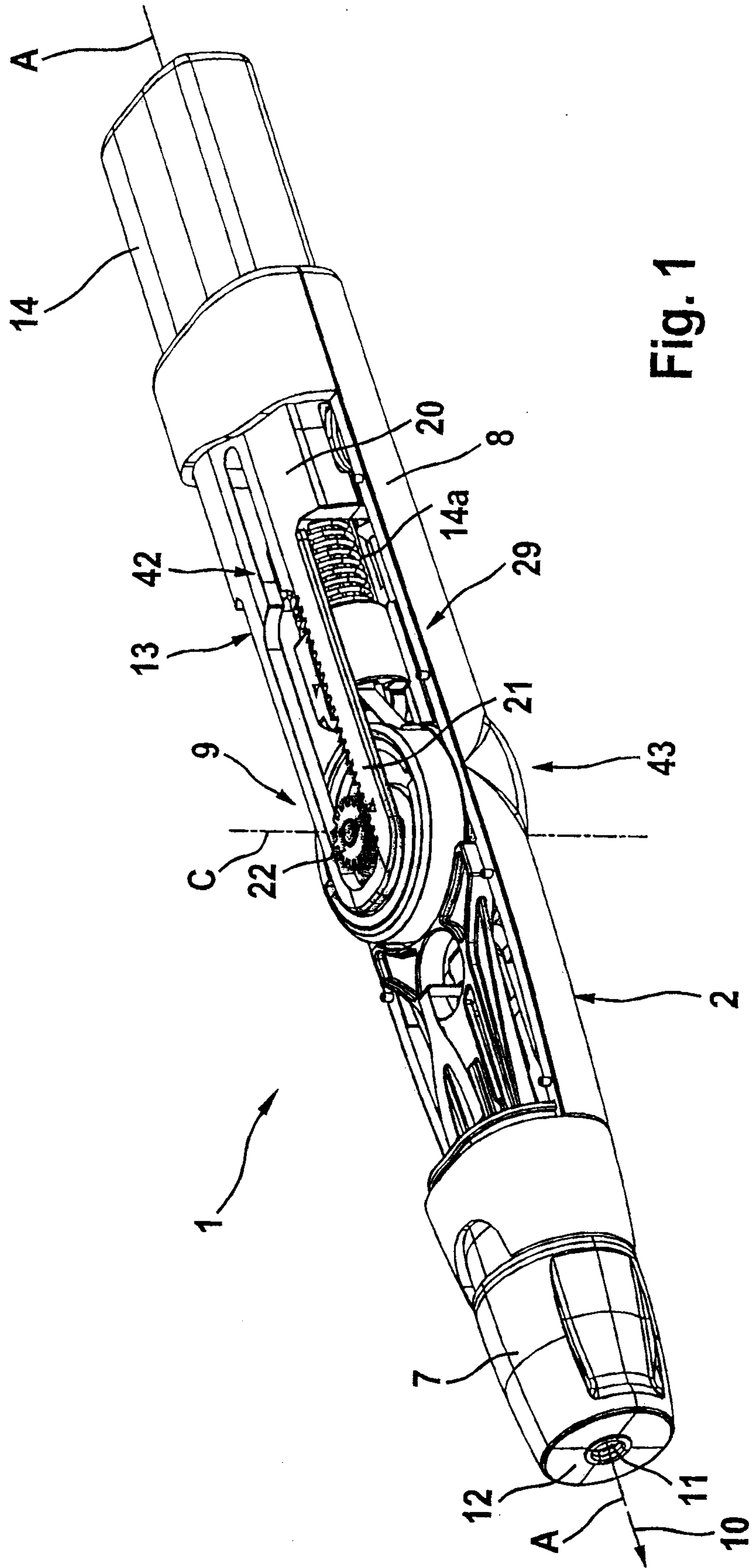

Fig. 1

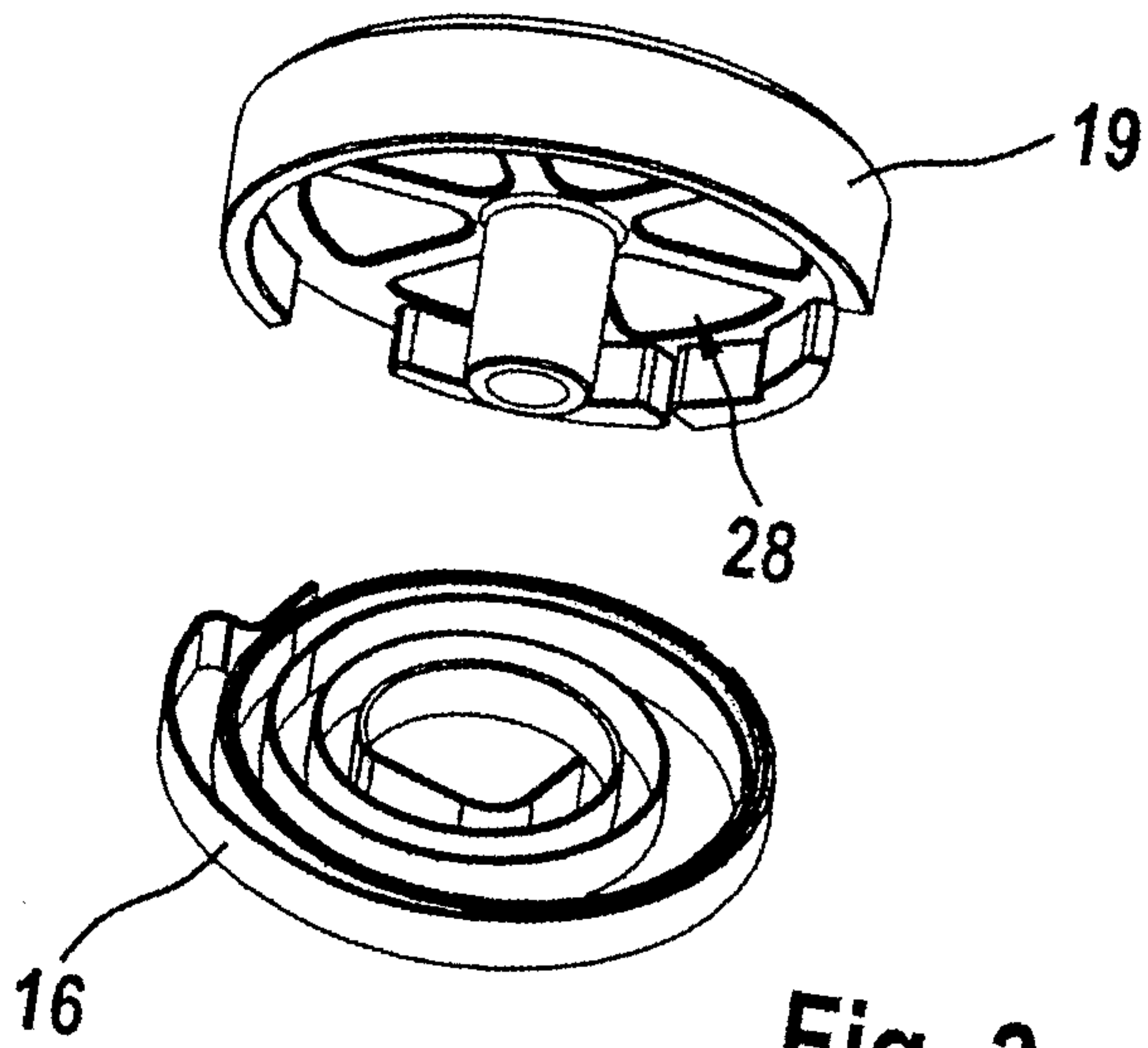

Fig. 2

Fig. 3

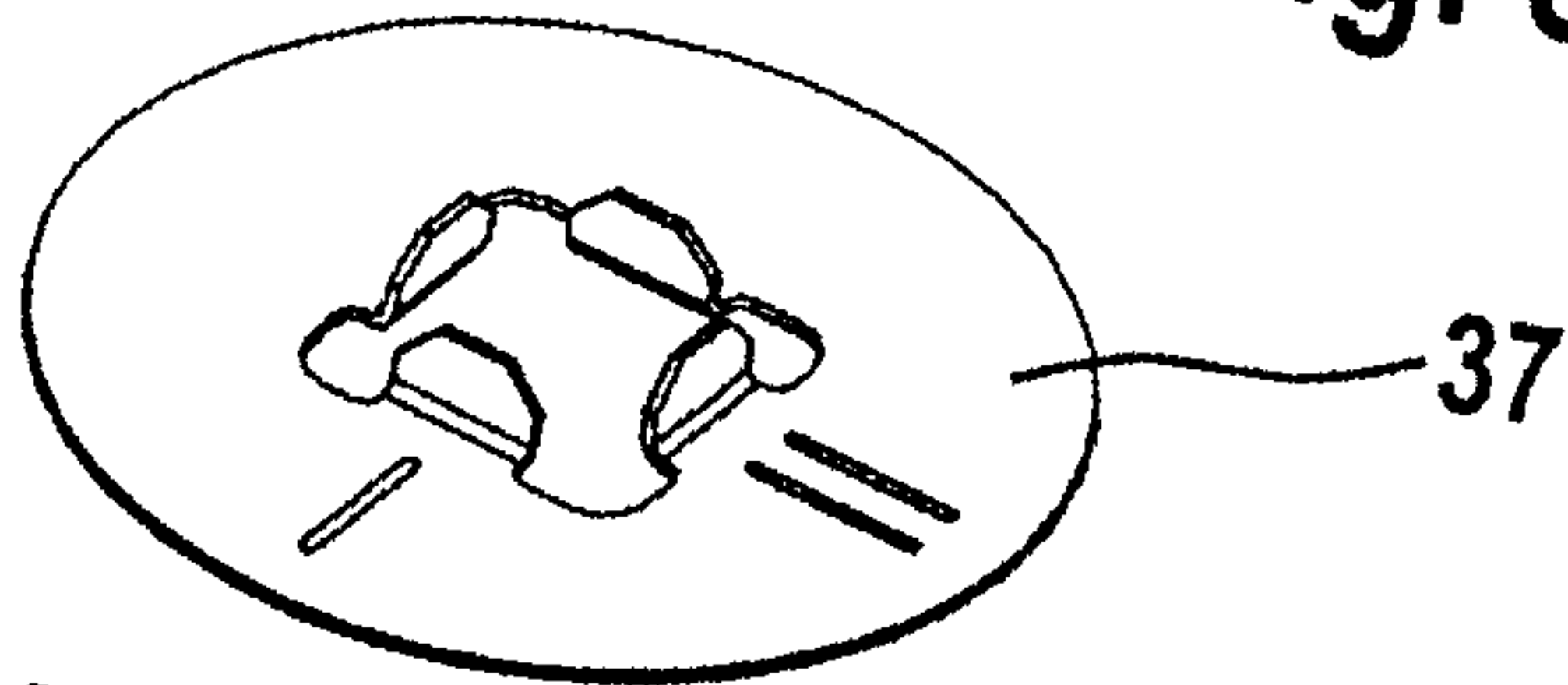

Fig. 4

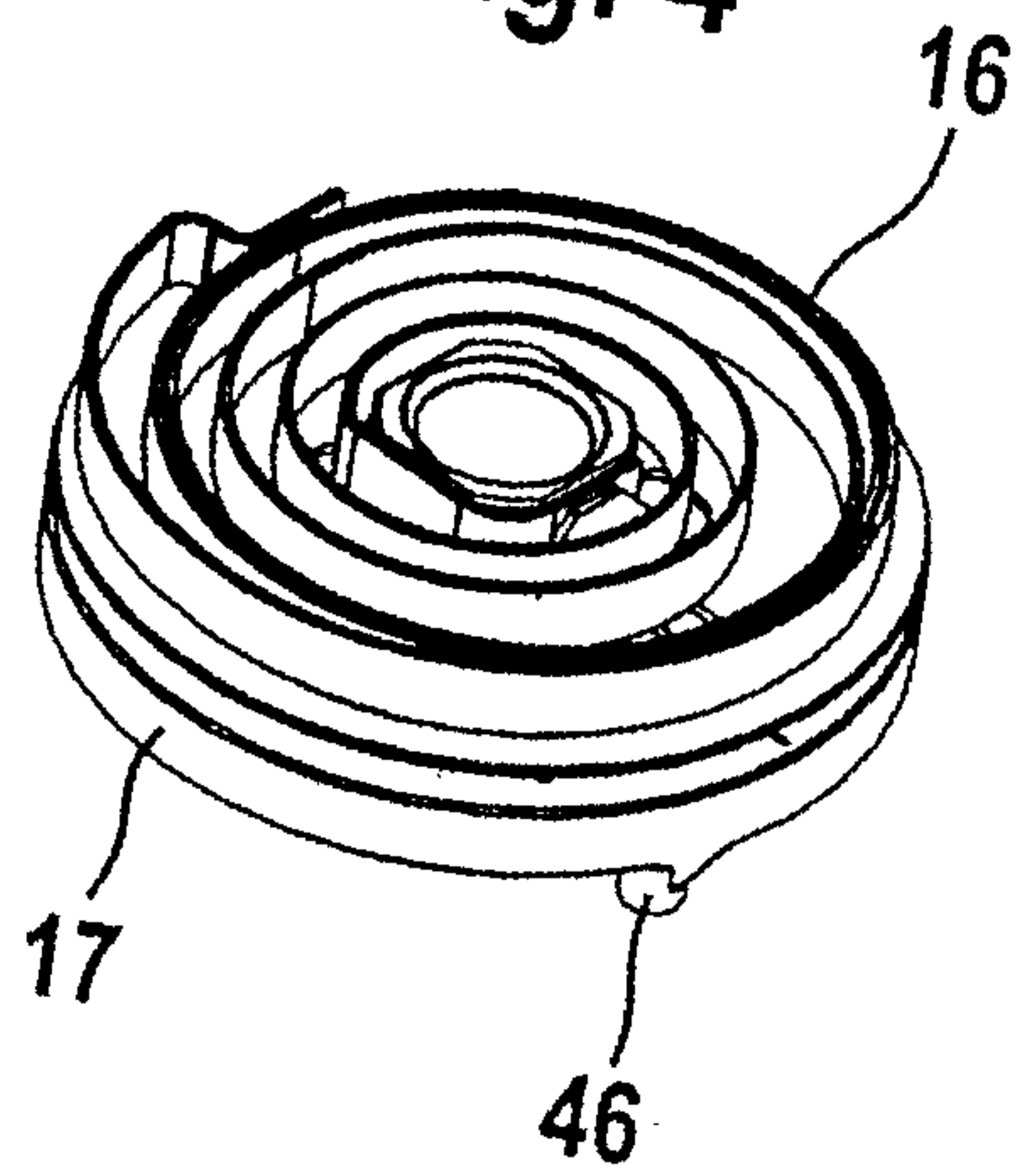
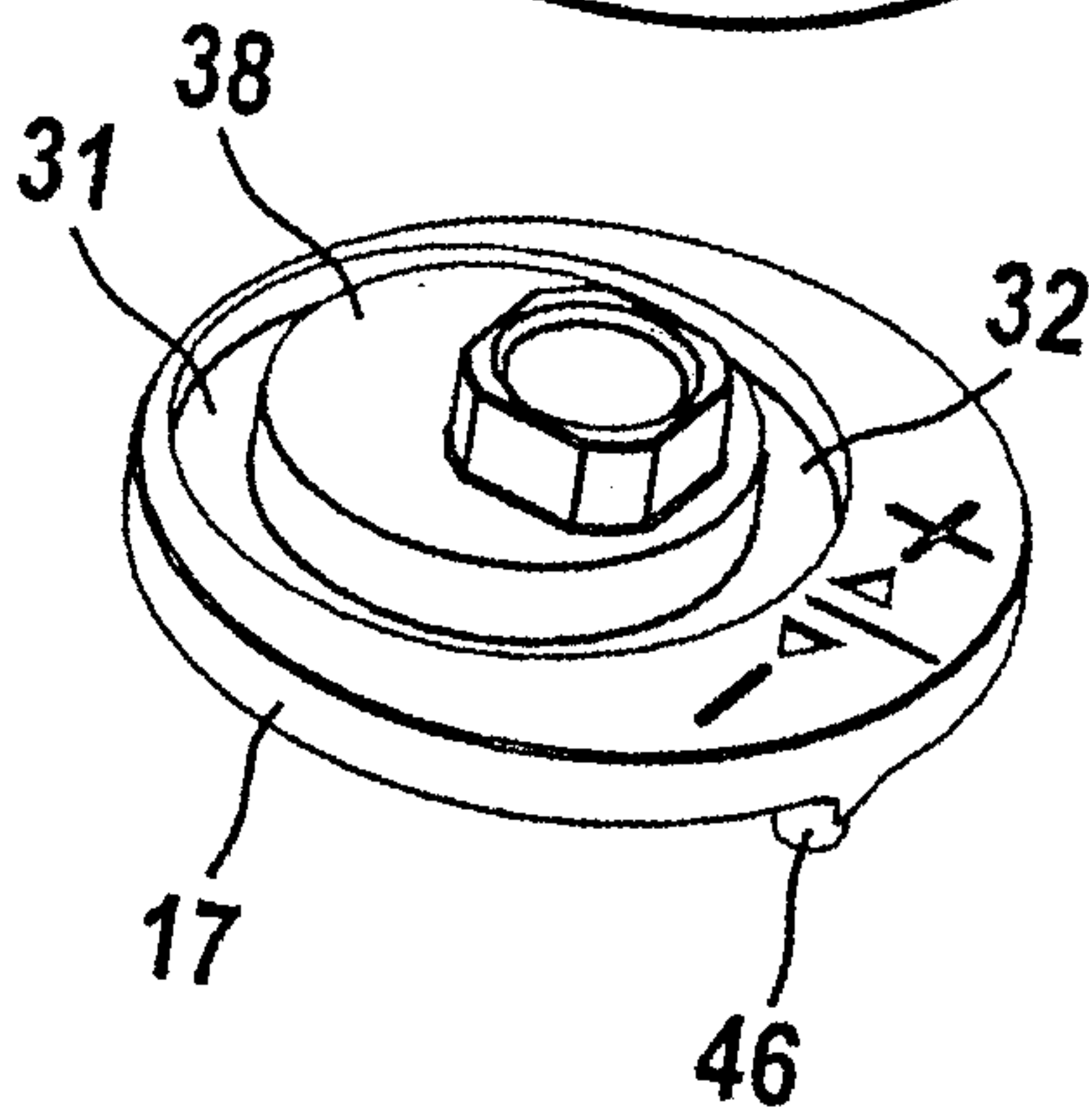

Fig. 5

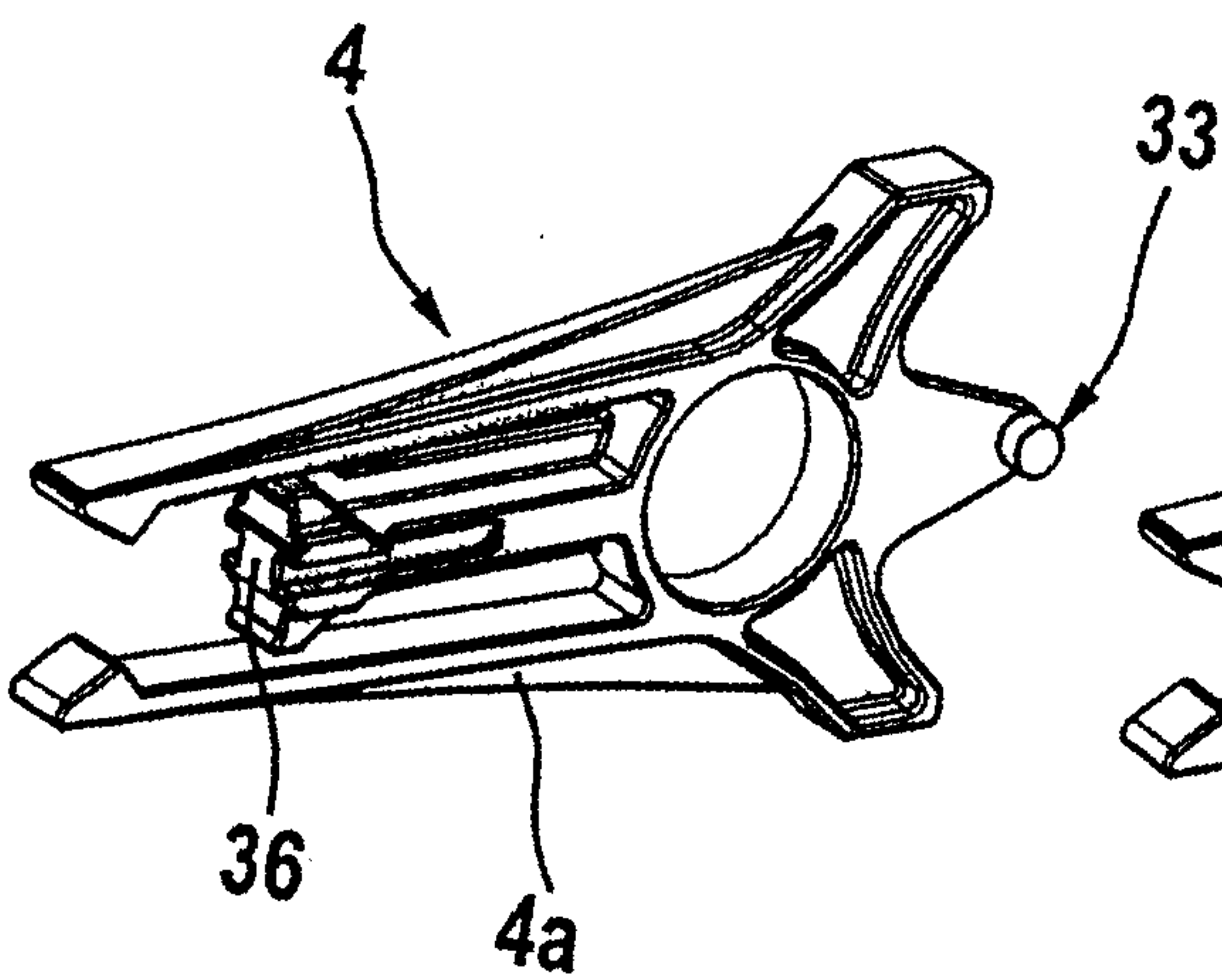
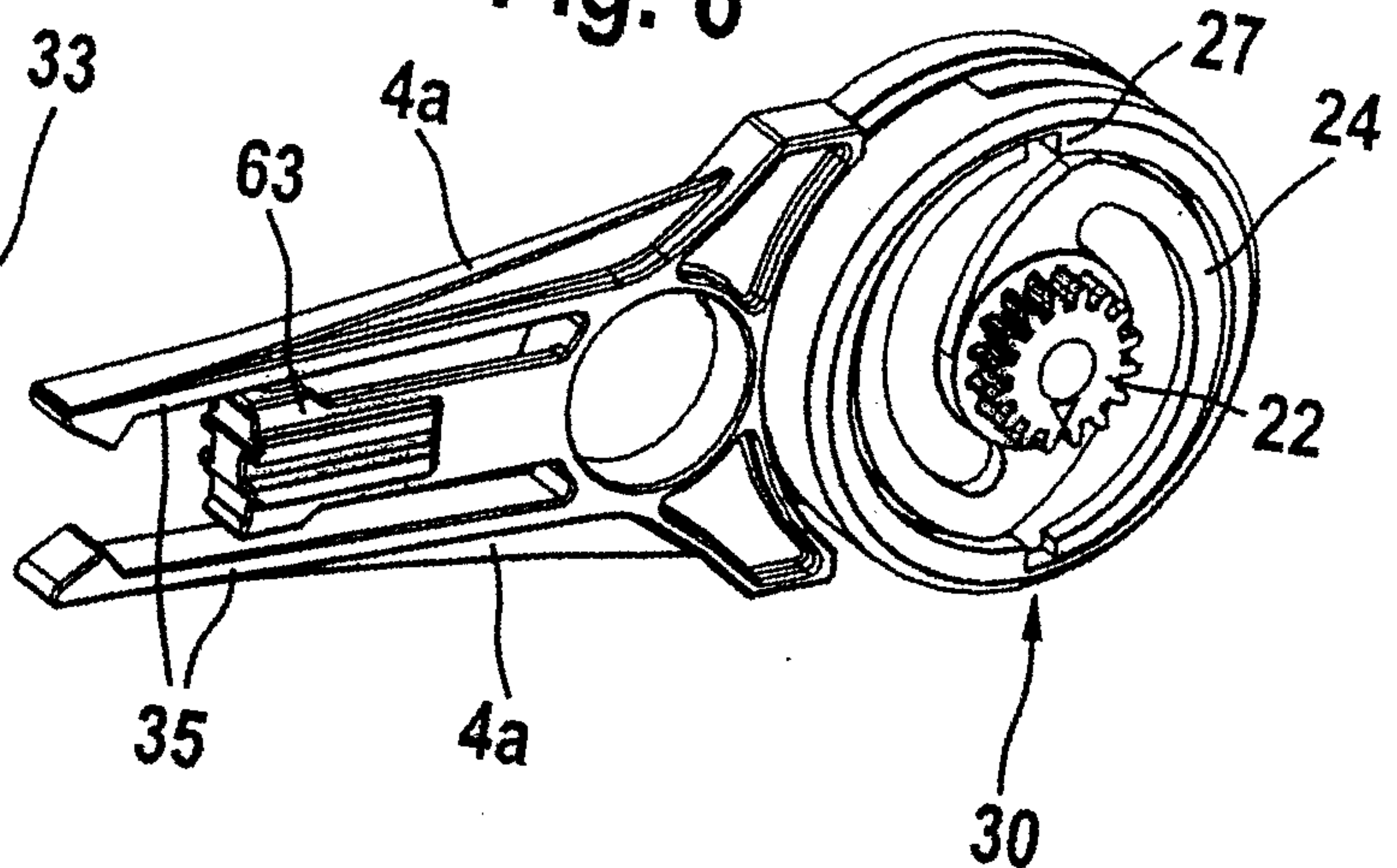

Fig. 6



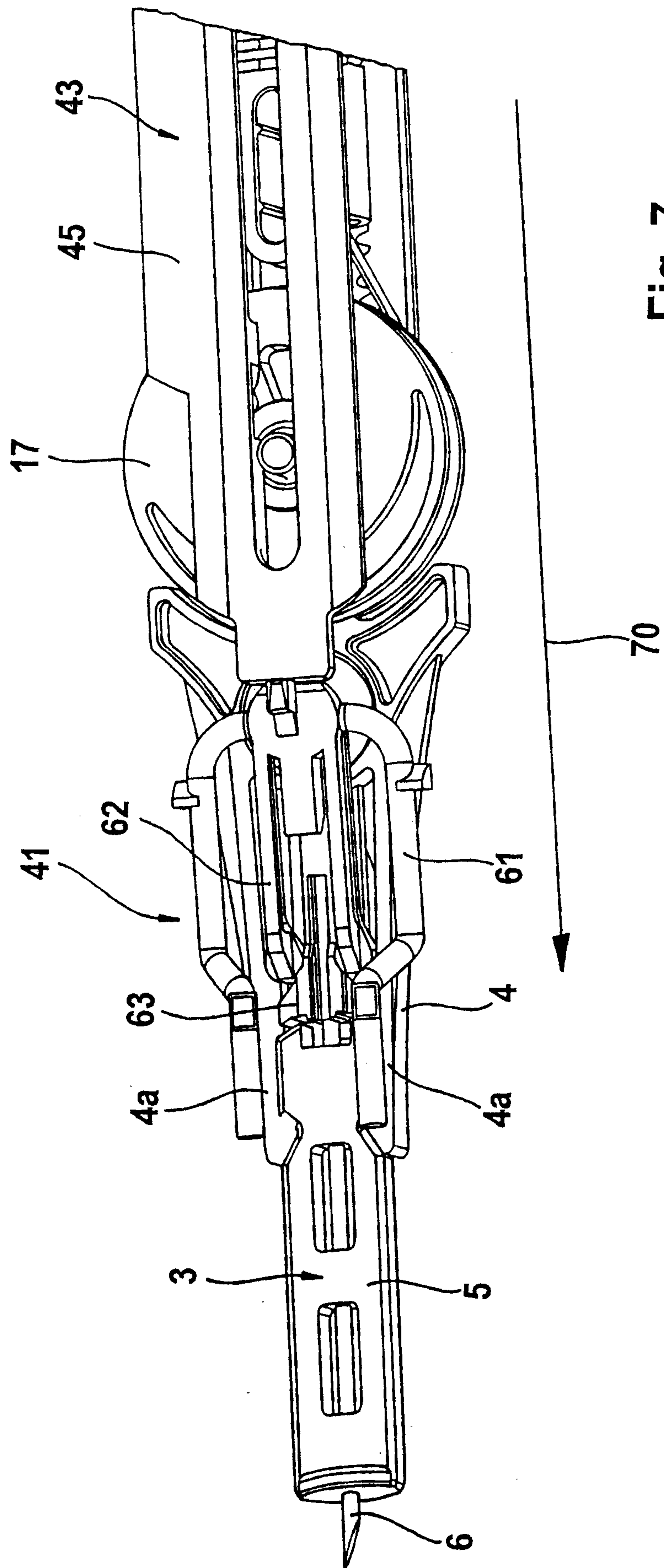

Fig. 7

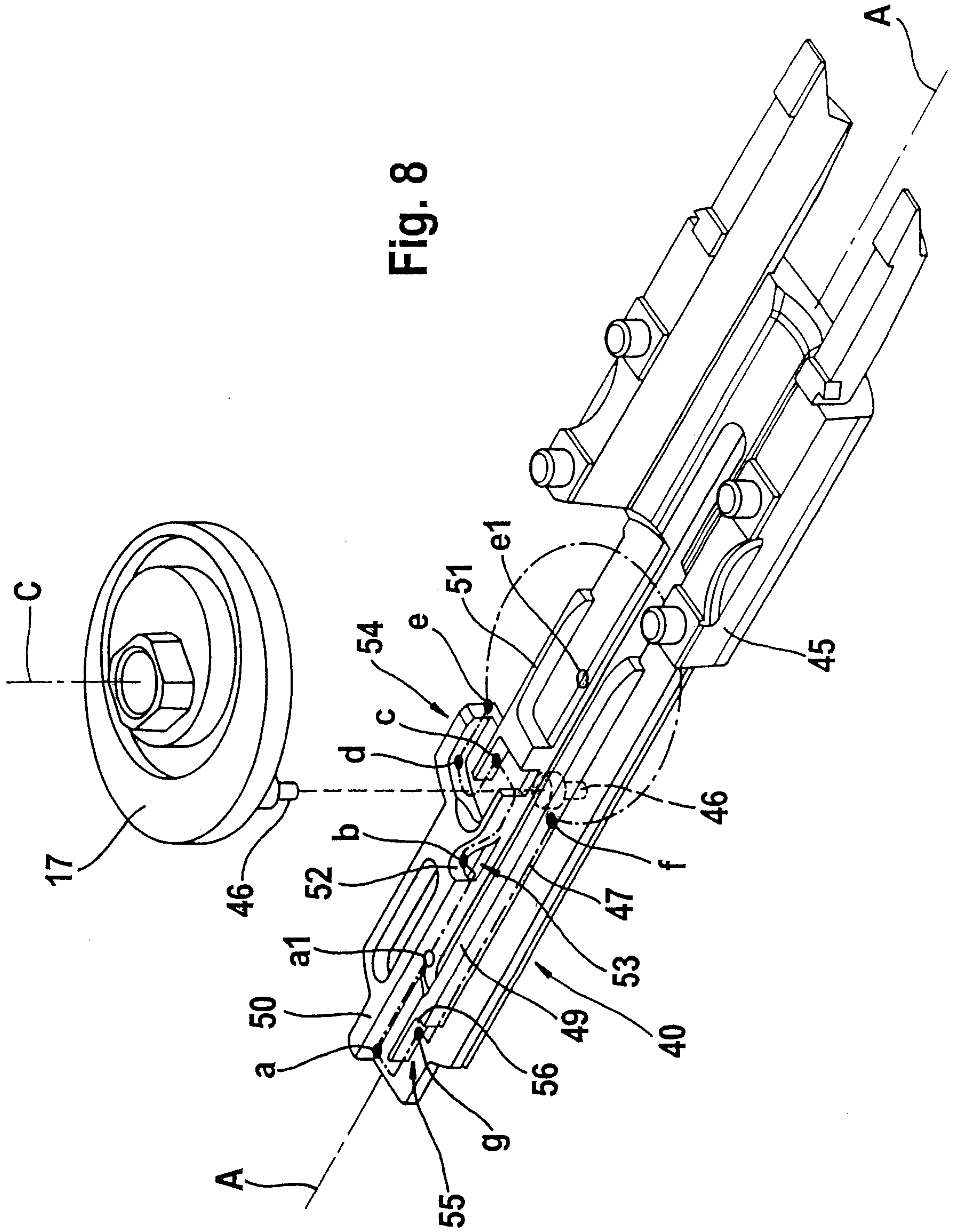

Fig. 8

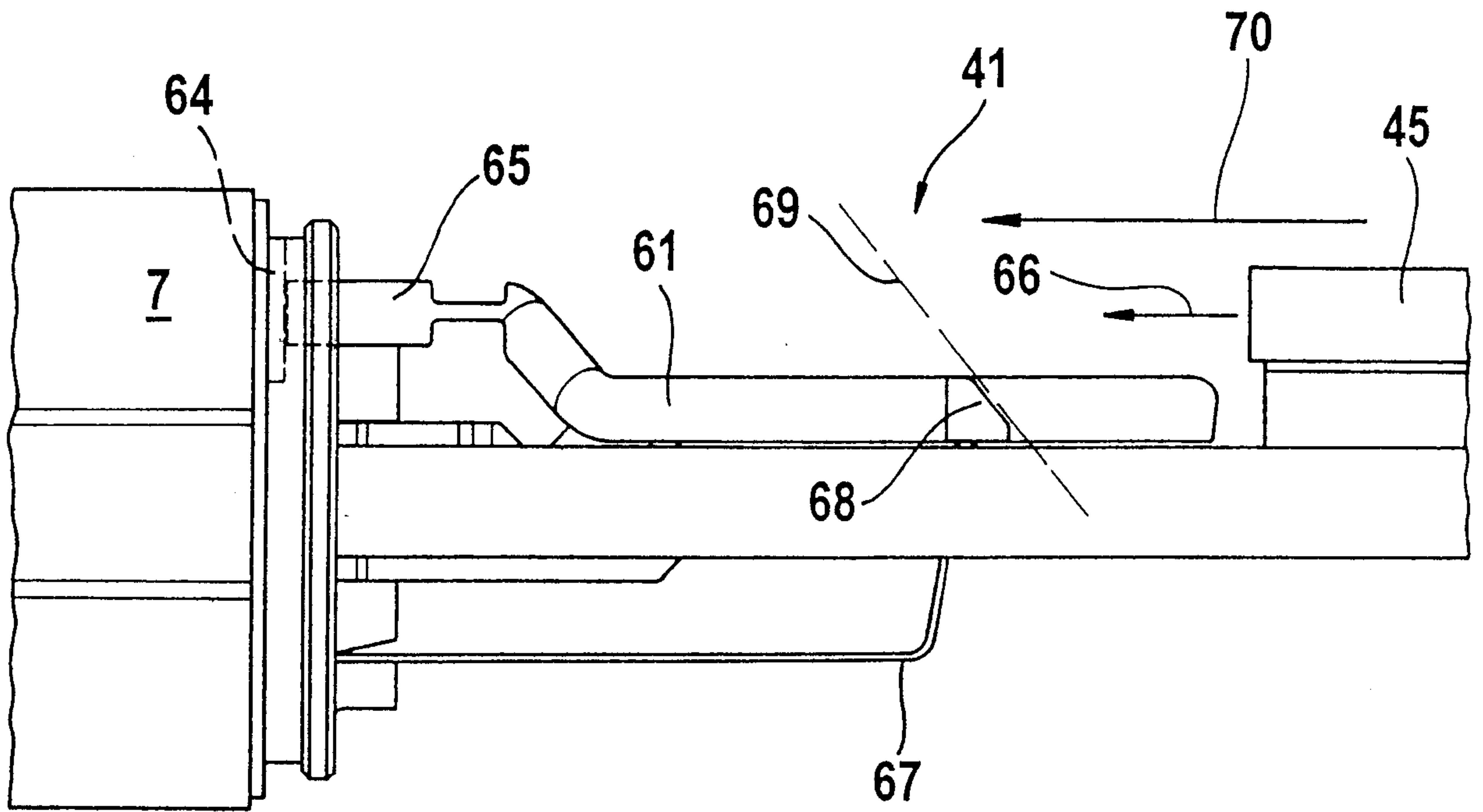

Fig. 9

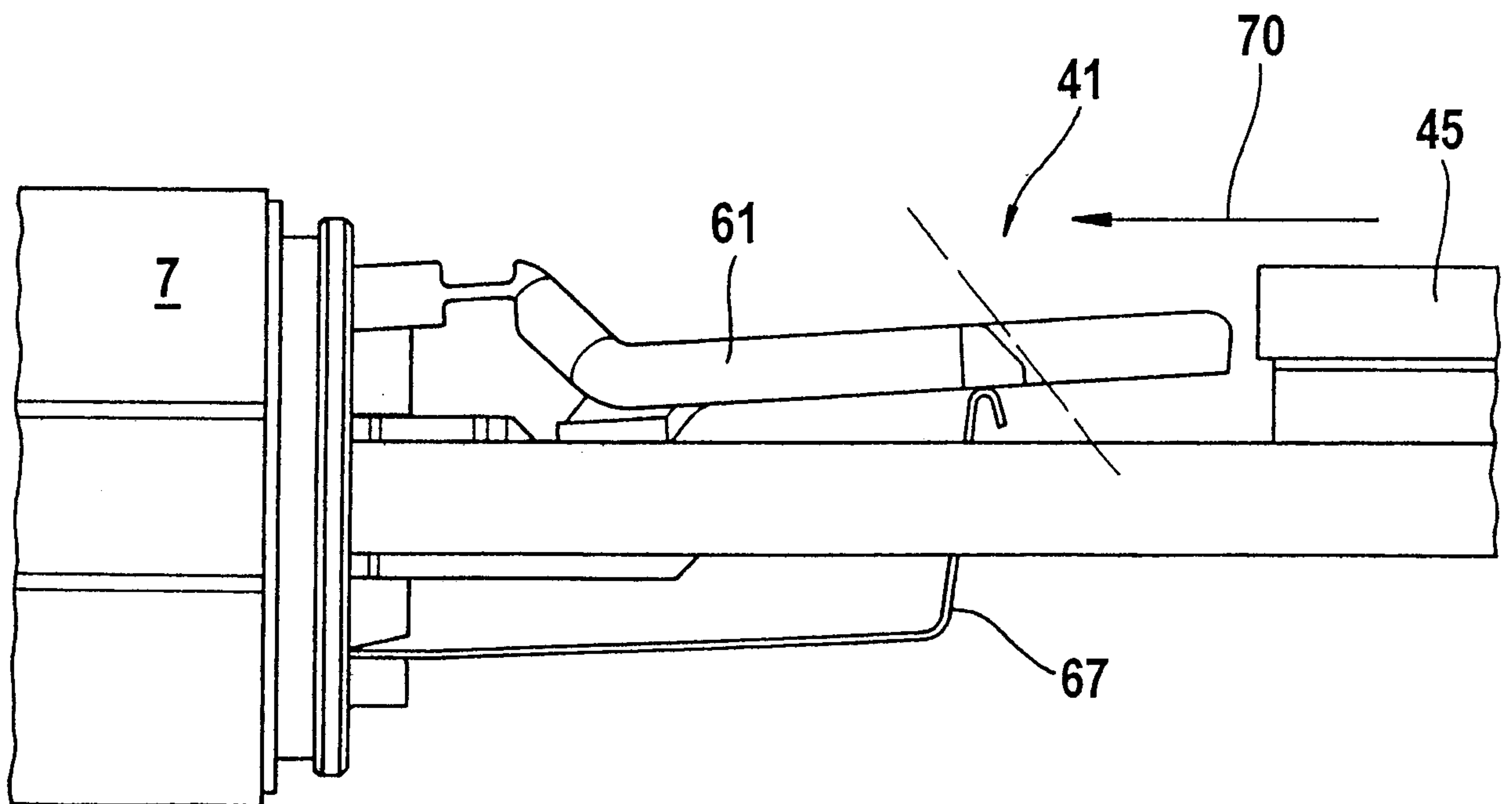

Fig. 10

