



- (51) International Patent Classification:
B24D 13/14 (2006.01) *B24B 7/18* (2006.01)
A47L 11/164 (2006.01) *B24B 7/14* (2006.01)
- (21) International Application Number: PCT/FI2012/050544
- (22) International Filing Date: 1 June 2012 (01.06.2012)
- (25) Filing Language: Finnish
- (26) Publication Language: English
- (30) Priority Data:
20115647 23 June 2011 (23.06.2011) FI
- (72) Inventor; and
- (71) Applicant : AHONEN, Mika [FI/FI]; Jänispolku 6, FI-39200 Kyröskoski (FI).
- (74) Agent: KANGASMÄKI, Reijo; Finnish Patent Consulting FPC, PL 25, FI-33401 Tampere (FI).
- (81) Designated States (*unless otherwise indicated, for every kind of national protection available*): AE, AG, AL, AM,

AO, AT, AU, AZ, BA, BB, BG, BH, BR, BW, BY, BZ, CA, CH, CL, CN, CO, CR, CU, CZ, DE, DK, DM, DO, DZ, EC, EE, EG, ES, FI, GB, GD, GE, GH, GM, GT, HN, HR, HU, ID, IL, IN, IS, JP, KE, KG, KM, KN, KP, KR, KZ, LA, LC, LK, LR, LS, LT, LU, LY, MA, MD, ME, MG, MK, MN, MW, MX, MY, MZ, NA, NG, NI, NO, NZ, OM, PE, PG, PH, PL, PT, QA, RO, RS, RU, RW, SC, SD, SE, SG, SK, SL, SM, ST, SV, SY, TH, TJ, TM, TN, TR, TT, TZ, UA, UG, US, UZ, VC, VN, ZA, ZM, ZW.

- (84) Designated States (*unless otherwise indicated, for every kind of regional protection available*): ARIPO (BW, GH, GM, KE, LR, LS, MW, MZ, NA, RW, SD, SL, SZ, TZ, UG, ZM, ZW), Eurasian (AM, AZ, BY, KG, KZ, RU, TJ, TM), European (AL, AT, BE, BG, CH, CY, CZ, DE, DK, EE, ES, FI, FR, GB, GR, HR, HU, IE, IS, IT, LT, LU, LV, MC, MK, MT, NL, NO, PL, PT, RO, RS, SE, SI, SK, SM, TR), OAPI (BF, BJ, CF, CG, CI, CM, GA, GN, GQ, GW, ML, MR, NE, SN, TD, TG).

Published: — with international search report (Art. 21(3))

(54) Title: ARRANGEMENT FOR FLOOR GRINDING

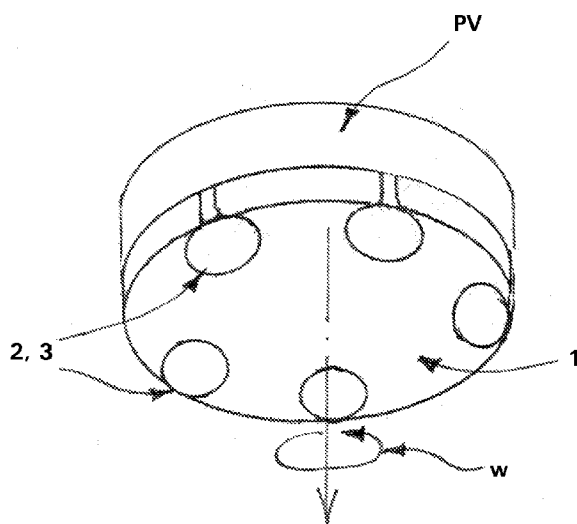

FIG. 6b

(57) Abstract: The invention relates to an arrangement for floor grinding, which is meant particularly for grinding of a floor with a floor conditioning device, such as a combination machine, floor conditioning machine or like. The arrangement comprises a tool instrument (1) to be used in the floor conditioning device by rotating (w) the same, the instrument being an essentially porous washing, polishing, waxing disk or like for carrying out basic functions of the floor conditioning device, and a grinding instrument (2), such as a diamond disk, to be coupled removably in connection with the tool instrument (1), or several of the kind, being essentially alike and being placed symmetrically in connection with the tool instrument (1). The arrangement comprises fastening means (3) in order to couple the grinding instrument (2) with the tool instrument (1) on the one hand by a fastening frame supported on its front surface and on the other hand by an auxiliary frame supported on its back surface.



Arrangement for floor grinding

5 The invention relates to an arrangement for floor
grinding, which is particularly meant for grinding of
a floor with a floor conditioning device, such as a
combination machine, floor conditioning machine or
like. The arrangement comprises a tool instrument to be
used in the floor conditioning device by rotating the
10 same, the instrument being an essentially porous
washing, polishing, waxing disk or like for carrying
out basic functions of the floor conditioning device,
and a grinding instrument, such as a diamond disk, to
be coupled removably in connection with the tool
15 instrument, or preferably several of the kind, being
essentially alike and being placed symmetrically in
connection with the tool instrument.

At present, in the above mentioned context, various
20 floor conditioning devices are being used for
conditioning and maintenance of most heterogeneous
floor surfaces. Combination machines in this context
refer to usually top-driven or pushable conditioning
machines with which e.g. washing of the floor with
25 water is possible to be executed in a way that also
water can be sucked from the floor with the machine.
There may be several rotating disks in this type of a
combination machine. On the other hand, e.g. pushable
floor conditioning machines that use one rotating disk
30 are also being used.

Furthermore, for more efficient floor grinding e.g.
diamond disks that are coupled removably e.g. to the
bottom surface of an ordinary washing, polishing or
35 waxing disk used for floor conditioning are known to be
exploited in connection with the above mentioned device
types. In this way, thanks to the diamond disks
attached to the disk, the same also may be used for

more efficient floor grinding in addition to basic washing and conditioning procedures. For their part, in use, there are usually structurally two types of diamond disks, ie. metal bond diamond disks and on the other hand plastic bond diamond disks. Furthermore, at present in this context the diamond disks are known to be connected at simplest by e.g. sticker tape attachment to the bottom surface of a porous tool instrument, like e.g. a washing disk, in addition to which today's novelty are diamond disks attached to the washing disk's bottom surface with glue that, however, do not anymore enable the washing disk to be used in its original purpose after removal of a diamond disk glued thereto.

The rotation speed of e.g. so called slow rotation floor conditioning machines varies typically between 150-500 rpm, whereas in so called fast rotation floor conditioning machines the rotation speed may even be above 900 rpm. Therefore coupling the diamond disks only to the bottom surface of the washing disk always imposes a risk, as the diamond disk may dart at a high speed in case the washing disk is worn out, the sticker tape attachment is so to speak pilled or the glueing of the diamond disk fails, therefore imposing a work safety risk in addition to other possible damages caused.

It is an aim of the arrangement for floor grinding according to the present invention to achieve a decisive improvement in the problems described above and thus to raise essentially the level of prior art. In order to carry out this aim, the arrangement according to the invention is mainly characterized by that it comprises fastening means in order to couple the grinding instrument with the tool instrument on the one hand by a fastening frame supported on its front

surface and on the other hand by an auxiliary frame supported on its back surface.

5 As the most important advantages of the arrangement according to the invention are the simplicity and efficiency of the structures related thereto and use thereof, thanks to one or more grinding instruments, such as diamond disks, being couplable for use in a fast and reliable manner thanks to two-sided fastening
10 thereof to the tool instrument without the risk of e.g. inadvertent detachment of a diamond disk during grinding. The fastening means according to the invention may advantageously be implemented e.g. as a compound structure entirety made of a elastic/flexible
15 material reaching to the opposite sides of the tool instrument.

Therefore, thanks to the invention, a grinding instrument, e.g. a diamond disk, suitable for the
20 purpose at any given time may be coupled to e.g. a washing disk in an easily attachable manner and removably without breaking of the washing disk in a way that the disk is as a further advantageous embodiment locked with the washing disk e.g. by anchoring means
25 passing through the disk and/or by retaining means in the opposite attachment and auxiliary frames getting pressed onto the washing disk's outer and inner surfaces. With a coupling of the tool instrument and the grinding instrument/instruments implemented
30 according to the arrangement of the invention, the floor conditioning procedures may be intensified decisively improving work safety at the same time.

35 Other advantageous embodiments of the arrangement according to the invention have been presented in the dependent claims related thereto.

In the following description, the invention is illustrated in detail with reference to the appended drawings, in which

5 in figures 1a-1c
 are shown a bottom view, a cross-section view
 and an upper view of an advantageous
 arrangement according to the invention,

10 in figures 2a-2c
 are shown views according to figure 1 of
 another alternative arrangement according to
 the invention,

15 in figures 3a-3c
 are shown views according to figure 1 of a
 third alternative arrangement according to
 the invention,

20 in figures 4a-4c
 are shown views according to figure 1 of a
 fourth alternative arrangement according to
 the invention,

25 in figures 5a-5c
 are furthermore shown views according to
 figure 1 of a fifth alternative arrangement
 according to the invention, and furthermore

30 in figures 6a and 6b
 is firstly shown coupling of a waxing disk
 equipped with grinding instruments, being
 coupled therewith by fastening means
 according to the invention, to a floor
35 conditioning device's pull platform, and on
 the other hand there is shown usage of the
 above mentioned combination in floor
 grinding.

The invention relates to an arrangement for floor grinding, which is particularly meant for grinding of a floor with a floor conditioning device, such as a combination machine, floor conditioning machine or like. The arrangement comprises a tool instrument 1 to be used in the floor conditioning device by rotating w
5 the same, the instrument being an essentially porous washing, polishing, waxing disk or like for carrying out basic functions of the floor conditioning device, and a grinding instrument 2, such as a diamond disk, to
10 be coupled removably in connection with the tool instrument 1, or preferably several of the kind, being essentially alike and being placed symmetrically in connection with the tool instrument 1. The arrangement
15 comprises fastening means 3 in order to couple the grinding instrument 2 with the tool instrument 1 on the one hand by a fastening frame 3a supported on its front surface 1a and on the other hand by an auxiliary frame 3b supported on its back surface 1b.

20 In figure 6a is shown an advantageous embodiment of the arrangement according to the invention, in which a waxing disk 1 equipped with grinding instruments 2, being coupled therewith by fastening means 3 according
25 to the invention, is being coupled with e.g. an ordinary floor conditioning device's pull platform PV, the fastening surface K of which typically comprises hundreds of small spikes. When the waxing disk 1 is pushed against this fastening surface, the tool
30 instrument 1 gets stuck on its place as the spikes on the fastening surface K penetrate the porous waxing disk. After this, the waxing disk equipped with e.g. diamond disks may therefore be used for floor grinding in a way depicted in figure 6b, the disk being rotated
35 w by the floor conditioning device.

The simplest embodiments of the invention are shown in figures 1a-1c and 2a-2c, in which the fastening means

3 comprise an auxiliary frame 3b attached on the washing disk's back surface 1b, the auxiliary frame being directly couplable with the fastening frame 3a arranged in connection with the grinding instrument 2, such as a diamond disk, on the washing disk's front surface.

As an advantageous embodiment of the arrangement according to the invention with reference to the alternative embodiments shown in figures 3a-3c, 4a-4c and 5a-5c, the fastening means 3 belonging thereto comprise a fastening frame 3a that is separate to the grinding instrument 2 and supported on the tool instrument's front surface 1a and an auxiliary frame 3b supported on the tool instrument's back surface 1b.

Furthermore, as an advantageous embodiment particularly with reference to figures 1a-1c, 2a-2c and 3a-3c, the arrangement also comprises anchoring means 4 for coupling of the grinding instrument 2 and/or the fastening frame 3a removably with the auxiliary frame 3b. In this context it is advantageously also possible to use quick-release principle, such as a snap lock joint or the like.

Furthermore, as an advantageous embodiment particularly with reference to the alternatives shown in figures 1a-1c and 2a-2c, the auxiliary frame 3b of the fastening means 3 is carried out by a separate part.

Furthermore, as an advantageous embodiment particularly with reference to the alternative embodiments shown in figures 1a-1c, 2a-2c, 3a-3c, 4a-4c and 5a-5c, the fastening frame 3a of the fastening means 3 and the auxiliary frame 3b are arranged as a built-in entirety that extends on opposite sides of the tool instrument 1.

As a further advantageous embodiment, the anchoring means 4 comprise locking pins 4a provided with the grinding instrument, the fastening frame and/or the auxiliary frame 2, 3a, 3b in a built-in manner and going through the tool instrument 1, for getting locked with counterpart surfaces 4b existing in an opposite part 3b, 3a, 2.

As a further advantageous embodiment particularly with reference to the alternatives shown in figures 4a-4c and 5a-5c, the grinding instrument 2, the fastening frame 3a and/or the auxiliary frame 3b is/are provided with retaining means 5 that protrude inside the tool instrument 1 through its front and/or back surface 1a, 1b.

As a further advantageous embodiment particularly with reference to the alternatives shown in figures 3a-3c, 4a-4c and 5a-5c, the fastening frame 3a of the fastening means 3 is provided with means 6 for fastening of the grinding instrument 2 to the same chemically, such as by glueing, mechanically, such as by sticker gripping or snap lock jointing, melting, such as by welding, and/or in a corresponding manner.

Particularly in the advantageous embodiments shown in figures 3a-3c, 4a-4c and 5a-5c, the fastening means 3 are arranged as a built-in entirety extending on opposite sides of the tool instrument 1 and being manufactured from elastic/flexible material, wherein the fastening and the auxiliary frames 3a, 3b positioned against the front and back surfaces 1a, 1b of the tool instrument, are provided as a furthermore advantageous embodiment with e.g. retaining means 5 extending inside the tool instrument.

Furthermore, in the advantageous embodiment shown in figures 5a-5c, the fastening frame 3a of the fastening

means 3 is provided with an opening A at a corresponding point as the auxiliary frame 3b, when viewed in a direction of height h perpendicular to a plane defined by the tool instrument 1. In this manner
5 minimizing of the amount of material needed for manufacturing the fastening means is enabled.

It is clear that the invention is not limited to the embodiments shown or described above, but it can be
10 modified within the basic idea of the invention in very many ways, e.g. by combining the embodiments shown in the appended figures together etc. Also the types of implementations that are mentioned above may be
15 executed structurally in different ways regarding structure or appearance thereof etc. than what is described above. The part entireties of the arrangement according to the invention may in addition be
20 manufactured from a variety of materials, exploiting a variety of manufacturing techniques using plastic, ceramic, composite, carbon fibre materials or the like, without forgetting metal structures, such as light alloy implementations.

Claims:

1. Arrangement for floor grinding, which is particularly meant for grinding of a floor with a floor conditioning device, such as a combination machine, floor conditioning machine or like, whereby the arrangement comprises a tool instrument (1) to be used in the floor conditioning device by rotating (w) the same, the instrument being an essentially porous washing, polishing, waxing disk or like for carrying out basic functions of the floor conditioning device, and a grinding instrument (2), such as a diamond disk, to be coupled removably in connection with the tool instrument (1), or preferably several of the kind, being essentially alike and being placed symmetrically in connection with the tool instrument (1), **characterized** in that the arrangement comprises fastening means (3) in order to couple the grinding instrument (2) with the tool instrument (1) on the one hand by a fastening frame (3a) supported on its front surface (1a) and on the other hand by an auxiliary frame (3b) supported on its back surface (1b).

2. Arrangement according to claim 1, **characterized** in that, it comprises anchoring means (4) for coupling of the grinding instrument (2) and/or the fastening frame (3a) removably with the auxiliary frame (3b).

3. Arrangement according to claim 2, **characterized** in that, the anchoring means (4) are arranged to be locked on quick-release principle, such as by a snap lock joint, or correspondingly.

4. Arrangement according to any of the preceding claims 1-3, **characterized** in that auxiliary frame (3b) of the fastening means (3) is carried out by a separate part.

5. Arrangement according to any of the preceding claims 1-3, **characterized** in that, the fastening frame (3a) of the fastening means (3) and the auxiliary frame (3b) are arranged as a built-in entirety that extends on opposite sides of the tool instrument (1).

6. Arrangement according to any of the preceding claims 2-5, **characterized** in that, the anchoring means (4) comprise locking means (4a) provided with the grinding instrument, the fastening frame and/or the auxiliary frame (2, 3a, 3b) in a built-in manner and going through the tool instrument (1), for getting locked with counterpart means (4b) existing in an opposite part (3b, 3a, 2).

7. Arrangement according to any of the preceding claims 1-6, **characterized** in that, the grinding instrument (2), the fastening frame (3a) and/or the auxiliary frame (3b) is/are provided with retaining means (5) that protrude inside the tool instrument (1) through its front and/or back surface (1a, 1b).

8. Arrangement according to any of the preceding claims 1-7, **characterized** in that, the fastening frame (3a) of the fastening means (3) is provided with means (6) for fastening of the grinding instrument (2) to the same chemically, such as by glueing, mechanically, such as by sticker gripping or snap lock jointing, melting, such as by welding, and/or in a corresponding manner.

9. Arrangement according to any of the preceding claims 1-8, **characterized** in that, the fastening means (3) are arranged as a built-in entirety extending on opposite sides of the tool instrument (1) and being manufactured from elastic/flexible material, wherein the fastening and the auxiliary frames (3a, 3b) positioned against the front and back surfaces (1a, 1b) of the tool instrument, are provided with retaining

means (5) preferably extending inside the tool instrument.

10. Arrangement according to claim 9,
5 **characterized** in that, the fastening frame (3a) of the fastening means (3) is provided with an opening (A) at a corresponding point as the auxiliary frame (3b), when viewed in a direction of height (h) perpendicular to a plane defined by the tool instrument (1).

10

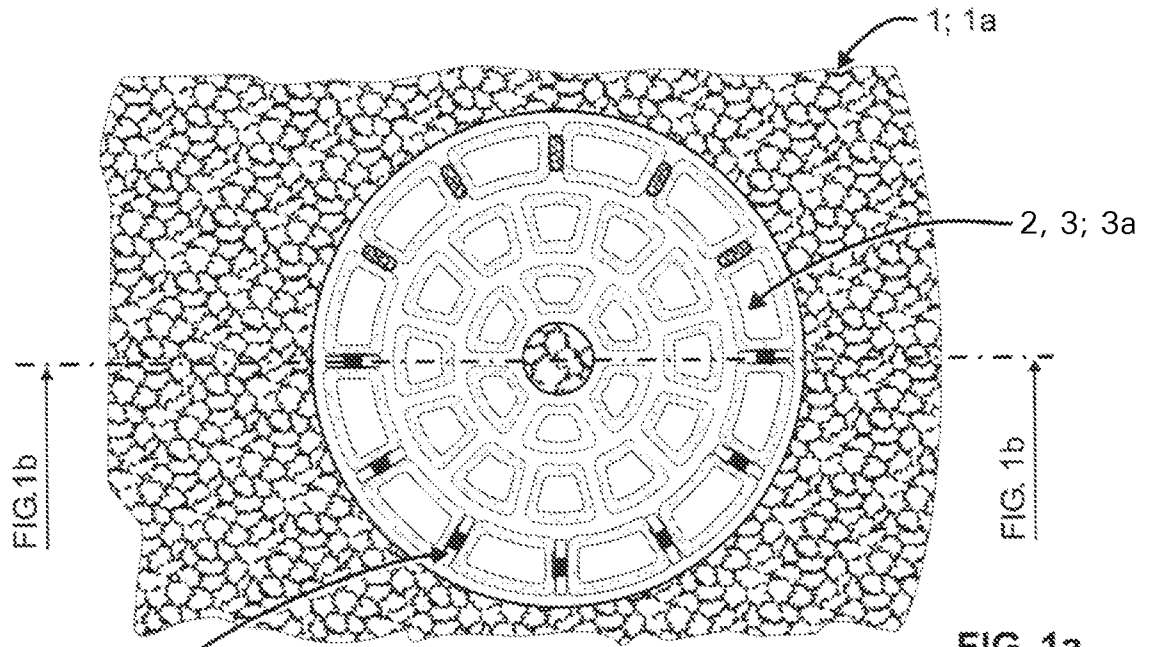

FIG. 1a

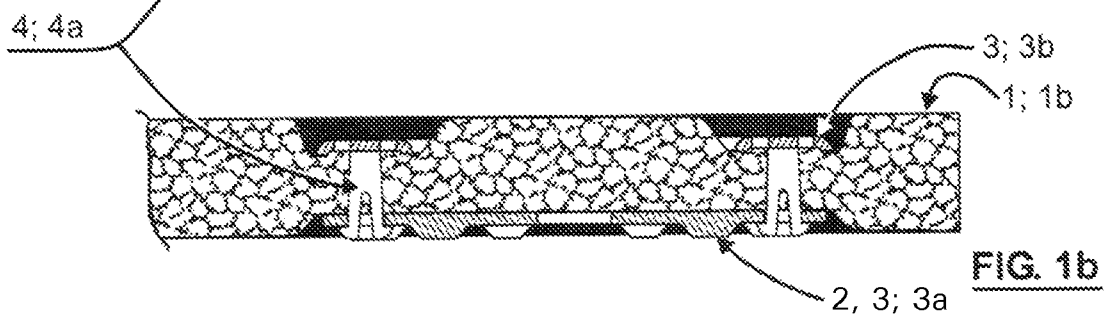

FIG. 1b

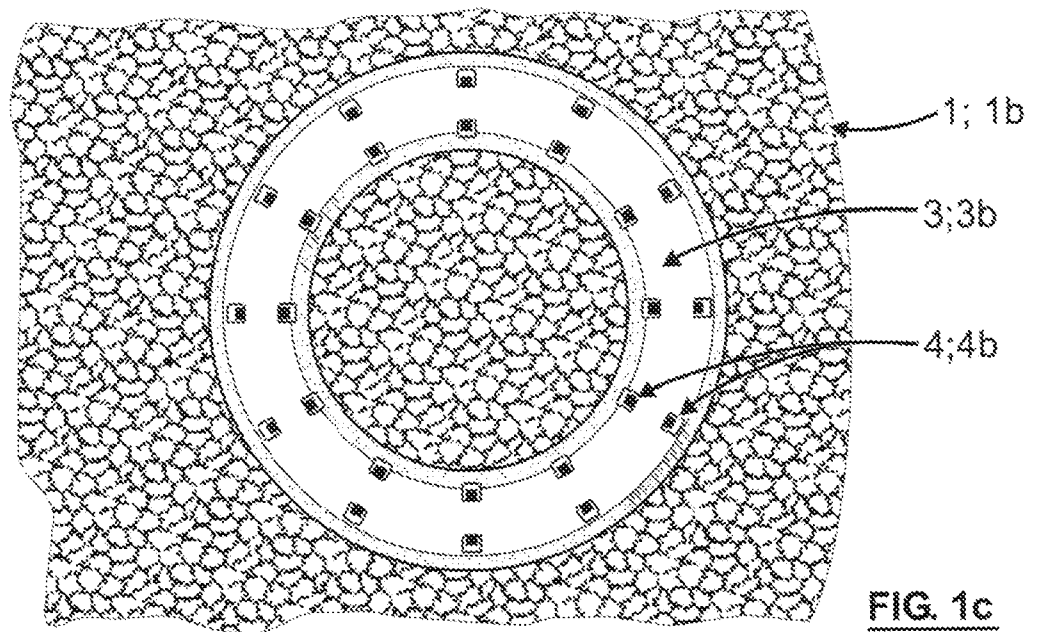

FIG. 1c

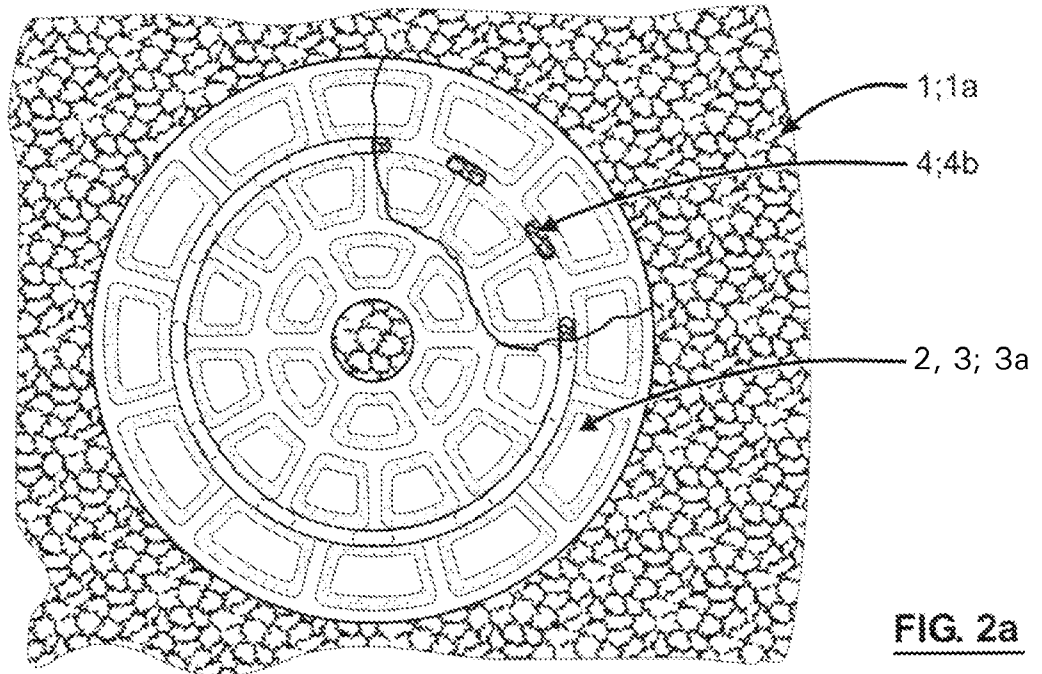

FIG. 2a

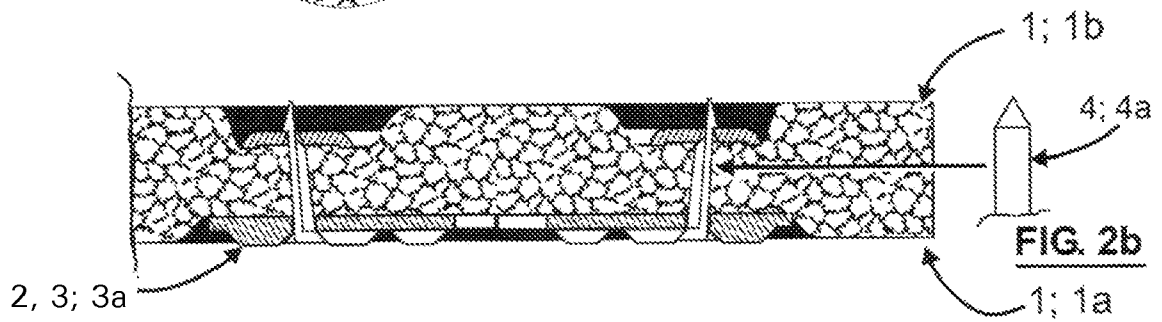

FIG. 2b

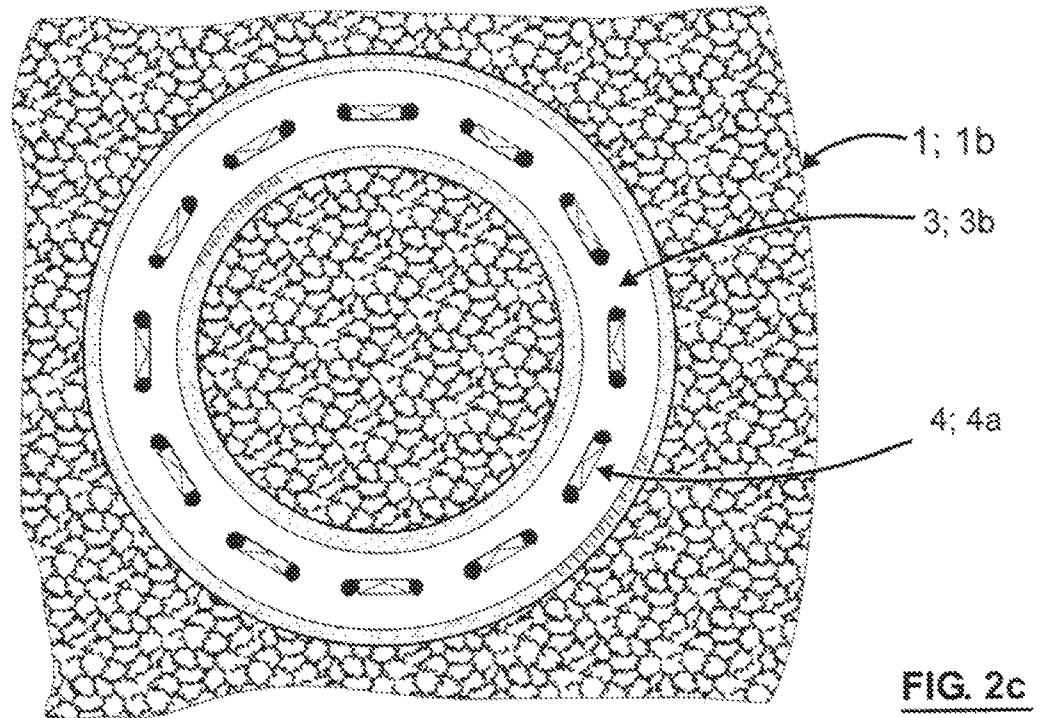

FIG. 2c

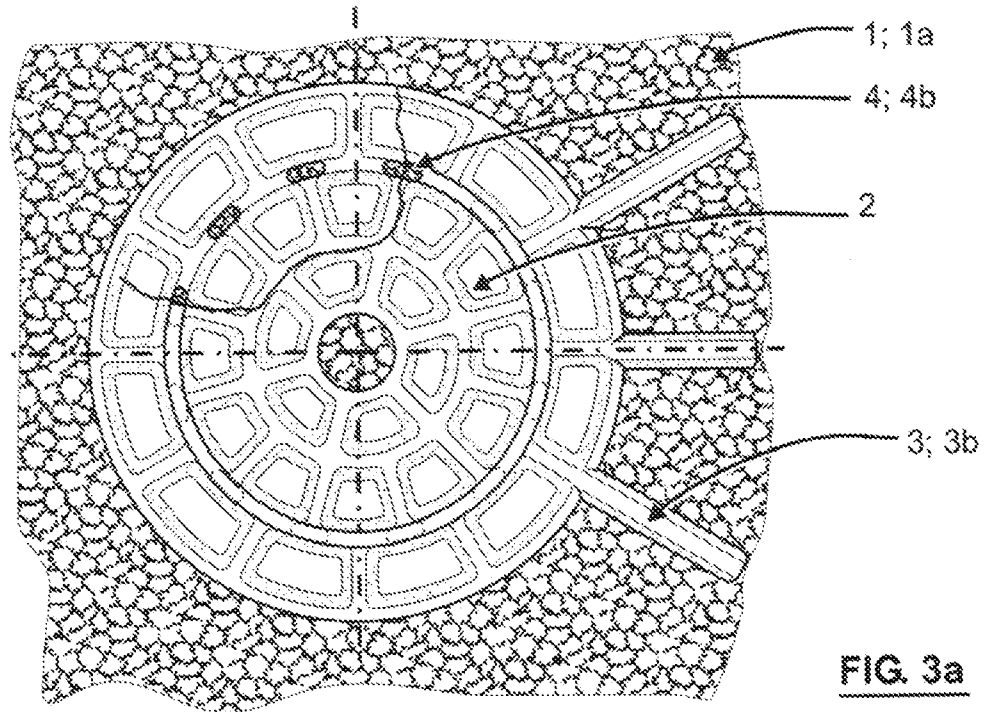

FIG. 3a

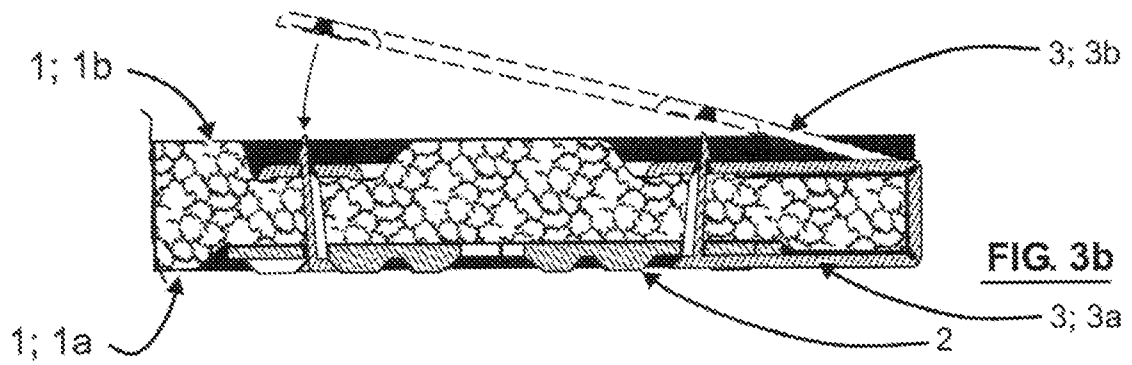

FIG. 3b

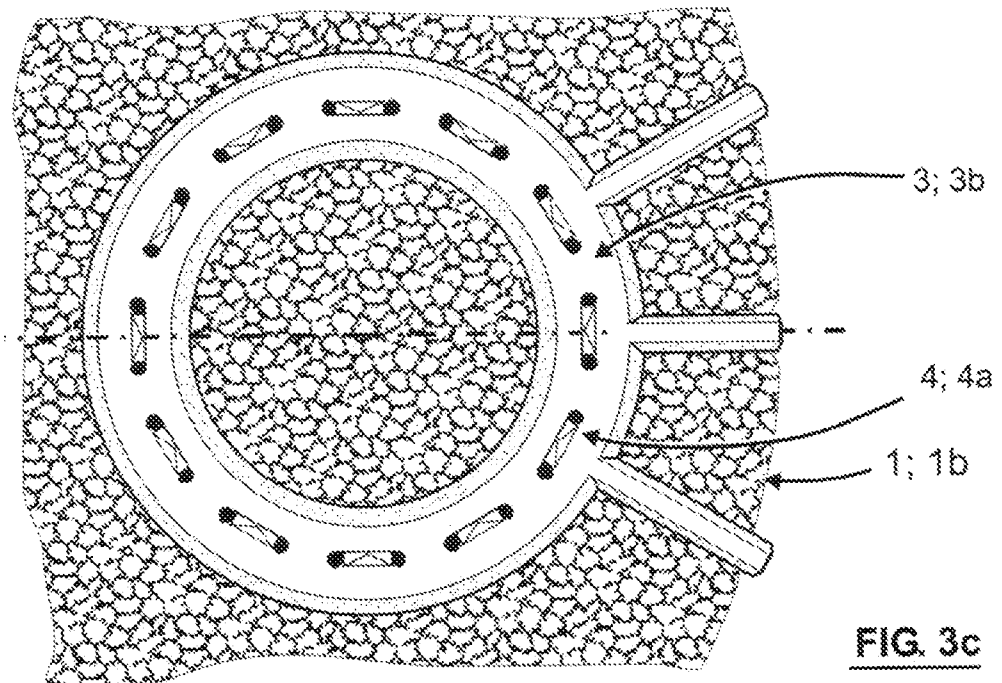

FIG. 3c

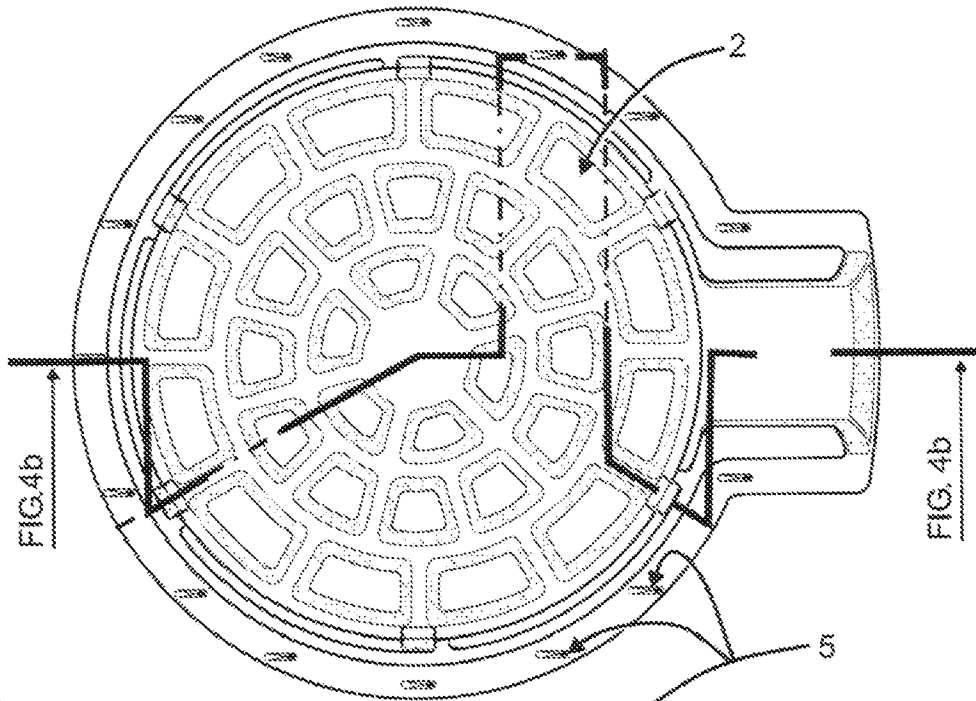

FIG. 4a

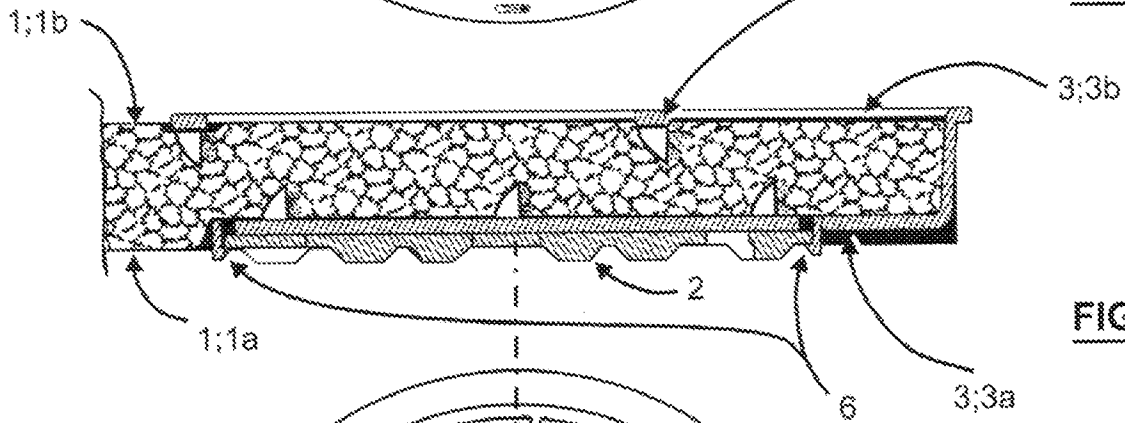

FIG. 4b

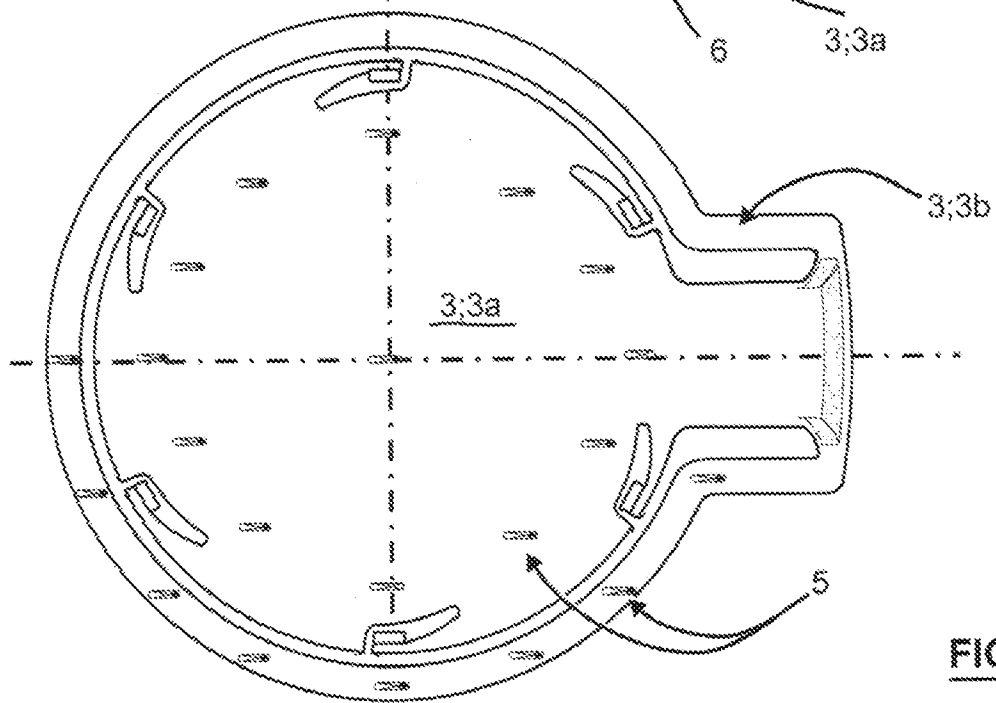

FIG. 4c

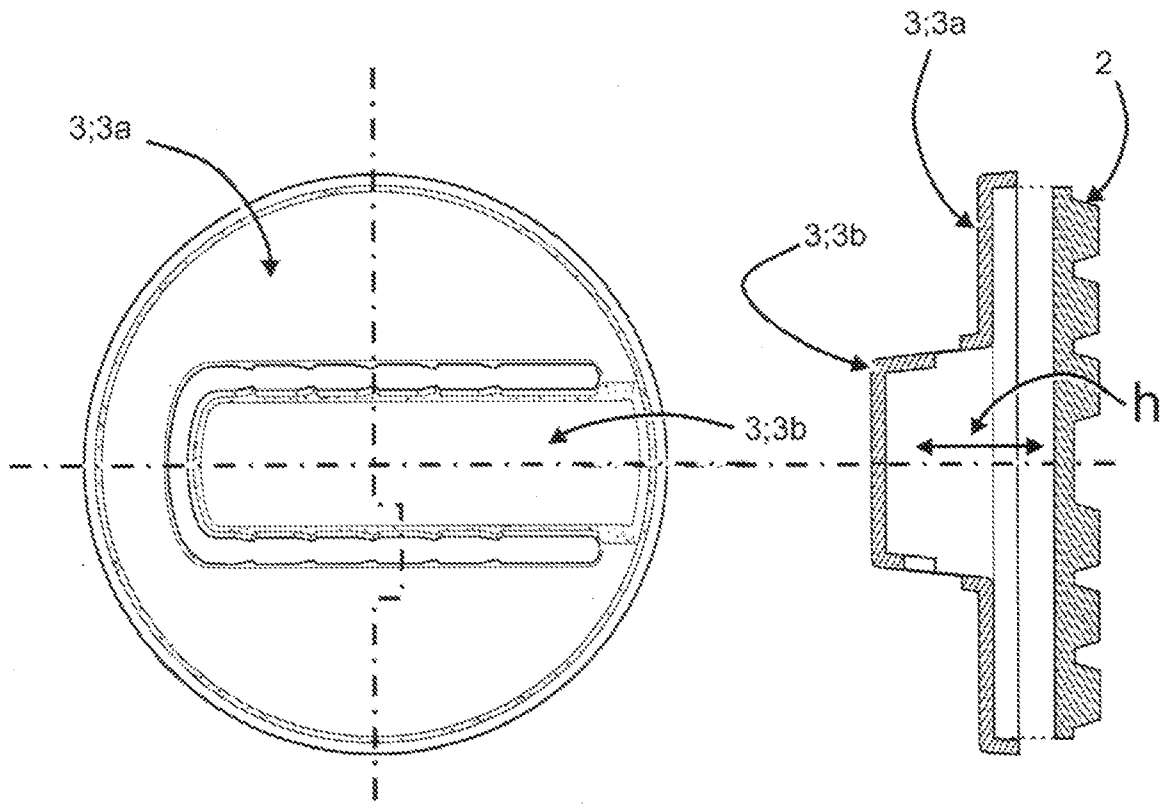

FIG. 5a

FIG. 5b

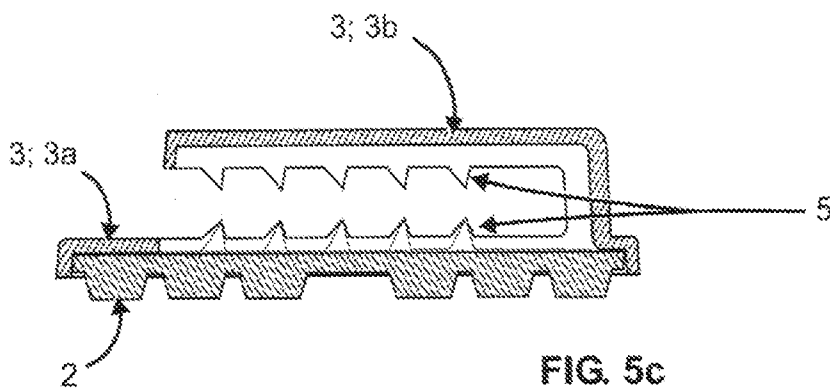

FIG. 5c

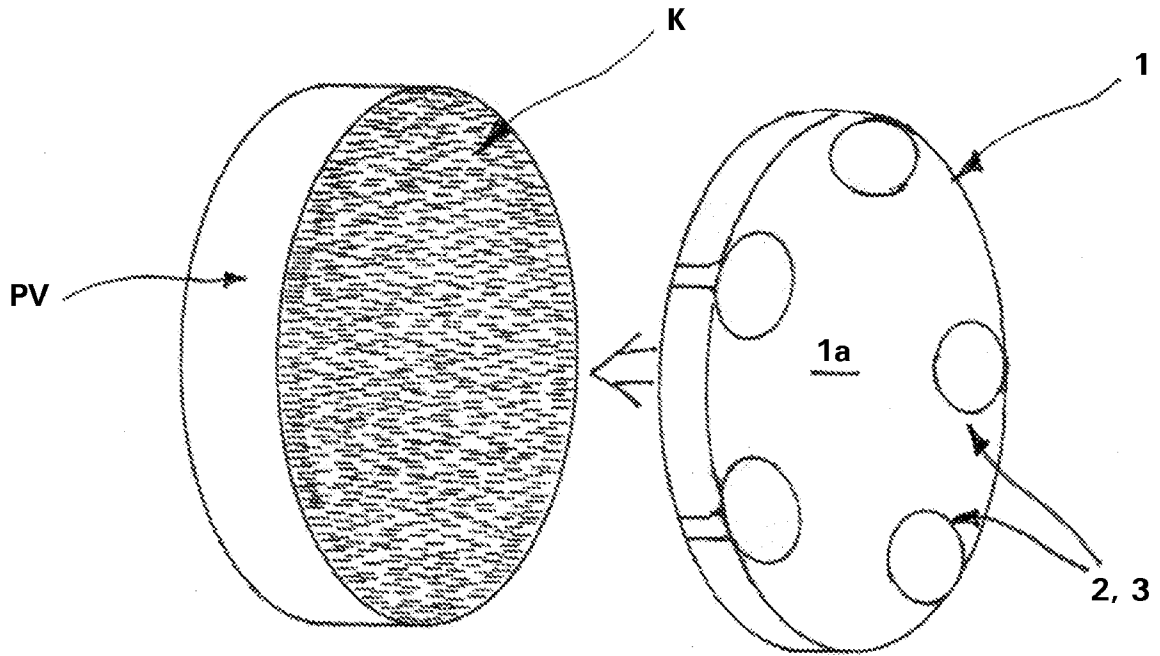

FIG. 6a

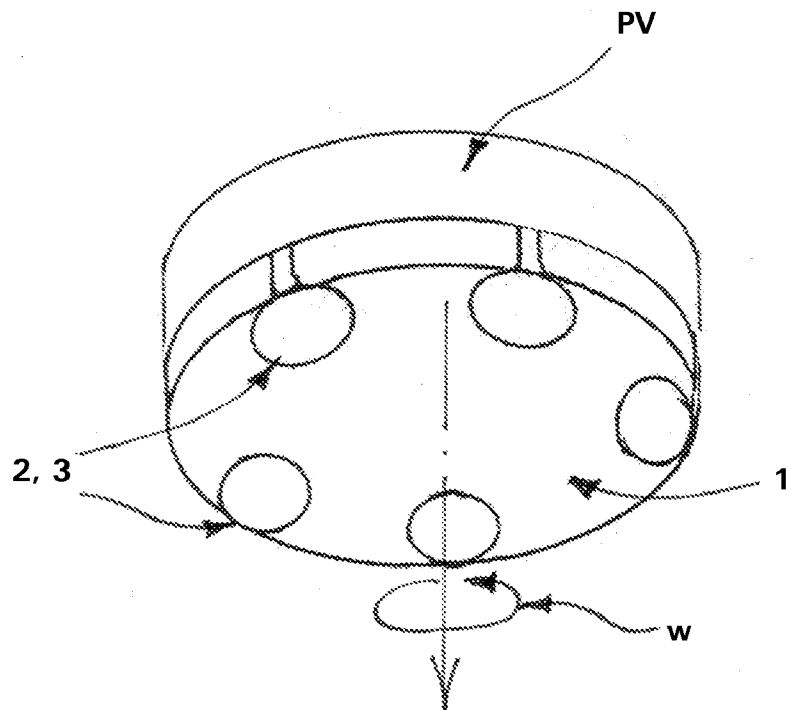

FIG. 6b

INTERNATIONAL SEARCH REPORT

International application No.
PCT/FI2012/050544

A. CLASSIFICATION OF SUBJECT MATTER

IPC: see extra sheet

According to International Patent Classification (IPC) or to both national classification and IPC

B. FIELDS SEARCHED

Minimum documentation searched (classification system followed by classification symbols)

IPC: A47L, B24B, B24D

Documentation searched other than minimum documentation to the extent that such documents are included in the fields searched

SE, DK, FI, NO classes as above

Electronic data base consulted during the international search (name of data base and, where practicable, search terms used)

EPO-Internal, PAJ, WPI data

C. DOCUMENTS CONSIDERED TO BE RELEVANT

Category*	Citation of document, with indication, where appropriate, of the relevant passages	Relevant to claim No.
A	WO 9850198 A2 (MEGUIAR S INC), 12 November 1998 (1998-11-12); abstract; figures --	1-10
A	WO 9107902 A1 (HOME HYGIENE LTD), 13 June 1991 (1991-06-13); abstract; figures --	1-10
A	CN 201350051 Y (JIELONG HU), 25 November 2009 (2009-11-25); abstract; figures 2-6 --	1-10
A	US 20080072386 A1 (THE MALISH CORPORATION), 27 March 2008 (2008-03-27); abstract; figures --	1-10

Further documents are listed in the continuation of Box C.

See patent family annex.

* Special categories of cited documents:

“A” document defining the general state of the art which is not considered to be of particular relevance
 “E” earlier application or patent but published on or after the international filing date
 “L” document which may throw doubts on priority claim(s) or which is cited to establish the publication date of another citation or other special reason (as specified)
 “O” document referring to an oral disclosure, use, exhibition or other means
 “P” document published prior to the international filing date but later than the priority date claimed

“T” later document published after the international filing date or priority date and not in conflict with the application but cited to understand the principle or theory underlying the invention
 “X” document of particular relevance; the claimed invention cannot be considered novel or cannot be considered to involve an inventive step when the document is taken alone
 “Y” document of particular relevance; the claimed invention cannot be considered to involve an inventive step when the document is combined with one or more other such documents, such combination being obvious to a person skilled in the art
 “&” document member of the same patent family

Date of the actual completion of the international search

02-10-2012

Date of mailing of the international search report

03-10-2012

Name and mailing address of the ISA/SE

Patent- och registreringsverket
 Box 5055
 S-102 42 STOCKHOLM
 Facsimile No. + 46 8 666 02 86

Authorized officer

Fredrik Strand

Telephone No. + 46 8 782 25 00

INTERNATIONAL SEARCH REPORTInternational application No.
PCT/FI2012/050544

C (Continuation). DOCUMENTS CONSIDERED TO BE RELEVANT

Category*	Citation of document, with indication, where appropriate, of the relevant passages	Relevant to claim No.
A	DE 102008052824 A1 (FLEX ELEKTROWERKZEUGE GMBH), 22 April 2010 (2010-04-22); abstract; figures -- -----	1-10

Continuation of: second sheet

International Patent Classification (IPC)

B24D 13/14 (2006.01)

A47L 11/164 (2006.01)

B24B 7/18 (2006.01)

B24D 7/14 (2006.01)

Download your patent documents at www.prv.se

The cited patent documents can be downloaded:

- From "Cited documents" found under our online services at www.prv.se
(English version)
- From "Anförda dokument" found under "e-tjänster" at www.prv.se
(Swedish version)

Use the application number as username. The password is **SZRKGMVJH**.

Paper copies can be ordered at a cost of 50 SEK per copy from PRV InterPat (telephone number 08-782 28 85).

Cited literature, if any, will be enclosed in paper form.

INTERNATIONAL SEARCH REPORT

Information on patent family members

International application No.

PCT/FI2012/050544

WO	9850198 A2	12/11/1998	AT	301022 T	15/08/2005
			AU	732843 B2	03/05/2001
			AU	7478598 A	27/11/1998
			CA	2288829 A1	12/11/1998
			DE	69831089 T2	08/06/2006
			EP	1024924 A4	28/05/2003
			US	5944586 A	31/08/1999
WO	9107902 A1	13/06/1991	AU	5289590 A	26/06/1991
			CA	2020914 A1	25/05/1991
			DE	9002860 U1	23/08/1990
			EP	0455751 A1	13/11/1991
			FR	2654967 A3	31/05/1991
			GB	2238263 A	29/05/1991
			IT	9035694 U1	25/05/1991
			IT	220706 Z2	02/11/1993
CN	201350051 Y	25/11/2009	NONE		
US	20080072386 A1	27/03/2008	NONE		
DE	102008052824 A1	22/04/2010	NONE		