

FOR THE PURPOSES OF INFORMATION ONLY

Codes used to identify States party to the PCT on the front pages of pamphlets publishing international applications under the PCT.

AL	Albania	ES	Spain	LS	Lesotho	SI	Slovenia
AM	Armenia	FI	Finland	LT	Lithuania	SK	Slovakia
AT	Austria	FR	France	LU	Luxembourg	SN	Senegal
AU	Australia	GA	Gabon	LV	Latvia	SZ	Swaziland
AZ	Azerbaijan	GB	United Kingdom	MC	Monaco	TD	Chad
BA	Bosnia and Herzegovina	GE	Georgia	MD	Republic of Moldova	TG	Togo
BB	Barbados	GH	Ghana	MG	Madagascar	TJ	Tajikistan
BE	Belgium	GN	Guinea	MK	The former Yugoslav Republic of Macedonia	TM	Turkmenistan
BF	Burkina Faso	GR	Greece			TR	Turkey
BG	Bulgaria	HU	Hungary	ML	Mali	TT	Trinidad and Tobago
BJ	Benin	IE	Ireland	MN	Mongolia	UA	Ukraine
BR	Brazil	IL	Israel	MR	Mauritania	UG	Uganda
BY	Belarus	IS	Iceland	MW	Malawi	US	United States of America
CA	Canada	IT	Italy	MX	Mexico	UZ	Uzbekistan
CF	Central African Republic	JP	Japan	NE	Niger	VN	Viet Nam
CG	Congo	KE	Kenya	NL	Netherlands	YU	Yugoslavia
CH	Switzerland	KG	Kyrgyzstan	NO	Norway	ZW	Zimbabwe
CI	Côte d'Ivoire	KP	Democratic People's Republic of Korea	NZ	New Zealand		
CM	Cameroon			PL	Poland		
CN	China	KR	Republic of Korea	PT	Portugal		
CU	Cuba	KZ	Kazakstan	RO	Romania		
CZ	Czech Republic	LC	Saint Lucia	RU	Russian Federation		
DE	Germany	LI	Liechtenstein	SD	Sudan		
DK	Denmark	LK	Sri Lanka	SE	Sweden		
EE	Estonia	LR	Liberia	SG	Singapore		

INHALATION DEVICE

The present invention relates to a powder inhaler and a method of constructing the same.

5 A number of powder inhalers are known which use different systems for introducing a dose of powder into an air stream. Typically, the powder is inhaled into the lungs of a patient in order to treat, for example, asthma.

One such powder inhaler is disclosed in EP-A-0237507. This inhaler comprises an
10 inhalation channel and a mouthpiece comprising an air chamber and an outlet nozzle, which together define a flow path through which a stream of air is drawn during inhalation by a user. This inhaler further comprises means for introducing powder into the inhalation channel. During inhalation, air is first drawn into and through the inhalation channel so as to pick up powder. The stream of air containing powder is then drawn through the air
15 chamber and out of the outlet nozzle of the mouthpiece.

Powder inhalers are, however, particularly susceptible to the effects of moisture. In order to alleviate problems associated with moisture uptake it has been proposed to include a desiccant, such as silica gel, in the inhaler to absorb any moisture. It has also been
20 proposed to provide the inhaler with a cap which is either screwed or pressed onto the inhaler body so as to close any flow paths between the stored powder and atmosphere.

In powder inhalers of the kind which comprise an inhaler body and a grip portion at one end thereof, which grip portion is rotatable relative to the inhaler body so as to provide a
25 dose of powder for inhalation, it has been proposed to provide a chamber in the grip portion for containing desiccant and to provide a cap which covers substantially all of the inhaler body and is screwed onto the grip portion so as to seal therewith and thereby exclude moisture from the inhaler body in which the powder is stored.

Figures 1 to 3 illustrate such a powder inhaler. The inhaler comprises a mouthpiece 2 comprising an outlet nozzle 4, an inhaler body 6 and a rotatable grip portion 8 for operating a dosing mechanism for providing doses of powder for inhalation. The inhaler body 6 is provided with an opening 10 which is filled with a window 12 through which an indicating wheel (not illustrated) is visible so as to provide an indication as to the usage of the inhaler. The inhaler further comprises a cap 14 comprising a tubular section having a closed end which is configured to fit over the mouthpiece 2 and the inhaler body 6. The cap 14 includes a sealing surface 15 at the inner peripheral edge of the lip 16 at the open end thereof, which sealing surface 15 tapers outwardly in the direction from the closed to the open end of the cap 14. The cap 14 further includes screw threads 17 provided to the inner surface thereof.

The grip portion 8 comprises first and second hollow parts 18, 20 which are mutually configured so as to define an enclosed chamber 22 for containing desiccant when fitted together.

The first part 18 comprises a tubular section 24, in this inhaler of generally cylindrical cross-section, having a circumferential ridge 26 disposed about the outer surface of one, the upper, end thereof to which the inhaler body 6 is clipped and screw threads 28 to which the cap 14 having corresponding screw threads 17 is screwed so as to cover the mouthpiece 2 and the inhaler body 6 and thus form a tight seal. The first part 18 further comprises an upwardly-directed resiliently-biased arm 30 disposed at the periphery of the upper end thereof, which arm 30, on rotation of the grip portion 8, engages part of the dosing mechanism so as to provide a dose of powder for inhalation. The first part 18 yet further comprises a transverse wall 32 which is permeable to moisture. The wall 32 is preferably formed at least in part of cardboard.

The second part 20 comprises a tubular section 34, in this inhaler of generally cylindrical cross-section, one, the lower, end of which is closed by a wall 36. The outer surface of the tubular section 34 includes a plurality of axially-directed ridges 38 which are gripped by a

user on rotation of the grip portion 8 and a sealing surface 40 at the outer peripheral edge of the lip 41 at the open end thereof, which sealing surface 40 tapers inwardly in the direction from the closed to the open end of the second part 20. In another inhaler the axially-directed ridges 38 could be replaced by a knurled surface. In this inhaler the inner
5 dimension of the tubular section 34 is configured so as to be a close radial fit over the tubular section 24 of the first part 18.

In use, the cap 14 is first removed by unscrewing in one sense, in this inhaler in the counter-clockwise sense when viewed from above. The grip portion 8 is then rotated in
10 one sense, in this inhaler also in the counter-clockwise sense when viewed from above, through a predetermined angle relative to the inhaler body 6 and back in the opposite, clockwise, sense to the original position. This action operates the dosing mechanism to provide a dose of powder for inhalation. The user then takes the mouthpiece 2 in the lips and inhales so as to draw powder into the lungs. After use, the cap 14 is then replaced by
15 screwing on in the other, clockwise, sense when viewed from above. In screwing on the cap 14 the sealing surface 15 on the cap 14 is brought into engagement with the sealing surface 40 on the grip portion 8, with a tight seal being achieved by screwing the cap 14 tightly to the grip portion 8.

20 Whilst acceptable, there are a number of drawbacks associated with this sealing arrangement. Firstly, if the cap 14 is not screwed onto the grip portion 8 tightly enough, a proper seal will not be made and there will be a risk that the cap 14 will work loose and fall off. Conversely, if the cap 14 is screwed too tightly onto the grip portion 8, a user may find the cap 14 difficult to remove. Indeed, where the cap 14 is screwed too tightly onto the
25 grip portion 8, it is possible that the lip 16 on the cap 14 or even the lip 41 on the grip portion 8 may be damaged. This is particularly the case where the inhaler is assembled by machine as it is likely that the machine may overtighten the cap 14.

It is thus an aim of the present invention to provide an inhaler in which the seal with the
30 cap is achieved without the cap having to be screwed overly tightly.

Accordingly, the present invention provides an inhaler for administering powder by inhalation, comprising: a housing having a screw thread and a substantially circular sealing surface coaxial therewith; a mouthpiece attached to the housing; and a cap for covering at least the mouthpiece, the cap having a screw thread for engaging the screw thread on the housing and a substantially circular sealing surface for engaging the sealing surface on the housing; wherein the sealing surfaces are shaped and dimensioned such that the radial force therebetween is substantially constant for any relative position where the sealing surfaces engage one another.

Preferably, the sealing surface on the housing comprises a substantially cylindrical outwardly-facing surface.

Preferably, the sealing surface on the cap comprises a substantially cylindrical inwardly-facing surface.

Preferably, the sealing surface on the housing is provided by a circular lip.

Preferably, the sealing surface on the cap is provided by a circular lip.

More preferably, the forward end in the direction of fitting of at least one of the lip defining the sealing surface on the housing and the lip defining the sealing surface on the cap is shaped so as to guide the sealing surface on the cap onto the sealing surface on the housing.

In one embodiment the respective forward end is rounded.

In another embodiment the respective forward end is tapered.

Preferably, at least one of the lip defining the sealing surface on the housing and the lip defining the sealing surface on the cap is resiliently displaceable.

More preferably, at least one of the lip defining the sealing surface on the housing and the lip defining the sealing surface on the cap is formed of a resilient material.

- 5 Still more preferably, in the relaxed state, the internal diameter of the lip defining the sealing surface on the cap is smaller than the external diameter of the lip defining the sealing surface on the housing.

10 Preferably, the screw thread on the housing is disposed axially between that part to which the mouthpiece is attached and the sealing surface provided thereon.

Preferably, at least one of the sealing surface on the housing and the sealing surface on the cap is a roughened surface.

- 15 More preferably, the respective sealing surface has a matt surface finish.

Preferably, the housing and the cap are both substantially cylindrical and the sealing surface on the housing is disposed opposite the end thereof to which the mouthpiece is attached.

20

More preferably, the housing comprises a rotatable grip portion which in use is rotated to provide a dose of powder for inhalation and the sealing surface and the screw thread are provided thereon.

- 25 Still more preferably, the outer surface of the grip portion has a knurled or ridged surface which can be gripped by a user.

Preferably, the grip portion includes a chamber for containing desiccant and at least a part of the grip portion defining the chamber which is adjacent the inhaler body is permeable to
30 moisture.

The present invention also provides a method of constructing an inhaler for administering powder by inhalation which comprises a housing having a screw thread and a substantially circular sealing surface coaxial therewith, a mouthpiece attached to the housing and a cap for covering at least the mouthpiece, the cap having a screw thread for engaging the screw thread on the housing and a substantially circular sealing surface for engaging the sealing surface on the housing, the method comprising the step of shaping and dimensioning the sealing surfaces such that the radial force therebetween is substantially constant for any relative position where the sealing surfaces engage one another.

Thus, by virtue of the construction of the inhaler of the present invention the frictional resistance to rotation of the cap is substantially constant irrespective of how fully the cap is screwed onto the housing. In addition, a tight seal is achieved irrespective of the area of contact between the sealing surfaces. In a preferred embodiment the sealing surfaces are configured such that the force required to screw the cap onto the housing is sufficiently high as to prevent the cap from working loose and falling off, but sufficiently low as to enable a user to screw and unscrew the cap with relative ease.

A preferred embodiment of the present invention will now be described hereinbelow by way of example only with reference to the accompanying drawings, in which:

Figure 1 illustrates a perspective view of a powder inhaler;

Figure 2 illustrates the grip portion of the inhaler of Figure 1;

Figure 3 illustrates a fragmentary vertical sectional view of the inhaler of Figure 1; and

Figure 4 illustrates a fragmentary vertical sectional view of a powder inhaler in accordance with a preferred embodiment of the present invention.

Structurally, the powder inhaler in accordance with the preferred embodiment of the present invention is quite similar to the above-described powder inhaler. For this reason, and in order to avoid unnecessary duplication of description, only the structural differences will be described in detail and reference is made to the preceding description.

5

This inhaler differs from the above-described powder inhaler principally in that the sealing surface 15 on the cap 14 and the sealing surface 40 on the grip portion 8 comprise axially-extending cylindrical surfaces. In this embodiment the sealing surface 15 on the cap 14 is provided by the inner surface of the circumferential lip 16 at the open end thereof and the
10 sealing surface 40 on the grip portion 8 is provided by the outer surface of the circumferential lip 41 at the open end of the tubular section 34 of the second part 20. With this arrangement, when the cap 14 is screwed onto the grip portion 8, the inwardly-facing sealing surface 15 on the cap 14 engages and seals with the outwardly-facing sealing surface 40 on the grip portion 8. Since both the sealing surface 15 on the cap 14 and the
15 sealing surface 40 on the grip portion 8 are substantially co-axial, when at rest, the force acting therebetween is principally a radial force. Thus, as the cap 14 is screwed onto the grip portion 8, essentially the only resistance that will have to be overcome is that due to friction. It will of course be appreciated that as the area of contact between the sealing surface 15 on the cap 14 and the sealing surface 40 on the grip portion 8 increases, then so
20 will the frictional resistance to rotation. This increase in resistance is, however, relatively insignificant, certainly when compared to the level of resistance encountered in the first-described powder inhaler where the axial force increases significantly as the cap 14 is screwed further onto the grip portion 8.

25 In this embodiment the outer peripheral edge 41a of the lip 41 defining the sealing surface 40 on the grip portion 8 is rounded and the inner peripheral edge 16a of the lip 16 defining the sealing surface 15 on the cap 14 is tapered outwardly in the direction from the closed to the open end thereof. By so shaping the lip 41 on the grip portion 8 and the lip 16 on the cap 14, the sealing surface 15 defined by the lip 16 is guided onto the sealing surface 40
30 defined by the lip 41. It will of course be appreciated that the outer peripheral edge 41a of

the lip 41 on the grip portion 8 could alternatively be tapered inwardly in the direction from the closed to the open end of the second part 20 thereof and the inner peripheral edge 16a of the lip 16 on the cap 14 could alternatively be rounded. Indeed, the outer peripheral edge 41a of the lip 41 on the grip portion 8 and the inner peripheral edge 16a of the lip 16 on the cap 14 could have any shape which assists in guiding the sealing surface 15 defined by the lip 16 onto the sealing surface 40 defined by the lip 41.

In a preferred embodiment one or both of the lip 16 defining the sealing surface 15 on the cap 14 and the lip 41 defining the sealing surface 40 on the grip portion 8 are formed from a resilient material. In another embodiment one or both of the lip 16 defining the sealing surface 15 on the cap 14 and the lip 41 defining the sealing surface 40 on the grip portion 8 can be formed of a sufficiently small thickness as to be resiliently displacable. With these arrangements, the internal diameter of the sealing surface 15 defined by the lip 16 on the cap 14 can be smaller than the external diameter of the sealing surface 40 defined by the lip 41 on the grip portion 8; these diameters being those when the sealing surfaces 15, 40 are not acted upon and hence in the non-displaced, relaxed or natural state. Thus, with the cap 14 screwed onto the grip portion 8, one or both of the lip 16 defining the sealing surface 15 on the cap 14 and the lip 41 defining the sealing surface 40 on the grip portion 8 are displaced from the relaxed state so as to provide an increased radial force. In this embodiment the increased radial force will contribute to the frictional force which resists loosening of the cap 14.

In this embodiment, as illustrated in Figure 4, the lip 41 on the second part 20 of the grip portion 8 defining the sealing surface 40 is unsupported from behind. Thus, if formed from a resilient or flexible material, the lip 41 on the grip portion 8 can be deflected radially inwardly. In this way, when the cap 14 is screwed onto the grip portion 8, the lip 41 on the grip portion 8 is deflected and acts to provide a sealing force. This sealing force is relatively constant throughout the travel of the cap 14 in being screwed onto the grip portion 8. This can be contrasted to the arrangement of the first-described powder inhaler where the lip 41 defining the sealing surface 40 on the grip portion 8 is supported and

immovable. The first-described powder inhaler relies on compression of the respective lips 16, 41 on the grip portion 8 and the cap 14, neither of which can be made from a particularly resilient material. Thus, in that powder inhaler the resistance to screwing on the cap 14 will increase dramatically as the cap 14 is screwed onto the grip portion 8.

5

Where the lip 41 defining the sealing surface 40 on the grip portion 8 is formed from a flexible plastics material, typically by moulding, the cap 14 can tend to stick to the sealing surface 40. In a preferred embodiment, in order to alleviate this problem, the sealing surface 40 can be formed with or treated to have a slightly roughened finish. It will of course be appreciated that the sealing surface 40 should not be too rough, since a very rough surface would increase the resistance to screwing on the cap 14. In a preferred embodiment the sealing surface 40 has a matt finish.

Finally, it will be understood by a person skilled in the art that the present invention has been described in its preferred embodiment and can be modified in many different ways without departing from the scope of the invention as defined in the appended claims. For example, one possible modification is to seat an annular ring formed of resilient material, typically rubber, in one of the sealing surfaces 15, 40 such that the annular ring will transmit only a radial force therebetween.

15

CLAIMS

1. A powder inhaler for administering powder by inhalation, comprising:
a housing having a screw thread (28) and a substantially circular sealing surface (40)
5 coaxial therewith;
a mouthpiece (2) attached to the housing; and
a cap (14) for covering at least the mouthpiece (2), the cap (14) having a screw thread (17)
for engaging the screw thread (28) on the housing and a substantially circular sealing
surface (15) for engaging the sealing surface (40) on the housing;
10 wherein the sealing surfaces (15, 40) are shaped and dimensioned such that the radial
force therebetween is substantially constant for any relative position where the sealing
surfaces (15, 40) engage one another.
2. The inhaler according to claim 1, wherein the sealing surface (40) on the housing
15 comprises a substantially cylindrical outwardly-facing surface.
3. The inhaler according to claim 1 or 2, wherein the sealing surface (15) on the cap (14)
comprises a substantially cylindrical inwardly-facing surface.
- 20 4. The inhaler according to any of claims 1 to 3, wherein the sealing surface (40) on the
housing is provided by a circular lip (41).
5. The inhaler according to any of claims 1 to 4, wherein the sealing surface (15) on the
cap (14) is provided by a circular lip (16).
25
6. The inhaler according to claim 4 or 5, wherein the forward end in the direction of fitting
of at least one of the lip (41) defining the sealing surface (40) on the housing and the lip
(16) defining the sealing surface (15) on the cap (14) is shaped so as to guide the sealing
surface (15) on the cap (14) onto the sealing surface (40) on the housing.
30

7. The inhaler according to claim 6, wherein the respective forward end is rounded.
8. The inhaler according to claim 6, wherein the respective forward end is tapered.
- 5 9. The inhaler according to any of claims 4 to 8, wherein at least one of the lip (41) defining the sealing surface (40) on the housing and the lip (16) defining the sealing surface (15) on the cap (14) is resiliently displaceable.
- 10 10. The inhaler according to any of claims 4 to 9, wherein at least one of the lip (41) defining the sealing surface (40) on the housing and the lip (41) defining the sealing surface (15) on the cap (14) is formed of a resilient material.
- 15 11. The inhaler according to claim 9 or 10, wherein, in the relaxed state, the internal diameter of the lip (16) defining the sealing surface (15) on the cap (14) is smaller than the external diameter of the lip (41) defining the sealing surface (40) on the housing.
- 20 12. The inhaler according to any of claims 1 to 11, wherein the screw thread (28) on the housing is disposed axially between that part to which the mouthpiece (2) is attached and the sealing surface (40) provided thereon.
- 25 13. The inhaler according to any of claims 1 to 12, wherein at least one of the sealing surface (40) on the housing and the sealing surface (15) on the cap (14) is a roughened surface.
- 30 14. The inhaler according to claim 13, wherein the respective sealing surface (15, 40) has a matt surface finish.
15. The inhaler according to any of claims 1 to 14, wherein the housing and the cap (14) are both substantially cylindrical and the sealing surface (40) on the housing is disposed opposite the end thereof to which the mouthpiece (2) is attached.

16. The inhaler according to claim 15, wherein the housing comprises a rotatable grip portion (8) which in use is rotated to provide a dose of powder for inhalation and the sealing surface (40) and the screw thread (28) are provided thereon.

5

17. The inhaler according to claim 16, wherein the outer surface of the grip portion (8) has a knurled or ridged surface (38) which can be gripped by a user.

18. The inhaler according to claim 16 or 17, wherein the grip portion (8) includes a chamber (22) for containing desiccant and at least a part of the grip portion (8) defining the chamber (22) which is adjacent the inhaler body (6) is permeable to moisture.

10

19. A method of constructing an inhaler for administering powder by inhalation which comprises a housing having a screw thread (28) and a substantially circular sealing surface (40) coaxial therewith, a mouthpiece (2) attached to the housing and a cap (14) for covering at least the mouthpiece (2), the cap (14) having a screw thread (17) for engaging the screw thread (28) on the housing and a substantially circular sealing surface (15) for engaging the sealing surface (40) on the housing, the method comprising the step of shaping and dimensioning the sealing surfaces (15, 40) such that the radial force therebetween is substantially constant for any relative position where the sealing surfaces (15, 40) engage one another.

15

20

1/4

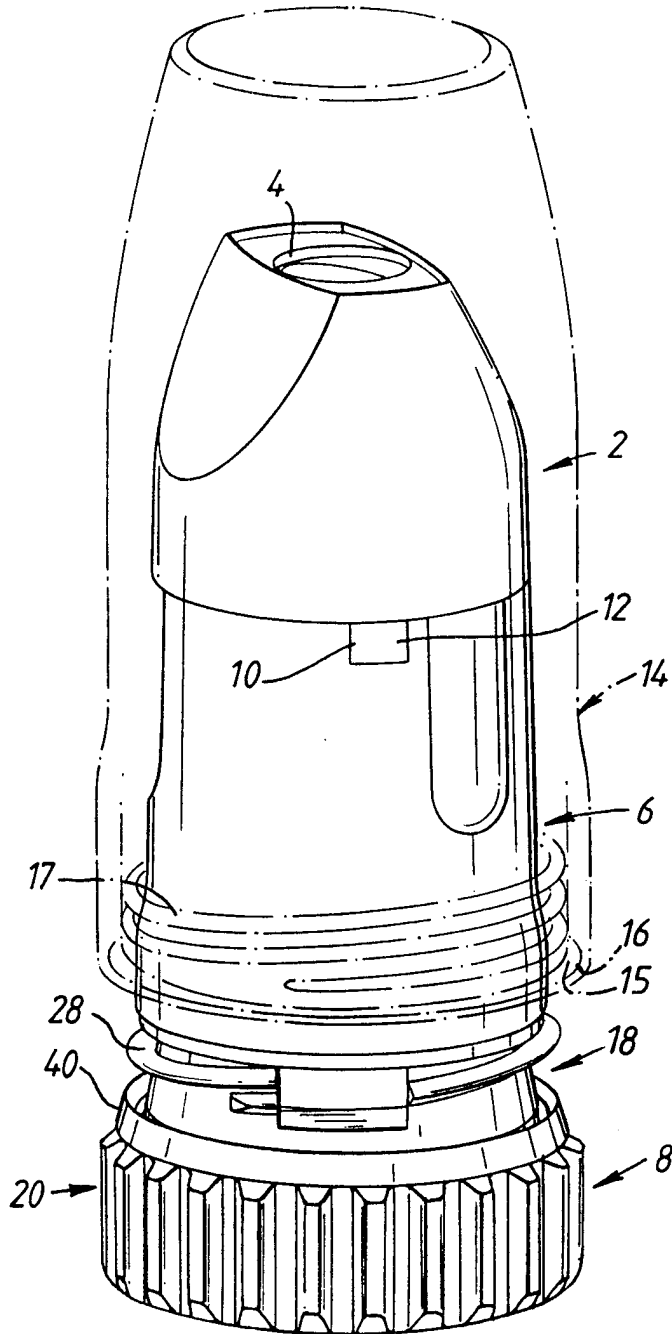

Fig.1

2/4

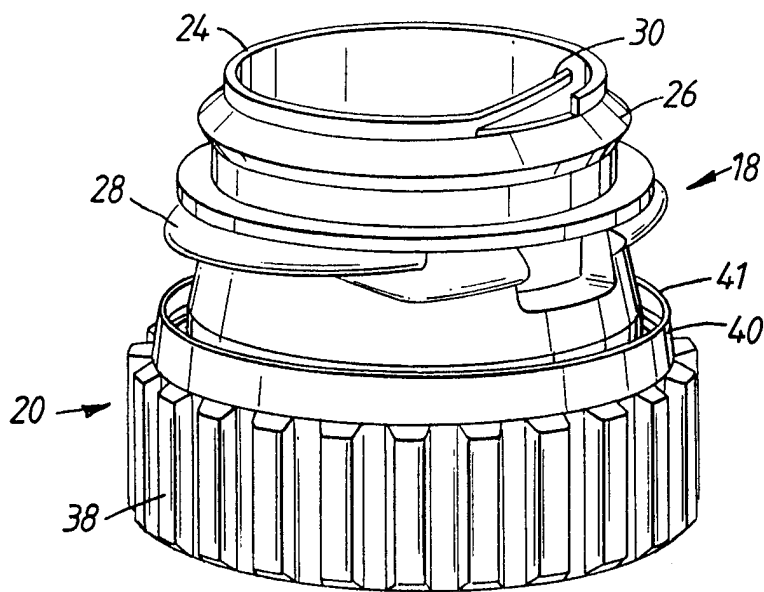

Fig.2

3/4

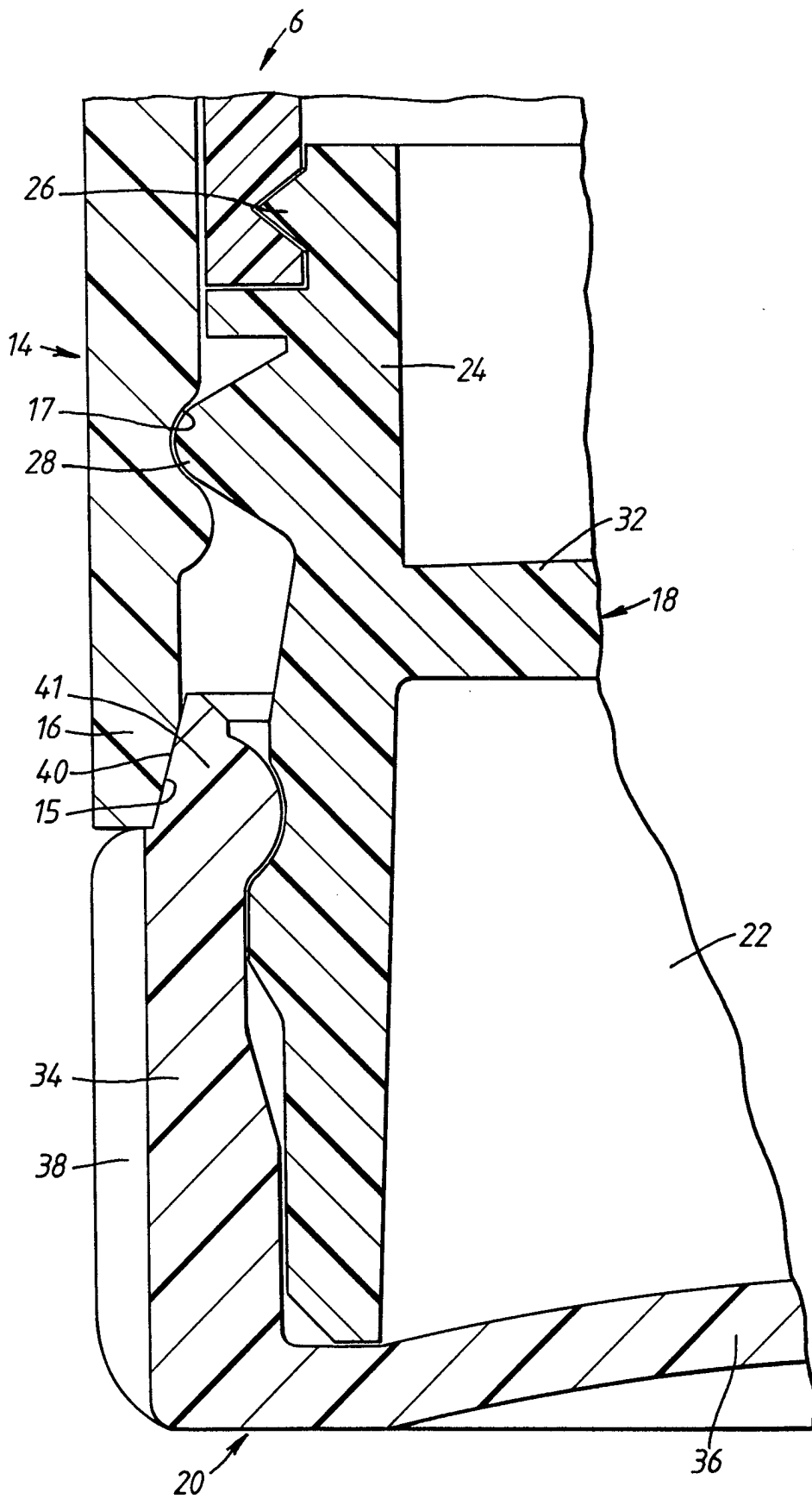

Fig. 3

4/4

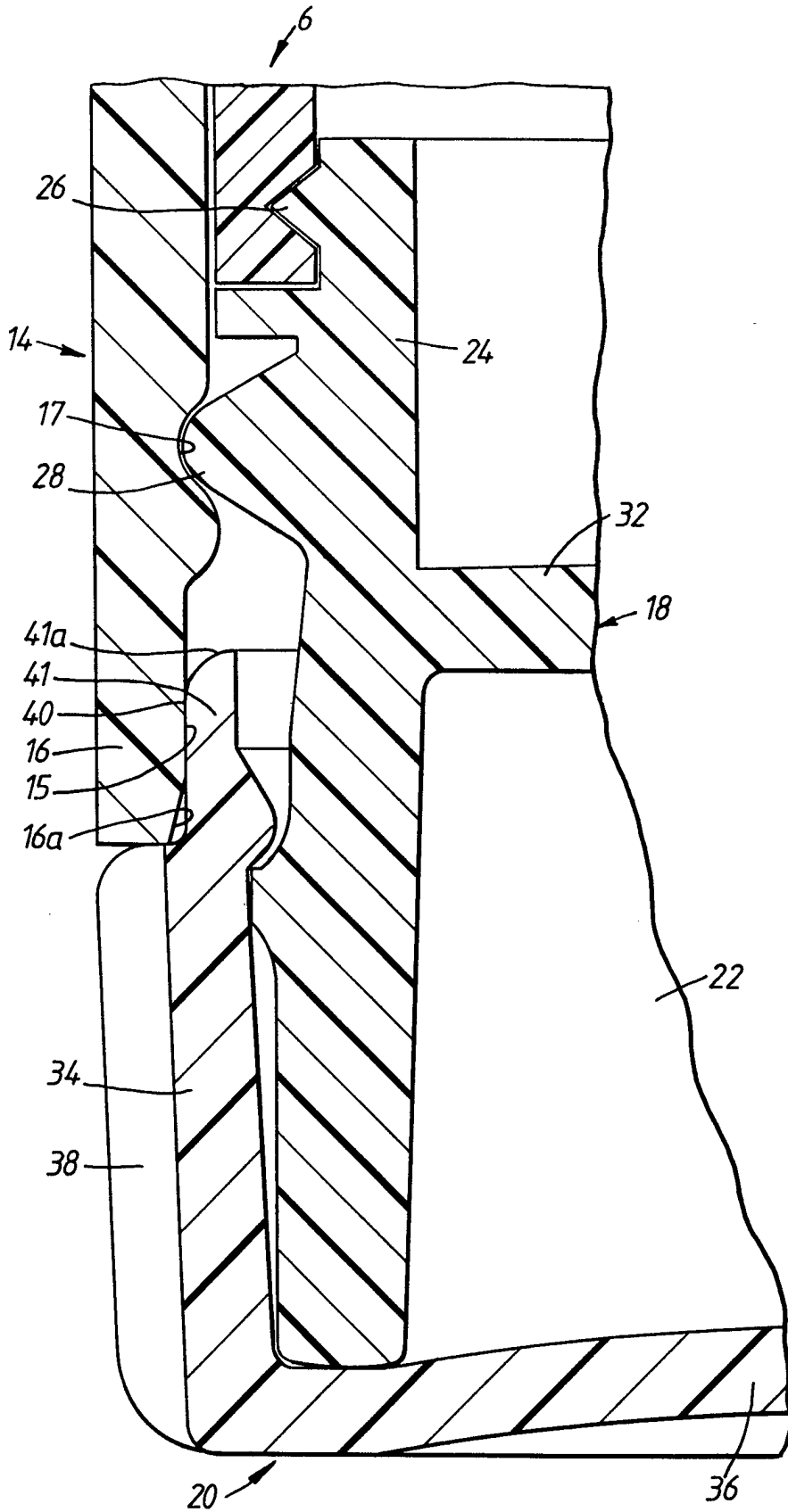

Fig. 4

INTERNATIONAL SEARCH REPORT

International Application No

PCT/SE 98/00463

A. CLASSIFICATION OF SUBJECT MATTER
 IPC 6 A61M15/00 B65D41/04

According to International Patent Classification (IPC) or to both national classification and IPC

B. FIELDS SEARCHED

Minimum documentation searched (classification system followed by classification symbols)
 IPC 6 A61M B65D

Documentation searched other than minimum documentation to the extent that such documents are included in the fields searched

Electronic data base consulted during the international search (name of data base and, where practical, search terms used)

C. DOCUMENTS CONSIDERED TO BE RELEVANT

Category	Citation of document, with indication, where appropriate, of the relevant passages	Relevant to claim No.
X	DE 44 15 462 C (TRANSCOJECT MARKETING GMBH) 31 August 1995 see column 6, line 4 - line 31; figures 1,5 ---	1,5-7, 16,18,19
A	EP 0 451 745 A (CHIESI FARMA SPA) 16 October 1991 see page 4, line 9 - line 16; figure 1 ---	1,19
A	WO 95 15892 A (DENTAL KOSMETIK GMBH ;RINNE ROLF (DE)) 15 June 1995 see abstract; figures ---	1,19
A	US 5 009 323 A (MONTGOMERY GARY V ET AL) 23 April 1991 -----	

Further documents are listed in the continuation of box C.

Patent family members are listed in annex.

Special categories of cited documents :

- "A" document defining the general state of the art which is not considered to be of particular relevance
- "E" earlier document but published on or after the international filing date
- "L" document which may throw doubts on priority claim(s) or which is cited to establish the publication date of another citation or other special reason (as specified)
- "O" document referring to an oral disclosure, use, exhibition or other means
- "P" document published prior to the international filing date but later than the priority date claimed

- "T" later document published after the international filing date or priority date and not in conflict with the application but cited to understand the principle or theory underlying the invention
- "X" document of particular relevance; the claimed invention cannot be considered novel or cannot be considered to involve an inventive step when the document is taken alone
- "Y" document of particular relevance; the claimed invention cannot be considered to involve an inventive step when the document is combined with one or more other such documents, such combination being obvious to a person skilled in the art.
- "&" document member of the same patent family

Date of the actual completion of the international search

11 June 1998

Date of mailing of the international search report

24/06/1998

Name and mailing address of the ISA

European Patent Office, P.B. 5818 Patentlaan 2
 NL - 2280 HV Rijswijk
 Tel. (+31-70) 340-2040, Tx. 31 651 epo nl,
 Fax: (+31-70) 340-3016

Authorized officer

Villeneuve, J-M

INTERNATIONAL SEARCH REPORT

Information on patent family members

International Application No

PCT/SE 98/00463

Patent document cited in search report	Publication date	Patent family member(s)	Publication date
DE 4415462 C	31-08-1995	AU 2523795 A	29-11-1995
		WO 9529723 A	09-11-1995
EP 0451745 A	16-10-1991	IT 1240750 B	17-12-1993
		AT 108676 T	15-08-1994
		AU 640764 B	02-09-1993
		AU 7432491 A	17-10-1991
		CA 2040269 A	13-10-1991
		DE 69102928 D	25-08-1994
		DE 69102928 T	03-11-1994
		DK 451745 T	14-11-1994
		EG 19770 A	31-01-1996
		ES 2026835 T	01-11-1994
		FI 911738 A	13-10-1991
		HU 209475 B	28-06-1994
		IE 66035 B	29-11-1995
		JP 4227269 A	17-08-1992
		NO 300760 B	21-07-1997
		NZ 237763 A	25-03-1994
		PT 97326 A	31-01-1992
US 5351683 A	04-10-1994		
WO 9515892 A	15-06-1995	DE 4342251 C	11-05-1995
		AT 156084 T	15-08-1997
		EP 0733013 A	25-09-1996
		ES 2105778 T	16-10-1997
		JP 9501131 T	04-02-1997
		US 5722545 A	03-03-1998
US 5009323 A	23-04-1991	CA 2014709 A	13-05-1991