

(19) World Intellectual Property Organization  
International Bureau



(43) International Publication Date  
18 June 2009 (18.06.2009)

PCT

(10) International Publication Number  
**WO 2009/076635 A2**

- (51) International Patent Classification:  
*E21B 1/22* (2006.01)
- (21) International Application Number:  
PCT/US2008/086679
- (22) International Filing Date:  
12 December 2008 (12.12.2008)
- (25) Filing Language: English
- (26) Publication Language: English
- (30) Priority Data:  
61/012,941 12 December 2007 (12.12.2007) US
- (71) Applicant (for CA only): **SCHLUMBERGER CANADA LIMITED** [CA/CA]; 525-3rd Avenue Southwest, Calgary, T2P 0G4 (CA).
- (71) Applicant (for FR only): **SERVICES PETROLIERS SCHLUMBERGER** [FR/FR]; 42 Rue Saint Dominique, F-75007 Paris (FR).

- (71) Applicant (for GB, JP, NL only): **SCHLUMBERGER HOLDINGS LIMITED** [NL/—]; P.o. Box 71, Craigmuir Chambers, Road Town, Tortola (VG).
- (71) Applicant (for AL, AM, AU, AZ, BF, BG, BJ, BY, CF, CG, CI, CM, CO, CZ, DE, DK, GA, GN, GQ, GR, GW, HU, ID, IE, IL, IT, KG, KP, KR, KZ, LT, MD, ML, MR, MX, MY, NE, NO, NZ, OM, PL, RO, RU, SI, SK, SN, TD, TG, TJ, TM, TN, TR, TT, UZ, ZA only): **SCHLUMBERGER TECHNOLOGY B.V.** [NL/NL]; Parkstraat 83-89 2514 Jg, The Hague (NL).
- (71) Applicant (for all designated States except AL, AM, AU, AZ, BF, BG, BJ, BY, CA, CF, CG, CI, CM, CO, CZ, DE, DK, FR, GA, GB, GN, GQ, GR, GW, HU, ID, IE, IL, IT, JP, KG, KP, KR, KZ, LT, MD, ML, MR, MX, MY, NE, NL, NO, NZ, OM, PL, RO, RU, SI, SK, SN, ST, TD, TG, TJ, TM, TN, TR, TT, US, UZ, ZA): **PRAD RESEARCH AND DEVELOPMENT LIMITED**; Craigmuir Chambers, Road Town, Tortola (VG).
- (72) Inventors; and
- (75) Inventors/Applicants (for US only): **LOPEZ DE CARDENAS, Jorge, E.** [MX/US]; 22 Grassy Knolls, Sugar

[Continued on next page]

(54) Title: DEVICE AND METHOD TO REDUCE BREAKDOWN/FRACTURE INITIATION PRESSURE

Figure 1

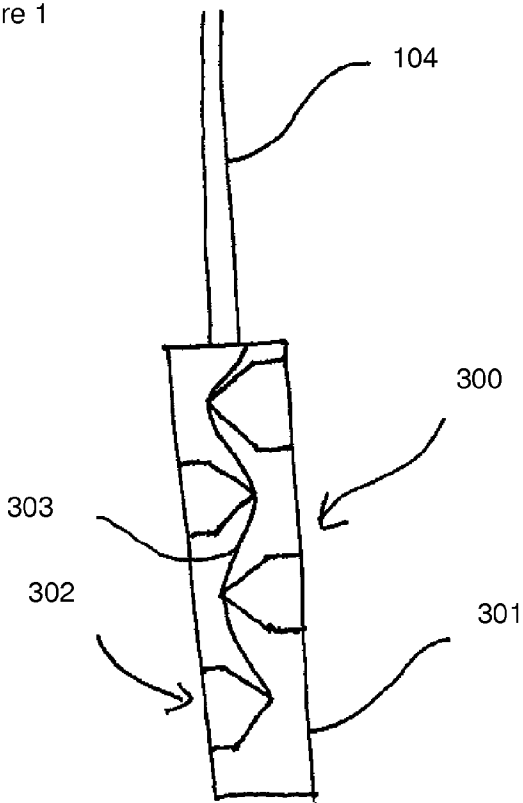

(57) Abstract: A slim perforating gun includes a plurality of shape charges; a positioning device that orients the perforating gun in relation to a down direction of a deviated well; the shaped charges being positioned inside the perforating gun and aimed in predetermined directions with respect to the down direction of the deviated well; wherein a ratio of the outer diameter of the slim perforating gun to the inner diameter of a casing used in connection with the slim perforating gun is from .85 to .30.

WO 2009/076635 A2



Land, TX 77479 (US). **SWAREN, Jason** [CA/US]; 231 Needleleaf Lane, Sugar Land, TX 77479 (US). **REES, Desmond, E.** [US/US]; 4720 Picadilly Place, Tyler, TX 75703 (US). **CAMPBELL, Jerry, D.** [US/US]; 714 Red Rock Canyon Road, Katy, TX 77450 (US).

(74) **Agent: MCGOFF, Kevin, B.**; Schlumberger Technology Corporation, 14910 Airline Road, Legal - IP Building 20, Rosharon, TX 77583 (US).

(81) **Designated States** (*unless otherwise indicated, for every kind of national protection available*): AE, AG, AL, AM, AO, AT, AU, AZ, BA, BB, BG, BH, BR, BW, BY, BZ, CA, CH, CN, CO, CR, CU, CZ, DE, DK, DM, DO, DZ, EC, EE, EG, ES, FI, GB, GD, GE, GH, GM, GT, HN, HR, HU, ID, IL, IN, IS, JP, KE, KG, KM, KN, KP, KR, KZ, LA, LC, LK, LR, LS, LT, LU, LY, MA, MD, ME, MG, MK, MN, MW,

MX, MY, MZ, NA, NG, NI, NO, NZ, OM, PG, PH, PL, PT, RO, RS, RU, SC, SD, SE, SG, SK, SL, SM, ST, SV, SY, TJ, TM, TN, TR, TT, TZ, UA, UG, US, UZ, VC, VN, ZA, ZM, ZW.

(84) **Designated States** (*unless otherwise indicated, for every kind of regional protection available*): ARIPO (BW, GH, GM, KE, LS, MW, MZ, NA, SD, SL, SZ, TZ, UG, ZM, ZW), Eurasian (AM, AZ, BY, KG, KZ, MD, RU, TJ, TM), European (AT, BE, BG, CH, CY, CZ, DE, DK, EE, ES, FI, FR, GB, GR, HR, HU, IE, IS, IT, LT, LU, LV, MC, MT, NL, NO, PL, PT, RO, SE, SI, SK, TR), OAPI (BF, BJ, CF, CG, CI, CM, GA, GN, GQ, GW, ML, MR, NE, SN, TD, TG).

**Published:**

— *without international search report and to be republished upon receipt of that report*

## DEVICE AND METHOD TO REDUCE BREAKDOWN/FRACTURE INITIATION PRESSURE

### RELATED APPLICATION

This present application claims the benefit of the filing date of U.S. Provisional Patent Application No. 61/012,941, filed December 12, 2007 incorporated herein by reference in its entirety.

### TECHNICAL FIELD

The present application relates to perforating, and more particularly, orienting a direction of perforating charges for a slim perforating gun in a deviated well.

### BACKGROUND

Subterranean fluids are desirable for extraction. These fluids are often water, oil, or natural gas. Alternatively, it is often desired to inject fluids and gases into subterranean regions for various reasons that are known in the art.

To access subterranean regions, wells are created. Generally, in the hydrocarbon industry, wells are drilled from surface into formation. Those wells are cased with a metal casing. In order to access the formation surrounding the casing from within the casing in order to retrieve formation fluids (oil/water/natural gas), perforations are creating through the casing.

The perforations are generally created with a perforating gun that uses charges to fire matter through the casing and into the formation to further assist in the flow of formation fluids into the casing annulus.

In connection with that activity, many issues arise. Some of those issues are described and addressed in the present application.

## SUMMARY

According to one of the embodiments, a slim perforating gun comprises a plurality of shape charges; a positioning device that orients the perforating gun in relation to a down direction of a deviated well; the shaped charges being positioned inside the perforating gun and aimed in predetermined directions with respect to the down direction of the deviated well; wherein a ratio of the outer diameter of the slim perforating gun to the inner diameter of a casing used in connection with the slim perforating gun is from .85 to .30.

The summary relates to at least one embodiment and is not meant in any way to limit the interpreted scope of any inventive aspects of this application or the scope of any claims recited herein.

## BRIEF DESCRIPTION OF THE DRAWINGS

Figure 1 is a schematic of a perforating gun.

Figure 2 is schematic showing a slim gun having a shot interval of 60 degrees.

Figure 3 is a schematic showing a slim gun having a shot interval of 180 degrees.

## DETAILED DESCRIPTION

In the following description, numerous details are set forth to provide an understanding of embodiments described herein. However, it will be understood by those skilled in the art that the presently claimed subject matter may be practiced without many of these details and that numerous variations or modifications from the described embodiments may be possible.

In the specification and appended claims: the terms "connect", "connection", "connected", "in connection with", and "connecting" are used to mean "in direct connection with" or "in connection with via another element"; and the term "set" is used to mean "one element" or "more than one element". As used herein, the terms "uphole", "downhole", "up" and "down", "upper" and "lower", "upwardly" and "downwardly", "upstream" and "downstream"; "above"

and "below"; and other like terms indicating relative positions above or below a given point or element are used in this description to more clearly described some embodiments of the invention. However, when applied to equipment and methods for use in wells that are deviated or horizontal, such terms may refer to a left to right, right to left, or other relationship as appropriate.

Multiple-stage fracturing relates to completion of a well and includes running in the hole with a string of multiple wireline guns that are fired one by one selectively at each stage, leaving the guns in the well while the fracture is being pumped. Diversion between zones is obtained by pumping a set of ball sealers from the surface to plug the perforations of each zone. At the time that the ball sealers plug the perforations of the zone being treated, another gun in the string is fired at the next zone to be fractured. The operation is repeated for each zone saving valuable time as compared with conventional ways of completing these type of wells (i.e., set a bridge plug, perforate, remove guns from the well, frac, move to the next zone and repeat for each zone, and at the end drill the bridge plugs). That process and accompanying equipment is readily understandable in the art and therefore excluded from the drawings herein.

According to an embodiment in the present application, since the multi-stage treatment method requires leaving the guns in the well as the fracture is being pumped, it has been found that it is beneficial to use small diameter guns (slim guns), e.g., to avoid excessive tension on the wireline cable and to allow sufficient clearance between the guns and the inside diameter of the casing.

However, use of the slim guns results in undesirable issues. For example, a slim gun tends to produce perforations of significantly different sizes. Also, due to the size of slim guns and various factors, excessive breakdown pressure has been observed in many cases.

Accordingly, the present application relates to equipment and methods for orienting slim perforating guns and charges in such a way to avoid undesired differences in size of the perforations, perforating in relation to the Preferred Fracture Plane (PFP) with regard to the direction of minimal horizontal stress in the formation, and avoiding high fracturing breakdown

pressure when a slim gun is used to perforate an interval in a well that needs to be fractured.

Figure 1 shows a schematic of a slim perforating gun 300. The perforating gun 300 is supported by a member 104, preferably a wireline, slickline, coiled tubing, or production tubing. The perforating gun 300 includes a body 301 that is normally tubular or cylindrical and made from metal. Within the body 301 are shaped charges 302 that are connected by a detonating cord 303. Shaped charges 302 have a case, a liner, explosives between the case and the liner, and a detonator. The shaped charges are activated by the detonating cord 303.

Figures 2 and 3 are schematics showing an axial view of firing of a slim perforating gun. A slim perforating gun 201 is located inside a deviated well casing 202. In Figure 2, the slim perforating gun 201 is on the lower part of the casing 202 due to gravity and deviation of the well. Cement 203 surrounds the casing 202. Formation 204 surrounds the cement 203. Figure 2 shows a configuration of the perforating gun 201 where the shaped charges are at approximately 60 degree intervals from one another. Given that spacing, the distances for the shots from the different charges are significantly different.

Figure 3 shows a schematic where like numbers correspond to like parts shown in Figure 2. In Figure 3, the angular spacing of the shaped charges is 180 degrees, and that direction is substantially parallel to the tangent of the casing that the gun 201 is most near. Accordingly, the distances of each shot to the casing are substantially equal thereby encouraging the perforations to have a same or similar size.

Some embodiments addressed in this application generally relate to a well construction method comprising drilling a slightly deviated well, anywhere from 5 to 45 degrees, but preferably around 15 degrees and close or in the direction of the minimum horizontal stress in the formation. Having the wells drilled with that deviation and azimuth allows the use of gravity to position and orient the gun with shape charges phased at 180 degree with shots in the direction of the preferred fracture plane (PFP). If the well is drilled, for example, in the direction of the minimum horizontal stress, then, as described herein, the gun can be oriented to have the perforations perpendicular to the

radius of the gun 201 in the gun to casing point of contact as shown in Figure 3. An advantage of using that method with a slim gun having 180 degree phasing is that the entrance hole (EH) on both phases tends to be very uniform and symmetrical.

Looking particularly at the slim gun 201, in the context of the present application, a slim gun 201 is a perforating gun having a maximum outer diameter that is less than a recommended API diameter for a particular casing size. According to some embodiments, a slim gun 201 can have a ratio between the maximum outer diameter of the slim gun 201 and the inside diameter of the casing 202 of about .85 to .35, and is preferably between about .8 to .4.

Some embodiments described herein generally relate to a design and use of slightly deviated wells in a predetermined direction relative to the preferential PFP with the use of oriented perforating, aided by gravity, to align the perforations with the PFP. Also, some embodiments relate to gun charge phasing and positioning devices to assure both a relatively uniform exit hole diameter in the casing and alignment of the perforations with the PFP or within or close to 30 degree phasing of the PFP.

A well construction method for the purpose of increasing the efficiency and effectiveness of a hydraulic fracture includes a design and construction of (slightly) deviated wells with a known azimuth with respect to the PFP, and the positioning of guns against the low (down) side of the casing, and orienting the perforations in relation to the azimuth of the well. A primary use of that method is to shoot a slim gun with 180 degree phasing in the direction of the PFP.

Another aspect relates to the design and use of shot phasing in slim guns 201 in such a way as to assure that the perforations are approximately within 30 degrees from the PFP, regardless of the relative orientation of the gun 201 with respect to the PFP while, for slim guns, shooting only in directions where the perforations have a small clearance between the gun and the casing, e.g. shooting with a phasing of 0, +60/-60 degree (tri-phase) in the direction of a hemisphere of the gun in contact with the casing, with a phasing of +/-90, +/- 30 degree (quad-phase), or with a phasing of 180 degrees positioned as shown in Fig. 3.

A preferred perforation pattern for hydraulic fracturing is 180 degrees in the direction of the PFP, that is, in the direction of the maximum horizontal stress as shown in Figure 3. That perforation pattern maximizes the chances of having all perforations connected to the PFP, minimizes tortuosity and reduces break down and treating pressure.

Figure 2 illustrates a 2" gun shot in 5-1/2" casing and a corresponding variation on the entrance hole size in the casing varying from 0.11" to 0.5". As alluded to earlier, the hole size variation presents two issues: 1) since the pressure drop of a liquid being pumped through a hole in the casing is given by Equation 1 (shown below) the difference in pressure drop between the largest and smallest hole could be relatively large, e.g. above 460% for the instance; and 2) the smaller holes would be too small to adequately pump proppant through them (the recommended guidelines is to have a hole size of at least 6 times the diameter of the proppant)..

Equation 1:  $P_{pf} = (2.93 * Q^2 * SG) / (EH^4 * N^2)$  (Perforation Friction Pressure)

To address some of the issues mentioned above, the present application describes using slim guns 201 with a phasing so that shots are placed in directions where the perforations would have relatively small clearance, typically less than 0.5" due to the eccentricity of the gun with respect to the inside diameter (ID) of the casing 202. Typically these directions are within the hemisphere defined by a diameter of the gun 201 perpendicular to the gun-to-casing point of contact as shown in Figure 3. Furthermore, to assure that the perforations are approximately within 30 degrees of the PFP the perforations could be within 60 degrees as illustrated in Figure 2. Typical shot phasing that meets the criteria mentioned above (gun-casing clearance of less than 0.5" and assurance of having some perforations within 30 degrees of the PFP) are 0, +/- 60 degrees as shown on Fig. 2 or +/-90, +/- 30 degrees. The desired shot phasing can be achieved with several shot arrangements for example:

For the 0, +/- 60 degree phasing shown in Figure 2:

0, 60, 0, -60, 0, 60...

or

0, 60, -60, 0, 60...

For the +/-90, +/- 30 degree phasing:

-90, -30, 30, 90, 30, -30, -90, -30....

or

-90, -30, 30, 90, -90, -30, 30, 90...

Many other similar arrangements are possible, including leaving empty shots in conventional 60 degree phased guns.

To aid creating uniform exit hole size, the perforating guns may have some standoff, typically within 0.5" or zero. Also, in some cases, combining different shape charges in different phasing can be used to aid creating a uniform exit hole size in the casing.

Alternatively, a phasing of 180 degrees positioned as shown in Figure 3 can also be used in vertical wells to increase the chances of being closer to the PFP and thus reduce breakdown pressure. The advantage of that phasing is that because of the symmetry of the shots, it encourages very uniform exit hole, regardless of the gun standoff or type of shaped charge. Uniform exit hole size is very much desired to encourage good action of the ball sealers and adequate diversion in connection with multi-stage fracturing.

Furthermore, to facilitate and provide that the shots are directed in the correct direction, embodiments described herein can use a combination of positioning devices such as weights, magnetic positioning devices (MPDs), centralizer springs, gyroscopes, mechanical caliper devices (MCDs), or fins to position the gun string with the perforations pointing in the direction of the hemisphere with less water clearance. In addition, swivel devices can be used to decouple the torque produced by the wireline cable and preventing that way the rotation of the gun string keeping it correctly positioned with the shots in the direction of the desired hemisphere.

The embodiments and examples described herein are exemplary and are not meant to limit the scope of any claims recited herein.

What is Claimed Is:

1. A slim perforating gun system, comprising:
  - a plurality of shape charges;
  - a positioning device that orients the perforating gun in relation to a down direction of a deviated well;
  - the shape charges being positioned inside the perforating gun and aimed in predetermined directions with respect to the down direction of the deviated well;
  - wherein a ratio of the outer diameter of the slim perforating gun to the inner diameter of a casing used in connection with the slim perforating gun is from .85 to .30.
  
2. The slim perforating gun of claim 1, wherein the directions of the shape charges are phased approximately 180 degrees.
  
3. The slim perforating gun of claim 1, wherein the directions of the shape charges are phased approximately at 0, +/- 60 degrees.
  
4. The slim perforating gun of claim 1, wherein the directions of the shape charges are phased approximately at +/- 90, +/- 30 degrees.
  
5. The slim perforating gun of claim 1, wherein the positioning device comprises at least one selected from the following: magnetic device, centralizer springs, mechanical caliper devices, and fins.
  
6. The slim perforating gun of claim 5, wherein the positioning device positions the perforating gun with the shape charges pointing in a direction perpendicular to a shortest path to the casing.
  
7. The slim perforating gun of claim 1, comprising a swivel to decouple torque from a cable.

8. The slim perforating gun of claim 1, wherein a ratio of the outer diameter of the slim perforating gun to the inner diameter of the casing used in connection with the slim perforating gun is from .80 to .40.

9. The slim perforating gun of claim 1, wherein a ratio of the outer diameter of the slim perforating gun to the inner diameter of the casing used in connection with the slim perforating gun is from .7 to .40.

10. The slim perforating gun of claim 1, wherein a ratio of the outer diameter of the slim perforating gun to the inner diameter of the casing used in connection with the slim perforating gun is from .6 to .4.

11. A method of perforating a subterranean hydrocarbon well, the method comprising:  
determining an azimuth for at least a portion of a deviated well;  
placing a slim perforating gun in the well and using a positioning device to locate the perforating gun proximate to a casing in the deviated well in down direction;  
positioning a plurality of shape charges in the slim perforating gun in predetermined directions with respect to the down direction;  
wherein an outer diameter of the slim perforating gun and an inner diameter of a casing used in connection with the slim perforating gun has a ratio from .85 to .30.

12. The method of claim 11, comprising positioning the shape charges so that the directions of the shape charges are phased approximately 180 degrees.

13. The method of claim 11, comprising positioning the shape charges so that the directions of the shape charges are phased approximately at 0, +/- 60 degrees.

14. The method of claim 11, comprising positioning the shape charges so that the directions of the shape charges are phased approximately at +/- 90, +/- 30 degrees.

15. The method of claim 11, wherein the positioning device comprises at least one selected from the following: magnetic device, centralizer springs, mechanical caliper devices, and fins.

16. The method of claim 15, comprising using the positioning device to position the perforating gun with the shape charges pointing in a direction perpendicular to a shortest path to the casing.

17. The method of claim 11, wherein the azimuth of the well is substantially in a direction of minimal horizontal stress.

18. The method of claim 11, wherein a ratio of the outer diameter of the slim perforating gun to the inner diameter of the casing used in connection with the slim perforating gun is from .80 to .40.

18. The method of claim 11, wherein a ratio of the outer diameter of the slim perforating gun to the inner diameter of the casing used in connection with the slim perforating gun is from .6 to .40.

20. A method for treating multiple intervals of one or more subterranean formations intersected by a cased wellbore, said method comprising:

a) using a perforating device to perforate at least one interval of said one or more subterranean formations;

b) pumping a treating fluid into the perforations created in said at least one interval by said perforating device without removing said perforating device from said wellbore;

c) deploying one or more diversion agents in said wellbore to removably block further fluid flow into said perforations; and

d) repeating at least steps a) through b) for at least one more interval of said one or more subterranean formations; wherein at some time after step a) and before removably blocking fluid flow into said perforations, said perforating device is moved to a position above said at least one interval perforated in step a);

wherein the perforating device comprises a slim perforating gun, comprising:

a plurality of shape charges;

a positioning device that orients the perforating gun in relation to a down direction of a deviated well;

the shape charges being positioned inside the perforating gun and aimed in predetermined directions with respect to the down direction of the deviated well;

wherein a ratio of the outer diameter of the slim perforating gun to the inner diameter of a casing used in connection with the slim perforating gun is from .85 to .30.

Figure 1

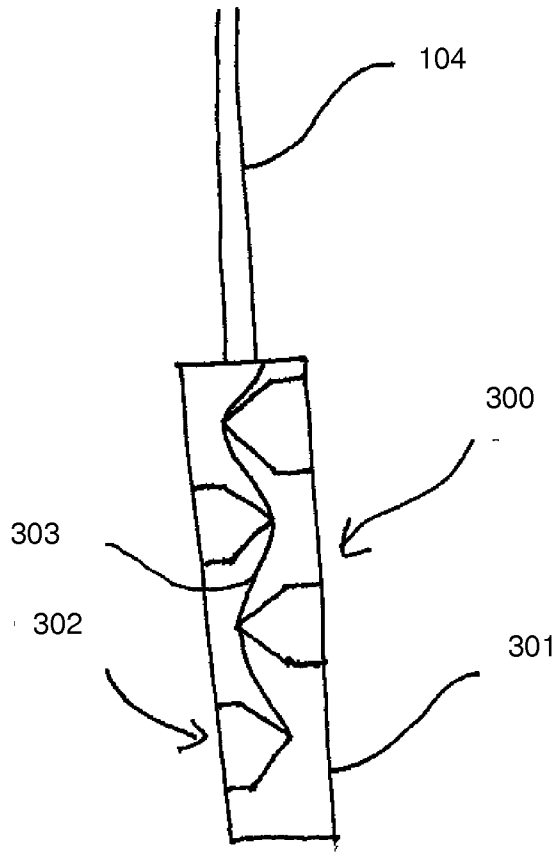

Figure 2

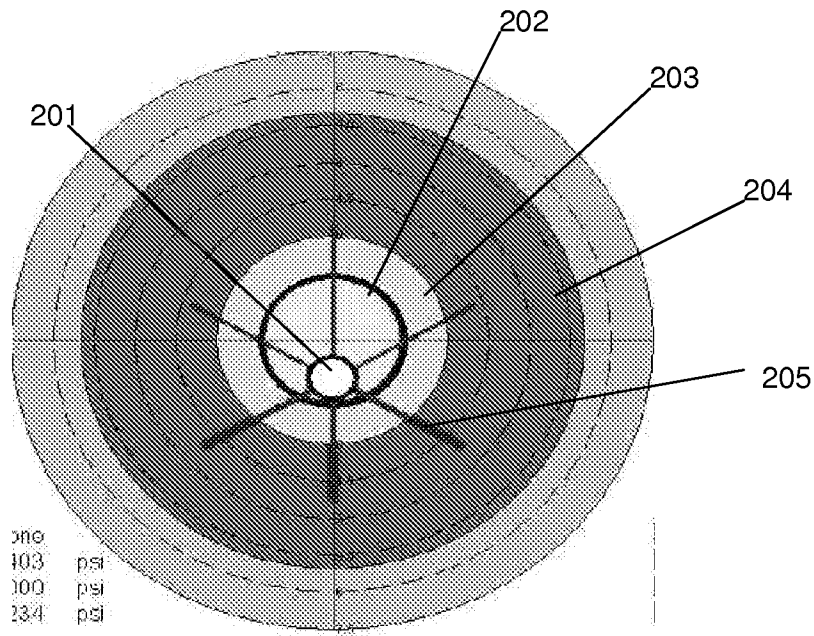

Figure 3

