



(11) **EP 1 517 043 B1**

(12) **EUROPEAN PATENT SPECIFICATION**

(45) Date of publication and mention of the grant of the patent:
26.11.2008 Bulletin 2008/48

(51) Int Cl.:
F04D 25/16^(2006.01)

(21) Application number: **04022200.2**

(22) Date of filing: **17.09.2004**

(54) **Package-type fluidic apparatus**

Strömungsgerät mit mehreren Einheiten

Appareil fluidique à plusieurs unités

(84) Designated Contracting States:
BE DE FR IT

(30) Priority: **22.09.2003 JP 2003330494**

(43) Date of publication of application:
23.03.2005 Bulletin 2005/12

(73) Proprietor: **ANEST IWATA CORPORATION**
Yokohama-shi,
Kanagawa-ken (JP)

(72) Inventors:
• **Sato, Kazuaki**
Yokoama-shi
Kanagawa (JP)
• **Fukui, Atsushi**
Yokoama-shi
Kanagawa (JP)

(74) Representative: **Trupiano, Federica**
Marietti, Gislone e Trupiano S.r.l.
Via Larga, 16
20122 Milano (IT)

(56) References cited:
FR-A- 1 078 545 **US-A- 3 242 686**

- [Online] 30 November 2001 (2001-11-30), , XP007900119 Retrieved from the Internet: URL: http://www.rogers-machinery.com/Lit/ProductBinder/02_Oil_Free_Compressors/Powerex/Powerex_SOS_Scroll_OP_SR390402.pdf [retrieved on 2006-03-06] * page 1 - page 2 *
- PATENT ABSTRACTS OF JAPAN vol. 014, no. 213 (E-0923), 7 May 1990 (1990-05-07) -& JP 02 049458 A (HITACHI LTD), 19 February 1990 (1990-02-19)

EP 1 517 043 B1

Note: Within nine months of the publication of the mention of the grant of the European patent in the European Patent Bulletin, any person may give notice to the European Patent Office of opposition to that patent, in accordance with the Implementing Regulations. Notice of opposition shall not be deemed to have been filed until the opposition fee has been paid. (Art. 99(1) European Patent Convention).

Description

BACKGROUND OF THE INVENTION

[0001] The present invention relates to a package-type fluidic apparatus in which a fluid machine such as a scroll compressor, a vacuum pump, an expander or a blower is connected to a drive source.

[0002] To reduce noise from a compressor and a drive source for driving it, they are often disposed within a package. A single high-output compressor is included within the package, or a plurality of low-output compressors are piled up to form a high-output compressor in a package.

[0003] In particular, when a compressor is used in a factory, in view of the maximum air consumption, a single high-output compressor for producing it is used within a package.

[0004] However, when air produced by a high-output compressor is used in a factory, the rate of operation is about 100 % all day long, while it decreases to less than 50 % depending on time in a day. According to a season in a year, compressed air consumption is variable and power source for driving a compressor cannot frequently be switched on and off when a high-output compressor is used.

[0005] In a medium-sized or large machine in which a large air tank is difficult to put, as frequency of starting and stopping increases, it becomes likely to generate heat during starting of a motor, to decrease life of an electromagnetic switch and to cause mechanical problem of a compressor, and a motor starting current of a compressor becomes five to six times as that of rated operation to involve decrease in power source. In a large machine, voltage of power source decreases owing to the starting current and adverse effects to transforming and distribution installation so as not to enable on/off of the power source frequently.

[0006] To solve such problems, for example, when output of the compressor is 15 kW, four compressors having output of 3.7 kW are included in a package. The compressors start with staggered time and the first, second, third and fourth compressors start in order to avoid the problem.

[0007] Depending on air consumption, it is possible to determine the optimum number of operation. Specifically, a plurality of compressors such as four are piled up to constitute a single package compressor, an example of such a single package compressor is given in XP 007900119. When it operates with about 100 % of compression air, all the four compressors operate. One of the four stops with about 70 % of air consumption; two stop with less than 50 %; three stop with further decrease; and all stop with further decrease.

[0008] Thus, electric power consumption is corresponding to the compression air consumption. Electric power consumption decreases compared with a single high-output compressor. If the compressor stops owing to any cause, capability for producing compression air

becomes null immediately in the single high-output compressor to result in stop of all machines in which compression air is used, thereby increasing damage in the factory.

[0009] On the contrary, in a plurality of compressors, even if one stops, it will avoid the risk that operation completely stops, as the others continue to operate. A plurality of compressors may preferably be employed.

[0010] In a plurality of compressors, a compressor and its drive source form a set of subsidiary unit. However, when a plurality of the subsidiary units are disposed horizontally or stepwise, a required area increases to unable its location. To decrease the area, a plurality of subsidiary units are vertically piled.

[0011] It is possible to pile them up, but is limited by height of a room and by how to transport. For maintenance of the taller compressor, a ladder must be used thereby increasing work of maintenance and involving danger.

[0012] It is already known on the market the Powerex system of the SE series which is a package-type fluidic machine consisting of three stacked units of scroll compressors placed in a single housing. A vertical exhaust duct is also provided.

[0013] JP 02-049458 discloses a cooling water supply device wherein two stacked units are placed on the opposite sides of a common duct-shaped path for the exhaust air flow. One embodiment of this document shows independent air inlets placed on the respective sides of the housings.

SUMMARY OF THE INVENTION

[0014] In view of the disadvantages, it is an object of the invention to provide a package-type fluidic apparatus that can be maintained without ladders or without increase in area thereby facilitating inspection and maintenance of the fluid machine, for example, in case of a scroll compressor, enabling a fixed scroll to be disassembled, tip seals of fixed and orbiting scrolls to be replaced, a bearing to be greased up and a subsidiary unit to be exchanged easily.

BRIEF DESCRIPTION OF THE DRAWINGS

[0015] The above and other features and advantages of the invention will become more apparent from the following description with respect to an embodiment as shown in appended drawings wherein:

Fig. 1 is a front perspective view of a best-mode embodiment of a package-type fluidic apparatus according to the present invention;

Fig. 2 is a front elevational view of Fig. 1, removing right and left front closing plates of a housing, electric wires to a motor and conduits to the fluid machine;

Fig. 3 is a front upper perspective view of Fig. 1, removing a top plate, the closing plates and an in-

spection door;

Fig. 4 is a top plan view in which the top plate is removed; and

Fig. 5 is a vertical sectional view taken along the line V-V in Fig. 2.

DETAILED DESCRIPTION OF PREFERRED EMBODIMENT

[0016] Two housings 2,2 each of which has four chambers 1 piled up are disposed with a space which is a sucking path 3. The housings 2,2 have the same shape and size, and the four chambers 1 have the same shape and size.

[0017] The sucking path 3 is closed by a removable inspection door 5 between front walls 4,4 over the housings 2,2. The upper part of the sucking path 3 is closed by an operation-display plate 5b. The rear end of the sucking path 3 opens, and external air is taken in through the rear opening.

[0018] The side ends of the operation-display plate 5b are mounted with screws to the opposing ends of the housings 2,2, and the operation-display plate 5b can be removed, if required. The inspection door 5 is removable by pushing down a slide latch 5a with a finger to open, so that sucking filters of fluid machines 8 in the housings 2,2 are inspected for maintenance.

[0019] On a bottom plate 6 of each of the chambers 1, a motor 7 and the fluid machine 8 such as a compressor or a decompression device behind the motor 7 are connected to pulleys 9,10 and a belt 11 to form a fluid machine unit 12.

[0020] In the chamber 1 of each of the housings 2,2, a sucking hole 14 is formed through the inner side wall 13 to allow each of the housings 2,2 to communicate with the sucking path 3. In the chamber 1 of each of the housings 2,2, an exhaust hole 16 is formed in a rear wall 15. A tall exhaust duct 17 is provided along the four exhaust holes 16 vertically arranged behind the housing 2. An electric exhaust fan 18 is provided in the top wall of the exhaust duct 17.

[0021] By driving the exhaust fans 18,18 and actuating the fluid machine units 12 positioned depending on gas volume to be pressurized or depressurized, a place where the gas is utilized and reaching time to a predetermined pressure, external air flows into the chamber 1 through the sucking path 3 and the sucking opening 14 and moves rearward. The air is discharged from the exhaust fan 18 through the exhaust duct 17.

[0022] Thus, the motor 7 and fluid machine 8 in the chamber 1 are cooled with external air, thereby avoiding overheat generated with continuous long-time operation and preventing damage to sliding parts.

[0023] The motor 7 and fluid machine 8 in the chamber 1 can be inspected and maintained by removing a closing plate at the rear end of the sucking path 3 and then removing the inner side wall 13 facing the sucking path.

[0024] The foregoing merely relates to an embodiment

of the invention. Various changes and modifications may be made by a person skilled in the art without departing from the scope of claims.

5

Claims

1. A package-type fluidic apparatus comprising two housings (2, 2) each comprising a plurality of chambers (1) piled up therein, an exhaust duct (17) being provided at a rear wall of each of the housings (2, 2), each of said chambers (1) having an exhaust hole (16) and a fluid-machine unit in which a fluid machine is connected to a drive source, the exhaust duct (17) being connected to the exhaust holes (16) of said chambers (1), and a sucking path (3) between the two housings (2, 2), **characterized in that:**

20

each of said chambers (1) has a sucking hole (14) formed in an inner side wall, the sucking path (3) opening at a rear end between the housings (2, 2) and allowing lateral access to the fluid machines on either side for the purpose of maintenance and inspection, each of said exhaust ducts (17) having an exhaust fan (18) to allow air in each of said chambers (1) sucked via the sucking path (3) and the sucking hole (14) to be discharged to outside via the exhaust holes (16) and the exhaust ducts (17) thereby increasing cooling efficiency to the fluid-machine unit.

25

30

2. A package-type fluidic apparatus as claimed in claim 1, wherein the two housings (2, 2) have substantially the same shape and size.

35

3. A package-type fluidic apparatus as claimed in claim 1, wherein a front end of the sucking path (3) is closed by an operation display plate (5b) and a removable inspection door (5) between the housings (2, 2).

40

Patentansprüche

1. Strömungsgerät mit mehreren Einheiten, umfassend zwei Gehäuse (2, 2), jedes davon umfassend eine Vielzahl von darin gestapelten Kammern (1), einen Auslasskanal (17), bereitgestellt an einer rückseitigen Wand jedes der Gehäuse (2, 2), wobei jede der Kammern (1) eine Auslassöffnung (16) und eine Strömungsgeräteeinheit aufweist, bei welcher ein Strömungsgerät mit einer Antriebsquelle verbunden ist, wobei der Auslasskanal (17) mit den Auslassöffnungen (16) der Kammern (1) verbunden ist, sowie einen Ansaugkanal (3) zwischen den zwei Gehäusen (2, 2), **dadurch gekennzeichnet, dass:**

50

55

jede der Kammern (1) eine Ansaugöffnung (14) aufweist, ausgebildet in einer inneren Seiten-

wand, wobei sich der Ansaugkanal (3) an einem rückseitigen Ende zwischen den Gehäusen (2, 2) öffnet und auf beiden Seiten einen seitlichen Zugang zu den Strömungsgeräten zu Zwecken der Wartung und Inspektion erlaubt, wobei jeder der Auslasskanäle (17) einen Absaugventilator (18) aufweist, um es der Luft in jeder der Kammern (1), welche über den Ansaugkanal (3) und die Ansaugöffnung (14) angesaugt wurde, zu ermöglichen, nach außen über die Auslassöffnungen (16) und die Auslasskanäle (17) abgeleitet zu werden, wodurch die Kühlwirkung auf die Strömungsgeräteeinheit erhöht wird.

2. Strömungsgerät mit mehreren Einheiten nach Anspruch 1, wobei die zwei Gehäuse (2, 2) im Wesentlichen die gleiche Form und Größe aufweisen. 15
3. Strömungsgerät mit mehreren Einheiten nach Anspruch 1, wobei ein frontseitiges Ende des Ansaugkanals (3) verschlossen ist mittels einer Betriebsanzeigetafel (5b) und einer abnehmbaren Inspektionsluke (5) zwischen den Gehäusen (2, 2). 20

25

Revendications

1. Appareil fluïdique à plusieurs unités comprenant deux logements (2, 2) comprenant chacun une pluralité de chambres (1) empilées dans ceux-ci, une conduite d'échappement (17) étant prévue sur une paroi arrière de chacun des logements (2, 2), chacune desdites chambres (1) possédant un orifice d'échappement (16) et une unité de machine fluïdique dans laquelle une machine fluïdique est raccordée à une source d'entraînement, la conduite d'échappement (17) étant raccordée aux orifices d'échappement (16) desdites chambres (1), et un passage d'aspiration (3) entre les deux logements (2, 2), **caractérisé en ce que** : 30

chacune desdites chambres (1) possède un orifice d'aspiration (14) formé dans une paroi latérale intérieure, le passage d'aspiration (3) s'ouvrant sur une extrémité arrière entre les logements (2, 2) et permettant un accès latéral aux machines fluïdiques de chaque côté dans le but de la maintenance et de l'inspection, chacune desdites conduites d'échappement (17) possédant un ventilateur d'échappement (18) pour permettre à l'air dans chacune desdites chambres (1) aspiré par l'intermédiaire du passage d'aspiration (3) et de l'orifice d'aspiration (14) d'être évacué vers l'extérieur par l'intermédiaire des orifices d'échappement (16) et des conduites d'échappement (17), augmentant ainsi l'efficacité de refroidissement de l'unité de machine fluïdique. 40 45 50 55

2. Appareil fluïdique à plusieurs unités selon la revendication 1, dans lequel les deux logements (2, 2) possèdent une forme et une taille sensiblement identiques.

3. Appareil fluïdique à plusieurs unités selon la revendication 1, dans lequel une extrémité avant du passage d'aspiration (3) est fermée par une plaque d'affichage de fonctionnement (5b) et une porte d'inspection amovible (5) entre les logements (2, 2).

FIG.1

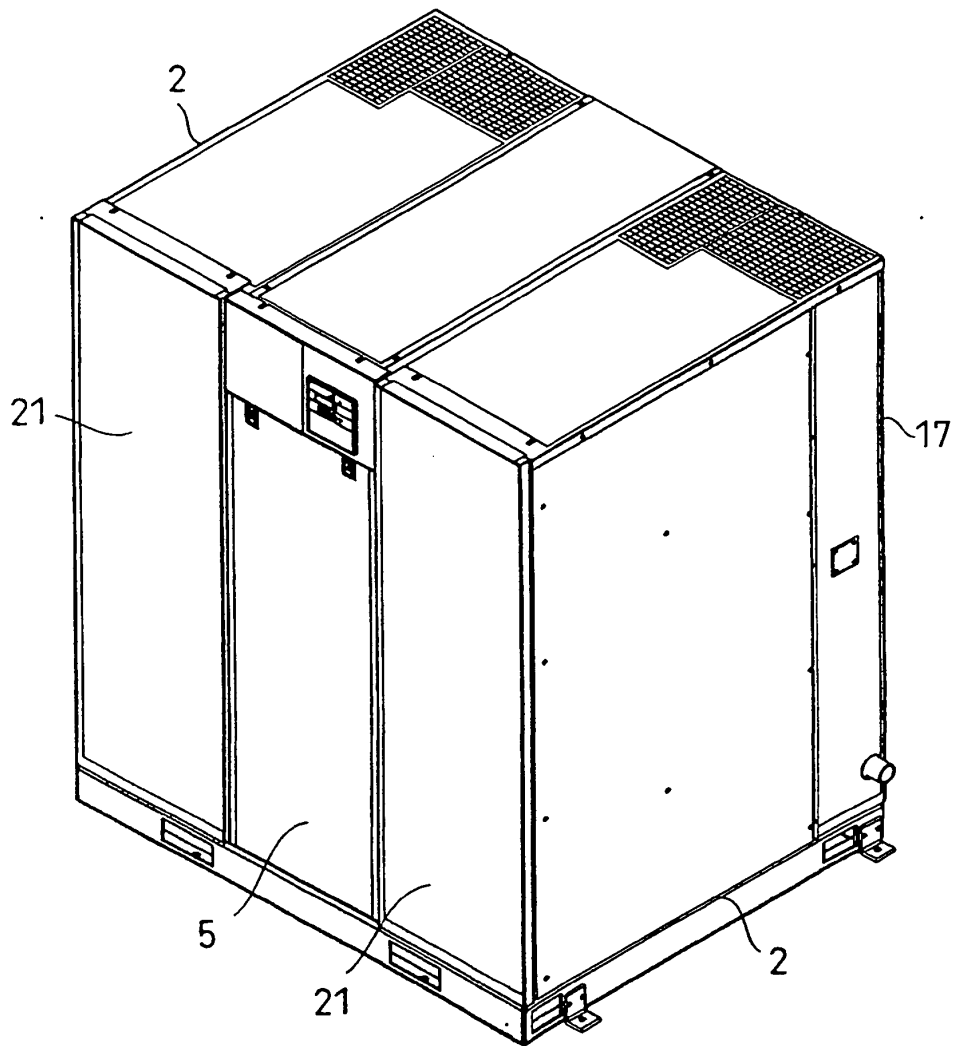

FIG.2

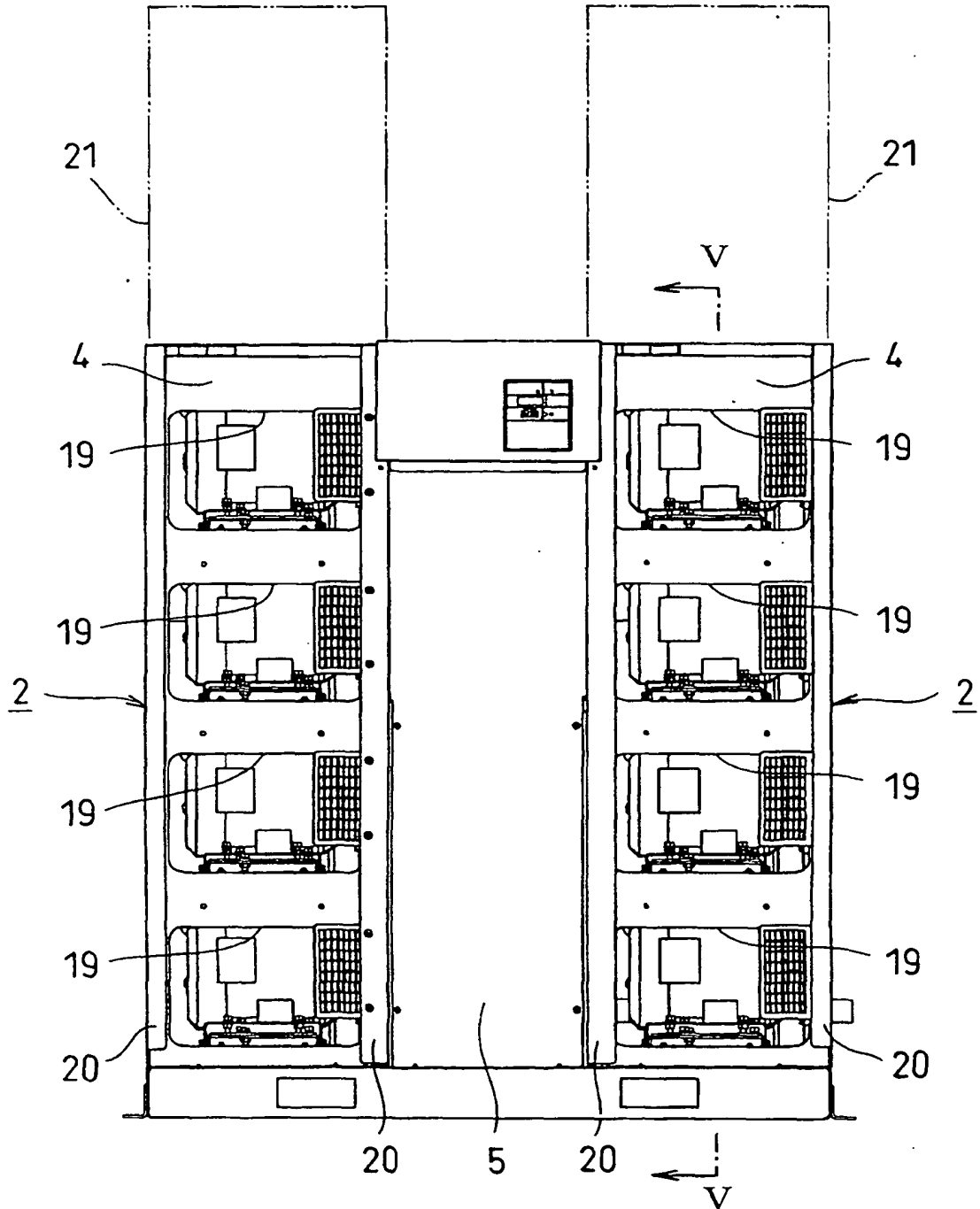

FIG.3

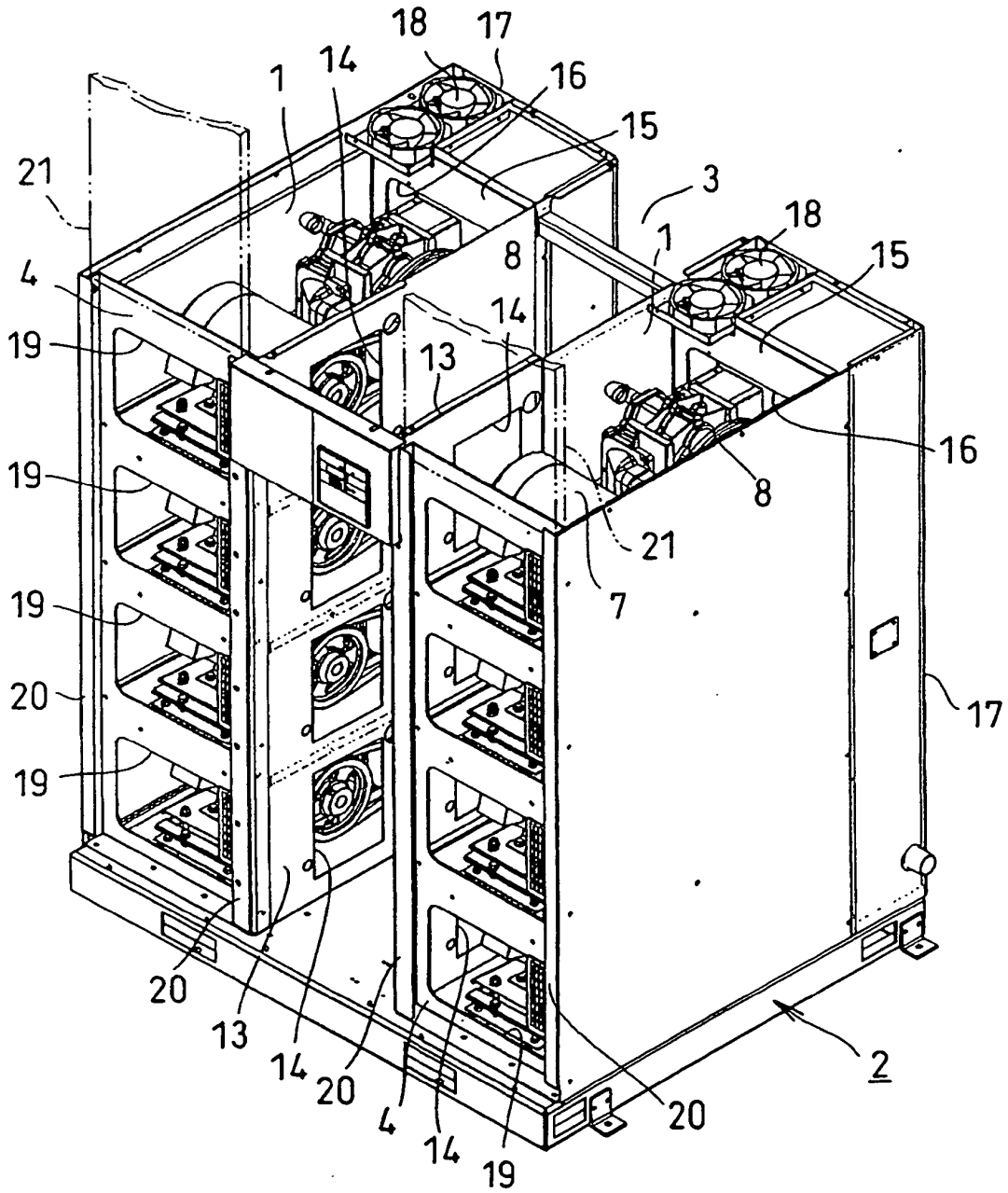

FIG.4

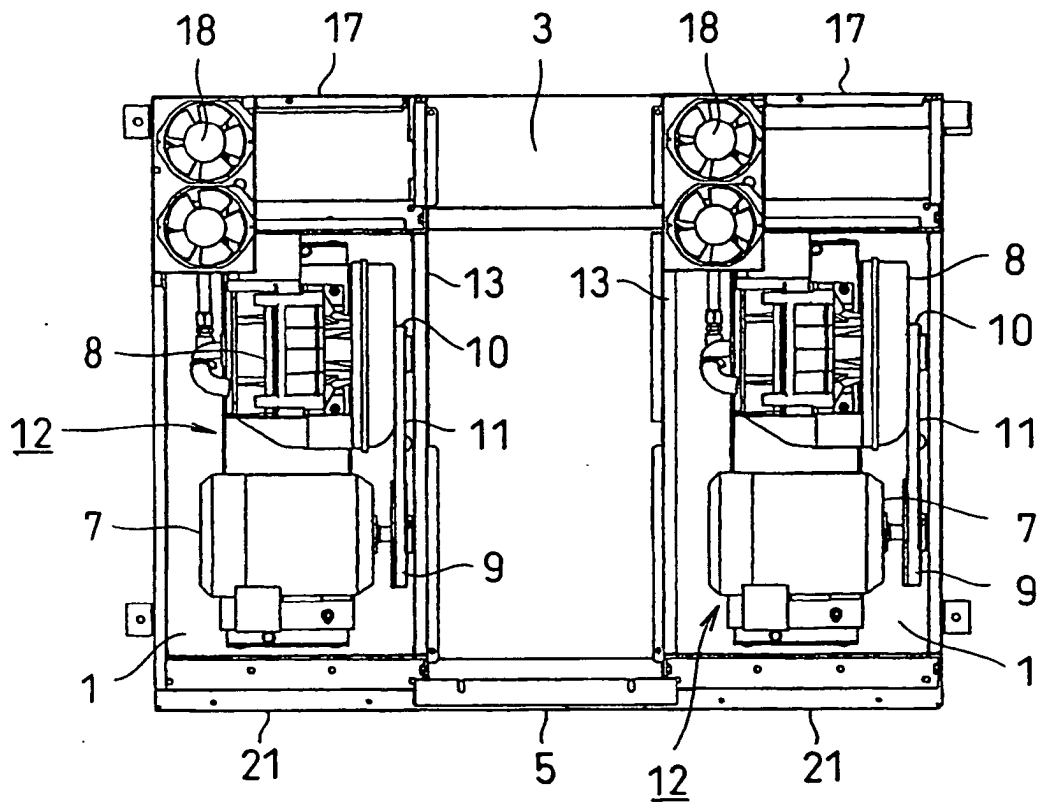
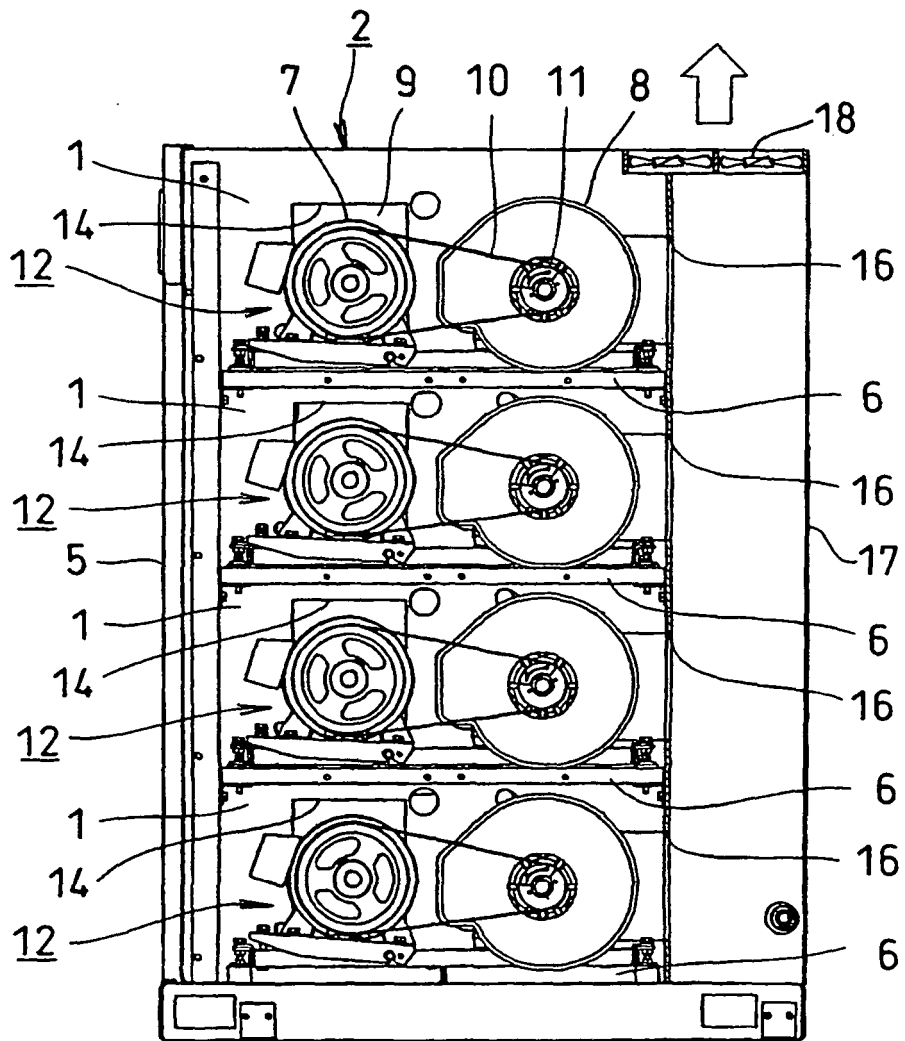

FIG.5



REFERENCES CITED IN THE DESCRIPTION

This list of references cited by the applicant is for the reader's convenience only. It does not form part of the European patent document. Even though great care has been taken in compiling the references, errors or omissions cannot be excluded and the EPO disclaims all liability in this regard.

Patent documents cited in the description

- JP 2049458 A [0013]