



- (51) International Patent Classification:
C09D 5/03 (2006.01) C09D 105/00 (2006.01)
C09D 103/02 (2006.01) C09D 189/00 (2006.01)
- (21) International Application Number:
PCT/GB2013/050890
- (22) International Filing Date:
5 April 2013 (05.04.2013)
- (25) Filing Language: English
- (26) Publication Language: English
- (30) Priority Data:
1206328.5 10 April 2012 (10.04.2012) GB
1206404.4 11 April 2012 (11.04.2012) GB
1207011.6 22 April 2012 (22.04.2012) GB
1207012.4 22 April 2012 (22.04.2012) GB
1207013.2 22 April 2012 (22.04.2012) GB
- (71) Applicant: NATURE PAINT LIMITED [GB/GB]; Unit 8, Marsh Lane Industrial Estate, Hayle, Cornwall TR27 5JR (GB).
- (72) Inventor: HARLING, Stuart Ross Rhind; Beechdown, Chicklade, Salisbury, Wiltshire SP3 5ST (GB).

- (74) Agent: HARDING, Charles; D Young & Co LLP, 120 Holborn, London EC1N 2DY (GB).
- (81) Designated States (unless otherwise indicated, for every kind of national protection available): AE, AG, AL, AM, AO, AT, AU, AZ, BA, BB, BG, BH, BN, BR, BW, BY, BZ, CA, CH, CL, CN, CO, CR, CU, CZ, DE, DK, DM, DO, DZ, EC, EE, EG, ES, FI, GB, GD, GE, GH, GM, GT, HN, HR, HU, ID, IL, IN, IS, JP, KE, KG, KM, KN, KP, KR, KZ, LA, LC, LK, LR, LS, LT, LU, LY, MA, MD, ME, MG, MK, MN, MW, MX, MY, MZ, NA, NG, NI, NO, NZ, OM, PA, PE, PG, PH, PL, PT, QA, RO, RS, RU, RW, SC, SD, SE, SG, SK, SL, SM, ST, SV, SY, TH, TJ, TM, TN, TR, TT, TZ, UA, UG, US, UZ, VC, VN, ZA, ZM, ZW.
- (84) Designated States (unless otherwise indicated, for every kind of regional protection available): ARIPO (BW, GH, GM, KE, LR, LS, MW, MZ, NA, RW, SD, SL, SZ, TZ, UG, ZM, ZW), Eurasian (AM, AZ, BY, KG, KZ, RU, TJ, TM), European (AL, AT, BE, BG, CH, CY, CZ, DE, DK, EE, ES, FI, FR, GB, GR, HR, HU, IE, IS, IT, LT, LU, LV, MC, MK, MT, NL, NO, PL, PT, RO, RS, SE, SI, SK, SM, TR), OAPI (BF, BJ, CF, CG, CI, CM, GA, GN, GQ, GW, ML, MR, NE, SN, TD, TG).

[Continued on next page]

(54) Title: COMPOSITION FOR USE AS A PAINT BINDER

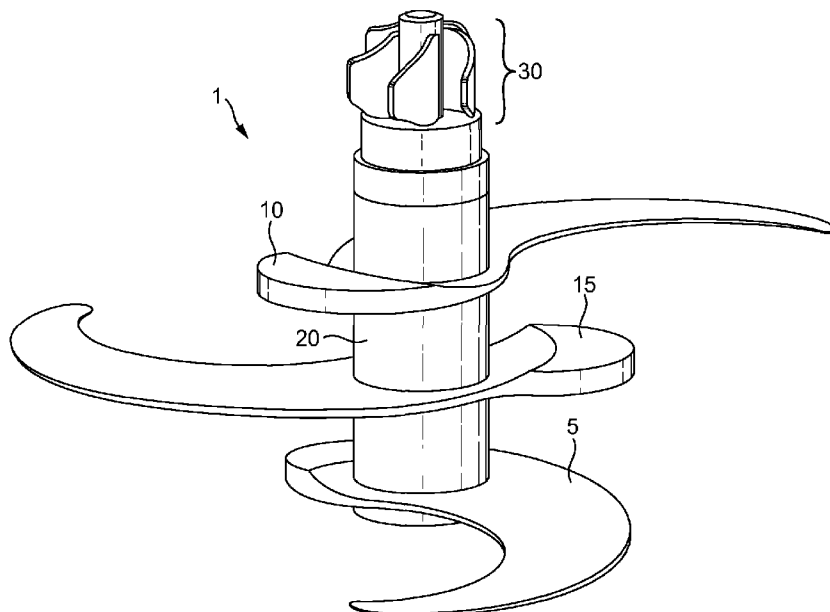

FIG. 1

(57) Abstract: A composition suitable for use as a paint binder is described. The composition comprises: a) a protein; b) a polysaccharide; c) an emulsifier; d) a thickening ingredient. The composition in a dry state has a homogeneous particle size of less than about 100 μm , preferably less than about 90 μm , preferably less than about 80 μm , preferably about 75 μm . In some embodiments it is preferred that the homogeneous particle size is between about 75 μm to about 100 μm .



Published:

— *with international search report (Art. 21(3))*

COMPOSITION FOR USE AS A PAINT BINDER

FIELD

5 The present invention relates to a process and a composition obtained from said process.

In particular, this invention relates to the fields of architectural or decorative coatings and paints in general and, more particularly, to binder compositions within non-toxic paints made from protein and other natural materials in dry-powder form and improved methods for
10 making the same, together with colouring pigments of a powdered or granulated form.

Even more particularly the present invention relates to such binders within a dry-powder paint formulation as will combine with a variety of liquids and other materials to achieve a range of different surface finishes, textures and appearances.

15

BACKGROUND

Typically, conventional paints are manufactured in liquid form to a pre-determined finish and texture. These paints comprise a binder (a 'glue-like' material), fillers, pigment and solvent
20 liquids which are subsequently packaged for customers within a metal or plastic container. The ingredients of such paints typically include a number of materials derived from petrochemicals and other high-carbon sources, many of which are considered hazardous to the environment and/or human life.

25 Generally the ingredients comprise petroleum and synthetic chemicals and solvents that are combined with bactericides, surfactants and other additives. The presence of such materials has been linked to a range of serious pathological conditions and emissions can continue without noticeable signs for a considerable period after the product has been applied. Evaporation of the solvents within conventional paints can also cause shorter term distress
30 to both humans and animals and is felt to be a trigger for headaches, migraines, breathing difficulties, asthma attacks and other health conditions.

It is also estimated that between 10-12% of conventional liquid paint products end up in the waste stream without being used for a variety of reasons including consumer confusion over
35 applicability, purchase of too much product and unsuitability of purchased paint for a particular finish.

Conventional liquid paint is typically blended from a combination of all ingredients in a large tank (500+ litres) and manufactured through a cutting process known as high-shear liquid dispersion which can take up to 12 hours or more. Such manufacture is a high energy process and the resultant product is heavy, difficult and costly to store and transport.

5

The manufacture, transportation, storage and disposal of conventional liquid paint products also poses additional emission risks, costs and hazards for the distributors, users and the waste disposal authorities of such products. Regulations are planned to limit the amount of toxic chemicals and solvents in such products and UK environmental landfill regulations now increasingly restrict the disposal of liquid paints and their containers by both professional painters and householders.

Even liquid paints advertised as 'low volatile organic compound (VOC)' and/or 'non-toxic to humans' may still contain solvents, bactericides and other ingredients harmful to the atmosphere, environment and other life forms, such as aquatic organisms.

In addition the increasing diversity of paint colours, surface applicability and finishes leads to the consumer making additional purchases of paint products, resulting in increased disposal and waste. The costs of safely disposing of some liquid paint ingredients are now estimated to be in the order of ten times the cost of manufacture.

Consequently there is a need for paints that can be manufactured and safely distributed in lightweight dry-powder forms. Moreover there is a need for non-toxic paints which do not contain hazardous or undesirable ingredients and do not constitute a health risk for humans, the environment or the atmosphere, and which preferably have little or none of the transportation and disposal problems associated with conventional liquid paints.

It has long been known that tolerable non-toxic paints can be produced from a range of earth minerals and natural materials in a dry-powder form to be mixed by the user with water and/or other liquids in the amounts required at time of use.

These 'natural' paints often include milk and plant proteins, in liquid or other forms (e.g. dry forms), and are of ancient origins. Such paints in dry-powder form, wherein the binder is the most critical component, have been variously referred to as milk paints, casein paints, casein-lime distempers, calcimines etc.

A number of formulations for such dry-powder paints have been granted patents in various countries over a period of many years and these have been reviewed in pursuance of this application, in particular US 2636829 A and GB 2443026 B.

5 Although produced in dry-powder form, many of these paints still require a considerable degree of skill in the art to produce satisfactory results by typical consumers when compared with the convenience of conventional ready-to-use liquid paints. For example, the resulting liquid mix can be liable to agglomeration of the casein granules producing a porridge-like and grainy texture. A blotchy and inconsistent colour finish can also result from insufficient
10 combination of the binder with the pigment material. The mixing of such paints can also produce excessive foaming, resulting in a mousse-like consistency that cannot be applied satisfactorily with normal tools.

Additional problems can occur when applying such paints over certain surfaces including
15 previous coats of conventional acrylic, or other petrochemical paints, as well as mixed material substrates such as gypsum, acrylic plasters and lime mortars. This can result in the rejection of the paint entirely, or cracking and flaking.

Another salient drawback is that the finish of such paints is often limited to a flat matt
20 appearance, which can be loose and rub off easily. This flat matt appearance can also restrict the applicability of such paints necessitating the use of other incompatible and hazardous products within the same location, thereby negating the benefits of non-toxic products.

25 Therefore there are benefits from making measurable improvements to such dry-powder paint products which will result in easier and more tolerant mixing with liquids; better adherence; with more consistent finish; and lower energy consumption in the manufacture and usage of such products.

30 Therefore there is an unaddressed need for a modern form of non-toxic dry-powder paint material that can be easily mixed with a variety of liquids by those of little prior skill to produce durable, attractive and varied finishes and an appearance that is suitable for application to a wide range of surfaces and substrates.

35 Furthermore such dry-powder paints would be advantageous to users and others if their packaging and any residues could be easily disposed of with minimal detrimental impact on the environment, atmosphere, humans and other life forms.

Despite the environmental benefits of such dry-powder paint products, there are, from customer experience and market knowledge, recognised issues concerning the perceived performance and consumer acceptance of such products.

5

From detailed investigation it is known these issues arise from:

- Lack of consistent mixing of materials and variable thickening time.
- Inconsistent particle size leading to powder 'flotation' of smaller particles and different
10 dissolving rates in water and other liquids.
- The effects of exposure of proteins within milk and plant materials to excessive heat during certain grinding and particle reduction procedures.
- The effects of exposure of dry-powder paint ingredients to moisture and/or humid atmosphere.
- 15 • The surface oxidation of oxide pigments and other colouring components which prevent intimate combination with other materials to produce full colour depth.

It is known that proteins of both plant and milk sources together with naturally derived polysaccharides, lecithin and cellulose materials have certain characteristics which can be
20 damaged or modified through the action of heat, pressure and moisture.

Accepted and known industry practice in the processing of powders and for reducing particle sizes involves grinding or milling of one particular type of material at a time. "Grinding" is thus defined as to crush, pulverize, or reduce to powder by friction, especially by rubbing
25 between two hard surfaces.

The established milling technology used for powder particle reduction thus relies on the action of striking particular materials between two harder surfaces and includes: Ball Mills, Conical Mills, Hammer Mills, Edge Mill, Planetary Mill, Roller Mills, Wiley Mills, Disk Mills and
30 Plate Mills.

Inevitably the mechanical actions involved all produce friction, pressure and heat which are detrimental to the combined ingredients of natural dry-powder paints. The extended periods of such processing can also expose the materials to atmospheric moisture which can
35 degrade the final product performance.

In addition the majority of mechanical milling technologies rely on screens to separate out particles of particular sizes. In the nature of the soft and sticky ingredients included in such 'natural' paints, these screens can soon become blocked and milling has to cease completely whilst a protracted clean down takes place.

5

In the powder processing industry certain adaptations to the established procedures have been made in order to improve conventional milling technology when processing batches of soft materials. One form is 'cryogenic' milling where the particular material to be processed is either frozen or liquid nitrogen is introduced into the milling chamber in order to keep temperatures at low levels. A second is 'air-jet' milling where particles interact and collide with each other in powerful air streams.

Both of these milling adaptations have proved unsatisfactory in the processing of the combined ingredients found in dry-powder binders and paints for a variety of reasons including: moisture retention, energy cost, pressure damage, heat generation, environmental impact or the time required to process cost effective quantities of product.

The present invention provides a dry process for reducing a dry-powder binder of various particle sizes through cutting and slicing (shearing) actions. The action of shearing the materials described imposes less pressure and generates less friction and heat than other particle reduction methods.

SUMMARY OF INVENTION

In one aspect, the present invention provides a composition suitable for use as a paint binder, said composition comprising:

a protein;

a polysaccharide;

an emulsifier;

30 a thickening ingredient;

wherein said composition in a dry state has a homogeneous particle size of less than about 100 μm , preferably less than about 90 μm , preferably less than about 80 μm , preferably about 75 μm .

35 In some embodiments it is preferred that the homogeneous particle size of said composition in a dry state is between about 75 μm to about 100 μm .

The present invention also provides a method of manufacturing the composition of the present invention, comprising subjecting components of the composition to a dry shearing process.

- 5 The present invention also provides a composition obtainable from the method according to the present invention.

The present invention also provides a paint comprising the composition according to the present invention.

10

The present invention also provides a liquid paint comprising the composition according to the present invention.

- 15 The present invention also provides a method of manufacturing a paint according to the present invention.

The present invention also provides a method of manufacturing a liquid paint according to the present invention.

- 20 The present invention also provides a coloured liquid paint obtained from mixing the composition of the present invention with a fluid vehicle; wherein the colour of the liquid paint is predominantly due to a colourant present in said composition.

- 25 The present invention also provides a coloured liquid paint obtained from mixing the composition of the present invention or a composition obtainable from the method of the present invention with a fluid vehicle; wherein the colour of the liquid paint is at least predominantly due to a colourant present in said composition.

- 30 The present invention also provides a coloured liquid paint obtained from mixing the composition of the present invention with a fluid vehicle; wherein the colour of the liquid paint is solely due to a colourant present in said composition.

- 35 The present invention also provides a coloured liquid paint obtained from mixing the composition of the present invention or a composition obtainable from the method of the present invention with a fluid vehicle; wherein the colour of the liquid paint is in part or totally due to a colourant added to said fluid vehicle, said colourant being distinct from said composition.

The present invention also provides a method of applying a paint according to the present invention to a surface.

- 5 The present invention also provides a method of applying a liquid paint according to the present invention to a surface.

The present invention also provides use of the composition according to the present invention to reduce the levels of volatile organic compounds in a paint.

10

The present invention also provides use of the composition according to the present invention to reduce the levels of volatile organic compounds in a liquid paint.

- 15 The present invention also provides for the use of a paper based container containing the composition of the present invention or a composition obtainable from the method according to the present invention. The container may be a sachet, pouch or wallet. The container may be a box. The paper based element may be paper or cardboard, or combinations thereof. The composition of the present invention or a composition obtainable from the method according to the present invention may be held in a plastic or wax lined container –
20 such as a bag – in the paper based container.

- Advantages of the present invention are that it leads to improvements in the production of a dry-powder paint binder composition that is non-toxic dry-powder paint that may be subsequently mixed with a variety of fluid vehicles to form a paint that may be applied to
25 different surfaces and/or to yields different finishes, textures and appearances.

The present invention also provides a method for making a dry-powder paint binder composition with reduced time and energy consumption.

- 30 In a highly preferred aspect, the present invention provides a composition suitable for use as a paint binder, said composition comprising: a) a protein; b) a polysaccharide; c) an emulsifier; and d) a thickening ingredient; and a water conditioning component; wherein said composition in a dry state has a homogeneous particle size of less than about 100 μm . The present invention also provides a paint, preferably a liquid paint, comprising said
35 composition. Preferably said paint also comprises a colorant.

In a highly preferred aspect, the present invention provides a composition suitable for use as a paint binder, said composition comprising: a) a protein; b) a polysaccharide; c) an emulsifier; and d) a thickening ingredient; and a water conditioning component; wherein said composition in a dry state has a homogeneous particle size of less than about 100 µm; and
5 wherein said composition or at least a part thereof is prepared by subjecting components of the composition to a shearing process. The present invention also provides a paint, preferably a liquid paint, comprising said composition. Preferably said paint also comprises a colorant.

10 In a highly preferred aspect, the present invention provides a composition suitable for use as a paint binder, said composition comprising: a) a protein; b) a polysaccharide; c) an emulsifier; and d) a thickening ingredient; and a water conditioning component; wherein said composition in a dry state has a homogeneous particle size of less than about 100 µm;
15 wherein said composition or at least a part thereof is prepared by subjecting components of the composition to a shearing process; and wherein said shearing process uses an apparatus comprising horizontal and vertical blades, wherein said vertical blades contain spiral fluting and are located at one end of a vertical cylindrical blade shaft and further wherein said horizontal blades are rotatable in the horizontal plane about said vertical cylindrical blade shaft. The present invention also provides a paint, preferably a liquid paint,
20 comprising said composition. Preferably said paint also comprises a colorant.

A number of advantages are associated with each of these highly preferred aspects. The binder composition disperses more quickly and yields a smoother product. It also has improved covering power on normal decorating surfaces. It does not agglomerate in
25 solution. It retards gelling. It maintains a usable pot life of 2-3 days or more. It maintains a pH level sufficiently high to act as a mildewcide. It does not separate, stratify or settle out overnight. It enables a uniform distribution of coloured particles, meaning that the resultant paint is non streaky or blotchy.

30 **BRIEF DESCRIPTION OF THE FIGURES**

Figure 1 is a diagram of a shearing mechanism for use in the present invention.

Figure 2 is a graph.

Figure 3 is a graph.

35 Figure 4 is a graph.

Figure 5 is a photographic image.

Figure 6 is a photographic image.

Figure 7 is a photographic image.

Figure 8 is a photographic image.

PREFERRED ASPECTS

5

Preferably, said protein is a protein derived from milk.

Preferably, said protein is casein.

10

Preferably, said protein is acid casein.

Preferably, said polysaccharide is a glucose polymer.

Preferably, said polysaccharide is dextrin.

15

Preferably, said emulsifier comprises at least one phospholipid moiety.

Preferably, said emulsifier is lecithin.

20

Preferably, said emulsifier is soy lecithin.

Preferably, said thickening ingredient is a fibrous material.

Preferably, said thickening ingredient is a carbohydrate-based fibrous material.

25

Preferably, said thickening ingredient is a glucose polymer.

Preferably, said thickening ingredient is a cellulosic material.

30

Preferably, said thickening ingredient is cellulose.

Preferably, said composition further comprises a preservative.

Preferably, said preservative is a fungicidal preservative.

35

Preferably, said preservative is independently selected from zinc oxide, potassium sorbate or borax, or combinations thereof.

Preferably, said composition further comprises an antifoaming ingredient.

Preferably, said antifoaming ingredient is clay, such as bentonite.

5

Preferably, said composition further comprises a water conditioning component. The water conditioning component is sometimes referred to as a dispersant.

10

The presence of the water conditioning component yields a series of advantages. For example, it permits a better control of the progress of the gelling process of the paint. It also compensates pH variability in the user's mixing water. It also offsets the gradual deterioration in the 'activation' capabilities of the slaked lime (if used).

15

Preferably, the composition of the present invention is prepared by subjecting the components of the composition to a rotary shearing process.

Preferably, said shearing process is driven by electrical or mechanical means.

20

Preferably, said shearing process is uses an apparatus with blades.

Preferably, said apparatus comprises horizontal and vertical blades.

Preferably, vertical blades are fluted.

25

Preferably, said vertical blades contain spiral fluting.

Preferably, said vertical blades contain spiral fluting and are located away from the horizontal blades.

30

Preferably, said vertical blades contain spiral fluting and are located at one end of a vertical cylindrical blade shaft.

35

Preferably, said vertical blades contain spiral fluting and are located at one end of a vertical cylindrical blade shaft and further wherein said horizontal blades are rotatable in the horizontal plane about said vertical cylindrical blade shaft.

Preferably, said composition is present in the paint in an amount from about 10% to about 50% by weight.

5 Preferably, said composition is present in the paint in an amount from about 14.45% to about 38.2% by weight.

Preferably, said composition is present in the paint in an amount from about 15.5% to about 32% by weight.

10 Preferably, said paint is in a dry powder state.

Preferably, said paint further comprises one or more of: a pigment; an activator; a filler mixture.

15 Preferably, a pigment is present and wherein said pigment is a granulated pigment.

Preferably, a pigment is present and wherein said pigment is an organic or inorganic pigment.

20 Preferably, a pigment is present and wherein said pigment is independently selected from the list: ochres, oxides, dioxides, umbers, vegetable dyes and naturally occurring earth pigments.

25 Preferably, a pigment is present and wherein said pigment is present in an amount from about 0.5% to about 20% by weight.

Preferably, an activator is present and wherein said activator is a binder activating material.

30 Preferably, an activator is present and wherein said activator is independently selected from the list: calcium hydroxide, ammonium carbonate and borax.

Preferably, an activator is present and wherein said activator is present in an amount from about 1% to about 10% by weight.

35 Preferably, a filler mixture is present and wherein said filler mixture is a mineral filler mixture.

Preferably, a filler mixture is present and wherein said filler mixture is independently selected from the list: kaolin, talc, barites, dolomites, clays, marbles such as marble dust, silicates such as magnesium silicate, carbonates such as calcium carbonate (chalk) or other white inert materials

5

Preferably, a filler mixture is present and wherein said filler mixture is present in an amount from about 50% to about 70% by weight.

Preferably, said fluid vehicle is an aqueous solvent, preferably water.

10

Preferably, said liquid paint further comprises one or more fluid paint excipients, additional diluents or additional carriers.

15

Preferably, said excipient, diluent or carrier is independently selected from the list: water, wax emulsions, beeswax emulsion, gums, glues, linseed oil, safflower oil and tung oil, or combinations thereof.

20

Preferably, the composition of the present invention that is suitable for use as a paint binder, wherein said composition comprises at least a protein, a polysaccharide, an emulsifier and a thickening ingredient is prepared by shearing. In a shearing process, such as the process described herein, one or more of the components of the composition are sheared until the particles in a dry state have a homogeneous particle size of less than about 100 μm , preferably less than about 90 μm , preferably less than about 80 μm , preferably about 75 μm . In some embodiments it is preferred that the homogeneous particle size of said composition

25

in a dry state is between about 75 μm to about 100 μm .

Preferably, the composition of the present invention that is suitable for use as a paint binder, wherein said composition comprises at least a protein, a polysaccharide, an emulsifier and a thickening ingredient is prepared by shearing. In a shearing process, such as the process

30

described herein, at least two components of the composition are sheared until the particles in a dry state have a homogeneous particle size of less than about 100 μm , preferably less than about 90 μm , preferably less than about 80 μm , preferably about 75 μm . In some embodiments it is preferred that the homogeneous particle size of said composition in a dry state is between about 75 μm to about 100 μm .

35

Preferably, the composition of the present invention that is suitable for use as a paint binder, wherein said composition comprises at least a protein, a polysaccharide, an emulsifier and a

thickening ingredient is prepared by shearing. In a shearing process, such as the process described herein, at least three components of the composition are sheared until the particles in a dry state have a homogeneous particle size of less than about 100 μm , preferably less than about 90 μm , preferably less than about 80 μm , preferably about 75 μm .

5 In some embodiments it is preferred that the homogeneous particle size of said composition in a dry state is between about 75 μm to about 100 μm .

Preferably, the composition of the present invention that is suitable for use as a paint binder, wherein said composition comprises at least a protein, a polysaccharide, an emulsifier and a thickening ingredient is prepared by shearing. In a shearing process, such as the process
10 described herein, at least four components of the composition are sheared until the particles in a dry state have a homogeneous particle size of less than about 100 μm , preferably less than about 90 μm , preferably less than about 80 μm , preferably about 75 μm . In some embodiments it is preferred that the homogeneous particle size of said composition in a dry
15 state is between about 75 μm to about 100 μm .

Preferably, the composition of the present invention that is suitable for use as a paint binder, wherein said composition comprises at least a protein, a polysaccharide, an emulsifier and a thickening ingredient is prepared by shearing. In a shearing process, such as the process
20 described herein, substantially all of the components of the composition are sheared until the particles in a dry state have a homogeneous particle size of less than about 100 μm , preferably less than about 90 μm , preferably less than about 80 μm , preferably about 75 μm . In some embodiments it is preferred that the homogeneous particle size of said composition in a dry
25 state is between about 75 μm to about 100 μm .

Preferably, the composition of the present invention that is suitable for use as a paint binder, wherein said composition comprises at least a protein, a polysaccharide, an emulsifier and a thickening ingredient is prepared by shearing. In a shearing process, such as the process
30 described herein, all of the components of the composition are sheared until the particles in a dry state have a homogeneous particle size of less than about 100 μm , preferably less than about 90 μm , preferably less than about 80 μm , preferably about 75 μm . In some embodiments it is preferred that the homogeneous particle size of said composition in a dry
35 state is between about 75 μm to about 100 μm .

DETAILED DESCRIPTION OF INVENTION

For clarity of disclosure, and not by way of limitation, the detailed description of the invention is divided into the following subsections which describe or illustrate certain features, 5
embodiments or applications of the invention.

It has been unexpectedly found that paint binder compositions comprising a mixture of a source of protein, a polysaccharide, an emulsifier and thickening ingredient and having homogeneous particle size of less than about 100 μm , preferably less than about 90 μm , 10
preferably less than about 80 μm , preferably about or more than about 75 μm (in some embodiments it is preferred that the homogeneous particle size of said composition in a dry state is between about 75 μm to about 100 μm) have advantageous properties. Examples of advantageous properties include easier and more tolerant mixing with liquids; better adherence; more consistent finish; and lower energy consumption in the manufacture and 15
usage of such products.

It has been unexpectedly found that phospholipid-based emulsifiers such as soy lecithin act beneficially upon the chemical reaction between the casein protein and its activating material, believing it to break down the fat components within the casein and reducing its 20
propensity to agglomerate and clump when mixed with water.

It has been unexpectedly found that thickening ingredients such as cellulose fibres reduce the tendency of the final paint product to separate, run and splatter when applied to vertical or horizontal surfaces with normal paint application tools, and also reduce or prevent 25
cracking of the dried paint surface.

It has been unexpectedly found that polysaccharide such as dextrin increases the dispersion and adherence of the pigment component in application of the paint and reduces any initial rubbing off of the paint product prior to the curing of the paint product through evaporation and carbonisation. 30

It has been unexpectedly found that the performance of the overall paint produced is measurably enhanced when the said binder components are mixed, ground to micron fineness prior to inclusion with other components of a dry-powder paint. 35

It has been unexpectedly found that such binder may be used in various proportions with other materials to produce a dry-powder paint that combines satisfactorily with a range of

liquids to produce an acceptable quality of paint which produces, or can be caused to produce, different surface finishes, appearances and textures after drying.

5 It has been found that such binders when combined with said other materials to form a dry-powder paint are capable of indefinite storage in a wide range of moisture-proof packaging without noticeable degradation or loss of performance.

10 It has been unexpectedly found that such binder when combined with said other materials to form a dry-powder paint has no known detrimental impacts on the environment, atmosphere, human or other life and will biodegrade over time.

Based on these discoveries, the present invention provides a composition useful as a paint binder made from natural and non-toxic materials.

15 The present invention provides compositions useful as a paint binder comprising a mixture of a source of protein, a polysaccharide, an emulsifier and thickening ingredient. Methods of making these compositions by subjecting the components to a dry shearing process/micronising milling are also provided.

20 The paint binder composition of the present invention is made in a way which can be combined with a variety of dry mineral fillers, other ingredients and colourants of various types to make a dry decorating paint powder.

25 Thus, the present invention provides a novel development in the manufacture of powdered paint binder compositions made from protein and natural materials. Also provided is the incorporation of such binder compositions with fillers, pigments and other materials in the production of a dry-powder paint, to be mixed with liquids in order to form a usable and durable architectural and decorative coating material.

30 The paint binder composition may be manufactured in a variety of ways by grinding individual ingredients to an acceptable particle size and then mixing by a tumbling or ribbon mixing process. Alternatively individual components thereof can be batched and combined for intermediate processing and then subsequently mixed with the other ingredients.

35 Alternatively, the components of the paint binder composition of the present invention together with one or more, preferably all, of the other components - such as fillers, additives, colourants and water conditioning components - can be processed separately or

alternatively combined together for satisfactory particle reduction and milling in one stage through the use of a dry shearing process, such as a dry shearing process comprising the use of a rotary blade processor, such as the device described herein.

- 5 The paint binder composition of the present invention can be packaged and sealed into a wide range of moisture-preventative containers, distributed to customers and subsequently mixed with a suitable fluid vehicle, such as water, such as locally supplied water to make a decorating paint. The paint binder composition powder can also be mixed with a combination of water and other liquids to vary the paint surface appearance and performance.
- 10 Depending on the composition of the paint binder composition, additional ingredients may be added to the fluid vehicle before, during or after addition, or combinations thereof, of the paint binder composition of the present invention to the fluid vehicle. These additional ingredients may include fillers, additives, colourants and water conditioning components.
- 15 Optionally, the dry mineral fillers mixed with the paint binder composition can include clays, kaolin, talcs, carbonates, barites, dolomites, marbles, etc.

Optionally, the colouring materials mixed with the paint binder composition can include natural and synthetic pigments in a variety of dry forms.

20

Optionally, these colouring materials may either be combined with all other ingredients at point of manufacture, or supplied separately to be combined by the customer with the mixing water before addition of the paint powder. In the latter option the range of colouring components can be extended to include liquid dyes and pigments.

25

Optionally, the paint binder composition and paint powder may also contain additives and agents which provide additional paint capabilities such as thickening, anti-mould, improved slip, faster drying, etc.

- 30 Optionally, the paint binder composition and paint powder may also contain a water conditioning component to offset the effect of variations found in local water hardness and alkalinity.

In one aspect, the paint binder composition of the present invention is mixed with a suitable
35 fluid vehicle and a colourant so as to yield a paint – such as a decorating paint – that is ready for use.

In one preferred aspect, the paint binder composition of the present invention, when mixed with just a suitable fluid vehicle, yields a paint – such as a decorating paint – that is ready for use.

5 PAINT BINDER COMPOSITION

In one embodiment, the present invention provides compositions useful as a paint binder comprising a mixture of a protein, a polysaccharide, an emulsifier and thickening ingredient.

10 Binder compositions of the present invention are formulated and manufactured to be combined with a variety of fillers, pigments and additives to produce a non-toxic dry-powder paint which will combine satisfactorily with a range of liquids to produce durable, attractive and varied paint finishes and appearances on a range of surfaces and substrates.

15 Generally the binder of the present invention is made up of components that include a source of protein, a polysaccharide and other materials and techniques that have become more recently available such as an emulsifier, a thickening ingredient and the process of micronising milling.

20 The compositions of the present invention typically include one or more proteins.

Proteins suitable for use in the compositions of the present invention include proteins derived from milk. Preferred sources of protein include casein.

25 The compositions of the present invention typically include one or more polysaccharide.

Polysaccharides suitable for use in the compositions of the present invention include starch-based polysaccharides. Preferred starch-based polysaccharides include dextrans.

30 The compositions of the present invention typically include one or more emulsifiers.

Emulsifiers suitable for use in compositions of the present invention include biologically natural emulsifiers. Preferred biologically natural emulsifiers include phospholipid compounds or a mixture of phospholipids. Preferred phospholipids are phosphatidylcholine
35 (lecithin), such as soy lecithin.

The compositions of the present invention typically include one or more thickening ingredients.

Thickening ingredients suitable for use in compositions of the present invention include
5 fibrous materials. Preferred fibrous materials include polysaccharides such as cellulose.

MICRONISING MILLING

In another embodiment, the present invention provides a process for reducing a dry-powder
10 binder particle size through cutting and slicing (shearing) actions. The action of shearing the materials described imposes less pressure and generates less friction and heat than other particle reduction methods.

To produce the said binder compound, the four principal components are provided in specific
15 quantities and are mixed and processed prior to inclusion with other ingredients of a non-toxic dry-powder paint. Although these are four of the ingredients, other components that are compatible with these four may be added if desired.

In one aspect, each individual component of the paint binder composition and other paint
20 ingredients (e.g. filler, colourant, activator) is sheared separately, and then each component is subsequently mixed together.

In an alternative aspect, any two or more components of the paint binder composition or
25 other paint ingredients are sheared together, and then subsequently mixed with other sheared or non-sheared components of the paint binder composition.

In an alternative aspect, all components of the paint binder composition and other paint ingredients are sheared together.

30 In various trials, it was found that the particle size of 'natural' ingredients could be reduced through the shearing interaction of specially developed horizontally mounted blades rotated at speeds of between 1500 and 3000 rpm through a batch of the combined materials.

COLOURING AND PIGMENTATION

Architectural and decorative paints and coatings for surfaces which are to be given a coloured appearance are usually modified by the inclusion of one or more pigments.

5

The nature of the colourants – sometimes called pigments - to be included in the present invention may be from those supplied in powder or granulated form. Where incorporated in granulated form such pigments, sometimes known as 'stir-in' pigments, may be included with both the paint binder and dry paint powder.

10

The colourants may include natural and/or synthetic pigments in a variety of dry forms.

In a preferred aspect suitable granulated pigment preparations are of a type that are commercially available, for example, those by BASF under the trademark "X-Fast®", by Lanxess Deutschland GmbH under the trademark "LEVANYL® Gran" and "LEVANOX® Gran", by Clariant under the trademark "Colanyl®400 Reibe" and by Rockwood Pigments (Brockhues) and the trademark "Granufin®".

15

The colourants can be present in the paint binder composition of the present invention and/or they can be added before or during or after addition, or combinations thereof, of the of the paint binder composition of the present invention to a suitable fluid vehicle.

20

Hence, the colourants may either be combined with all other ingredients at the point of manufacture, or supplied separately to be combined by the customer with the mixing water before addition of the paint powder. In the latter option the range of colouring components can be extended to include liquid dyes and pigments.

25

Alternatively such granulated pigments may first be dissolved in the mixing water or other liquid to be mixed with the paint binder and dry paint powder which is manufactured from said paint binder.

30

Accordingly, in one aspect, the colourant may be added to the paint binder composition before, during or after the dry shearing process.

35

In an alternative aspect, the paint binder composition of the present invention need not necessarily contain a colourant

In an alternative aspect, the colourant may be added into a fluid vehicle. The colourant may be added to the fluid vehicle either before, during or after the addition of the paint binder composition to the fluid vehicle.

5 HOMOGENEOUS PARTICLE SIZE

The term "homogeneous particle size" means that at least 90%, more preferably at least 95%, more preferably at least 96%, more preferably at least 97%, more preferably at least 98%, more preferably at least 99%, of the particles have a size of less than about 100 μm , preferably less than about 90 μm , preferably less than about 80 μm , preferably about 75 μm .

In some embodiments it is preferred that the homogeneous particle size of said composition in a dry state is between about 75 μm to about 100 μm .

Preferably, the term "homogeneous particle size" means that at least 95%, more preferably at least 96%, more preferably at least 97%, more preferably at least 98%, more preferably at least 99%, of the particles have a size of less than about 90 μm , preferably less than about 80 μm , preferably about 75 μm . In some embodiments it is preferred that the homogeneous particle size of said composition in a dry state is between about 75 μm to about 100 μm .

Preferably, the term "homogeneous particle size" means that at least 96%, more preferably at least 97%, more preferably at least 98%, more preferably at least 99%, of the particles have a size of less than about 80 μm , preferably about 75 μm . In some embodiments it is preferred that the homogeneous particle size of said composition in a dry state is between about 75 μm to about 100 μm .

Preferably, the term "homogeneous particle size" means that at least 96%, more preferably at least 97%, more preferably at least 98%, more preferably at least 99%, of the particles have a size of about 75 μm .

ADDITIONAL ADVANTAGES

The inclusion of said binder compound in a dry-powder paint formulation enables users to produce a paint product that is advantageous over both conventional liquid paint and other dry-powder paints in respect of:

- Homogenous smooth mix that has the expected consistency of paint
- Ability to combine with a wide variety of liquids including oils, waxes, glues to produce a satisfactory paint product with different characteristics for different finishes and surfaces
- 5
- Better adhesion to a variety of surfaces and substrates
- Less paint 'splatter' or 'runs' when applied to vertical surfaces
- Colour is consistent over large areas without blotchiness
- Coverage density and area is consistent with conventional paint
- 10
- No noxious fumes or apparent ill effects to users or household
- Dries within 1-2 hours and rooms can be reused immediately
- No need for separate primer or undercoat prior to application on most surfaces
- No need for additional products to produce matt, eggshell, silk and semi-gloss finishes on a wide variety of surfaces.
- 15
- Fast clean up with plain water, with no need for special solvents
- Residues are biodegradable and can be safely composted with normal garden materials.

Furthermore, it was found that the action of horizontally mounted blades through a dry-powder paint binder composition induces a strong vortex effect within the combined materials which ensured thorough mixing of all ingredients and presentation to the cutting edges of the blades. The cooling effect of the vortex airstream allows the processing period to be shortened and without generating sufficient heat to cause damage to the protein materials.

25

With such a device, it has been found that it is possible to produce a homogeneous mixture of the ingredients within a 'natural' paint binder and to reduce the particle size consistently and uniformly.

30 It has been found that the shearing and cutting action of such horizontally mounted blades can reduce the time required to reduce particle size by 75% or more compared to other particle reduction techniques.

It has been found that the particles are uniformly reduced and can pass through the mesh of a sieve with 200 holes per square inch.

35

It has been found that, with a sufficiently powerful motor to drive the blades of such horizontal cutter blades the energy consumed is reduced over alternative grinding methods by over 25%.

- 5 It has been found that the shearing action can be induced to combine other particles with the paint binder in an equally uniform and homogeneous manner.

It has been found that the colour intensity of natural earth and oxide pigments is enhanced by the shearing action of such processing and therefore the amount of colourant required to
10 achieve certain colours can be reduced by up to 2.5%.

It has been found that a resulting protein binder composition will combine and thicken with water at a 10°C Celsius lower temperature than previously necessary thereby resulting in reduced energy requirements and mixing time by the user of the product.
15

It has been found that the resulting paint product produces a paint which has 15% improved adhesion properties when measured by the cross hatch adhesion test.

With regard to the colouring applications, the main advantage is the ability to mix the
20 hydrophilic granular pigments in the mixing water before adding the paint powder and thereby producing a paint of a known colour. This means the granular pigments can be supplied in a separate small packet or sachet, from the bulk pack of generic base paint. These 'dry' uses of granular pigments will not work with untreated pigments because they require pre-slaking with alcohol or pre-mixing into a paste. All the other established
25 uses of the granular pigments are either pre-combined with the paint material or added to the finished liquid paint.

The present invention provides a composition suitable for use as a paint binder, or a component thereof, that has a favourable and/or beneficial and/or improved (e.g. reduced)
30 dissolving time.

The present invention provides a composition suitable for use as a paint binder, or a component thereof, that has a favourable and/or beneficial and/or improved (e.g. reduced) time to reach a suitable viscosity level.
35

The present invention provides a composition suitable for use as a paint binder, or a component thereof, that yields a paint that has favourable and/or beneficial and/or improved smoothness (using BS3900-D5 parameters).

- 5 The present invention provides a composition suitable for use as a paint binder, or a component thereof, that yields a paint that has favourable and/or beneficial and/or improved adhesion using BS2409, BS3900-E6 parameters.

- 10 The present invention provides a composition suitable for use as a paint binder, or a component thereof, that yields a paint that has favourable and/or beneficial and/or improved hiding power.

- 15 The present invention provides a composition suitable for use as a paint binder, or a component thereof, that yields a paint that has favourable and/or beneficial and/or improved spreading rate.

- 20 The present invention provides a composition suitable for use as a paint binder, or a component thereof, that yields a paint that has favourable and/or beneficial and/or improved surface drying rate (as per BS3900-C2).

- The present invention provides a composition suitable for use as a paint binder, or a component thereof, that yields a paint that has favourable and/or beneficial and/or improved reflectivity (as per BS3900-D5).

- 25 The present invention provides a composition suitable for use as a paint binder, or a component thereof, that yields a paint that has favourable and/or improved and/or longer pot life.

- 30 The present invention provides a composition suitable for use as a paint binder, or a component thereof, that yields a paint that has favourable and/or beneficial and/or improved opacity on normal decorating surfaces.

- 35 The present invention provides a combination of a composition suitable for use as a paint binder, or a component thereof, and a water conditioning component that yields a paint that has favourable and/or beneficial and/or improved and/or extended pot life and produces an acceptable and stable paint when mixed with water samples of a wide range of pH levels –

such as from about pH 4.5 to about pH 12, such as from about pH 5 to about pH 12, such as from about pH 5.5 to about pH 11.5, such as about pH 5.5 or about pH 7.8 or about pH 11.5.

ADDITIONAL TEACHINGS

5

Typical paint products, in particular architectural paint products, comprise the following four main constituents:

- 10 1. A 'binder' which acts as an adhesive of itself and/or to other materials to the painted surface. The 'binder' component may also include small quantities of additives - for example additives that are used to reduce liquid foaming, or to inhibit mould growth.
2. 'Pigments' or colouring materials of natural and/or synthetic sources which are capable of reflecting light of particular hue to a typical viewer.
- 15 3. 'Fillers' or 'extenders' which typically are inert materials used to bulk out the paint product and/or modify the opacity of the binder and pigment.
- 20 4. A 'carrier' or 'fluid vehicle' - such as water, hydrocarbon or alcohol solvent, or mixtures thereof - in which the other materials are either dissolved or held in suspension. The carrier fluid, which may constitute up to 75% of the total paint product, will typically evaporate into the atmosphere on application leaving behind the dry paint film adhering to the surface.

In the paint binder composition of the present invention, constituent 1 is present. Optionally, constituent 2 may be present in the paint binder composition of the present invention or constituent 3 may be present in the paint binder composition of the present invention.
25 Optionally, constituent 2 may be present in the paint binder composition of the present invention and constituent 3 may be present in the paint binder composition of the present invention. A water conditioning component may also be present.

30 However, unlike such typical paint products, in the present invention constituent 4 (i.e. the fluid vehicle - typically water) - is added by the customer or end user.

The formulation of the present invention can cope with varying user mixing methods, tap water temperatures, local alkalinity and hardness.

The paint binder composition of the present invention comprises at least: a protein; a polysaccharide; an emulsifier; and a thickening ingredient. Together, the paint binder composition and the fluid vehicle (e.g. water) produce the resultant liquid paint.

- 5 Other paint ingredients/materials/components may be present in the paint binder composition – such as a water conditioning component and/or colourants.

In one aspect, a water conditioning component and/or a colourant may be added together or separately to a fluid vehicle, either before, during or after addition of the paint binder
10 composition to said fluid vehicle.

In a preferred aspect, the paint binder composition of the present invention comprises a water conditioning component and/or a colourant.

- 15 In a preferred aspect, the paint binder composition of the present invention comprises a water conditioning component and a colourant.

In a preferred aspect, the composition of the present invention suitable for use as a paint binder of the present invention comprises a polysaccharide; an emulsifier; a thickening
20 ingredient; and one or more of: one or more enhance slip agents, one or more additional adhesion agents, one or more antifoaming ingredients, one or more preservatives, biocides or fungicides (e.g. agents that prevent mould), one or more activators, one or more colourants, one or more fillers, one or more extenders, one or more water conditioning agents.

25 A preferred composition of the present invention suitable for use as a paint binder of the present invention comprises the following ingredients/components (% values shown are with respect to these four components only):

- 30 80-90% by weight casein protein or other protein powder
5-10% by weight dextrin or other polysaccharide powder
2-5% by weight soy lecithin or other emulsifier
2-10% by weight cellulose fibres or other thickening ingredient

- 35 A preferred composition of the present invention suitable for use as a paint binder of the present invention comprises the following ingredients/components:

Component
Casein
Lecithin
Dextrin
Technocell (cellulose fibres)
Gum Arabic
Gum Tragacanth
CMC (carboxymethyl cellulose)
Bentonite
SMP
Zinc Oxide
Lime (calcium hydroxide)

For some embodiments, a preferred composition of the present invention suitable for use as a paint binder of the present invention comprises the following ingredients/components and in the following amounts:

5

Component	Amounts
Casein	10 to 20% - such as about 15%
Lecithin	0.2 to 1% - such as about 0.55%
Dextrin	0.5 to 2% - such as about 1.2%
Technocell	0.5 to 2% - such as about 1.2%
Gum Arabic	0.2 to 1% - such as about 0.55%
Gum Tragacanth	0.2 to 1% - such as about 0.55%
CMC	0.5 to 2% - such as about 1.25%
Bentonite	0.05 to 0.2% - such as about 0.15%
SMP	0.5 to 2% - such as about 1.2%
Zinc Oxide	0.5 to 2% - such as about 1.2%
Lime	1 to 5% - such as about 2.0%

For some embodiments, a preferred composition of the present invention suitable for use as a paint binder of the present invention comprises the following ingredients/components and in the following amounts:

10

Component	Amounts
Casein	about 15%
Lecithin	about 0.55%
Dextrin	about 1.2%
Technocell	about 1.2%
Gum Arabic	about 0.55%
Gum Tragacanth	about 0.55%
CMC	about 1.25%
Bentonite	about 0.15%
SMP	about 1.2%
Zinc Oxide	about 1.2%
Lime	about 2.0%

The filler/extender products are selected to provide opacity and durability to the finished product.

5 A water conditioning component may be included in the composition of the present invention suitable for use as a paint binder of the present invention. Such a component maintains performance against a wide range of variation in the hardness and alkalinity of the user supplied tap water.

10 In one aspect, the water conditioning component suitable for use with or in a paint binder composition comprises one or more of a Group I metal halide; a Group I metal carbonate; a degreaser; and a glucose-containing component.

In one preferred aspect, the degreaser is a sodium phosphate, such as trisodium phosphate.

15 In one aspect, the water conditioning component suitable for use with or in a paint binder composition comprises two or more of a Group I metal halide; a Group I metal carbonate; a degreaser; and a glucose-containing component.

In one preferred aspect, the degreaser is a sodium phosphate, such as trisodium phosphate.

20 In one aspect, the water conditioning component suitable for use with or in a paint binder composition comprises three or more of a Group I metal halide; a Group I metal carbonate; a degreaser; and a glucose-containing component.

25 In one preferred aspect, the degreaser is a sodium phosphate, such as trisodium phosphate.

In one aspect, the water conditioning component suitable for use with or in a paint binder composition comprises a Group I metal halide; a Group I metal carbonate; a degreaser; and a glucose-containing component.

30 In one preferred aspect, the degreaser is a sodium phosphate, such as trisodium phosphate.

An example of a preferred water conditioning component comprises one or more Group I metal halides.

35 A preferred example of such a preferred water conditioning component is wherein the % by weight of Group I metal halides in said water conditioning component is up to 50%.

A preferred example of a Group I metal halide is sodium chloride.

5 A preferred example of such a preferred water conditioning component is wherein the % by weight of sodium chloride in said water conditioning component is up to 50%.

An example of a preferred water conditioning component comprises one or more Group I metal carbonates.

10 A preferred example of such a preferred water conditioning component is wherein the % by weight of Group I metal carbonates in said water conditioning component is up to 50%.

A preferred example of a Group I metal carbonate is sodium carbonate.

15 A preferred example of such a preferred water conditioning component is wherein the % by weight of sodium carbonate in said water conditioning component is up to 50%.

An example of a preferred water conditioning component comprises one or more Group I metal phosphates.

20 A preferred example of such a preferred water conditioning component is wherein the % by weight of Group I metal phosphates in said water conditioning component is up to 50%.

A preferred example of a Group I metal phosphate is sodium phosphate.

25 A preferred example of such a preferred water conditioning component is wherein the % by weight of sodium phosphate in said water conditioning component is up to 50%.

30 An example of a preferred water conditioning component comprises one or more glucose containing components.

A preferred example of such a preferred water conditioning component is wherein the % by weight of glucose containing components in said in said water conditioning component is up to 50%.

35 In one preferred aspect, the glucose-containing component is a disaccharide.

A preferred example of a glucose containing component is sucrose.

A preferred example of such a preferred water conditioning component is wherein the % by weight of sucrose in said water conditioning component is up to 50%.

5

An example of a preferred water conditioning component comprises the following components: one or more Group I metal halides, one or more Group I metal carbonates, one or more Group I metal phosphates, and one or more glucose containing components.

10

An example of a preferred water conditioning component comprises the following components: one or more Group I metal halides, one or more Group I metal carbonates, one or more Group I metal phosphates, and one or more glucose containing components, wherein the % by weight of Group I metal halides in said water conditioning component is up to 50%, wherein the % by weight of Group I metal carbonates in said water conditioning component is up to 50%, wherein the % by weight of Group I metal phosphates in said water conditioning component is up to 50%, wherein the % by weight of glucose containing components in said in said water conditioning component is up to 50%.

15

20

A preferred example of a preferred water conditioning component comprises the following components: sodium chloride, sodium carbonate, sodium phosphate and sucrose.

25

A preferred example of a preferred water conditioning component comprises the following components: sodium chloride, sodium carbonate, sodium phosphate and sucrose, wherein the % by weight of sodium chloride in said water conditioning component is up to 50%, wherein the % by weight of sodium carbonate in said water conditioning component is up to 50%, wherein the % by weight of sodium phosphate in said water conditioning component is up to 50%, wherein the % by weight of sucrose in said water conditioning component is up to 50%.

30

A preferred example of a water conditioning component comprises the following ingredients/components:

Component
Salt
Sugar
Soda
sodium phosphate

A preferred example of a water conditioning component comprises the following ingredients/components and in the following amounts:

Component	Amount
Salt	1 to 2% - such as about 1.6%
Sugar	0.3 to 1.2% % - such as about 0.7%
Soda	1 to 2% - such as about 1.6%
sodium phosphate	0.1 to 0.4% - such as about 0.25%

5 A preferred example of a water conditioning component comprises the following ingredients/components and in the following amounts:

Component	Amount
Salt	about 1.6%
Sugar	about 0.7%
Soda	about 1.6%
sodium phosphate	about 0.25%

10 Paint ingredients, such as colourant and/or water conditioning component materials, may be added to the water just before, during or after, as well as any combination thereof, addition of the paint binder composition of the present invention to the fluid vehicle (e.g. water).

Aspects of the present invention are now presented by way of numbered paragraphs.

15 1. A composition suitable for use as a paint binder, said composition comprising:

- a) a protein;
- b) a polysaccharide;
- c) an emulsifier;
- d) a thickening ingredient;

20 wherein said composition in a dry state has a homogeneous particle size of less than about 100 μm , preferably less than about 90 μm , preferably less than about 80 μm , preferably about 75 μm . In some embodiments it is preferred that the homogeneous particle size of the composition suitable for use as a paint binder is between about 75 μm to about 100 μm .

25 2. A composition according to paragraph 1 wherein said protein is a protein derived from milk.

3. A composition according to paragraph 1 or paragraph 2 wherein said protein is casein, such as acid casein.

4. A composition according to any one of paragraphs 1 to 3 wherein said polysaccharide is a glucose polymer.
- 5 5. A composition according to any one of paragraphs 1 to 4 wherein said polysaccharide is dextrin.
6. A composition according to any one of paragraphs 1 to 5 wherein said emulsifier comprises at least one phospholipid moiety.
- 10 7. A composition according to any one of paragraphs 1 to 6 wherein said emulsifier is lecithin, preferably soy lecithin.
- 8a. A composition according to any one of paragraphs 1 to 7 wherein said composition further comprises a colourant.
- 15 8b. A paint according to paragraph 8a wherein said colourant is a pigment.
- 8c. A paint according to paragraph 8a or 8b wherein said colourant is a granulated pigment.
- 20 8d. A paint according to paragraph 8a, 8b or 8c wherein said colourant is an organic or inorganic pigment.
- 8e. A paint according to paragraph 8a, 8b, 8c or 8d wherein said colourant is selected from the list: ochres, oxides, dioxides, umbers, vegetable dyes and naturally occurring earth pigments.
- 25 9. A composition according to any one of paragraphs 1 to 8 wherein said thickening ingredient is a fibrous material.
- 30 10. A composition according to any one of paragraphs 1 to 9 wherein said thickening ingredient is a carbohydrate-based fibrous material.
- 35 11. A composition according to any one of paragraphs 1 to 10 wherein said thickening ingredient is a glucose polymer.

12. A composition according to any one of paragraphs 1 to 11 wherein said thickening ingredient is a cellulosic material.
13. A composition according to any one of paragraphs 1 to 12 wherein said thickening
5 ingredient is cellulose.
14. A composition according to any one of paragraphs 1 to 13 wherein said composition further comprises a preservative.
- 10 15. A composition according to paragraph 14 wherein said preservative is a fungicidal preservative.
16. A composition according to paragraph 14 or paragraph 15, wherein said preservative is independently selected from the list: zinc oxide, potassium sorbate or borax.
15
17. A composition according to any one of paragraphs 1 to 16 wherein said composition further comprises an antifoaming ingredient.
18. A composition according to paragraph 17 wherein said antifoaming ingredient is clay,
20 such as bentonite.
19. A composition according to any one of paragraphs 1 to 18 wherein said composition further comprises a water conditioning component.
- 25 20. A method of manufacturing the composition of any one paragraphs 1 to 19, comprising subjecting components of the composition to a shearing process.
21. A method according to paragraph 20, comprising subjecting components of the composition to a shearing process driven by electrical or mechanical means.
30
22. A method according to paragraph 20 or paragraph 21, comprising subjecting components of the composition to a shearing process using an apparatus with blades.
23. A method according to any one of paragraphs 20 to 22, comprising subjecting
35 components of the composition to a shearing process using an apparatus comprising horizontal and vertical blades.

24. A method according to any one of paragraphs 20 to 23, comprising subjecting components of the composition to a shearing process using an apparatus comprising horizontal and vertical blades, wherein said vertical blades are fluted.
- 5 25. A method according to any one of paragraphs 20 to 24, comprising subjecting components of the composition to a shearing process using an apparatus comprising horizontal and vertical blades, wherein said vertical blades contain spiral fluting.
- 10 26. A method according to any one of paragraphs 20 to 25, comprising subjecting components of the composition to a shearing process using an apparatus comprising horizontal and vertical blades, wherein said vertical blades contain spiral fluting and are located away from the horizontal blades.
- 15 27. A method according to any one of paragraphs 20 to 26, comprising subjecting components of the composition to a shearing process using an apparatus comprising horizontal and vertical blades, wherein said vertical blades contain spiral fluting and are located at one end of a vertical cylindrical blade shaft.
- 20 28. A method according to any one of paragraphs 20 to 27, comprising subjecting components of the composition to a shearing process using an apparatus comprising horizontal and vertical blades, wherein said vertical blades contain spiral fluting and are located at one end of a vertical cylindrical blade shaft and further wherein said horizontal blades are rotatable in the horizontal plane about said vertical cylindrical blade shaft.
- 25 29. A method according to any one of paragraphs 20 to 28, comprising subjecting components of the composition to a shearing process using the apparatus (1) as shown in Figure 1.
- 30 30. A composition obtainable from the method according to any one of paragraphs 20 to 29.
31. A paint comprising the composition of any one of paragraphs 1 to 19 or a composition of paragraph 30.
- 35 32. A paint according to paragraph 31, wherein said composition is present in the paint in an amount from about 14.45% to about 38.2% by weight.

33. A paint according to paragraph 31 or paragraph 32 wherein said paint is in a dry powder state.
34. A paint according to any one of paragraphs 31 to 33 wherein said paint further comprises
5 one or more of:
a colourant;
an activator;
a filler mixture.
- 10 35. A paint according to paragraph 34 wherein a colourant is present and wherein said colourant is a pigment, preferably a granulated pigment.
36. A paint according to paragraph 34 or paragraph 35 wherein a colourant is present and wherein said colourant is an organic or inorganic pigment.
15
37. A paint according to any one of paragraphs 34 to 36 wherein a colourant is present and wherein said colourant is independently selected from the list: ochres, oxides, dioxides, umbers, vegetable dyes and naturally occurring earth pigments.
- 20 38. A paint according to any one of paragraphs 34 to 37 wherein a colourant is present and wherein said colourant is present in an amount from about 0.5% to about 20% by weight.
39. A paint according to any one of paragraphs 34 to 38 wherein an activator is present and wherein said activator is a binder activating material.
25
40. A paint according to any one of paragraphs 34 to 39 wherein an activator is present and wherein said activator is independently selected from the list: calcium hydroxide, ammonium carbonate and borax.
- 30 41. A paint according to any one of the paragraphs 34 to 40 wherein an activator is present and wherein said activator is present in an amount from about 1% to about 10% by weight.
42. A paint according to any one of paragraphs 34 to 41 wherein a filler mixture is present and wherein said filler mixture is a mineral filler mixture.
35

43. A paint according to any one of paragraphs 34 to 42 wherein a filler mixture is present and wherein said filler mixture is independently selected from the list: kaolin, magnesium silicate and calcium carbonate.
- 5 44. A paint according to any one of paragraphs 34 to 43 wherein a filler mixture is present and wherein said filler mixture is present in an amount from about 50% to about 70% by weight.
- 10 45. A method of manufacturing a paint of any one of paragraphs 31 to 44 comprising subjecting said components to further iterations of a shearing process of paragraphs 20 to 32.
- 15 46. A method of manufacturing a paint of any one of paragraphs 31 to 44 comprising pre-mixing said components for a period of between 10 to 20 minutes and further subjecting said components to further iterations of a shearing process of paragraphs 20 to 29.
47. A paint obtainable according to the method of paragraph 45 or paragraph 46.
- 20 48. A liquid paint comprising the paint of any one of paragraphs 31 to 44 or a paint according to paragraph 47 and a fluid vehicle.
49. A liquid paint according paragraph 48 wherein said fluid vehicle is an aqueous solvent, preferably water.
- 25 50. A liquid paint according to paragraph 48 or paragraph 49, wherein said liquid paint further comprises one or more fluid paint excipients, additional diluents or additional carriers.
- 30 51. A liquid paint according paragraph 49 or paragraph 50 wherein said excipient, diluent or carrier is independently selected from the list: water, wax emulsions, beeswax emulsion, gums, glues, linseed oil, safflower oil and tung oil, or combinations thereof.
- 35 52. A method of manufacturing a liquid paint of any one of paragraphs 48 to 51, said method comprising mixing the components of a paint according to any one of paragraphs 31 to 44 or paragraph 47 with one or more paint excipients, diluents or carriers according paragraphs 49 to 51.
53. A liquid paint obtainable according to the method of paragraph 52.

54. A method of applying a liquid paint according to any one of paragraphs 48 to 51 or paragraph 53 to a surface.
- 5 55. Use of the composition of any one of paragraphs 1 to 19 or composition of paragraph 31 to reduce the levels of volatile organic compounds in a paint, preferably the paint of any one of paragraphs 31 to 44 or paragraph 47.
- 10 56. Use of the composition of any one of paragraphs 1 to 19 or composition of paragraph 31 to reduce the levels of volatile organic compounds in a liquid paint, preferably the paint of any one of paragraphs 48 to 51 or paragraph 53.
- 15 57. A composition suitable for use as a paint binder substantially as described herein and with reference to the Examples.
58. A paint substantially as described herein and with reference to the Examples.
59. A liquid paint substantially as described herein and with reference to the Examples.
- 20 60. A method substantially as described herein and with reference to the Examples.
61. A method substantially as described herein and with reference to the drawings.

Additional aspects of the present invention are now presented by way of numbered
25 paragraphs. These aspects are to be read in conjunction with the aforementioned aspects of the present invention.

- 30 1. The consistent, homogeneous and uniform particle production of a dry powder paint binder from milk and plant proteins with other natural materials through a shearing process driven by electrical, mechanical or other means.
2. Production of a paint binder composition according to paragraph 1 further comprising mineral filler, colouring pigments and other materials to produce a dry powder paint.
- 35 3. Production of a paint binder and powder paint composition according to paragraph 1 and 2 further comprising a preservative and fungicide.

4. Production of a paint binder and powder paint composition according to paragraph 3 wherein the preservative is selected from zinc oxide and potassium sorbate and borax.
5. Production of a paint binder and powder paint composition according to any one of paragraphs 1 to 4 further comprising an antifoaming ingredient.
6. Production of a paint binder and powder paint composition according to paragraph 5 wherein the antifoaming ingredient is selected from silica sand.
- 10 7. Production of a paint binder and powder paint composition according to any one of paragraphs 1 to 6 further comprising a thickening ingredient.
8. Production of a paint binder and powder paint composition according to paragraph 7 wherein the thickening ingredient is selected from cellulose fibres and cellulose material.
- 15 9. Production of a paint binder and powder paint composition according to any one of paragraphs 1 to 6 further comprising a water conditioning component.
10. Production of a paint binder and powder paint composition according to paragraph 7 wherein the water conditioning component is a polysaccharide substance such as dextrin.
- 20 11. Production of a dry powder paint comprising a paint binder composition according to any one of paragraphs 1 to 8 and further comprising a filler mixture.
- 25 12. Production of a dry powder paint according to paragraph 9 wherein the filler mixture is selected from kaolin, magnesium silicate and calcium carbonate.
13. Production of a dry powder paint comprising a paint binder composition according to any one of paragraphs 1 to 10 and further comprising an activator.
- 30 14. Production of a dry powder paint according to paragraph 11 wherein the activator is selected from calcium hydroxide, ammonium carbonate and borax.
15. Production of a dry powder paint comprising a paint binder composition according to any one of paragraphs 1 to 12 and further comprising one or more pigments.
- 35

16. Production of a dry powder paint according to paragraph 14 wherein the pigment(s) is(are) selected from organic and inorganic pigments, ochres, oxides, dioxides, umbers, vegetable dyes and other naturally occurring earth pigments.
- 5 17. A dry powder paint according to paragraphs 2 to 14 wherein 15 to about 30% of said dry-powder paint is binder compound.
18. A dry powder paint according to paragraph 2 to 14 wherein 50 to about 70% of said dry powder paint is filler materials.
- 10 19. A dry powder paint according to paragraphs 2 to 14 wherein 0.5 to about 20% of said dry powder paint is pigment material.
20. A dry powder paint according to paragraphs 2 to 14 wherein 1 to about 10% of said dry powder paint is activating material.
- 15 21. A dry powder paint according to paragraphs 2-14 wherein 0.5 to about 2% of said dry powder paint is preservative material.
- 20 22. A dry powder paint according to paragraph 2-14 wherein 0.05 to about 1% of said dry powder paint is a water conditioning component, such as a dispersant material.
23. A method of manufacturing said specific paint binder composition for use in manufacturing the said dry powder paint comprising the steps of: providing casein protein, providing soy lecithin, providing dextrin; providing cellulose fibres and combining and subsequently shearing particles to a fineness of between 60-80 microns through a horizontal high speed shearing operation of not less than 30 and not more than 300 seconds duration.
- 25 24. A method of manufacturing said dry powder paint comprising the steps of: providing said specific binder compound; providing filler mixture; providing pigment; providing preservative; providing anti-foaming materials; providing water conditioning component (such as a dispersant); providing activator and processing thoroughly in a vortex creating horizontal cutter for a period of not less than 60 and not more than 300 seconds whereas the finished material will pass through a mesh containing 200 holes per square inch.
- 30 25. A liquid paint comprising the paint binder composition and dry-powder paint according to any paragraphs 1 to 23 and one or more liquids.
- 35

26. A liquid paint according to paragraph 23, wherein the liquid(s) is (are) selected from: water; beeswax emulsion; other wax emulsions; gums; glues; linseed oil; safflower oil; sunflower oil; tung oil.

5

27. A method comprising the mixing procedure of paint binder and dry powder paint compositions produced according to paragraphs 2-23 with one or more liquids.

10

28. A method comprising applying the liquid paint according to paragraphs 23 and 24 to a surface.

29. An architectural or decorative coating binder composition comprising casein or other protein, soy lecithin or other emulsifier, polysaccharide such as dextrin and cellulose fibres or other thickener.

15

30. A liquid architectural or decorative coating comprising an architectural or decorative coating binder composition according to paragraph 29 and one or more liquids.

20

31. A method comprising applying the liquid architectural or decorative coating according to paragraph 30 to a surface.

32. A dry powder paint according to any one of paragraphs 11 to 23 where in the dry powder paint further comprises a granulated pigment which may also be known as a 'stir-in' pigment.

25

33. A dry powder paint according to paragraph 32 wherein the granulated pigment is included from a range of differently coloured pigments within the dry powder paint in proportions as to produce a predetermined colour or range of colours.

30

34. A liquid paint as described in paragraphs 24 to 33 wherein such granulated pigments, or 'stir-in' pigments are first dissolved in the mixing water or liquid to be combined with said dry powder paint in proportions as to produce a pre-determined colour or range of colours.

35

Additional aspects of the present invention are now presented by way of numbered paragraphs. These aspects are to be read in conjunction with the aforementioned aspects of the present invention.

1. A paint binder composition comprising casein or other proteins, soy lecithin, dextrin or other polysaccharides and cellulose fibres.
- 5 2. A paint binder composition according to paragraph 1 further comprising a preservative and fungicide.
3. A paint binder composition according to paragraph 2 wherein the preservative and fungicide is selected from zinc oxide and potassium sorbate and borax.
- 10 4. A paint binder composition according to any one of paragraphs 1 to 3 further comprising an antifoaming ingredient.
5. A paint binder composition according to paragraph 4 wherein said antifoaming ingredient is silica sand.
- 15 6. A paint binder composition according to any one of paragraphs 1 to 5 further comprising a water conditioning component (such as a dispersant).
7. A paint binder composition according to paragraph 6 wherein the water conditioning component (such as a dispersant) is a polysaccharide substance.
- 20 8. A method of preparing a paint binder composition said method comprising mixing casein protein, soy lecithin, dextrin and cellulose fibres.
- 25 9. A method according to paragraph 8 wherein the paint binder composition is a paint binder composition as defined in any one of paragraphs 2 to 7.
10. A dry-powder paint comprising the paint binder composition according to any one of paragraphs 1 to 7 and a filler mixture.
- 30 11. A dry-powder paint according to paragraph 10 wherein the filler mixture is selected from kaolin, magnesium silicate, and calcium carbonate.
12. A dry-powder paint according to paragraph 10 or paragraph 11 further comprising an activator material selected from calcium hydroxide, ammonium carbonate and borax.
- 35

13. A dry-powder paint according to any one of paragraphs 10 to 12 wherein the dry-powder paint further comprises a pigment.
14. A dry-powder paint according to paragraph 13 wherein the pigment is selected from organic and inorganic pigments, ochres, oxides, dioxides, umbers, vegetable dyes and other naturally occurring earth pigments.
15. A dry-powder paint according to any one of paragraphs 10 to 14 wherein 15 to 30% of said dry-powder paint is the paint binder composition.
16. A dry-powder paint according to any one of paragraphs 10 to 15 wherein 50 to 70% of said dry-powder paint is filler material.
17. A dry-powder paint according to any one of paragraphs 10 to 16 wherein the dry-powder paint comprises pigment material and wherein 0.5 to 20% of said dry-powder paint is pigment material.
18. A dry-powder paint according to any one of paragraphs 10 to 17 wherein the dry-powder paint comprises preservative material and wherein 0.5 to 2% of said dry-powder paint is preservative material.
19. A dry-powder paint according to any one of paragraphs 10 to 18 wherein the dry-powder paint comprises water conditioning component (such as a dispersant material) and wherein 0.05% to 1% of said dry-powder paint is water conditioning component (such as a dispersant material).
20. A method of preparing a dry-powder paint comprising combining the paint binder composition according to any one of paragraphs 1 to 7 with a filler mixture.
21. A method according to paragraph 20 wherein the dry-powder paint is the dry-powder paint according to any one of paragraphs 10 to 19.
22. A method according to paragraph 20 or paragraph 21 comprising the steps of: providing said paint binder composition, filler mixture, pigment, preservative, anti-foaming materials and water conditioning component (such as a dispersant); pre-mixing same thoroughly for a period of not less than 10 and not more than 20 minutes; and subsequently grinding to an

overall fineness so that the finished material is capable of passing through a mesh containing 200 holes per square inch.

23. A liquid paint comprising the paint binder composition according to any one of paragraphs 1 to 7 or the dry-powder paint according to any one of paragraphs 10 to 19; and one or more liquids.

24. A liquid paint according to paragraph 23 wherein the liquid(s) is(are) selected from water; beeswax emulsion; other wax emulsions; gums; glues; linseed oil; safflower oil; and tung oil.

25. A method of preparing a liquid paint as defined in paragraph 23 or paragraph 24 said method comprising mixing the dry-powder paint according to any one of paragraphs 10 to 19 with one or more liquids.

26. A method comprising applying the liquid paint according to paragraph 23 or paragraph 24 to a surface.

27. An architectural or decorative coating binder composition comprising casein or other protein, soy lecithin or other emulsifier, polysaccharide such as dextrin and cellulose fibres or other thickener.

28. A liquid architectural or decorative coating comprising an architectural or decorative coating binder composition according to paragraph 27 and one or more liquids.

29. A method comprising applying the liquid architectural or decorative coating according to paragraph 28 to a surface.

30. A dry-powder paint according to any one of paragraphs 10 to 22 wherein the dry-powder paint further comprises a granulated pigment which may also be known as a 'stir-in' pigment.

31. A dry-powder paint according to paragraph 30 wherein the granulated pigment is included from a range of differently coloured pigments within the dry-powder paint in proportions as to produce a pre-determined colour or range of colours.

32. A liquid paint as described in paragraphs 23 to 29 wherein such granulated pigments, or 'stir-in' pigments are first dissolved in the mixing water or liquid to be combined with said dry-powder paint in proportions as to produce a pre-determined colour or range of colours.

5 Additional aspects of the present invention are now presented by way of numbered paragraphs. These aspects are to be read in conjunction with the aforementioned aspects of the present invention.

1. A composition suitable for use as a paint binder, said composition comprising:

- 10 a) casein;
 b) dextrin;
 c) an emulsifier; and
 d) a glucose polymer;
 wherein said composition in a dry state has a homogeneous particle size of less than
15 about 100 μm .

2. A composition according to paragraph 1 wherein said glucose polymer is a cellulosic material.

20 3. A composition according to paragraph 1 or paragraph 2 wherein said glucose polymer is cellulose.

4. A composition according to any one of paragraphs 1 to 3 wherein said emulsifier is lecithin.

25 5. A composition according to any one of paragraphs 1 to 4 wherein said composition further comprises a water conditioning component.

30 6. A composition according to any one of paragraphs 1 to 5 wherein said composition further comprises a colourant.

7. A method of manufacturing the composition of any one paragraphs 1 to 6, comprising subjecting the components of the composition to a shearing process.

35 8. A method of manufacturing the composition of any one paragraphs 1 to 6, comprising subjecting the components of the composition to a rotary shearing process.

9. A paint comprising the composition of any one of paragraphs 1 to 6 or a composition obtainable from the method according to paragraph 7 or paragraph 8.

5 10. A liquid paint wherein said liquid comprises a paint according to paragraph 9 and a fluid vehicle.

11. A liquid paint according paragraph 10 wherein said fluid vehicle is an aqueous solvent.

10 12. A liquid paint according paragraph 10 or paragraph 11 wherein said fluid vehicle is water.

13. A coloured liquid paint obtained from mixing the composition of any one of paragraphs 1 to 6 or a composition obtainable from the method according to paragraph 7 or paragraph 8 with a fluid vehicle; wherein the colour of the liquid paint is at least predominantly due to a colourant present in said composition.

15 14. A coloured liquid paint obtained from mixing the composition of any one of paragraphs 1 to 6 or a composition obtainable from the method according to paragraph 7 or paragraph 8 with a fluid vehicle; wherein the colour of the liquid paint is in part or totally due to a colourant added to said fluid vehicle, said colourant being distinct from said composition.

20 Additional aspects of the present invention are now presented by way of numbered paragraphs. These aspects are to be read in conjunction with the aforementioned aspects of the present invention.

25 1. A composition suitable for use as a paint binder, said composition comprising: a) a protein; b) a polysaccharide; c) an emulsifier; and d) a thickening ingredient; and a water conditioning component; wherein said composition in a dry state has a homogeneous particle size of less than about 100 μm .

30 2. A composition suitable for use as a paint binder, said composition comprising: a) a protein; b) a polysaccharide; c) an emulsifier; and d) a thickening ingredient; and a water conditioning component; wherein said composition in a dry state has a homogeneous particle size of less than about 100 μm ; and wherein said composition or at least a part thereof is prepared by subjecting components of the composition to a shearing process.

35 3. A composition suitable for use as a paint binder, said composition comprising: a) a protein; b) a polysaccharide; c) an emulsifier; and d) a thickening ingredient; and a water

conditioning component; wherein said composition in a dry state has a homogeneous particle size of less than about 100 μm ; wherein said composition or at least a part thereof is prepared by subjecting components of the composition to a shearing process; and wherein said shearing process uses an apparatus comprising horizontal and vertical blades, wherein
5 said vertical blades contain spiral fluting and are located at one end of a vertical cylindrical blade shaft and further wherein said horizontal blades are rotatable in the horizontal plane about said vertical cylindrical blade shaft.

4. A paint comprising the composition of any one of paragraphs 1 to 3.

10 5. A paint according to paragraph 4 also comprising colorant.

6. A paint according to paragraph 4 or paragraph 5 wherein said paint is a liquid paint.

15 7. A paint according to paragraph 6 wherein said paint is an aqueous based paint.

The present invention will now be described by way of example.

EXAMPLES

20 In the following examples, references to "rotary mix and shear" "rotary mix/shear" refer to the use of the shearing process of the present invention.

In the following examples, references to "water dispersant" refer to the water conditioning
25 component of the present invention.

Introduction

Essentially, the paint binder composition of the present invention is prepared by a process
30 that includes the following steps:

- Obtain the ingredients
- Weigh out the required amounts of the ingredients
- Mix and shear cut the ingredients to a fine powder for use to prepare a paint
- Bag and seal the fine powder

Example 1 - Compositions

In a specific example, the paint binder composition of the present invention comprises the ingredients presented in the Table below:

5

Component	Total	Name	Purpose	Source
Casein	15%	Acid Casein 90 mesh	Adhesion	Dairy producers, such as Univar, Nestle, Irish Dairy Board
Lecithin	0.55%	Soya Lecithin	Emulsifier	Thew Arnott
Dextrin	1.2%	Dextrin Starch Gum	Thickener	Thew Arnott
Technocell	1.2%	Cellulose Fibre	Thickener	CFF Gmbh
Gum Arabic	0.55%	Acacia Gum Powder	Adhesion	Thew Arnott
Gum Tragacanth	0.55%	Astralagus Gum	Adhesion	Thew Arnott
CMC	1.25%	Carboxy Methyl Cell.	Thickener	Bath Potters Supplies
Bentonite	0.15%	Montmorillonite	Enhance Slip	Bath Potters Supplies
SMP	1.2%	Skimmed Milk Pdr.	Defoamer	Dairy producers, such as Univar, Nestle, Irish Dairy Board
Zinc Oxide	1.2%	Zinc Oxide	Inhibit Mould Pigment	Suppliers, such as Colour Blaze
Lime	2.0%	Calcium Hydrate	Activator	Builders Merchants of various sources

% Finished Product 24.85%

A finished product refers to a complete paint binder composition of the present invention - comprising all of the components including the filler, binder, pigment and other ingredients - which is ready to be mixed with a fluid vehicle, such as tap water, to produce a liquid decorating paint product which can be applied by typical means.

The filler/extender products are selected to provide opacity and durability to the finished product.

15

Other clay powders, such as Earthenware, may be substituted for Polewhite where a darker paint colour is to be produced. Examples include:

Component	Total	Name	Purpose	Source
Polestar	25%	Calcined Kaolin	Opacity	Imerys
Polewhite/Other clays	13%	Kaolin	Durability	Imerys
Talc	13%	Magnesium Silicate	Slip/Durability	Richard Baker Harrison

% Finished Product 51%

5 A finished product refers to a complete paint binder composition of the present invention - comprising all of the components including the filler, binder, pigment and other ingredients - which is ready to be mixed with a fluid vehicle, such as tap water, to produce a liquid decorating paint product which can be applied by typical means.

10 A water conditioning component may be included. Such a component maintains performance against a wide range of variation in the hardness and alkalinity of the user supplied tap water. An example is:

Component	Total	Name	Purpose
Salt	1.6%	Sodium Chloride	Ionisation of water molecules
Sugar	0.7%	Sucrose	Ionisation of water molecules
Soda	1.6%	Sodium Carbonate	Water buffer
sodium phosphate	0.25%	Sodium Polyphosphate	Calcium Ion modification

% Finished Product 4.15%

15 A finished product refers to a complete paint binder composition of the present invention - comprising all of the components including the filler, binder, pigment and other ingredients - which is ready to be mixed with a fluid vehicle, such as tap water, to produce a liquid decorating paint product which can be applied by typical means.

20 Typically, the accumulated weight accounts for about 80% of the paint binder composition - herein referred to as the "bulk materials". The remaining amount (typically about 20%) may comprise pigments according to an individual colour formulation. Examples of a colour formulation are detailed below.

- The colour components are added to the bulk materials. The colour component may
25 comprise pigments selected from a wide range of, for example, ochres, oxides, siennas, earths and other colouring materials combined with a proportion of a

standard white pigment, Titanium Dioxide. Titanium Dioxide is also able to add opacity to the finished paint product.

- The colouring pigments may be sourced from a variety of suppliers according to need and availability, including Cornelissen, Gerstaecker, Colour Blaze, Brodie and Middleton.

Example 2 – Production Process

We discovered that in some instances some of the raw materials required for the production of the formulation of the present invention may not have the degree of fineness required to produce a satisfactory product for end customer use.

Therefore, for some aspects, we perform a pre-treatment step wherein the various particle sizes are all reduced to a fineness of 200 mesh (75 microns), or even finer. These pretreated ingredients are then mixed, optionally with colouring components. The pretreatment step provides an even more consistent colour finish to the paint.

Under previous operating procedures, coarse and fibrous components were ground and milled separately from those of a greasy and sticky nature. These sub-assemblies of raw materials were then brought together and mixed to produce the final coloured paint product. In a preferred aspect, as discussed herein, we have now found that a particle reduction technique using a shearing action – such as by use of a rotary knife – yields particles to an acceptable fineness. Also, in a single operation appropriate mixing of the components is achieved.

The production methodology may be as follows:

- Obtain individual raw materials, usually in moisture proof sacks of 25 kg.
- Bagged raw materials are stored in dry areas. Open bags of raw materials are placed in steel lidded containers for immediate use.
- The formulations of the present invention may be produced in ‘batches’ of any suitable weight, such as around 10 kg per batch.
- Before production of each batch, all of the raw materials which are common to every batch are weighed and checked on electronic scales with an accuracy of c.1 g
- All common materials are added to a container with the weights tared for each additional component.

- The colouring components (typically about 20%) are separately weighed in a separate colour preparation area and checked on electronic scales with an accuracy better than ± 1 g. This separation prevents colour contamination between batches.
- Materials for each batch of coloured paint are checked and added to a cleaned processing container for particle reduction down to an overall size of c.200 mesh. Preferably a rotary blade configuration is used, such as that discussed herein.
- A sealed lid is clamped to the top of the processing container and once electrical safety checks are complete and the timer set, the machine is started and processing commences.
- At the end of the designated processing period, the processing machine is stopped, either automatically or manually, and the material is allowed to settle. The lid is then unclamped and the mixed materials are then placed in a clean bulk container ready for packaging.
- Depending on the finished package weight, the paint binder formulation of the present invention is then dispensed from a bulk container such as a moisture-proof paper bag or other suitable container, which is check weighed and then heat sealed to prevent any moisture contamination.
- Sealed bags are then labelled with the paint colour and batch number. The packages are then moved for packaging in various outers according to weight and distribution channel.

Additional information is as follows:

- A resultant paint prepared by use of the paint binder composition of the present invention may be a paint product classified as an 'Architectural Paint for interior Walls and Ceilings'.
- It is produced for and sold to the end-customer as a pre-mixed and pre-coloured water-soluble dry powder with a fineness of around 200mesh (75 micron). The paint binder composition of the present invention is packaged immediately after manufacture into a moisture proof and heat sealed bag, which is then placed in outer packaging according to size and distribution outlet. .
- The paint binder composition of the present invention is currently produced in 1kg and 80 g (tester) pack sizes, in 64 colour variations as suitable for decorating purposes. Other larger sizes may also be manufactured.
- The paint binder composition of the present invention can be produced in a wide range of colours.

- Shortly before use, the paint binder composition of the present invention is added to and mixed in with tepid tap water provided by the customer/user.
- After mixing and a thickening period, the resultant paint can be applied as any other similar paint to surfaces with normal decorating tools, i.e. brushes, rollers, paint pads and spray systems of both the airless and HVLP types.

Example 3 – Shearing mechanism

A typical composition of the invention was prepared as follows (% values shown are with respect to these four components only):

80-90% by weight casein protein or other protein powder

5-10% by weight dextrin or other polysaccharide powder

2-5% by weight soy lecithin or other emulsifier

2-10% by weight cellulose fibres or other thickening ingredient

The above ingredients of the paint binder composition were weighed and placed in a lidded container containing modified horizontal cutting blades arranged in an 'isle of man' configuration (see apparatus (1)).

The apparatus may comprise 2 or 3 rotary blades which can be set 120 degrees apart and at various heights and separations.

Referring to Figure 1, the apparatus (1) is equipped with three rotary blades (5), (10) and (15) which are arranged 120 degrees apart and at various heights and separations along a vertical blade shaft (20). Each of the three rotary blades (5), (10) and (15) is fixed at one end at 90 degrees to the blade shaft (20). The blade shaft (20) also has a set of spiral fluting at one end (30). The apparatus (1) is contained within a suitable housing (not shown).

During operation, the rotary blades (5), (10) and (15) rotate in the horizontal plane about the blade shaft (20).

The mixture was subjected to a series of shearing processes using apparatus (1) for approximately 120 seconds or less or until all are intimately mixed and cut to a size of between 65-70 microns, which can pass through a mesh of 200 holes per square inch (200 mesh) resulting in an evenly coloured product.

Example 4 – Mixing and testing of binder and resulting paint

The following preparations were used:

- 5 Binder 'A' - Plate ground binder, no water addition
 Binder 'B' - Plate ground binder + water conditioner
 Binder 'C' - Fine ground binder, no water addition
 Binder 'D' - Fine ground binder + water conditioner
 Paint 'E' - Paint made with Binder 'A'
 10 Paint 'F' - Paint made with Binder 'B'
 Paint 'G' - Paint made with Binder 'C'
 Paint 'H' - Paint made with Binder 'D'

Formulation of Paint Binder Composition and Paint

15

A.

Binder Sample A binder and activator- Tumble Mixed and Plate Milled to c. 100 mesh.

	A by % (Mixed plate mill)
Acid Casein	60.3
Soy Lecithin	2.211
Dextrin	4.824
Cellulose Fibres	4.824
Acacia Gum	2.211
Astralagus Gum	2.211
Carboxyl Methyl Cellulose	5.025
Montmorillonite (Bentonite)	0.603
Skimmed Milk Powder	4.824
Zinc Oxide	4.824
Hydrated Lime	8.04
Total	99.90

20

B.

Binder Sample B inc water dispersant- Tumble Mixed and Plate Milled to c. 100 mesh

	B by % (mixed plate mill)
Acid Casein	51.75
Soy Lecithin	1.8975
Dextrin	4.14
Cellulose Fibres	4.14
Acacia Gum	1.8975
Astralagus Gum	1.8975
Carboxyl Methyl Cellulose	4.3125
Montmorillonite (Bentonite)	0.5175
Skimmed Milk Powder	4.14
Zinc Oxide	4.14
Hydrated Lime	6.9
Sodium Chloride	5.52
Sucrose	2.415
Sodium Carbonate	5.52
Sodium Polyphosphate	0.8625
Total	100.05

C.

Binder Sample C binder + activator- High Speed Rotary Mix and Shear to c.200 mesh.

	C by % (Rotary Mix/shear)
Acid Casein	60.3
Soy Lecithin	2.211
Dextrin	4.824
Cellulose Fibres	4.824
Acacia Gum	2.211
Astralagus Gum	2.211
Carboxyl Methyl Cellulose	5.025
Montmorillonite (Bentonite)	0.603
Skimmed Milk Powder	4.824
Zinc Oxide	4.824
Hydrated Lime	8.04
Total	99.90

D.

5 Binder Sample D inc water dispersant- High Speed Rotary Mix & Shear to c.200 mesh

	D by % (Rotary Mix/Shear)
Acid Casein	51.75
Soy Lecithin	1.8975
Dextrin	4.14
Cellulose Fibres	4.14
Acacia Gum	1.8975
Astralagus Gum	1.8975
Carboxyl Methyl Cellulose	4.3125
Montmorillonite (Bentonite)	0.5175
Skimmed Milk Powder	4.14
Zinc Oxide	4.14
Hydrated Lime	6.9
Sodium Chloride	5.52
Sucrose	2.415
Sodium Carbonate	5.52
Sodium Polyphosphate	0.8625
Total	100.05

E.

Paint Sample E - NO Water Dispersant Tumble Mixed and Plate Milled to c. 100 mesh

	E by % (mixed plate mill)
Acid Casein	15.6
Soy Lecithin	0.572
Dextrin	1.248
Cellulose Fibres	1.248
Acacia Gum	0.572
Astralagus Gum	0.572
Carboxy Methyl Cellulose	1.3
Montmorillonite (Bentonite)	0.156
Skimmed Milk Powder	1.248
Zinc Oxide	1.248
Hydrated Lime	2.08
Sodium Chloride	0
Sucrose	0
Sodium Carbonate	0
Sodium Polyphosphate	0
	0
Calcined Kaolin	26
Kaolin	13.52
Magnesium Silicate	13.52
Titanium Dioxide	20.8
Total	99.684

F.

Paint Sample F, inc Water Dispersant Tumble Mixed and Plate Milled to c. 100 mesh

	F by % (mixed plate mill)
Acid Casein	15
Soy Lecithin	0.55
Dextrin	1.2
Cellulose Fibres	1.2
Acacia Gum	0.55
Astralagus Gum	0.55
Carboxy Methyl Cellulose	1.25
Montmorillonite (Bentonite)	0.15
Skimmed Milk Powder	1.2
Zinc Oxide	1.2
Hydrated Lime	2
Sodium Chloride	1.6
Sucrose	0.7
Sodium Carbonate	1.6
Sodium Polyphosphate	0.25
Calcined Kaolin	25
Kaolin	13
Magnesium Silicate	13
Titanium Dioxide	20
Total	100

G.

Paint Sample G - NO Water Dispersant High Speed Rotary Mix & Shear to c.200 mesh

	G by % (Rotary Mix/shear)
Acid Casein	15.6
Soy Lecithin	0.572
Dextrin	1.248
Cellulose Fibres	1.248
Acacia Gum	0.572
Astragalus Gum	0.572
Carboxy Methyl Cellulose	1.3
Montmorillonite (Bentonite)	0.156
Skimmed Milk Powder	1.248
Zinc Oxide	1.248
Hydrated Lime	2.08
Sodium Chloride	0
Sucrose	0
Sodium Carbonate	0
Sodium Polyphosphate	0
	0
Calcined Kaolin	26
Kaolin	13.52
Magnesium Silicate	13.52
Titanium Dioxide	20.8
Total	99.684

H.

Paint Sample H, inc Water Dispersant High Speed Rotary Mix & Shear to c.200 mesh

	H by % (Rotary Mix/Shear)
Acid Casein	15
Soy Lecithin	0.55
Dextrin	1.2
Cellulose Fibres	1.2
Acacia Gum	0.55
Astralagus Gum	0.55
Carboxy Methyl Cellulose	1.25
Montmorillonite (Bentonite)	0.15
Skimmed Milk Powder	1.2
Zinc Oxide	1.2
Hydrated Lime	2
Sodium Chloride	1.6
Sucrose	0.7
Sodium Carbonate	1.6
Sodium Polyphosphate	0.25
Calcined Kaolin	25
Kaolin	13
Magnesium Silicate	13
Titanium Dioxide	20
Total	100

5 1. Binder Mixing & Testing

The following ratios were used in order to achieve the correct consistency.

Binder 'A' - 1: 3 Binder to Water

10 Binder 'B' - 1: 4.5 "

Binder 'C' - 1: 3 "

Binder 'D' - 1: 4.5 "

All components were mixed using a Kenwood mixer for 10 minutes. All four wet binders were applied onto painted board using a 200 micron wirewound KBar applicator and allowed to dry at 20°C for 5 days.

5 Smoothness

Binders 'B' & 'D' gave a smoother film.

Adhesion

10

Adhesion test (BS EN ISO 2409)

Binder 'A' - Poor, quite crumbly, Class 5

Binder 'B' - Excellent, Class 0

15 Binder 'D' - Excellent, Class 0

Binder D was better than binder C.

2. Paint Mixing and Useable Life

20

All four paints were mixed as follows:-

250 g Powder to 225 g Water (at approximately 25°C). Components were mixed using the Kenwood mixer for 5 minutes at speed '2', sides of container scraped down to incorporate all dried powder.

25

A further 150 g of water was added and mixed for 5 minutes. The sample was rested for 20 minutes.

30 Overall ratio – 1:1.5 Powder: Water

Qualitative Results

Paint 'E' - Quite creamy & aerated after mixing, still liquid after 20 minutes resting. After storing overnight in a sealed container the sample had solidified and was unusable.

35

Paint 'F' - Slightly thicker than 'E' after resting 20 minutes but very aerated. The sample was slightly thicker after overnight storage & was still useable.

5 Paint 'G' - Seemed to disperse quicker than the above products although lower viscosity after 20 minutes resting & aerated. Just useable after overnight storage.

Paint 'H' - Dispersed as quickly as above 'G' sample although very aerated liquid product. Still liquid after overnight storage.

10 Application

All paints were practically applied by medium pile roller onto unsealed plasterboard. Paint 'E' could not be over-coated due to the sample solidifying overnight. The remaining three paints were over-coated and assessed. Paints 'F' and 'H' gave good opacity in two coats with 'G' being almost total opaque.

15

Spread Rates:-

'E' - 9.1m²/l

'F' - 16.4m²/l

20 'G' - 12.8m²/l

'H' - 13.4m²/l

Contrast Ratio

25 The paints were applied onto a Leneta card using a 200 micron wirewound KBar applicator. The panels were dried overnight at 20°C and measured using a Sheen Opac Meter.

Paint Contrast Ratio

E 93.44

30 F 88.23

G 94.57

H 80.53

Example 5 - Water Dispersant Tests: Buffering capacity and inhibition of paint gellingObjectives

- 5 To identify if the addition of the water conditioning component to the paint binder composition and the resulting paint has the effect of:
- 10 • Maintaining the pH of the mixed paint at a sufficient level to inhibit mould growth on application of the wet paint and subsequent drying period, i.e. a pH range of 10.5-11.0
 - Maintaining the target pH level when the mixing water used is of the varying pH levels permitted in UK tap water i.e. pH 6-10 (test parameters pH 5.5 and 11.5)
 - 15 • Maintaining an acceptable wet pot life of the resulting paint by inhibiting the occurrence of gelling and solidification of the paint for a period long enough to permit typical application of a first and second coat of paint.

The following preparations were used:

20

Paint 'G' - Paint made with Binder 'C'

Paint 'H' - Paint made with Binder 'D'

Formulation of Paint Binder Composition and Paint

5 G.

Paint Sample G - NO Water Dispersant High Speed Rotary Mix & Shear to c.200 mesh

	G by % (Rotary Mix/shear)
Acid Casein	15.6
Soy Lecithin	0.572
Dextrin	1.248
Cellulose Fibres	1.248
Acacia Gum	0.572
Astragalus Gum	0.572
Carboxy Methyl Cellulose	1.3
Montmorillonite (Bentonite)	0.156
Skimmed Milk Powder	1.248
Zinc Oxide	1.248
Hydrated Lime	2.08
Sodium Chloride	0
Sucrose	0
Sodium Carbonate	0
Sodium Polyphosphate	0
	0
Calcined Kaolin	26
Kaolin	13.52
Magnesium Silicate	13.52
Titanium Dioxide	20.8
Total	99.684

H.

Paint Sample H, inc Water Dispersant High Speed Rotary Mix & Shear to c.200 mesh

5

	H by % (Rotary Mix/Shear)
Acid Casein	15
Soy Lecithin	0.55
Dextrin	1.2
Cellulose Fibres	1.2
Acacia Gum	0.55
Astralagus Gum	0.55
Carboxy Methyl Cellulose	1.25
Montmorillonite (Bentonite)	0.15
Skimmed Milk Powder	1.2
Zinc Oxide	1.2
Hydrated Lime	2
Sodium Chloride	1.6
Sucrose	0.7
Sodium Carbonate	1.6
Sodium Polyphosphate	0.25
Calcined Kaolin	25
Kaolin	13
Magnesium Silicate	13
Titanium Dioxide	20
Total	100

Procedure

10 Paint powder samples 'G' (without water conditioning component) and 'H' (with water conditioning component) were used. Each sample (100 g) was mixed with 150 ml of mixing water over a 5 minute period using an electric pedestal mixer with a 20 mm horizontal disc blade.

In each test, the mixing water used was at a temperature of 25°C.

Three samples of mixing water at different measured pH levels were used:

- (A) pH 7.8;
- (B) pH 5.5; and
- (C) pH 11.5.

5

Two pH meters were used to take readings: A RaHs PH-009 and a Techpel PH-703. Both meters were calibrated with a pH 7.00 buffer solution.

10 After the initial mixing period of 5 minutes, pH readings were taken on each sample at intervals of 5, 15, 30 and 60 minutes.

Following the 60 minute reading, a drawdown test of 200 micron thickness was made on a black and white plastic coated Lanata test chart.

15

After 24 hours, each sample was checked again for viscosity and a second drawdown test performance of 200 micron.

20 It was found that all mixes using sample 'G' (without water conditioner) had gelled and thickened after 24 hours to the point where a drawdown test was not possible.

Test Conclusions

25 The addition of the water conditioning component has a significant effect in inhibiting gelling and thereby extending the usable pot life of the paint (Table 1).

The water conditioning component also has a 'buffering' effect which reduces the effect of varying pH levels of the tap water used for mixing the paint product. Here, see Figure 2, Figure 3 and Figure 4.

30

The use of the water conditioning component means the pH level of the resulting paint is contained within boundaries which are known to inhibit the growth of mould and fungus.

Table 1 - Effect of water conditioning component on inhibition of gelling of paint at various mixing water pH levels.

5

Water Additive Test	Mixing water pH	Sample 'G' viscosity and drawdown test after 60 mins	Sample 'H' viscosity and drawdown test after 60 mins
(A)	7.8	unusable	Liquid - usable
(B)	5.5	virtually unusable	Liquid - usable
(C)	11.5	unusable	Liquid - usable

Example 6 – Data Analysis

Figures 5-8

10

Figure 5 is a photographic image of paint sample E of reflected light. Figure 6 is a photographic image of paint sample H of reflected light. Figure 7 is a photographic image of paint sample E of reflected light. Figure 8 is a photographic image of paint sample H of reflected light.

15

The results shown in Figures 5 to 8 illustrate the beneficial results from the present invention. The shearing process yields a significant reduction in particle agglomeration. There is a significant reduction in pinholing in wet sample mixes of paints made according to the present invention.

20

Example 7 - Additional Studies

We found that when using a mixing process different to the preferred shearing process described herein we encountered occasional problems. For example, when using a rotary mixer to combine absorbent minerals and greasy materials for 10 mins and then passing the dry mixture through a plate mill in order to reduce particle sizes, the results were reasonably successful as a repetitive processing method (the resulting fineness of grind is between 90 and 120 mesh). However in certain studies we found that depending on the drying power of the pigments used in a particular paint colour, the plate mills may jam up and 'bind' repeatedly with quantities of the 'fatter' organic materials such as casein, soy lecithin and

30

greasier pigments such as titanium dioxide. To overcome this jamming problem the binder components, casein and gums, were separately processed in small quantities using domestic food processors with horizontal cutting blades. For small quantities, this is a relatively fast procedure but does not necessarily produce a uniform effect because heavier particles settle and remain below the lower blade.

5

In some embodiments we have found that at temperatures of around 60°C the protein materials (casein) are damaged to the point where the resultant paint will not mix to produce an acceptable product.

10

Example 8 - Summary of Results

Compared to the binder composition A, the binders of the present invention (binders C and D) performed better. Compared to the paint comprising binder composition A (paint E), paints comprising the binders of the present invention (paints G and H) performed better. Binder sample D yields very good adhesion and water conditioning/buffering properties. Paint sample H has very good paint properties.

15

Figures 5 to 8 illustrate the beneficial results from the present invention. The shearing process yields a significant reduction in particle agglomeration. There is a significant reduction in pinholing in wet sample mixes of paints made according to the present invention.

20

All references, including publications, patent applications, and patents, cited herein are hereby incorporated by reference in their entirety and to the same extent as if each reference were individually and specifically indicated to be incorporated by reference and were set forth in its entirety herein (to the maximum extent permitted by law). All headings and sub-headings are used herein for convenience only and should not be construed as limiting the invention in any way. The use of any and all examples, or exemplary language (e.g., "such as") provided herein, is intended merely to better illuminate the invention and does not pose a limitation on the scope of the invention unless otherwise claimed. No language in the specification should be construed as indicating any non-claimed element as essential to the practice of the invention. The citation and incorporation of patent documents herein is done for convenience only and does not reflect any view of the validity, patentability, and/or enforceability of such patent documents. This invention includes all modifications and equivalents of the subject matter recited in the claims appended hereto as permitted by applicable law.

25

30

35

CLAIMS

1. A composition suitable for use as a paint binder, said composition comprising:
- 5 a) a protein;
 b) a polysaccharide;
 c) an emulsifier; and
 d) a thickening ingredient;
- 10 wherein said composition in a dry state has a homogeneous particle size of less than about 100 μm .
2. A composition according to claim 1 wherein said protein is casein.
- 15 3. A composition according to claim 1 or claim 2 wherein said polysaccharide is dextrin.
4. A composition according to any one of claims 1 to 3 wherein said emulsifier is lecithin.
5. A composition according to any one of claims 1 to 4 wherein said thickening ingredient is
20 cellulose.
6. A composition according to any one of claims 1 to 5 wherein said composition further comprises a water conditioning component.
- 25 7. A composition according to any one of claims 1 to 6 wherein said composition further comprises a colourant.
8. A method of manufacturing the composition of any one claims 1 to 7, comprising
30 subjecting components of the composition to a shearing process.
9. A method according to claim 8, comprising subjecting components of the composition to a shearing process using an apparatus comprising horizontal and vertical blades, wherein said vertical blades contain spiral fluting and are located at one end of a vertical cylindrical blade shaft and further wherein said horizontal blades are rotatable in the horizontal plane about
35 said vertical cylindrical blade shaft.

10. A paint comprising the composition of any one of claims 1 to 7 or a composition obtainable from the method according to claim 8 or claim 9.

5 11. A liquid paint wherein said liquid comprises a paint according to claim 10 and a fluid vehicle.

12. A liquid paint according claim 11 wherein said fluid vehicle is an aqueous solvent.

10 13. A liquid paint according claim 11 or claim 12 wherein said fluid vehicle is water.

14. A coloured liquid paint obtained from mixing the composition of any one of claims 1 to 7 or a composition obtainable from the method according to claim 8 or claim 9 with a fluid vehicle; wherein the colour of the liquid paint is predominantly due to a colourant present in said composition.

15 15. A coloured liquid paint obtained from mixing the composition of any one of claims 1 to 7 or a composition obtainable from the method according to claim 8 or claim 9 with a fluid vehicle; wherein the colour of the liquid paint is solely due to a colourant present in said composition.

20 16. A paper based container containing the composition of any one of claims 1 to 7 or a composition obtainable from the method according to claim 8 or claim 9.

25 17. Use of the composition of any one of claims 1 to 7 or a composition obtainable from the method according to claim 8 or claim 9 to reduce the levels of volatile organic compounds in a paint.

30

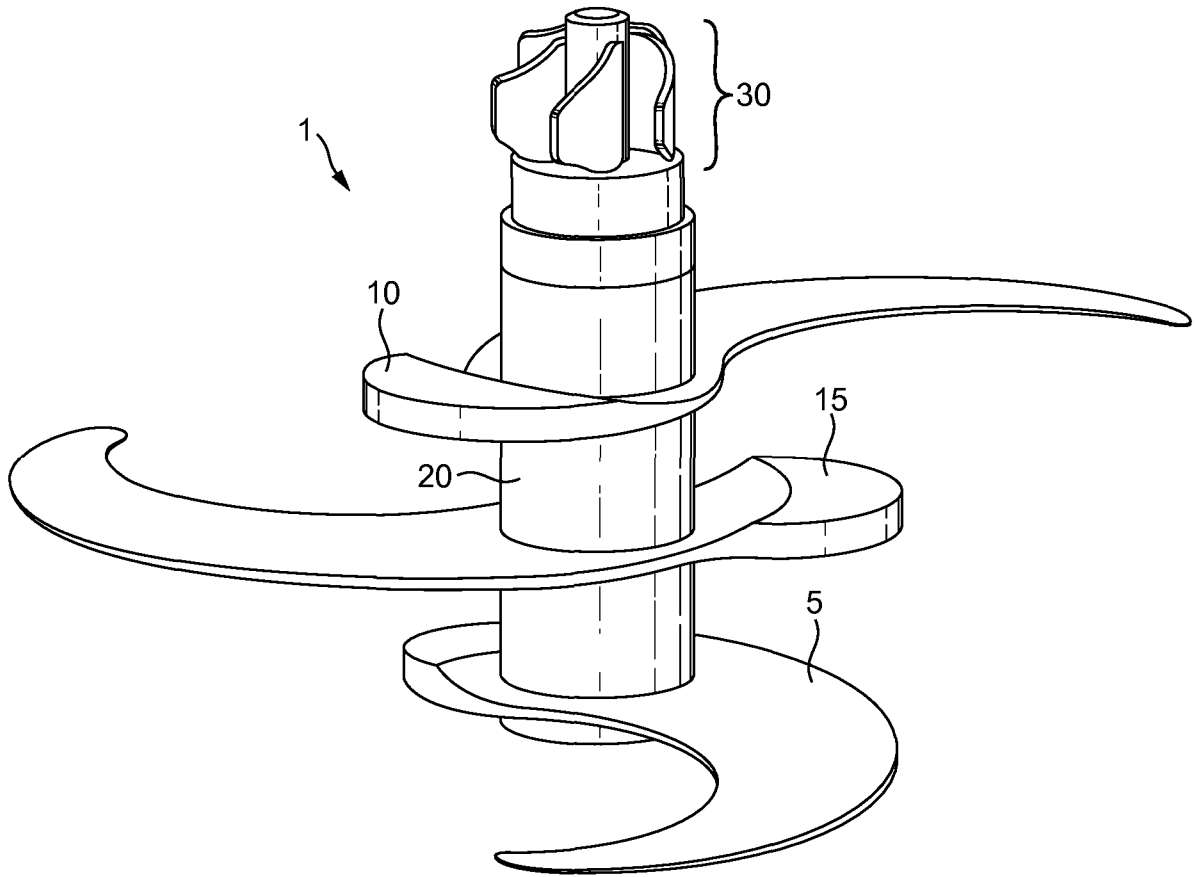

FIG. 1

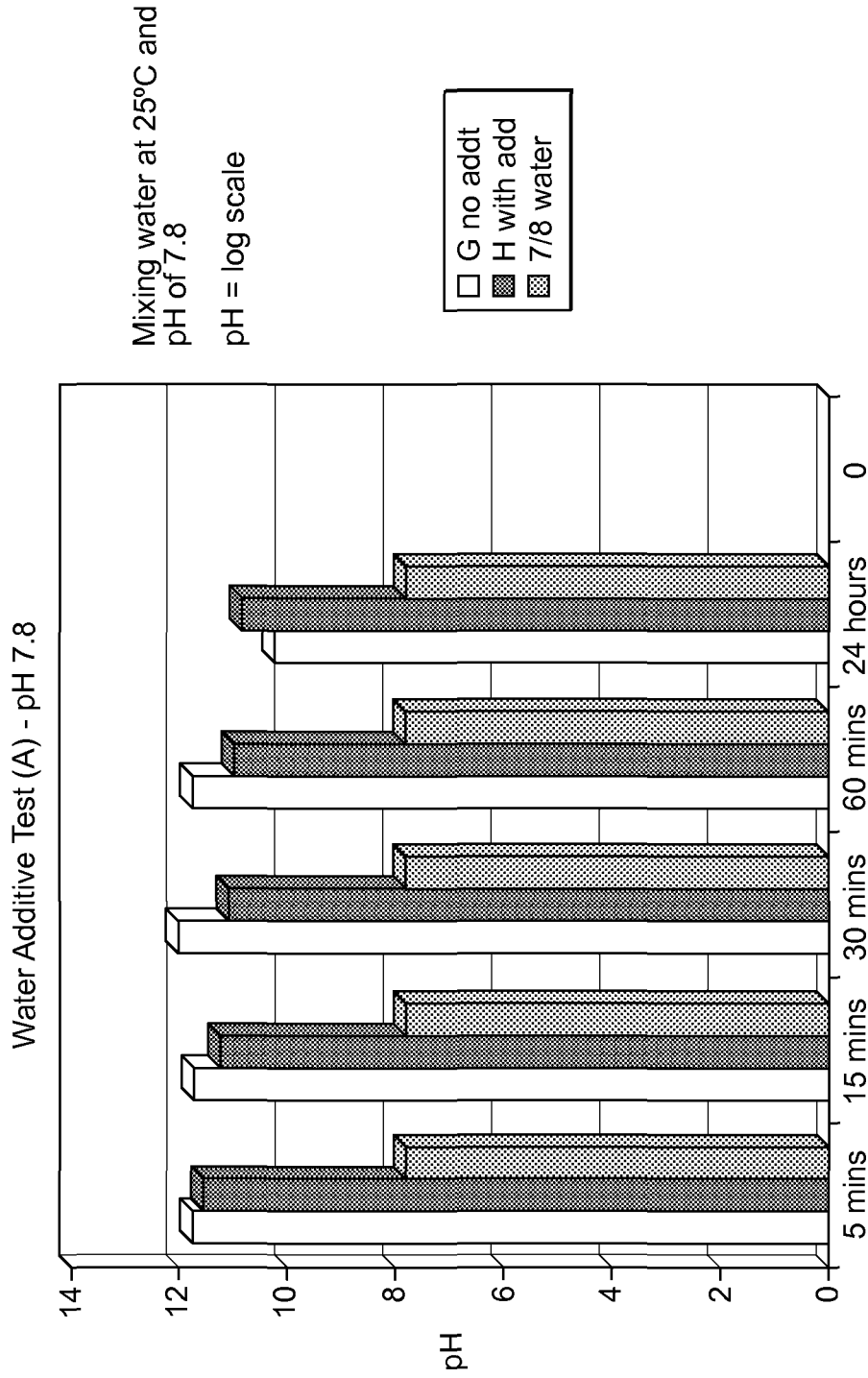

FIG. 2

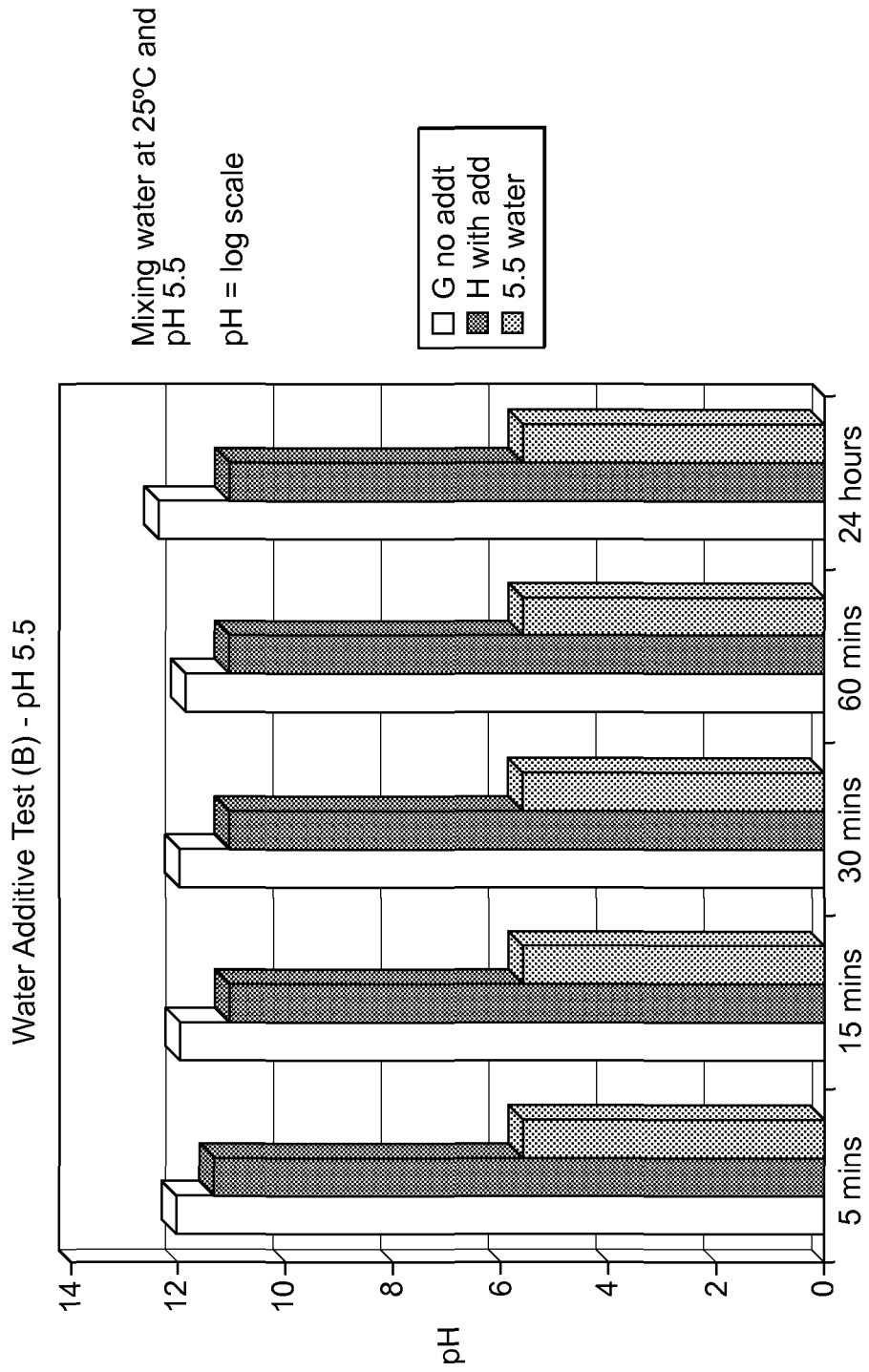

FIG. 3

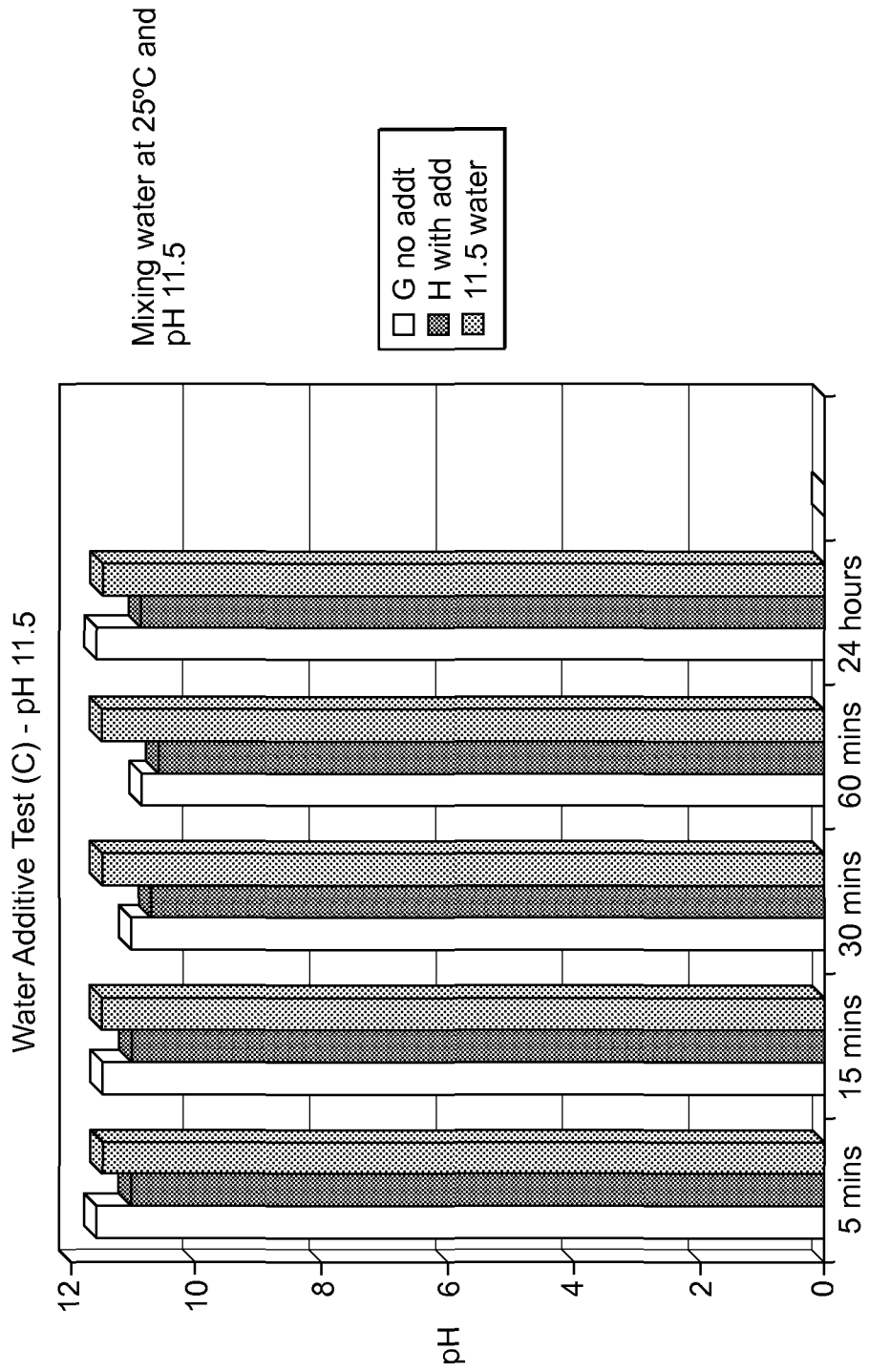

FIG. 4

Sample E-wet sample-plate ground with NO water additive
350x mag-actual image size, reflected light.

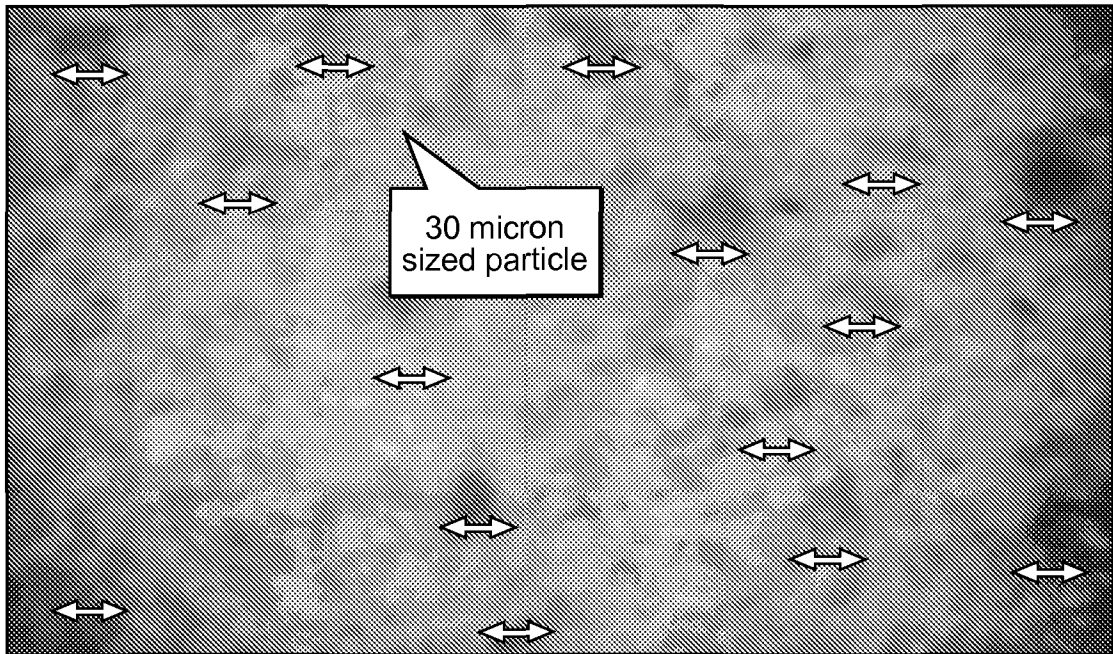

FIG. 5

Sample H-wet sample-fine ground with water additive
350x mag-actual image size, reflected light.

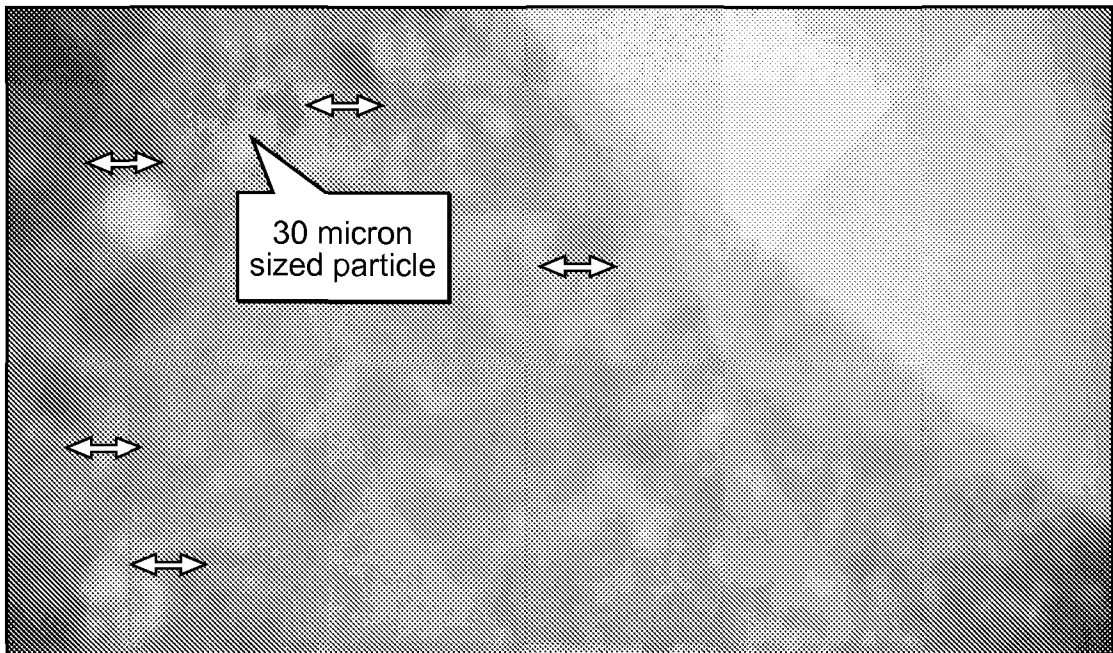

FIG. 6

Sample E-wet sample-plate ground with NO water additive
80x mag-actual image size, reflected light.

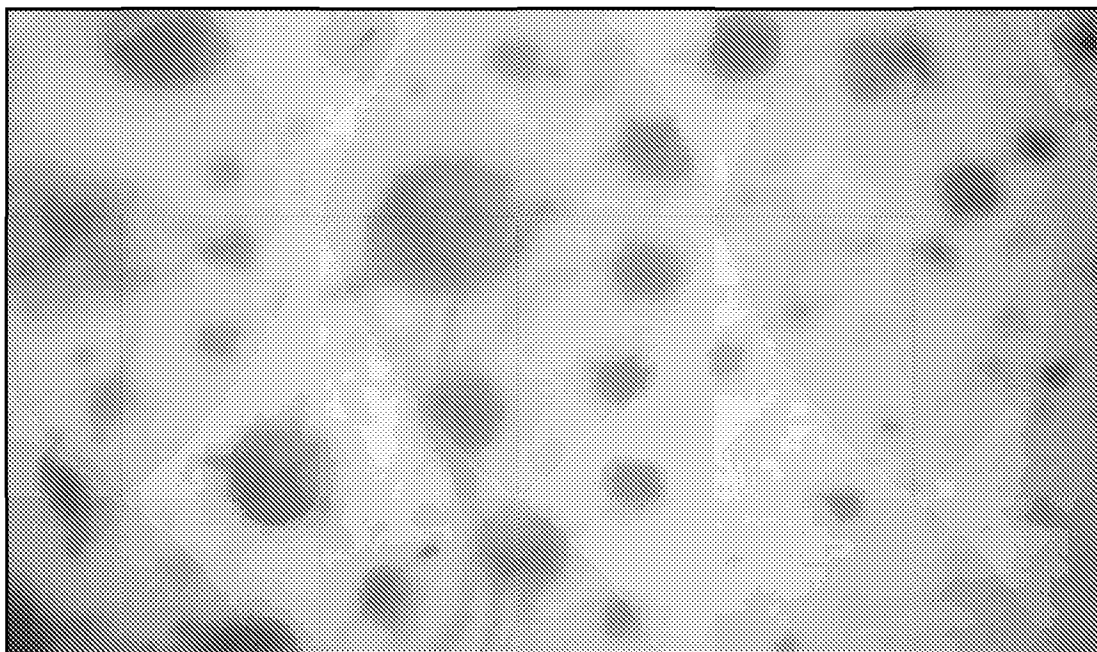

FIG. 7

Sample H-wet sample-fine ground with water additive
80x mag-actual image size, reflected light.

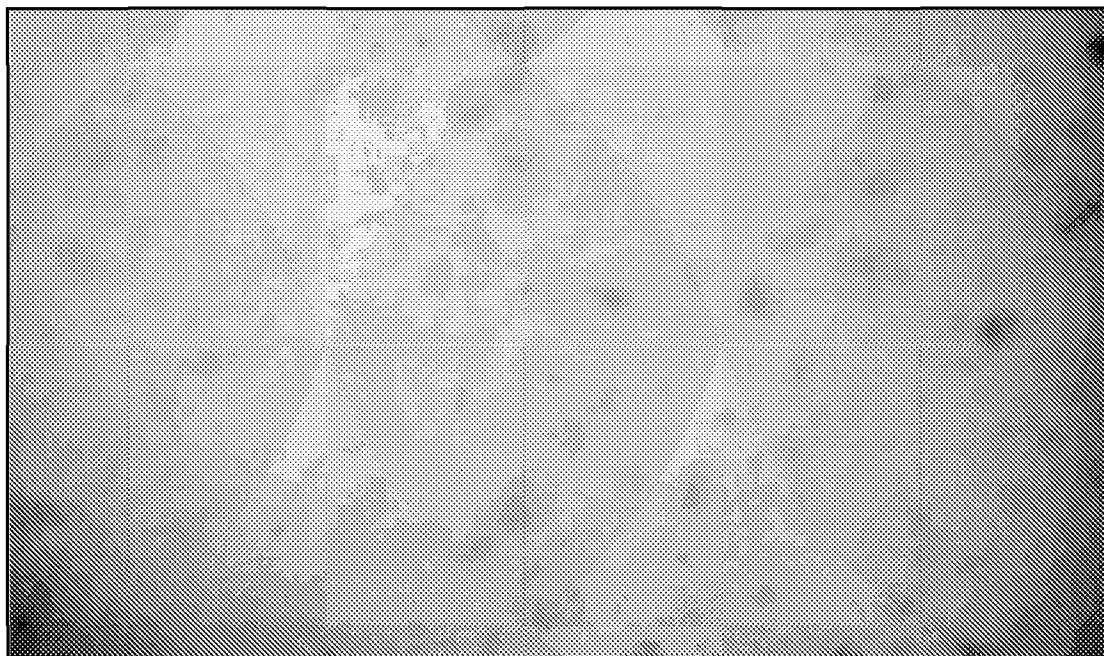

FIG. 8

INTERNATIONAL SEARCH REPORT

International application No
PCT/GB2013/050890

A. CLASSIFICATION OF SUBJECT MATTER
 INV. C09D5/03 C09D103/02 C09D105/00 C09D189/00
 ADD.
 According to International Patent Classification (IPC) or to both national classification and IPC

B. FIELDS SEARCHED
 Minimum documentation searched (classification system followed by classification symbols)
 C09D

Documentation searched other than minimum documentation to the extent that such documents are included in the fields searched

Electronic data base consulted during the international search (name of data base and, where practicable, search terms used)
 EPO-Internal, BIOSIS, COMPENDEX, INSPEC, WPI Data

C. DOCUMENTS CONSIDERED TO BE RELEVANT

Category*	Citation of document, with indication, where appropriate, of the relevant passages	Relevant to claim No.
X	GB 2 443 026 A (HARLING STUART ROSS RHIND [GB] HARLING STUART ROSS RHIND [GB]; NATURE) 23 April 2008 (2008-04-23)	1-8, 10-17
Y	the whole document	9
X	EP 2 402 402 A1 (SPRING COLOR S R L [IT]) 4 January 2012 (2012-01-04) claims; examples	1-8, 10-17
X	GB 553 582 A (WILLIAM JAMES RANDALL; STANLEY COLSTON AUGUSTUS KETHR) 27 May 1943 (1943-05-27) page 2, line 60 - page 3, line 45	1,2,6-8, 11-17
Y	GB 711 653 A (RONALD HAROLD MAPP; RICHARD SALISBURY HILL) 7 July 1954 (1954-07-07) claims; figure 1	9

Further documents are listed in the continuation of Box C.

See patent family annex.

* Special categories of cited documents :

- "A" document defining the general state of the art which is not considered to be of particular relevance
- "E" earlier application or patent but published on or after the international filing date
- "L" document which may throw doubts on priority claim(s) or which is cited to establish the publication date of another citation or other special reason (as specified)
- "O" document referring to an oral disclosure, use, exhibition or other means
- "P" document published prior to the international filing date but later than the priority date claimed

- "T" later document published after the international filing date or priority date and not in conflict with the application but cited to understand the principle or theory underlying the invention
- "X" document of particular relevance; the claimed invention cannot be considered novel or cannot be considered to involve an inventive step when the document is taken alone
- "Y" document of particular relevance; the claimed invention cannot be considered to involve an inventive step when the document is combined with one or more other such documents, such combination being obvious to a person skilled in the art
- "&" document member of the same patent family

Date of the actual completion of the international search 29 May 2013	Date of mailing of the international search report 07/06/2013
---	---

Name and mailing address of the ISA/ European Patent Office, P.B. 5818 Patentlaan 2 NL - 2280 HV Rijswijk Tel. (+31-70) 340-2040, Fax: (+31-70) 340-3016	Authorized officer Vaccaro, Eleonora
--	--

INTERNATIONAL SEARCH REPORT

Information on patent family members

International application No

PCT/GB2013/050890

Patent document cited in search report	Publication date	Patent family member(s)	Publication date
GB 2443026	A	23-04-2008	NONE
EP 2402402	A1	04-01-2012	NONE
GB 553582	A	27-05-1943	NONE
GB 711653	A	07-07-1954	NONE