

No. 646,516.

Patented Apr. 3, 1900.

J. R. BROWN.
ROCK CRUSHER.

(Application filed Jan. 17, 1899.)

(No Model.)

2 Sheets—Sheet 1.

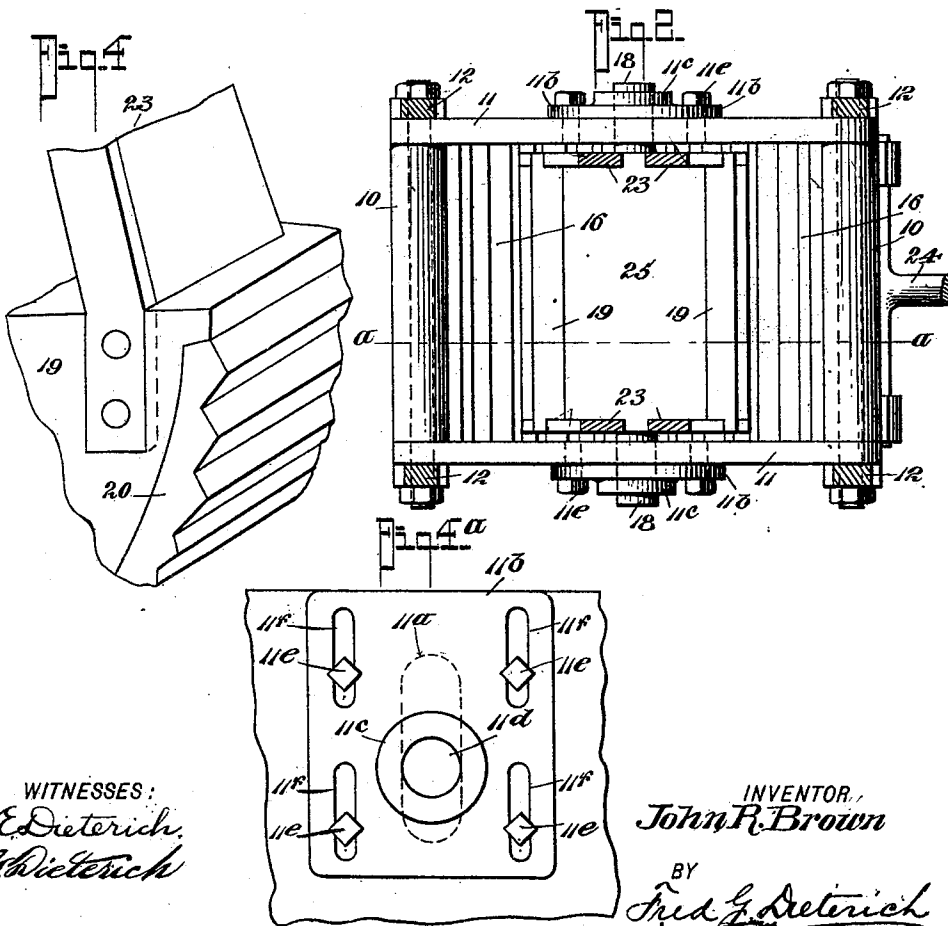
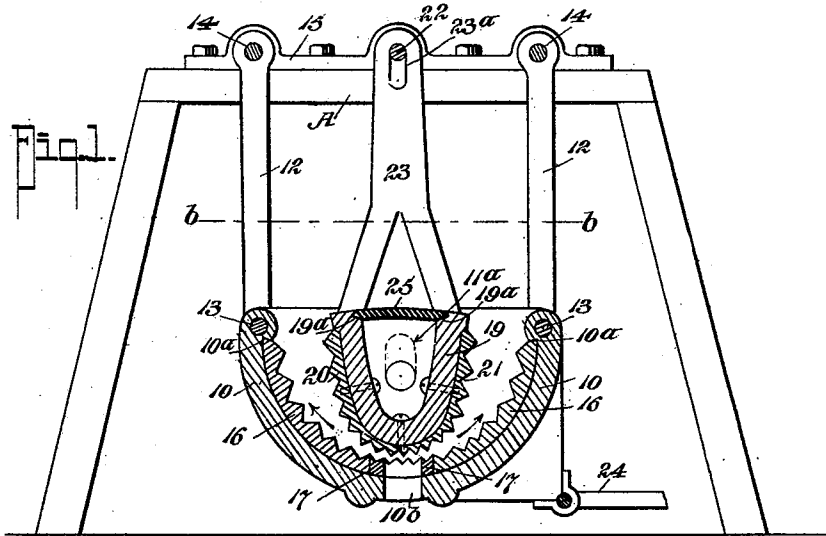

WITNESSES:

W. E. Dieterich,
H. C. Dieterich

INVENTOR,
John R. Brown

BY
Fred G. Dieterich
ATTORNEY.

No. 646,516.

Patented Apr. 3, 1900.

J. R. BROWN.
ROCK CRUSHER.

(Application filed Jan. 17, 1899.)

(No Model.)

2 Sheets—Sheet 2.

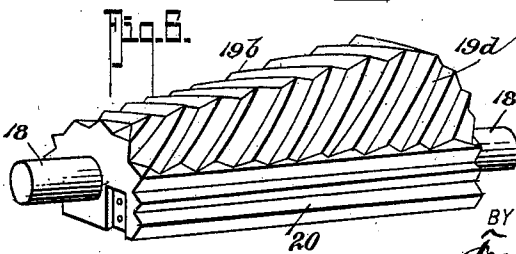
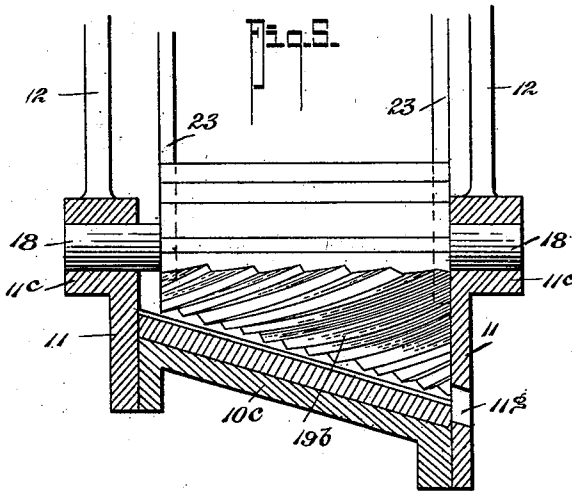
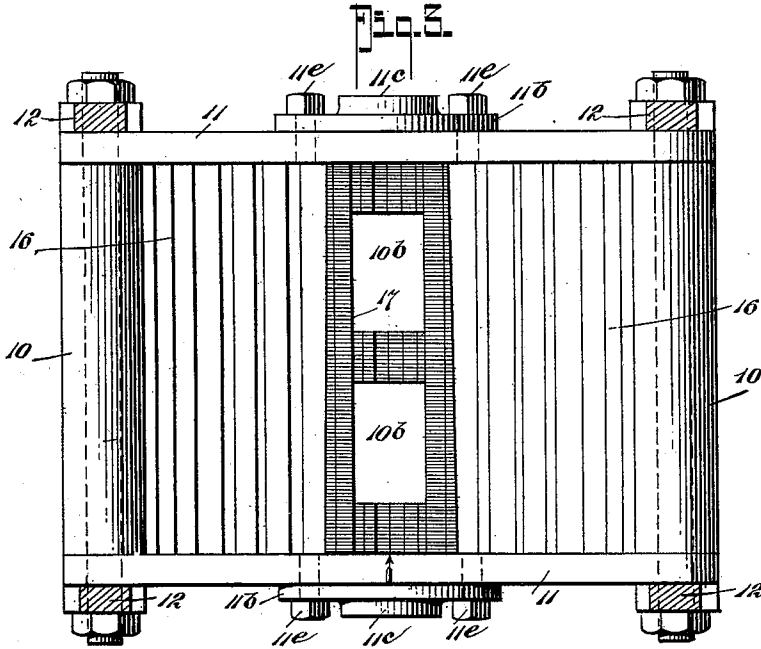

WITNESSES:

A. Dieterich
H. Dieterich

INVENTOR

John R. Brown

BY

Fred G. Dieterich
ATTORNEY.

UNITED STATES PATENT OFFICE.

JOHN REITTER BROWN, OF HARRISON HOT SPRINGS, CANADA.

ROCK-CRUSHER.

SPECIFICATION forming part of Letters Patent No. 646,516, dated April 3, 1900.

Application filed January 17, 1899. Serial No. 702,424. (No model.)

To all whom it may concern:

Be it known that I, JOHN REITTER BROWN, a citizen of the Dominion of Canada, residing at Harrison Hot Springs, in the Province of British Columbia, Canada, have invented certain new and useful Improvements in Rock-Crushers, of which the following is a specification.

My invention relates to improvements in rock-crushers in which a pendulous body is arranged within an oscillating bed pivotally suspended from its opposite sides; and the object of my improvement is to provide a bed having a suitable concavity with teeth or corrugations arranged therein pivotally suspended by its opposite sides to suitable supports on the same horizontal plane and an internal crusher or pendulum supported at its opposite ends and suspended intermedially between the supports of the said bed and controlled by the movement of the same by trunnions fixed in the internal body passing through apertures in its opposite ends, whereas, by the oscillation of the bed which rises and falls in its motion from side to side, the internal body or crusher will also rise and fall and have a rocking movement in relation to the movement of the bed. I attain this object by the mechanism illustrated in the accompanying drawings, in which—

Figure 1 shows a vertical cross-section of my machine on the line *a a* in Fig. 2. Fig. 2 shows a horizontal plan of the apparatus, taken on the line *b b* in Fig. 1. Fig. 3 shows a plan of the bed with the internal-rocking crusher removed. Fig. 4 is a detail of a portion of the internal body or crusher, showing the means of fastening for the pendulum-arms; and Fig. 4^a shows a detail of the vertically-adjustable trunnion-supports in which the trunnions of the internal crusher are journaled. Fig. 5 shows a section of a modification of my crusher which is intended for use in the laboratory or where the crushing is to be done on a small scale. Fig. 6 is an inverted perspective view of the internal body or crusher to be used in this modification. As shown in Figs. 5 and 6, the internal crusher has its lower plane at a sloping angle similar to the bed, and the crushed rock is allowed to escape through an opening in the end plate on the lower plane of the bed.

Similar letters and numerals refer to similar parts throughout the several views.

The bed 10 is preferably of cast-iron, made in the form shown, with a fluted or concaved hollow therein. This is of semicircular form and is machined out with undercut grooves 10^a on its opposite sides, and at the center is provided openings 10^b, for a reason to appear presently. Securely bolted to the opposite ends of the bed and covering the openings caused by the flute are end plates 11. In the center and near the tops of these plates are slots 11^a, which are placed in a vertical manner. Arranged over these slots 11^a on the plates 11 are plates 11^b, having bosses 11^c with apertures 11^d therein. These plates 11^b are susceptible of being moved up or down parallel to the slots 11^a by means of set-screws 11^e, passing through slots 11^f therein and taking into the plates 11, the object of which will be made clear presently.

The bed 10 is suspended by arms 12, connected to the opposite ends of rods 13, which pass through and journal in the opposite upper sides of the said bed, the upper end of the said arms being supported in a pivotal manner to rods 14, arranged to lie in suitable bearings 15 in a supporting-frame A.

As better shown in Figs. 1 and 3, the inner surface of the concaved surface of the bed 10 is formed of sections or plates 16 of "chilled" iron. These plates or sections are fitted into the dovetails 10^a on each side, and the center piece 17 is formed slightly wedge-shaped, so that by having a snug fit it may be driven into place in the direction of the arrow and will force the section 16 into the grooves 10^a and will hold them there without the employment of bolts or other fastenings. The inserting of the said plates is done with the plate 11 on the end of the bed occupied by the wide end of the center piece 17 removed, and when such plate is replaced the several sections will be securely held in their respective positions. The inner surface of the plates or sections 16 and 17 are fluted or corrugated lengthwise thereof, and these corrugations are graduated from a coarse rib on their upper sides to a smaller flute on the section 17 at the center. This provides suitable breaking or abrading edges for the rock, which diminish toward the center as the rock is reduced. Ar-

ranged in the center of the bed and pivoted on trunnions 18, passing through the apertures 18^a in the ends of the oscillating bed 10 (see dotted lines, Figs. 1 and 4^a) and journaled in the oppositely-disposed bosses 11^c on the plates 11^b, is a central pendulous body or crusher 19. This crusher 19 is preferably of elliptical form on its depending side, and such lower side when rocked is arranged to describe part of a circle in proximity to the inner circle of the plates 16 and 17, the full object of which will appear presently. On the outer surface of the crusher 19 are secured chilled plates 20 and 21, having similar abrading-surfaces to the plates 16 and 17. These plates are secured to the central body by bolts passing therethrough and to the cavity within the crusher. Connecting with the opposite corners of the crusher 19 and with a rod 22, resting on the bearings 15, intermediately between the rods 14, are arms 23. These arms 23 are rigidly fixed to the crusher, and by reason of their upper ends being pivoted when an oscillating movement is imparted to the bed 10 the said crusher will roll therein and contract and expand the spaces on each side thereof between its sides and the inner walls of the bed. This will crush and reduce any matters placed within the spaces on each side of the crusher, the said spaces acting as mouths and the sides of the crusher and the bed acting as jaws, which gradually contract until the space is very limited between the bodies, which provides for the rock being ground comparatively fine.

By reason of the plates 11^b to receive the bearings or trunnions 18 being adjustably fixed and the upper ends of the arms 23 being provided with slots 23^a therein it is obvious that the internal crushing-body 19 may be poised at various distances from the contour of the bed 10, and consequently the rock may be broken fine or coarse, as the requirements demand.

Motive power is attached to the pitman 24, which is pivoted to the bed 10. This may be connected directly with an engine or driven by a crank-shaft, the requirement being merely to set the bed 10 in motion and the crusher 19 will be rolled within the same, which rocking movement provides a grinding and a crushing action on each side of the crusher. To prevent the rock from dropping into the concavity in the crusher and thus interfering with the removing of the bolts for changing the plates 20, I provide a cover or guard 25, which is set in notches or grooves 19^a in the inner sides of the walls of the crusher 19. Any rock that falls on this will be deflected into the opening on each side to be crushed.

In the operation of my improved crusher oscillating movement is imparted to the bed 10, which swings on arms 12. This movement must be sufficient to give the internal crusher 19 the desired roll. The rock is dropped into the machine from a convenient

hopper arranged above the swinging bed, and as the oscillation goes on the same will be reduced and passed through the apertures 10^b in the lower part of the bed.

As before intimated and illustrated in Figs. 5 and 6, I provide a modification to be employed for breaking and pulverizing rock to a much finer degree. In this the bed 10^c is placed on a sloping plane, so that the pulverized rock will travel toward the lower end. At the lower side of the bed is an opening 11^e for the passage of the broken rock instead of the openings 10^b, as illustrated in Fig. 3. The crusher 19^b being larger at one end than the other is formed to work within the sloping bed, and consequently the lower end will have a greater travel over the bed than the opposite end. As shown in Fig. 6, instead of having the longitudinal ribs or flutes on the bottom of the crusher 19^b, as in the crusher 19, these flutes are formed in an oblique angle across the opposite sides of the bottom and terminate in the center, as at 19^d, and the sides are fluted in the usual parallel manner, as at 20. As better shown in Fig. 5, the rock is fed into the space between the small end of the crusher and the end plate 11 and the space between the crusher and the bed is gradually converged until the opposite end of the crusher moves in close proximity to the bed. Thus it is seen that as the rock becomes reduced it will gravitate toward the lower end of the crusher and must before being ejected from the machine be reduced to a comparatively-fine pulp. By reason of the abrading-flutes on the bottom of the crusher 19^b being placed at an angle with the flutes in the bed 10^c the rock in course of reduction must pass beneath the ribs 19^d, which will have a tendency to retard its progress until it is ground comparatively fine. This will not only break the rock, but will pulverize it also before it is ejected from the opening 11^e. The frame A, here illustrated for supporting the crusher, is no part of my invention. Therefore it is evident that this may be modified to suit the requirements. For instance, the crusher may be suspended from a floor and the rock fed to it through a chute in the same. This should bring the discharge approximately on the floor beneath. The oscillating power would, of course, be arranged on approximately the same plane as the discharge.

Having described my invention, what I claim as new, and desire to be protected in by Letters Patent of the United States, is—

1. In a rock-crusher; an oscillating mortar or bed; in combination with a crusher pivotally connected with the body of the mortar to oscillate therewith, and means for imparting a rocking motion to the crusher upon its pivotal bearings in reverse directions as the mortar is oscillated, substantially as shown and described.

2. A rock-crusher, comprising an oscillating mortar or bed; a crusher pivotally connected with the body of the mortar and held

to oscillate with it, said crusher being adjustable to or from the grinding-face of the mortar, and means for imparting a rocking motion to the crusher as it is oscillated with the mortar as specified.

3. The combination with the mortar or bed 10; a supporting-frame or link-arms 12 12 pivotally hung from said frame and pivotally connected to the opposite sides and ends of the mortar or bed, and means for oscillating the bed 10; of a crusher 19 pivotally hung within the bed 10; and the arms 23 fixedly secured to the crusher 19, their upper ends being pivotally connected to the fixed member of the supporting-frame and at a point intermediate of the pivoted joints of the member 12.

4. The combination with the mortar or bed 10; a supporting-frame; the link-arms 12 12, pivotally hung at their upper ends on such frame, their lower ends being pivotally joined to the mortar or bed at the opposite ends thereof, and means for oscillating the bed 10; of the crusher 19 pivotally hung within the bed 10; the arms 23 fixedly secured to the crusher 19, the upper ends of said arms being pivotally connected to the fixed member of the supporting-frame at a point intermediate of the pivotal point of the members 12, said arms 23 having a slidable connection with the said fixed member, and means for changing the pivotal axis of the said crusher 19 relatively to the mortar or bed, all being arranged substantially as shown and described.

5. The combination in a rock-crushing machine of the character stated, with the mortar or bed 10, having elongated vertical slots 11^a, in the side walls thereof; bearing-plates 11^b vertically adjustable upon the said slotted ends of the mortar, said plates having journals to receive the pivots of the crusher; means for oscillating the mortar or bed; the crusher 19, said crusher having the axles at the opposite ends adapted to extend through

the slots 11^a, in the end walls of the mortar and engage with the bearings in the vertically-adjustable plate 11^b, the arms 23 connected to the crusher 19, said arms having elongated slots 23^a, and the pivoted bearing-rod 22; all being arranged substantially as shown and described.

6. The combination with a grinding concave mortar or bed having a central rock-discharging aperture, said mortar having undercut grooves 10^a, at the upper end and having detachable end members 11; grinding-surfaces detachably held within the mortar, their upper edges being arranged to engage with and be held in a locked engagement by the grooves 10^a, and a slotted wedge member adapted to enter between the adjacent lower edges of said grinding-surfaces; and a crusher held within the mortar; and means for rocking the same as the mortar is oscillated, all being arranged substantially as shown and for the purposes described.

7. The combination with the bed having a grinding-surface, said bed being supported on arms pivotally connected at their upper ends to the supporting-frame, the ends of the mortar having elongated slots; bearing-plates secured upon the outside of the mortar and vertically adjustable thereon, said plates having bosses 11^c; an internal crusher having external crushing-surfaces and having end trunnions 18, adapted to project through the slots within the end walls of the mortar and engage the bosses 11^c; an and upwardly-projecting member secured to the said crusher, said member being pivotally connected to and fixedly held on the supporting-frame, all being arranged substantially as shown and for the purposes described.

JOHN REITTER BROWN. [L. S.]

Witnesses:

CHAS. WILSON,
G. R. SMALL.