



HU000025637T2

(19) **HU**(11) Lajstromszám: **E 025 637**(13) **T2****MAGYARORSZÁG**
Szellemi Tulajdon Nemzeti Hivatala**EURÓPAI SZABADALOM**
SZÖVEGÉNEK FORDÍTÁSA(21) Magyar ügyszám: **E 12 720301**
(22) A bejelentés napja: **2012. 03. 30.**(51) Int. Cl.: **B65D 858/04** (2006.01)
A47J 31/06 (2006.01)(96) Az európai bejelentés bejelentési száma:
EP 20120720301(86) A nemzetközi (PCT) bejelentési szám:
PCT/PT 12/000011(97) Az európai bejelentés közzétételi adatai:
EP 2692663 A2 **2012. 10. 04.**(87) A nemzetközi közzétételi szám:
WO 12134312(97) Az európai szabadalom megadásának meghirdetési adatai:
EP 2692663 B1 **2015. 09. 09.**(30) Elsőbbségi adatok:
10559811 **2011. 03. 30.** **PT**(73) Jogosult(ak):
Novadelta-Comércio e Industria de Cafés,
S.A., 1950-406 Lisboa (PT)(72) Feltaláló(k):
NABEIRO, Rui Miguel, P-7370-112 Campo Maior (PT)
Freire Falcão Teles Caramelo, Daniel, 1400-701 Lisboa
(PT)(74) Képviselő:
dr. Harsányi Zita, Budapest(54) **Kapszula vezérelt nyílással, eljárás és eszköz a kapszula működtetésére**

Az európai szabadalom ellen, megadásának az Európai Szabadalmi Közlönyben való meghirdetésétől számított kilenc hónapon belül, felszólalást lehet benyújtani az Európai Szabadalmi Hivatalnál. (Európai Szabadalmi Egyezmény 99. cikk(1))

A fordítást a szabadalmas az 1995. évi XXXIII. törvény 84/H. §-a szerint nyújtotta be. A fordítás tartalmi helyességét a Szellemi Tulajdon Nemzeti Hivatala nem vizsgálta.



(11) **EP 2 692 663 B1**

(12) **EUROPEAN PATENT SPECIFICATION**

(45) Date of publication and mention of the grant of the patent:
09.09.2015 Bulletin 2015/37

(51) Int Cl.:
B65D 85/804 (2006.01) A47J 31/06 (2006.01)

(21) Application number: **12720301.6**

(86) International application number:
PCT/PT2012/000011

(22) Date of filing: **30.03.2012**

(87) International publication number:
WO 2012/134312 (04.10.2012 Gazette 2012/40)

(54) **CAPSULE WITH CONTROLLED OPENING, PROCESS AND DEVICE FOR OPERATING THE CAPSULE**

KAPSEL MIT KONTROLLIERTER ÖFFNUNG, VERFAHREN UND VORRICHTUNG FÜR DEN BETRIEB DER KAPSEL

CAPSULE À OUVERTURE CONTRÔLÉE, PROCÉDÉ ET DISPOSITIF POUR LA MISE EN OEUVRE DE CETTE CAPSULE

(84) Designated Contracting States:
AL AT BE BG CH CY CZ DE DK EE ES FI FR GB GR HR HU IE IS IT LI LT LU LV MC MK MT NL NO PL PT RO RS SE SI SK SM TR

(30) Priority: **30.03.2011 PT 10559811**

(43) Date of publication of application:
05.02.2014 Bulletin 2014/06

(73) Proprietor: **Novadelta-Comércio e Industria de Cafés, S.A.**
1950-406 Lisboa (PT)

(72) Inventors:
• **NABEIRO, Rui Miguel**
P-7370-112 Campo Maior (PT)

• **FREIRE FALCÃO TELES CAMELO, Daniel**
1400-701 Lisboa (PT)

(74) Representative: **Miranda de Sousa, João Paulo Vaz**
Garrigues IP, Unipessoal Lda.
Av. da República, 25-1°
1050-186 Lisboa (PT)

(56) References cited:
EP-A1- 2 210 826 WO-A1-2010/137947
WO-A1-2011/035942 WO-A1-2011/138405
DE-A1-102010 030 988 US-A1- 2008 028 946
US-A1- 2010 154 644

EP 2 692 663 B1

Note: Within nine months of the publication of the mention of the grant of the European patent in the European Patent Bulletin, any person may give notice to the European Patent Office of opposition to that patent, in accordance with the Implementing Regulations. Notice of opposition shall not be deemed to have been filed until the opposition fee has been paid. (Art. 99(1) European Patent Convention).

Description

Field of the Invention

[0001] The present invention refers to the field of capsules for aromatic substances used for the preparation of beverages by extraction, by means of its crossing by a pressurized fluid flow, in general, and to the field of capsules for obtaining coffee of the espresso type, in particular.

[0002] The present invention further refers to a process and device for the operation of said capsule.

Background of the Invention

[0003] The extraction of aromatic substances inside of a capsule by means of a pressurized fluid flow has a determinant importance upon the quality of the resulting beverage. In what refers to the entry and exit of the flow, the solution usually applied in the prior art relates to a certain form of rupture of a construction material used in at least one certain zone of the capsule. Any form of rupture of a construction material, leas as a rule to a different outcome, notably in terms of the resulting configuration of the section and area of the passageway made available for entry or exit of the flow.

[0004] In particular, it is important to consider the configuration and distribution of the flow at the entry, so as to spread across the volume occupied by the aromatic substance in the most effective possible way. In this respect, both the section of the passageway as the path of the flow, immediately after entering or before leaving the capsule, have an overriding influence upon the extraction efficacy and several other properties of the beverage obtained. In particular, maximizing the area distribution of the pressurized flow right at the entry, so as to cross the biggest possible fraction of the volume of aromatic substance contained in the capsule, presents several advantages.

[0005] Moreover, it is known the advantage associated with the flow remaining during a certain period of time inside the capsule, usually controlled by the hydraulic force thus generated, notably when the latter is sufficient to actuate mechanical means of rupture or perforation of such a zone of the capsule, external or internal to the capsule. In this respect, it will be advantageous to provide a simpler solution in construction terms, for a space of temporary flow retention, and bigger control upon the flow exit conditions. According to another aspect, in many cases of resorting to internal perforation means, it is known the need to use one exterior element in this zone, so as to ensure the airtightness of the capsule, which results disadvantageous in terms of production costs and simplicity of recycling of the capsules.

[0006] Documents WO 2008/087099 A2, WO 2005/020769 A1 and EP 1243210 A1 disclose capsules according to the aforementioned technical field. Patent EP 1826148 B1 discloses an element disposed at the

entry of a capsule and dividing the fluid flow upstream into several fluxes distributed and oriented so as to attain a more effective distribution of the fluid flow within the volume occupied by the aromatic substance.

[0007] In particular, documents EP 2210826 A1 and US 2008/028946 A1 disclose capsules according to the aforementioned technical field and presenting releasable flow passageways.

10 General description of the Invention

[0008] The goal of the present invention is to make available a capsule that allows a bigger control upon the flow conditions at the entry and exit, as well upon the distribution of said flow inside the capsule, in particular including the configuration and dimension of the sections of flow passageways at the entry and exit of the capsule, so as to increase the efficacy of the extraction of the aromatic substance in its interior.

[0009] Yet another goal of the present invention is to eliminate the need for using different construction materials outside of the capsule, such as for example aluminum, so as to ensure substantial airtightness conditions thereof.

[0010] Within the scope of the present invention, by "capsule" one should understand a recipient defining an interior volume for collecting an aromatic substance, presenting at least one zone facing the flow upstream, configured for example in the form of a substantially cylindrical box, or in the form of a shell, and produced in a substantially rigid or substantially flexible material, and substantially gastight or not.

[0011] The goals above are solved according to the invention by means of a capsule built by at least one construction element that defines at least one zone of capsule facing the flow upstream, preferentially also a zone of capsule facing the flow downstream, and including at least one controlled opening element, retained in a removable manner in a respective element fixture disposed in the zone facing the flow upstream and/or in the zone facing the flow downstream, respectively, so that by means of applying at least one actuation force, preferentially previously defined, upon a respective controlled opening element, the latter is displaced from a initial position of retention to a following position of retention in a respective element fixture, thereby releasing at least one previously defined section of flow passageway, provided in the controlled opening element and/or in respective element fixture.

[0012] The present invention thus provides sections of flow passageways, at the entry and/or at the exit of the capsule, whose configuration and dimension may be previously defined and whose instant of opening may be controlled with high reliability by means of the application of a respective actuation force, without provoking any rupture or discontinuity of any construction material of the capsule. In particular, these sections of flow passageways are previously defined in the controlled opening

elements and/or respective element fixtures, so that they may be differently configured in view of the required type of flow pattern, for example according to the type of aromatic substance, without having for such purpose to vary remaining construction elements of the capsule.

[0013] In a preferred embodiment of the capsule according to the invention, the latter presents at least one controlled opening element in the zone of the capsule facing the flow upstream, preferentially also in the zone facing the flow downstream, disposed in each case preferentially in a substantially centred manner. According to a preferred embodiment, said controlled opening element, when in a initial position of retention and/or in a following position of retention, is retained preferentially by means of at least one friction union and/or of an union by means of positive locking, in at least one respective element fixture.

[0014] According to another inventive aspect, said section of flow passageway is provided by at least one, preferentially a plurality of passageways and/or by a region occupied by a liquids permeable material and/or with filtering effect. In particular, in view of maximizing the flow distribution at the entry, along the direction transversal to the prevailing flow direction through the capsule, the controlled opening element and/or respective element fixture, presents several passageways, preferentially disposed on its side faces, whereby said passageways are un-obstructed or result in fluid communication with each other, by means of the displacement of the controlled opening element. According to experiments that have been carried out, this embodiment presents a substantial advantage when compared to the introduction of the flow concentrated in the central zone of the capsule. Moreover, the use of a plurality of passageways in the controlled opening element and/or in a respective element fixture, allows a diversity of particular options in terms of the distribution and configuration of said passageways, both at the entry as at the exit of the capsule, and, henceforth, of the flow patterns developing inside the capsule.

[0015] According to another aspect of the invention, the displacement of the controlled opening element releases an increasing section of flow passageway, disposed substantially along a prevailing flow direction and/or along a radial direction. In a preferred embodiment, the several passageways are disposed preferentially in a symmetrical manner along the perimeter of the controlled opening element and/or respective element fixture.

[0016] According to another inventive aspect, the, at least one, section of flow passageway is released as a result of a respective displacement at least linear or rotating, preferentially of a linear and rotating displacement, by the controlled opening element. Thus, it is possible to configure the passageways in such a way that it results a section of flow passageway with a certain radial evolution, leading to a corresponding flow distribution inside the capsule. This aspect is particularly advantageous in the case that the pressurized fluid flow crosses the cap-

sule (prevailing flow direction) along a substantially horizontal direction.

[0017] In this respect, in a particularly preferred embodiment, the passageways are provided in such a number, distribution, including radial distribution, dimension and spatial orientation, that the displacement of the controlled opening element distributes the pressurized fluid flow to at least one distance of reach, preferentially in at least two distances of reach, along a radial direction relatively to the perimeter of the section of passageway.

[0018] In another preferred embodiment, the passageways of the controlled opening element and/or of a respective element fixture, present a dimension and/or format that varies in each case along the radial direction across the perimeter of the section of flow passageway. In a particularly preferred embodiment, the ways are disposed in asymmetrical manner, so as to generate a certain prevailing flow path, for example substantially circular downwards inside the aromatic substance, when the capsule is placed in such an extraction position that the prevailing flow direction is substantially horizontal. Moreover, it is preferred when the passageways of the controlled opening element and/or of a respective element fixture, present a dimension and/or format that varies in each case at least along the respective perimeter.

[0019] It is thus provided a set of advantageous options that allow a substantial control upon the configuration of the section of passageway, moment of opening and associated energy loss, as well as prevailing flow path followed by the pressurized flow as it enters inside the capsule according to the invention. Moreover, there is the possibility of exerting a substantial influence upon the flow distribution pattern at the entry, and inherently, the following internal evolution of the flow inside the capsule, and henceforth, the efficacy of extraction of the respective aromatic substance.

[0020] In a capsule according to the invention, is preferred when the controlled opening element is configured in a substantially tubular form, or in a ring form, preferentially of circular cross section. In a preferred embodiment, the end-side of the controlled opening element facing the flow upstream is provided open and the end-side facing the flow downstream is provided closed.

[0021] According to another preferred embodiment of the invention, the controlled opening element is disposed in the capsule so as to initially retain a certain amount of pressurized fluid flow in its interior, at least until it is displaced to a following retention position. In particular, it is preferred when the controlled opening element presents a configuration of the cone type in its end on the side of the upstream flow.

[0022] According to tests that have been carried out, it came out as advantageous when the height of the controlled opening element is previously dimensioned so that the displacement of the controlled opening element out of an initial position of retention requires applying a certain actuation force during at least a certain period of time. In particular, in the case of the entry of the flow to

be carried out in the zone of capsule facing the flow upstream, the height of the respective controlled opening element may be previously dimensioned so as to, by means of applying a certain actuation force, displace the controlled opening element out of its initial position of retention to a following position of retention, in which for example it is next to the surface of the aromatic substance inside the capsule.

[0023] According to another preferred embodiment, it may be provided at least one liquid permeable material, preferentially with filtering effect, in the open end-side facing the flow upstream, of the controlled opening element disposed in the zone facing the flow downstream. One herewith avoids the need for using filtering elements directly in the exit of the flow to the outside of the capsule.

[0024] Yet another goal of the present invention is to provide a process for operating a capsule according to the present invention, such that said process takes place with a high degree of control upon the conditions in general, and the distribution and evolution, in particular, of the pressurized flow of fluid at the entry and at the exit of said capsule.

[0025] The aforementioned goal is solved by means of a process for operating a capsule according to the present invention, comprising the steps of introducing a capsule according to the invention into an extraction chamber, fixating the capsule in the extraction chamber by means of mechanical tightening, notably between an infusion head and an infusion discharge, injection of a fluid flow, under a previously defined pressure and period of time through the infusion head, so that by means of the mechanical tightening of the capsule, the infusion head exerts a mechanical actuation force upon the, at least one, controlled opening element retained in removable manner in the zone of capsule facing the flow upstream, so that the, at least one, controlled opening element is displaced in a linear and/or rotating movement, from an initial position of retention to a following position of retention. It is preferred when in this following position of retention, it is released at least one certain section of flow passageway, at least through the zone facing the flow upstream.

[0026] According to a preferred embodiment, by means of mechanical tightening of the capsule, the infusion discharge exerts a mechanical actuation force upon the, at least one, controlled opening element disposed on the zone of capsule facing the flow downstream, so that the latter is displaced in a linear and/or rotating movement, from the initial position of retention to a following position of retention, this way releasing at least one section of flow passageway through the zone facing the flow downstream.

[0027] According to another preferred embodiment, after the beginning of the injection of the pressurized flow of fluid, the latter is immediately introduced inside the capsule through the, at least one, passageway of the controlled opening element and/or respective element fixture.

[0028] According to another preferred embodiment, the pressurized flow of fluid initially accumulates in the controlled opening element and thereby exerts an increasing hydraulic pressure upon the controlled opening element, until reaching such a value that provokes the displacement of the latter from an initial position of retention to a following position of retention. Alternatively, after crossing the capsule, the pressurized flow of fluid is immediately discharged to the outside of the capsule through the passageways of the, at least one, controlled opening element and/or respective element fixture.

[0029] The present invention further proposes a device for using a capsule according to the invention, characterized in that it comprises at least one chamber of extraction for carrying out the process according to the invention.

Description of the Figures

[0030] The invention shall now be explained in greater detail based upon preferred embodiments thereof and on the schematic representations included in the attached Figures. The Figures show:

Figures 1a - 1b: exterior views of two embodiments of a capsule according to the invention, including in each case one controlled opening element;

Figures 2a - 2b: views in cut, according to the plane AA in Figures 1, of controlled opening elements;

Figures 3a - 3b: detail views of a controlled opening element in a capsule, in an initial position (A) and in a following position (B);

Figures 4a - 4b: views in cut, along plane AA of Figures 1a - 1b, of a second set of controlled opening elements;

Figures 5a - 5b: detail views of a controlled opening element in a capsule according to the embodiments of Figures 4, in an initial position (A) and in a following position (B);

Figures 6a - 6b: details of embodiments of the retention of a controlled opening element (5) in a capsule according to the invention, with release of section of passageway by successively applying two actuation forces, respectively;

Figures 7a - 7b: views in cut, along plane AA, of an embodiment of a controlled opening

element in a capsule according to the invention, in an initial position (A) of retention and in a following position (B) of retention, respectively;

Figures 8a - 8b: Schematic diagrams representative of the evolution of the method of processing according to the invention, in steps corresponding to an initial position (A) and a following position (B), corresponding to the position of extraction in an extraction device of said capsule, respectively;

Figures 9a - 9b: views in side cut of a capsule, and in front cut of a controlled opening element in engagement and rotating movement with a respective fluid injection (11) of the extraction device (10) for processing of said capsule.

Detailed description of the invention

[0031] Figures 1a and 1b respectively present embodiments of a recipient of the type capsule (1) and of the type pod (1') according to the invention (henceforth jointly designated by "capsule"), in plan view from above, in side view, and in plan view from underneath, successively from top to bottom. Both capsules (1, 1') are built by at least one construction element defining at least one zone (2) of capsule facing the flow upstream, preferentially also a zone (3) of capsule facing the flow downstream, and defining an interior volume containing at least one aromatic substance, for obtaining a beverage by means of its crossing by a pressurized fluid flow. The capsules (1, 1') further include at least one controlled opening element (5) retained in an initial position (A) of closing, by means of at least one removable union with a corresponding element fixture (6) provided in each case in the zone (2) of capsule facing the flow upstream and/or in the zone (3) of capsule facing the flow downstream.

[0032] Figures 3a - 3b illustrate a first set of embodiments of a capsule (1, 1') according to the invention.

[0033] Figures 2a - 2b correspond to controlled opening elements (5) disposed in zone (2) facing the flow upstream (Figure 2a) and zone (3) facing the flow downstream (Figure 2b). Capsule (1) presents in this case a controlled opening element (5e) disposed in a respective element fixture (6e) in zone (2) facing the flow upstream (Figure 2a), and/or a controlled opening element (5s) disposed in a respective element fixture (6s) in zone (3) facing the flow downstream (Figure 2b). The controlled opening element (5e, 5s) is in each case retained in a removable manner, preferentially by means of friction union or by means of a positive locking, in a respective element fixture (6e, 6s) provided in the construction element in the zone (2, 3) facing upstream/ downstream. This removable retention is previously dimensioned so

that only by applying a certain actuation force (F) upon the controlled opening element (5), the latter being displaced from the initial position (A) of retention to a following position (B) of retention, thereby releasing at least one certain section of flow passageway allowing the pressurized flow of fluid to pass to a zone of flow downstream.

[0034] In Figure 2a, the controlled opening element (5e) is configured in a substantially tubular and/or conic form, preferentially of substantially circular cross-section, presenting a plurality of passageways (9e) preferentially disposed in the proximity of the extremity facing the flow downstream, preferentially distributed uniformly along the perimeter of said extremity. The respective element fixture (6e) is provided as a support of displacement with such an extension that allows releasing said passageways (9e) by means of applying a certain actuation force (F) upon the controlled opening element (5e).

[0035] In Figure 2b, the section of flow passage is defined by passageways (9s) provided in the controlled opening element (5s), together with passageways (9s') provided in the respective element fixture (6s). Alternatively, or additionally, the section of flow passage might be provided by means of a liquid permeable material and/or with filtering effect. The element fixture (6s) is in this case provided as a re-entrance in the construction element on the side facing the flow downstream, preferentially with a substantially tubular format and so that the controlled opening element (5s) may be displaced along at least part thereof. The section of flow passage is released when the respective passageways (9s, 9s') are substantially aligned with each other. This position preferentially corresponds to a following position (B) of retention of the controlled open element (5s).

[0036] Figures 3a - 3b show a capsule (1) according to the invention in which the controlled opening elements (5e, 5s) are displaced from a initial position (A) of closing (Figure 3a) to a final position (B) of opening (Figure 3b). As one can recognize from the detail drawings 01 and 02, represented below, representing the top zone (2) of the capsule (1), the passageways (9) are completely obstructed when in an initial position (A) of closing. The capsule (1) is closed in an airtight manner. Thus, the passageways (9) may only be un-obstructed by means of displacement of the controlled opening element (5e, 5s) at least to an open position (B). This solution presents several advantages, notably in terms of reducing the pressure loss of the pressurized flow of fluid as it enters the capsule (1), and of a better initial distribution/ dispersion of the flow within the volume of aromatic substance being crossed. Both of these aspects contribute in a substantial way to a bigger efficacy of extraction.

[0037] Figures 4a and 4b represent, in each case in an initial position of closing (top drawing) and in a following position of opening (bottom drawing), a controlled opening element (5) which substantially defines the interior volume of the capsule (1, 1') and the element fixture (6) which works as structural reinforcement element and as blocking/ releasing of at least one section of flow pas-

sageway (in this case defined by a plurality of passageways (9e, 9s) provided at least in the controlled opening element (5)). By way of illustrative example, as it results from the drawings, said section of passageway is released by means of the application of, for example, two actuation forces (F), eventually of approximate dimension, in opposite directions, upon respective element fixture (6e, 6s) that as a result are displaced (while the controlled opening element (5) is kept immobilized), thereby releasing passageways (9e, 9s) (Figure 4a), or by means of the application of at least one actuation force (A) upon the controlled opening element (5) (while the element fixtures (6e, 6s) are kept immobilized), thereby releasing passageways (9e, 9e'; 9s) of flow entry and exit (Figure 4b).

[0038] Figures 5a - 5b schematically represent another preferred embodiment of the capsule (1) according to the invention, in an initial position (Figure 5a) and in a following position of release of a section of flow passageway (Figure 5b), and respective details of the side facing the flow upstream (P01) and downstream (P02). In this case, the controlled opening element (5) is configured as a female type element, for example of ring configuration, and not provided with a section of flow passageway, that is initially retained in a removable manner in an element fixture (6) configured in a corresponding manner as male type element, for example of tubular form, and provided in the construction element of the zone (2, 3) facing upstream/ downstream. The female type element (5) is dimensioned and provided so that it gets retained in positive locking, or in friction union, as for example in a fitting under pressure, in the male type element (6). This male type element presents passageways (9) that are thereby initially obstructed by the female type element, notably when the latter is in an initial situation (A). By means of applying a certain actuation force (F), the female type element (5e, 5s) is displaced since said initial situation (A) of closing to a final situation (B) of opening in which it un-obstructs said passageways (9).

[0039] Figures 6a - 6b illustrate embodiments with the option of control upon the instant when the section of passage is released and upon the dimension of the latter. Thus, according to another preferred embodiment of the invention (Figure 6a), the section of flow passage provided in the opening element (5) and/or in a respective element fixture (6) is only released by means of applying two successive actuation forces (F_1 , F_2). According to another embodiment (Figure 6b), the section of flow passage includes at least two sub-sections disposed so that a first subsection (e.g., first level of flow ways (9) - see detail 01) is released with the displacement of the controlled opening element (5) from a position of retention, to a second, and a second subsection of passage (e.g., second level of passageways (9')) is released with the displacement from said second position of retention to a following position of retention.

[0040] The same construction of capsule (1) may thus be used for different types of aromatic substances, only

requiring varying the configuration of the controlled opening element (5), notably in terms of dimension and instant of releasing the section of passage, that is, for example, of the passageways and/or type of liquid permeable material and/or with filtering effect.

[0041] Figures 7a - 7b illustrate an initial position and a following position, respectively, of a preferred embodiment of the controlled opening element in a capsule according to the invention, regarded as particularly advantageous to induce a certain flow pattern when said capsule (1) is processed in a position in which the pressurized flow flows along a substantially horizontal direction. In particular, the section of flow passage is configured with an asymmetric format (in the present case, illustrated as a way of example, through the passageways (9e, 9s) of different dimension and configuration), previously defined so as to induce a flow with bigger screening of the volume occupied by the aromatic substance, for example starting from the inferior zone of controlled opening element (5e) at the entry, and, inversely from the superior zone of the controlled opening element (5s) at the exit of the capsule (1).

[0042] Figures 8a - 8b are schematic representations of an extraction chamber (10) in a device for the processing of a capsule (1, 1') according to the invention, in an initial position (Figure 8a) and in an extraction position (Figure 8b). The capsule (1, 1') is inserted into this extraction chamber (10) so that the zone (2) of capsule facing the flow upstream is oriented to, and preferentially the controlled opening element (5e) is substantially aligned with, a fluid injection (11), whereas the zone (3) facing the flow downstream is oriented to, and preferentially the controlled opening element (5s) is substantially aligned with, a infusion discharge (12). According to a preferred embodiment of the method according to the invention, the capsule (1, 1') is initially fixated by means of mechanical clamping between the fluid injection (11) and the infusion discharge (12) (Figure 8b). By means of this mechanical clamping, an actuation force (F) is exerted by the fluid injection (11) upon the controlled opening element (5e) so that the latter is displaced from its initial position (A) of retention to a following position (B) of retention. In the present case the passageways (9e) are therefore already un-obstructed when the supply of the pressurized flow of processing fluid starts.

[0043] In another preferred embodiment, and by means of a corresponding configuration of the fluid injection (11) and infusion discharge (12), this mechanical actuation force (F_M) may be used to displace both the controlled opening elements (5e, 5s) from a respective initial position (A) of closing to a following position (B) of retention. According to another preferred embodiment, the mechanical actuation force (F_M) exerted at the time of fixating the capsule (1) in the extraction chamber (10), may be complemented by an hydraulic pressure force (F_H), exerted by the pressurized flow of fluid, to carry out at least the displacement of the controlled opening element (5e).

[0044] Figures 9a and 9b illustrate an example by a controlled opening element (5s) retained in a removable manner in the zone (3) facing the flow downstream.

[0045] As it results from the views in cut of Figure 9a, said controlled opening element (5s) is provided with a plurality of passageways (9s), in this case distributed along only part of the perimeter of the former (top drawing). In this case the controlled opening element (5s) is actuated by a movement at least of rotation, preferentially exerted by the fluid injection (11), so that it is displaced in such an extension along a radial direction, until said passageways (9s) coincide with the passageways (9s') provided in the element fixture (5s) (bottom drawing), thus allowing a fluid crossing communication.

[0046] As one may observe in Figure 9b, the radial distribution of passageways (9s, 9s') disposed in the controlled opening element (5s) and infusion discharge (12), may be advantageously defined so that to increasing rotating angles of the latter (12) inside the former (5s), corresponds a bigger resulting dimension of the section of flow passage.

Claims

1. Capsule (1, 1') containing at least one aromatic substance for production of a beverage by means of its crossing by a pressurized fluid flow, built by at least one construction element defining at least one zone (2) of the capsule suitable to face the flow upstream, and a second zone (3) of the capsule suitable to face the flow downstream, said capsule including at least one controlled opening element (5e) retained in a removable manner in a respective element fixture (6e) in the zone (2) suitable to face the flow upstream, said capsule being **characterized in that** at least one controlled opening element (5s) retained in a removable manner in a respective element fixture (6s) in the zone (3) suitable to face the flow downstream, so that by means of applying respectively at least one actuation force upon said respective controlled opening element (5; 5e, 5s), the latter can be displaced from a respective initial position (A) of retention to a respective following position (B) of retention in its respective element fixture (6; 6e, 6s), each said controlled opening element thereby being suitable to release at least one section of flow passageway provided in the controlled opening element (5; 5e, 5s) and/or in the respective element fixture (6; 6e, 6s).
2. Capsule according to claim 1, **characterized in that** the displacement of the controlled opening element (5; 5e, 5s) can be released an increasing section of flow passageway, disposed along the prevailing flow direction and/or along a transverse direction.
3. Capsule according to claim 1 or 2, **characterized in that** each section of flow passageway can be released as a result of a respective linear and/or rotating movement by the controlled opening element (5; 5e, 5s).
4. Capsule according to any of claims 1 to 3, **characterized in that** the section of flow passageway is provided by at least one, preferentially a plurality of passageways (9) and/or by a liquid permeable material, and/or of filtering effect.
5. Capsule according to any of claims 1 to 4, **characterized in that** the controlled opening element (5; 5e, 5s) and/or respective element fixture (6; 6e, 6s) presents several passageways (9e, 9s; 9e', 9s') that can be un-obstructed or can get in fluid communication with each other by means of the displacement of the respective controlled opening element (5; 5e, 5s) from an initial position (A) of retention to a following position (B) of retention.
6. Capsule according to any of claims 1 to 5, **characterized in that** the passageways (9e, 9e') disposed in the zone (2) suitable to face the flow upstream, are provided in a number, distribution, including radial distribution, dimension and spatial orientation such that the pressurized flow of fluid is projected to at least one distance reach, preferentially to at least two distance reaches, along the radial direction of the capsule, and distributed in uniform or substantially asymmetric way relative to the perimeter of the section of flow passageway.
7. Capsule according to any of claims 1 to 6, **characterized in that** the passageways (9e, 9s; 9e', 9s') of the controlled opening element (5e, 5s) and/or respective element fixture (6e, 6s), present a dimension and/or format that varies in each case at least along the respective perimeter.
8. Capsule according to any of claims 1 to 7, **characterized in that** the controlled opening element (5; 5e, 5s) is configured in a substantially tubular form, or in a substantially ring form, preferentially of circular cross section.
9. Capsule according to any of claims 1 to 8, **characterized in that** the extremity of the controlled opening element (5e, 5s) suitable to face the flow upstream is provided open and the extremity suitable to face the flow downstream is provided closed.
10. Capsule according to any of claims 1 to 9, **characterized in that** the controlled opening element (5; 5e, 5s) is disposed in the capsule (1) so as to collect a certain amount of the pressurized flow of fluid in its interior, until being displaced to a following position (B) of retention.

11. Process for operation of a capsule (1) according to any one of claims 1 to 10, comprising the steps:

- introducing a capsule (1, 1') according to any of claims 1 to 9 in an extraction chamber (10),
 - fixating said capsule (1, 1') in the extraction chamber (10), by means of mechanical clamping, preferentially between an infusion head (11) and an infusion discharge (12),
 - injecting a fluid flow, under a previously defined pressure and during a period of time through the infusion head (11),

characterized in that by means of the mechanical clamping of the capsule (1, 1'), the infusion head (11) applies such an actuation force (F) upon the controlled opening element (5e) disposed in the zone (2) facing the flow upstream, that the latter is displaced in a linear and/or rotating movement, from an initial position (A) of retention to a following position (B) of retention in a respective element fixture (6e), thereby releasing at least one certain section of flow passageway provided in the controlled opening element (5; 5e, 5s) and/or in the respective element fixture (6; 6e, 6s).

12. Process according to claim 11, **characterized in that** by means of the mechanical clamping of the capsule (1, 1'), the infusion discharge (12) exerts such an actuation force (F) upon the controlled opening element (5s) disposed in the zone (3) facing the flow downstream, that the latter is displaced in a linear and/or rotating movement, from an initial position (A) of retention to a following position (B) of retention in a respective element fixture (6s).

13. Process according to claims 11 or 12, **characterized in that** after beginning of the flow injection of pressurized fluid, the latter is immediately introduced inside the capsule (1, 1') through the, at least one, passageway (9e; 9e') of the controlled opening element (5e) and/or respective element fixture (6e).

14. Process according to any of claims 11 to 13, **characterized in that** the pressurized fluid flow initially accumulates in a controlled opening element (5s) disposed in a zone (3) facing the flow downstream that way exerting an increasing hydraulic pressure upon said controlled opening element (5s), until reaching in each case a value such that it provokes the displacement of said controlled opening element (5s) disposed in the zone (3) facing the flow downstream from an initial position (A) of retention to a following position (B) of retention.

15. Device for using a capsule (1, 1') according to any one of claims 1 to 10, **characterized in that** it comprises at least one extraction chamber (10) to carry

out the process according to any of claims 11 to 14.

Patentansprüche

1. Kapsel (1, 1') enthaltend mindestens eine aromatische Substanz zur Herstellung eines Getränks durch seine Überquerung durch einen unter Druck stehenden Flüssigkeitsdurchfluss, die von mindestens einem Konstruktionselement hergestellt ist, das mindestens einen Bereich (2) der Kapsel definiert und geeignet ist, stromaufwärts zugewandt zu sein, und einen zweiten Bereich (3) der Kapsel, der geeignet ist, stromabwärts zugewandt zu sein, wobei die genannte Kapsel mindestens ein kontrolliertes Öffnungselement (5e) beinhaltet, das in ausdehnbarer Weise in einer entsprechenden Elementbefestigung (6e) in der Zone (2), das stromaufwärts zugewandt zu sein geeignet ist, gehalten ist, die genannte Kapsel **gekennzeichnet dadurch, dass** mindestens ein kontrolliertes Öffnungselement (5s), das in ausdehnbarer Weise in einer entsprechenden Elementbefestigung (6s) in der Zone (3), die stromabwärts zugewandt zu sein geeignet ist, gehalten ist, dass durch die Anwendung von zumindest einer entsprechenden Antriebskraft auf entsprechend genanntes, kontrolliertes Öffnungselement (5; 5e, 5s), wobei das letzte von einer entsprechenden Retentionsinitialposition (A) zu einer entsprechenden, folgenden Retentionsposition (B) in seinem entsprechenden Befestigungselement (6; 6e, 6s) verlagert sein kann, wobei jedes genannte kontrollierte Öffnungselement somit geeignet ist, zumindest ein Durchflussbereich freizugeben, das im kontrollierten Öffnungsbereich (5; 5e, 5s) und/oder im entsprechenden Befestigungselement (6; 6e, 6s) vorhanden ist.
2. Kapsel nach Anspruch 1, **dadurch gekennzeichnet, dass** die Verlagerung des kontrollierten Öffnungselements (5; 5e, 5s) einen aufsteigenden Durchflussbereich freigeben kann, der entlang der vorherrschenden Strömungsrichtung und/oder entlang der querlaufenden Richtung angeordnet ist.
3. Kapsel nach Anspruch 1 oder 2, **dadurch gekennzeichnet, dass** jeder Abschnitt der Strömungsrichtung durch eine entsprechend linearen und/oder rotierenden Bewegung des kontrollierten Öffnungselementes (5; 5e, 5s) freigegeben werden kann.
4. Kapsel nach einer der Ansprüche 1 bis 3, **dadurch gekennzeichnet, dass** der Abschnitt der Strömungsrichtung durch zumindest einen, bevorzugt von einer Vielheit von Durchflüssen (9) und/oder durch ein flüssig durchlässiges Material und/oder eines Filtereffektes vorgesehen ist.
5. Kapsel nach einer der Ansprüche 1 bis 4, **dadurch**

- gekennzeichnet, dass** das kontrollierte Öffnungselement (5; 5e, 5s) und/oder entsprechendes Befestigungselement (6; 6e, 6s) mehrere Durchflüsse (9e, 9s; 9e', 9s') darstellt, welche unbehindert sein oder in flüssiger Verbindung mit einander stehen können dadurch, dass das entsprechende, kontrollierte Öffnungselement (5; 5e, 5s) von einer entsprechenden Retentionsinitialposition (A) zu einer folgenden Retentionsposition (B) verlagert wird.
6. Kapsel nach einer der Ansprüchen 1 bis 5, **dadurch gekennzeichnet, dass** die Durchflüsse (9e, 9e'), die im Bereich (2), der stromaufwärts zugewandt zu sein geeignet ist, angeordnet sind in Zahlen, Verteilung, einschließlich strahlige Verteilung, Dimension und räumliche Ausrichtung bereitgestellt sind und zwar so, dass der unter Druck stehende Flüssigkeitsdurchfluss an zumindest eine greifbare Entfernung ausgerichtet, bevorzugt an zwei greifbaren Entfernungen, entlang der strahligen Richtung der Kapsel, und in uniformellem oder wesentlich asymmetrischem Weg zum Perimeter des Bereiches der Strömungsrichtung verteilt ist.
7. Kapsel nach einer der Ansprüchen 1 bis 6, **dadurch gekennzeichnet, dass** die Durchflüsse (9e, 9s; 9e', 9s') des kontrollierten Öffnungselementes (5e, 5s) und/oder des entsprechenden Befestigungselementes (6e, 6s) eine Dimension und/oder einen Format darstellen, welche in jedem der Fälle zumindest entlang des entsprechenden Perimeters schwanken.
8. Kapsel nach einer der Ansprüchen 1 bis 7, **dadurch gekennzeichnet, dass** das kontrollierte Öffnungselement (5; 5e, 5s) in einer wesentlich rohrförmigen Form oder in einer wesentlich ringförmigen Form bevorzugt eines kreisförmigen Kreuzbereiches gestaltet ist.
9. Kapsel nach einer der Ansprüchen 1 bis 8, **dadurch gekennzeichnet, dass** die Extremität des kontrollierten Öffnungselementes (5e, 5s) geeignet ist, stromaufwärts zugewandt zu sein, und offen und die Extremität, geeignet, stromabwärts zugewandt zu sein, geschlossen vorhanden ist.
10. Kapsel nach einer der Ansprüchen 1 bis 9, **dadurch gekennzeichnet, dass** das kontrollierte Öffnungselement (5; 5e, 5s) in der Kapsel (1) so angeordnet ist, dass eine bestimmte Menge des unter Druck stehenden Flüssigkeitsdurchflusses in sein Inneres zu sammeln ist, bis es zur folgenden Retentionsposition (B) verlagert wird.
11. Bedienungsverlauf einer Kapsel (1) nach einer der Ansprüchen 1 bis 10 umfassend folgende Schritte:
- Einführung einer Kapsel (1, 1') nach einer der
- Ansprüche 1 bis 9 in einer Extraktionskammer (10),
- Fixierung der genannten Kapsel (1, 1') durch mechanische Einspannung in der Extraktionskammer (10), bevorzugt zwischen einem Infusionskopf (11) und einer Infusionsentladung (12),
 - Einspritzen eines Flüssigkeitsflusses durch des Infusionskopfes unter vordefiniertem Druck und innerhalb eines Zeitraumes (11),
- dadurch gekennzeichnet dass** durch die mechanische Einspannung der Kapsel (1, 1'), der Infusionskopf (11) eine solche Antriebskraft (F) auf das kontrollierte Öffnungselement (5e) im stromaufwärts zugewandten Bereich (2) anwendet, dass das letzte in einer linearen und/oder rotierenden Bewegung von einer Initialretentionsposition (A) zu einer folgenden Retentionsposition (B) in einem entsprechenden Befestigungselement (6e) verlagert ist, wobei somit zumindest ein bestimmtes Bereich des Durchflusses freigegeben ist, der im kontrollierten Öffnungselement (5; 5e, 5s) und/oder im entsprechenden Befestigungselement (6; 6e, 6s) vorhanden ist.
12. Verfahren nach Anspruch 11, **dadurch gekennzeichnet dass** durch die mechanische Einspannung der Kapsel (1, 1'), die Infusionsentladung (12) eine solche Antriebskraft (F) auf das kontrollierte Öffnungselement (5s), das im stromabwärts zugewandten Bereich (3) angeordnet ist, ausübt dass das letzte in einer linearen und/oder rotierenden Bewegung von einer Initialretentionsposition (A) zu einer folgenden Retentionsposition (B) in einem entsprechenden Befestigungselement (6s) verlagert ist.
13. Verfahren nach Ansprüche 11 oder 12, **dadurch gekennzeichnet, dass** nach Beginn der Durchflussinjektion der unter Druck stehenden Flüssigkeit diese sofort innerhalb der Kapsel (1, 1') durch zumindest einen Durchfluss (9e; 9e') des kontrollierten Öffnungselementes (5e) und/oder des entsprechenden Befestigungselementes (6e) eingeführt wird.
14. Verfahren einer der Ansprüchen 11 bis 13, **dadurch gekennzeichnet, dass** die unter Druck stehenden Flüssigkeitsflüsse sich anfangs in einem kontrollierten Öffnungselement (5s) sammelt, das im stromabwärts zugewandten Bereich (3) angeordnet ist, und somit einen aufsteigend hydraulischen Druck auf das genannte kontrollierte Öffnungselement (5s) ausgeübt wird, bis es in jedem der Fälle einen Wert so erreicht, dass es die Verlagerung des genannten kontrollierten Öffnungselementes (5s), das im stromabwärts zugewandten Bereich (3) angeordnet ist, von einer Initialretentionsposition (A) zu einer folgenden Retentionsposition (B) auslöst.

15. Gerät zur Anwendung einer Kapsel (1, 1') nach einer der Ansprüche 1 bis 10, **dadurch gekennzeichnet, dass** es zumindest eine Extraktionskammer (10) umfasst, die den Verfahren nach einer der Ansprüche 11 bis 14 durchführt.

Revendications

1. Capsule (1, 1') contenant au moins une substance aromatique pour la production d'une boisson au moyen de son passage par un flux de fluide sous pression, construit au moins par un élément de construction définissant au moins une zone (2) de la capsule apte à faire face au flux en amont, et une deuxième zone (3) de la capsule apte à faire face au flux en aval, la dite capsule comprenant au moins un élément d'ouverture contrôlée (5e) retenu de façon amovible au respectif élément de fixation (6e) sur la zone (2) apte à faire face au flux en amont, la dite capsule **caractérisée en ce qu'** au moins un élément d'ouverture contrôlée (5s) retenu de façon amovible au respectif élément de fixation (6s) sur la zone (3) apte à faire face au flux en aval, **en ce que** par l'application respectivement d'au moins une force d'actionnement sur le dit respectif élément d'ouverture contrôlée (5; 5e, 5s), celui-ci pouvant se déplacer de sa respective position initiale (A) de rétention vers une respective position suivante (B) de rétention dans l'élément respectif de fixation (6; 6e, 6s), de chaque dit élément d'ouverture contrôlée ainsi adapté pour libérer au moins une section de passage de flux prévu sur l'élément d'ouverture contrôlée (5; 5e, 5s) et/ou dans le respectif élément de fixation (6; 6e, 6s).
2. Capsule selon la revendication 1, **caractérisée en ce que** le déplacement de l'élément d'ouverture contrôlée (5; 5e, 5s) peut libérer une section croissante de flux, disposé le long de la direction dominante de flux et/ou le long de la direction transversale.
3. Capsule selon la revendication 1 ou 2, **caractérisée en ce que** chaque section de passage du flux peut être libérée comme résultat d'un mouvement respectif linéaire et/ou rotatif par l'élément d'ouverture contrôlée (5; 5e, 5s).
4. Capsule selon l'une quelconque des revendications 1 à 3, **caractérisée en ce que** la section de passage du flux est fournie par au moins un, de préférence une pluralité de passages (9) et/ou par un matériau perméable aux liquides, et/ou de l'effet de filtrage.
5. Capsule selon l'une quelconque des revendications 1 à 4, **caractérisée en ce que** l'élément d'ouverture contrôlée (5; 5e, 5s) et/ou le respectif élément de fixation (6; 6e, 6s) présente plusieurs passages (9e,

9s; 9e', 9s') pouvant être non obstrués ou pouvant entrer en communication de fluide avec l'autre par le déplacement du respectif élément d'ouverture contrôlée (5; 5e, 5s) d'une position initiale (A) de rétention vers une position suivante (B) de rétention.

6. Capsule selon l'une quelconque des revendications 1 à 5, **caractérisée en ce que** les passages (9e, 9e') disposés sur la zone (2) apte à faire face au flux en amont, sont fournis dans un certain nombre, la distribution, y compris la distribution radiale, la dimension et l'orientation spatiale de telle sorte que le flux de fluide sous pression est projeté au moins à une distance de portée, de préférence au moins à deux distances de portée, le long de la direction radiale de la capsule, et distribués uniformément ou de manière sensiblement asymétrique par rapport au périmètre de la section de passage du flux.
7. Capsule selon l'une quelconque des revendications 1 à 6, **caractérisée en ce que** les passages (9e, 9s; 9e', 9s') de l'élément d'ouverture contrôlée (5e, 5s) et/ou le respectif élément de fixation (6e, 6s) présentent une dimension et/ou un format qui varie en chaque cas au moins le long du périmètre respectif.
8. Capsule selon l'une quelconque des revendications 1 à 7, **caractérisée en ce que** l'élément d'ouverture contrôlée (5; 5e, 5s) est configuré sous une forme sensiblement tubulaire, ou sensiblement sous une forme d'anneau, préférentiellement de section transversale circulaire.
9. Capsule selon l'une quelconque des revendications 1 à 8, **caractérisée en ce que** l'extrémité de l'élément d'ouverture contrôlée (5e, 5s) apte à faire face au flux en amont est prévu ouverte et l'extrémité apte à faire face au flux en aval est prévu fermée.
10. Capsule selon l'une quelconque des revendications 1 à 9, **caractérisée en ce que** l'élément d'ouverture contrôlée (5; 5e, 5s) est disposé dans la capsule (1) de manière à recueillir une certaine quantité de flux du fluide sous pression dans sa partie intérieure, avant d'être déplacé vers une position suivante (B) de rétention.
11. Procédé de fonctionnement d'une capsule (1) selon l'une quelconque des revendications 1 à 10, en comprenant les étapes :
- introduction de la capsule (1, 1') selon l'une quelconque des revendications 1 à 9 dans une chambre d'extraction (10),
 - fixation de la dite capsule (1, 1') dans la chambre d'extraction (10) par un serrage mécanique, préférentiellement entre une tête d'infusion (11) et une décharge d'infusion (12),

- injection d'un flux de fluide, sous une pression préalablement définie et pendant une période de temps à travers la tête d'infusion (11),
caractérisé en ce que par un serrage mécanique de la capsule (1, 1'), la tête d'infusion (11) utilise une telle force d'actionnement (F) sur l'élément d'ouverture contrôlée (5e) disposé sur la zone (2) en faisant face au flux en amont, tel que celui-ci est déplacé dans un mouvement linéaire et/ou de rotation, d'une position initiale (A) de rétention vers une position suivante (B) de rétention sur le respectif élément de fixation (6e), libérant ainsi au moins une certaine section de passage du flux prévu dans l'élément d'ouverture contrôlée (5; 5e, 5s) et/ou, dans le respectif élément de fixation (6; 6e, 6s).
- 5
10
15
12. Procédé selon la revendication 11, **caractérisé en ce que** par un serrage mécanique de la capsule (1, 1'), la décharge d'infusion (12) exerce une telle force d'actionnement (F) sur l'élément d'ouverture contrôlée (5s) disposé sur la zone (3) faisant face au flux en aval, tel que celui-ci est déplacé dans un mouvement linéaire et/ou rotatif, d'une position initiale (A) de rétention vers une position suivante (B) de rétention sur son élément respectif de fixation (6s).
- 20
25
13. Procédé selon les revendications 11 ou 12, **caractérisé en ce qu'**après le début de l'injection de flux sous pression, celui-ci est tout de suite introduit à l'intérieur de la capsule (1, 1') à travers, au moins, d'un passage (9e ; 9e') de l'élément d'ouverture contrôlée (5e) et/ou du respectif élément de fixation (6e).
- 30
14. Procédé selon l'une quelconque des revendications 11 à 13, **caractérisé en ce que** le flux du fluide sous pression accumule d'abord dans l'élément d'ouverture contrôlée (5s) disposé sur une zone (3) en faisant face au flux en aval, de cette façon exerce une pression hydraulique croissante sur le dit élément d'ouverture contrôlée (5s), jusqu'à atteindre dans ce cas une valeur telle qu'elle provoque le déplacement du dit élément d'ouverture contrôlée (5s) disposé sur la zone (3) en faisant face au flux en aval, d'une position initial (A) de rétention vers une position suivante (B) de rétention.
- 35
40
45
15. Dispositif pour l'utilisation d'une capsule (1, 1') selon l'une quelconque des revendications 1 à 10, **caractérisé en ce qu'**il comprend au moins une chambre d'extraction (10) pour réaliser le procédé selon l'une quelconque des revendications 11 à 14.
- 50

55

Figura 1a



Figura 1b



Figura 2a

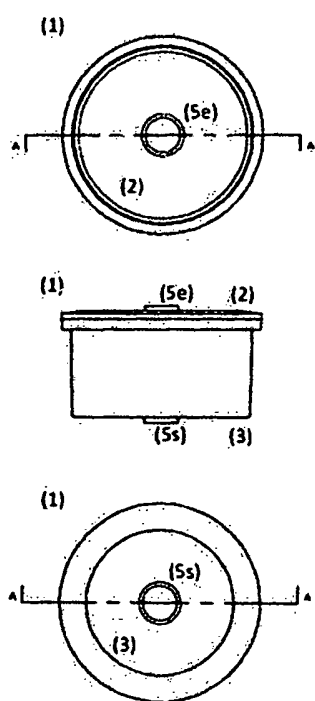

Figura 2b

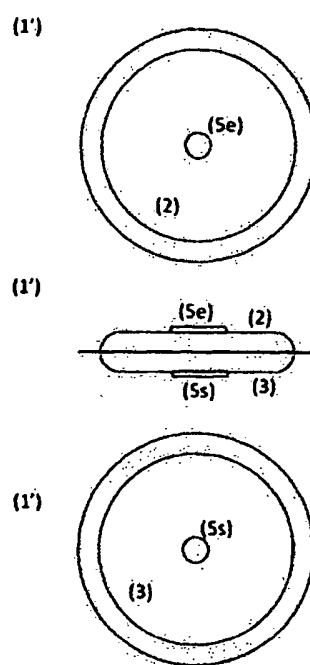

Figura 3a

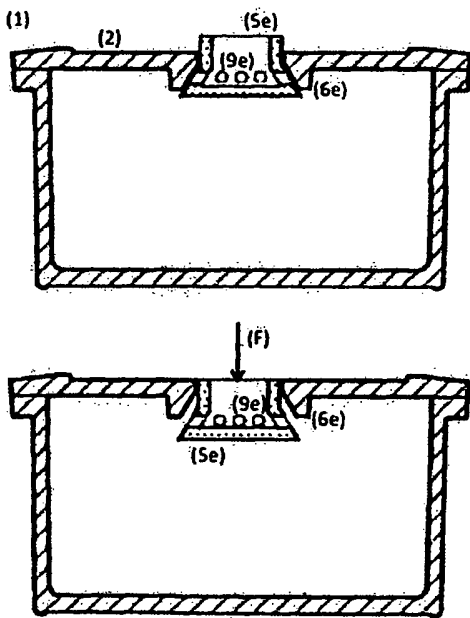

Figura 3b

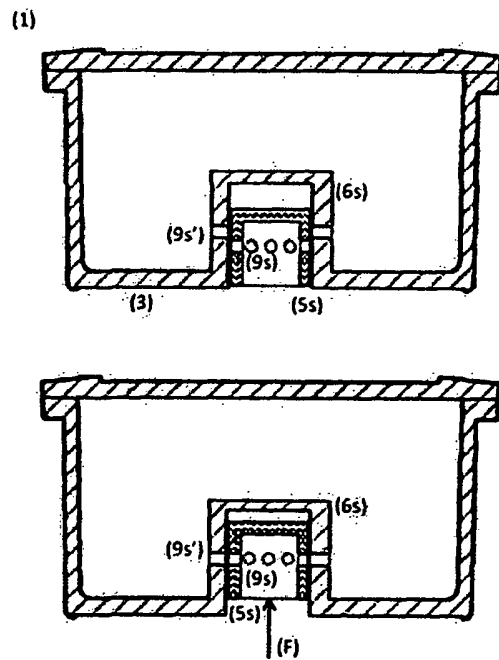

Figura 3a - P01

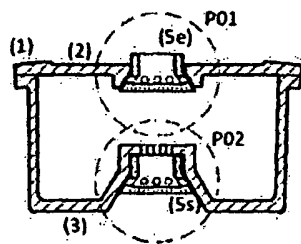

Figura 3b - P01

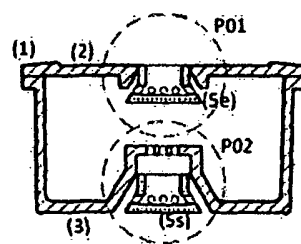

Figura 3a - P02

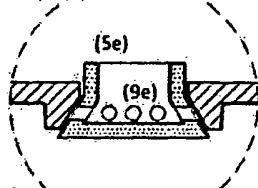

Figura 3b - P02

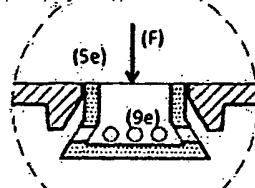

Figura 4a

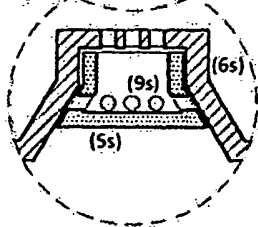

Figura 4b

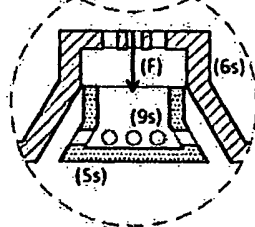

Figura 5a

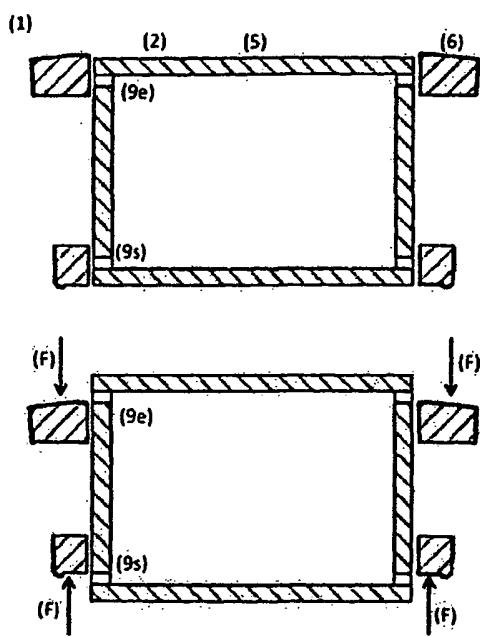

Figura 5b

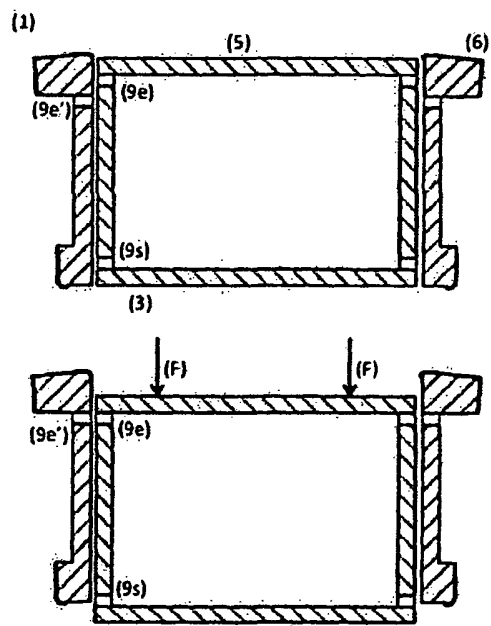

Figura 5a - P01

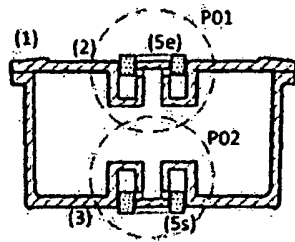

Figura 5b - P01

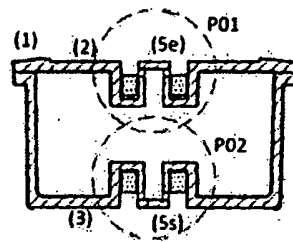

Figura 5a - P02

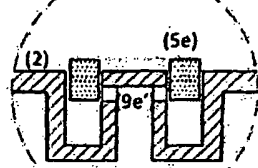

Figura 5b - P02

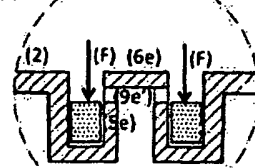

Figura 6a

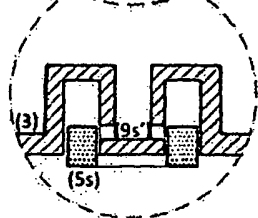

Figura 6b

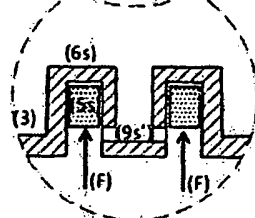

Figura 7a

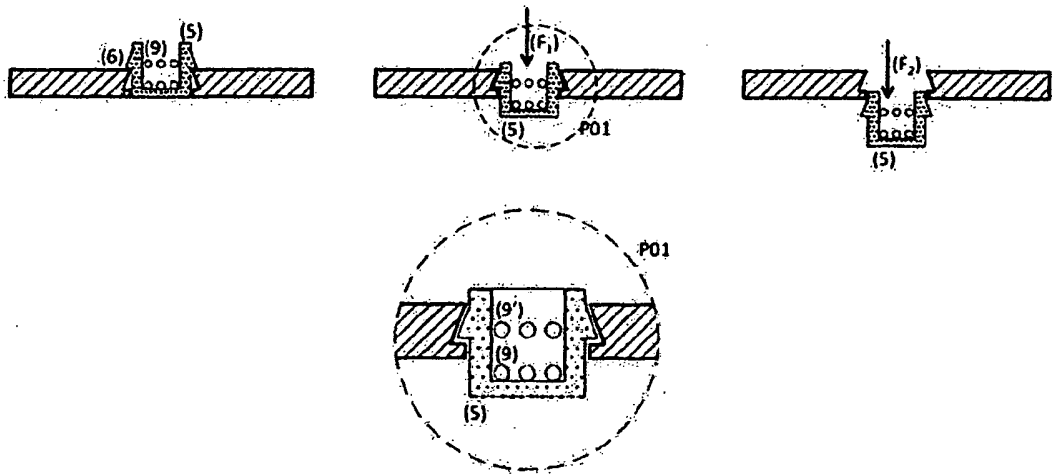

Figura 7b

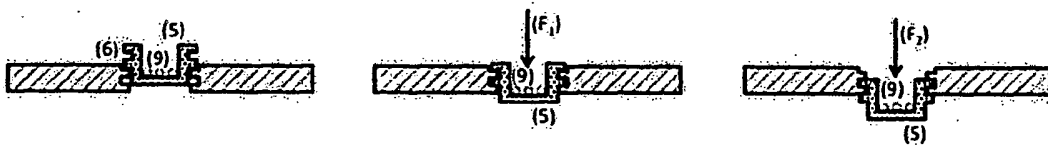

Figura 8a

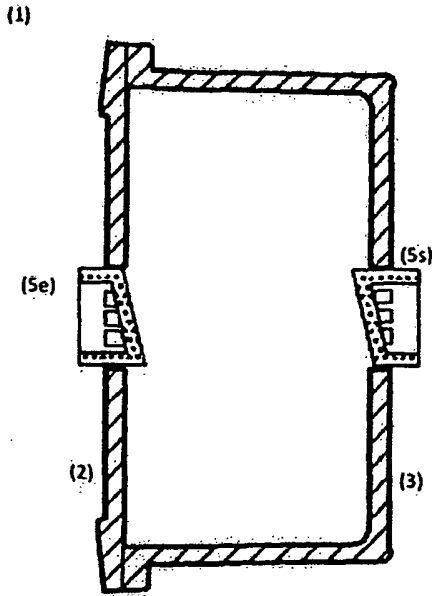

Figura 8b

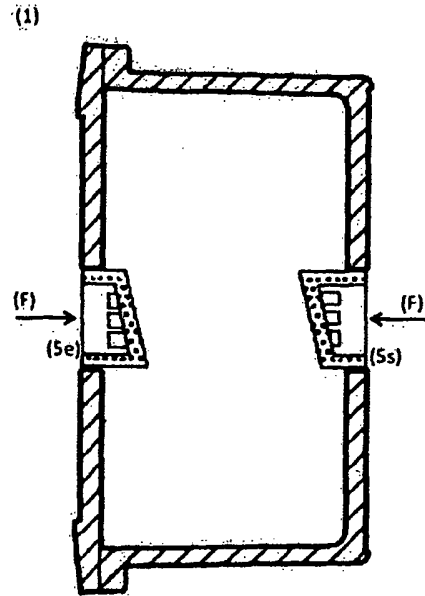

Figura 9a

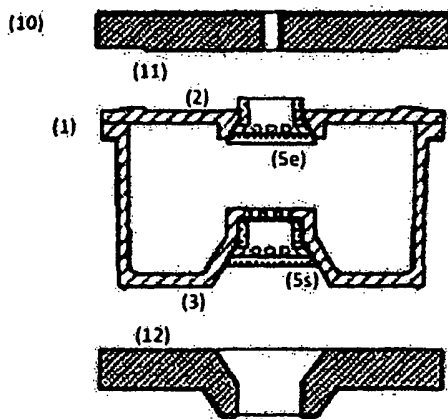

Figura 9b

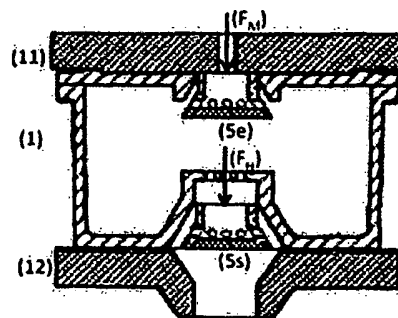

REFERENCES CITED IN THE DESCRIPTION

This list of references cited by the applicant is for the reader's convenience only. It does not form part of the European patent document. Even though great care has been taken in compiling the references, errors or omissions cannot be excluded and the EPO disclaims all liability in this regard.

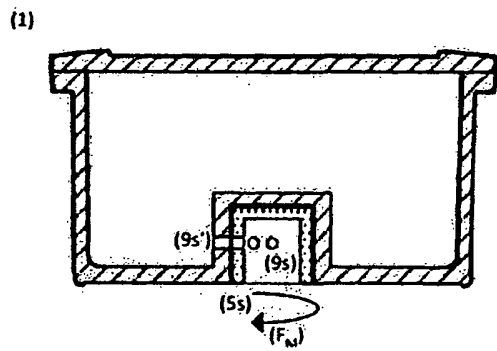
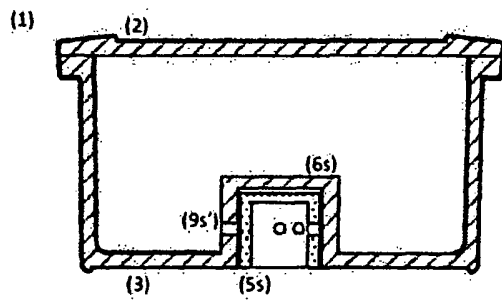
Patent documents cited in the description

- WO 2008087099 A2 [0006]
- WO 2005020769 A1 [0006]
- EP 1243210 A1 [0006]
- EP 1826148 B1 [0006]
- EP 2210826 A1 [0007]
- US 2008028946 A1 [0007]

Szabadalmi igénypontok

1. Kapszula (1, 1'), melyben túlnyomásos fluidum átbocsátásával történő italkészítéshez legalább egy aromás anyag van elrendezve, amely kapszula a kapszula áramlásiránnyal szembe néző legalább egy tartományát (2) és a kapszula áramlásirányba néző második tartományát (3) meghatározó legalább egy szerkezeti elemként van kialakítva, ahol a kapszula az áramlásiránnyal szembe néző tartományában (2) neki megfelelő elemfoglatban (6e) elmozdíthatón megtartott vezérelt nyílóelemmel (5e) rendelkezik, azzal jellemezve, hogy az áramlásirányba néző tartományban (3) legalább egy vezérelt nyílóelem (5s) olyan módon van neki megfelelő elemfoglatban (6s) elmozdíthatón megtartva, hogy a megfelelő vezérelt nyílóelemre (5; 5e, 5s) legalább egy működtető erőt kifejtve a tekintett nyílóelem a neki megfelelő elemfoglatban (6; 6e, 6s) egy kezdeti visszatartó helyzetből (A) egy megfelelő következő visszatartó helyzetbe (B) mozgatható, miáltal valamennyi vezérelt nyílóelem a vezérelt nyílóelemben (5; 5e, 5s) és/vagy a neki megfelelő elemfoglatban (6; 6e, 6s) lévő áramlási járat legalább egy része szabaddá tételére alkalmas.
2. Az 1. igénypont szerinti kapszula, azzal jellemezve, hogy a vezérelt nyílóelem (5; 5e, 5s) elmozdításával a fennálló áramlásirány mentén és/vagy keresztirányban az áramlási járat növekvő része tehető szabaddá.
3. Az 1. vagy a 2. igénypont szerinti kapszula, azzal jellemezve, hogy a vezérelt nyílóelem (5; 5e, 5s) lineáris és/vagy rotációs mozgásának eredményeként az áramlási járat teljes keresztmetszetében szabaddá tehető.
4. Az 1-3. igénypontok bármelyike szerinti kapszula, azzal jellemezve, hogy az áramlási járatot legalább egy, előnyösen több járat (9) és/vagy folyadékáteresztő anyag és/vagy szűrőellenállás képezi.
5. Az 1-4. igénypontok bármelyike szerinti kapszula, azzal jellemezve, hogy a vezérelt nyílóelem (5; 5e, 5s) és/vagy a neki megfelelő elemfoglat (6; 6e, 6s) néhány, a megfelelő vezérelt nyílóelemet (5; 5e, 5s) a kezdeti visszatartó helyzetből (A) a következő visszatartó helyzetbe (B) mozgatva akadálymentesíthető vagy egymással közlekedővé váló járattal (9e, 9s; 9e', 9s') rendelkezik.

6. Az 1-5. igénypontok bármelyike szerinti kapszula, azzal jellemezve, hogy az áramlásiránnyal szembe néző tartományban (2) lévő áramlási járatok (9e, 9e') olyan számban, kiosztásban, beleértve a sugárirányú kiosztást is, méretben és térbeli orientációban vannak kiképezve, hogy a túlnyomásos fluidumáramot a kapszula sugáriránya mentén legalább egy adott távolságba, előnyösen legalább két adott távolságba juttatják el, továbbá az áramlási járat keresztmetszete kerületéhez egyenletesen vagy lényegében aszimmetrikusan osztják el.
7. Az 1-6. igénypontok bármelyike szerinti kapszula, azzal jellemezve, hogy a vezérelt nyílóelem (5e, 5s) és/vagy a neki megfelelő elemfogalat (6e, 6s) járatai (9e, 9s; 9e', 9s') legalább a hozzátartozó kerület mentén minden esetben változó méretűek és/vagy alakúak.
8. Az 1-7. igénypontok bármelyike szerinti kapszula, azzal jellemezve, hogy a vezérelt nyílóelem (5; 5e, 5s) lényegében cső alakú vagy lényegében gyűrű alakú, és előnyösen kör keresztmetszetű.
9. Az 1-8. igénypontok bármelyike szerinti kapszula, azzal jellemezve, hogy a vezérelt nyílóelem (5e, 5s) áramlásiránnyal szembe néző végei nyitottak, és az áramlásirányba néző végei zártak.
10. Az 1-9. igénypontok bármelyike szerinti kapszula, azzal jellemezve, hogy a vezérelt nyílóelem (5; 5e, 5s) a következő visszatartó helyzetbe (B) mozgatásáig a belsejében adott mennyiségű túlnyomásos fluidumot összegyűjtően van a kapszulában (1) elhelyezve.
11. Eljárás az 1-10. igénypontok bármelyike szerinti kapszula (1) működtetésére, amelynél
- egy az 1-9. igénypontok bármelyike szerinti kapszulát (1, 1') extrahálókamrában (10) helyezünk el,
 - a kapszulát (1, 1') az extrahálókamrában (10) mechanikailag befogva előnyösen forrázófej (11) és főzetelvezetés (12) közé rögzítjük,
 - a forrázófejen (11) keresztül előre meghatározott nyomáson és időtartamon át fluidumáramot fecskendezünk be,
- azzal jellemezve, hogy a kapszula (1, 1') mechanikai befogása révén a forrázófej (11) az áramlásiránnyal szembe néző tartományban (2) lévő vezérelt nyílóelemre (5e) olyan működtető erőt (F) fejt ki, hogy a nyílóelem a neki megfelelő elemfogalatban (6e) lineáris és/vagy rotációs mozgással egy kezdeti visszatartó helyzetből (A) egy következő

visszatartó helyzetbe (B) mozdul el, miáltal a vezérelt nyílóelemben (5; 5e, 5s) és/vagy a megfelelő elemfoglatban (6; 6e, 6s) lévő áramlási járatok legalább egy meghatározott tartománya szabaddá válik.

12. A 11. igénypont szerinti eljárás, azzal jellemezve, hogy a kapszula (1, 1') mechanikai befogása révén a főzetelvezetés (12) az áramlásirányba néző tartományban (3) lévő vezérelt nyílóelemre (5s) olyan működtető erőt (F) fejt ki, hogy a nyílóelem a neki megfelelő elemfoglatban (6s) lineáris és/vagy rotációs mozgással egy kezdeti visszatartó helyzetből (A) egy következő visszatartó helyzetbe (B) mozdul el.

13. A 11. vagy a 12. igénypont szerinti eljárás, azzal jellemezve, hogy a túlnyomásos fluidumáram befecskendezésének megkezdését követően a túlnyomásos fluidumáram a vezérelt nyílóelemben (5e) és/vagy a neki megfelelő elemfoglatban (6e) lévő legalább egy járaton (9e; 9e') keresztül azonnal a kapszula (1, 1') belsejébe jut.

14. A 11-13. igénypontok bármelyike szerinti eljárás, azzal jellemezve, hogy a túlnyomásos fluidumáram kezdetben egy az áramlásirányba néző tartományban (3) lévő vezérelt nyílóelemben (5s) gyűlik össze és ezáltal a vezérelt nyílóelemre (5s) növekvő nagyságú folyadéknymást fejt ki egészen addig, míg egy az áramlásirányba néző tartományban (3) lévő vezérelt nyílóelem (5s) kezdeti visszatartó helyzetből (A) következő visszatartó helyzetbe (B) történő elmozdulását kiváltó értéket el nem ér.

15. Eszköz az 1-10. igénypontok bármelyike szerinti kapszula (1, 1') használatára, azzal jellemezve, hogy a 11-14. igénypontok bármelyike szerinti eljárás foganatosításához legalább egy extrahálókamrát (10) tartalmaz.