



(12) **EUROPEAN PATENT APPLICATION**

(88) Date of publication A3:  
**09.07.2008 Bulletin 2008/28**

(51) Int Cl.:  
**B65D 35/08 (2006.01)** **B65D 35/38 (2006.01)**  
**B65D 35/42 (2006.01)** **B65D 35/44 (2006.01)**

(43) Date of publication A2:  
**31.10.2007 Bulletin 2007/44**

(21) Application number: **07014869.7**

(22) Date of filing: **15.12.2003**

(84) Designated Contracting States:  
**AT BE BG CH CY CZ DE DK EE ES FI FR GB GR HU IE IT LI LU MC NL PT RO SE SI SK TR**  
 Designated Extension States:  
**AL LT LV MK**

(71) Applicant: **Bormioli Rocco & Figlio S.p.A.**  
**43036 Fidenza (Parma) (IT)**

(72) Inventor: **Morini, Emilio**  
**43052 Colorno (Parma) (IT)**

(62) Document number(s) of the earlier application(s) in accordance with Art. 76 EPC:  
**03786204.2 / 1 694 573**

(74) Representative: **Gotra, Stefano**  
**BUGNION S.p.A.**  
**Via Vellani Marchi, 20**  
**41100 Modena (IT)**

(54) **An improved tube made of a plastic material**

(57) The tube exhibits a lower part (1a), which is open for introduction of a product and closable after the introduction, and an upper part (1b) which exhibits a passage-hole (2) for exit of the product from the tube. The upper

part (1b) comprises an opening (3), which is larger than the passage-hole (2) and arranged in a zone of the upper part (1b) in which the passage-hole (2) is to be made. A reducer element (4) sealingly fits in the opening (3) and exhibits the passage-hole (2).

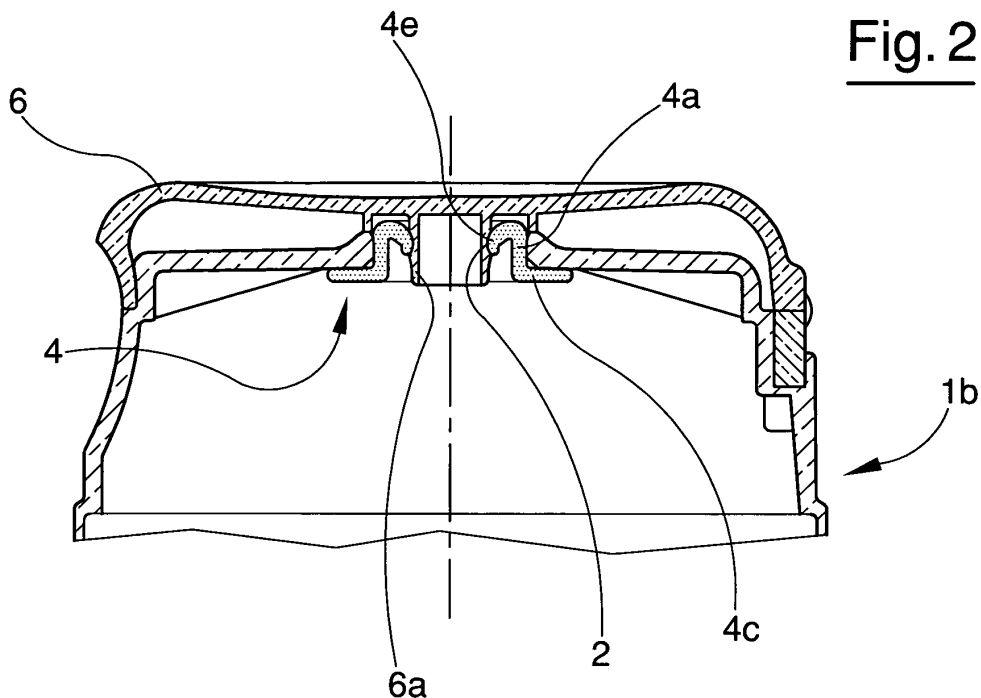

**Fig. 2**



DOCUMENTS CONSIDERED TO BE RELEVANT			
Category	Citation of document with indication, where appropriate, of relevant passages	Relevant to claim	CLASSIFICATION OF THE APPLICATION (IPC)
X	GB 847 947 A (BRITISH XYLONITE CO LTD) 14 September 1960 (1960-09-14)	1-4	INV. B65D35/08 B65D35/38 B65D35/42 B65D35/44
Y	* page 1, line 8 - page 3, line 116 * * figures 1-3 *	5-7	
Y	----- WO 03/099544 A (NORDEN TUBES AB [SE]; JOENSSON SVEN-AAKE [SE]; SCHOETTLI AG [CH]; SCHO) 4 December 2003 (2003-12-04) * page 1, line 5 - line 25 * * page 7, line 19 - page 12, line 22 * * figures 1-6 *	5-7	
A	----- FR 778 193 A (MÖLLER) 11 March 1935 (1935-03-11) * page 1, line 1 - page 2, line 96 * * figures 1,2 *	1	
The present search report has been drawn up for all claims			TECHNICAL FIELDS SEARCHED (IPC)
			B65D
Place of search		Date of completion of the search	Examiner
Munich		29 May 2008	Rodriguez Gombau, F
CATEGORY OF CITED DOCUMENTS		T : theory or principle underlying the invention E : earlier patent document, but published on, or after the filing date D : document cited in the application L : document cited for other reasons ..... & : member of the same patent family, corresponding document	
X : particularly relevant if taken alone Y : particularly relevant if combined with another document of the same category A : technological background O : non-written disclosure P : intermediate document			

3  
EPC FORM 1503 03.82 (F04C01)

**ANNEX TO THE EUROPEAN SEARCH REPORT  
ON EUROPEAN PATENT APPLICATION NO.**

EP 07 01 4869

This annex lists the patent family members relating to the patent documents cited in the above-mentioned European search report. The members are as contained in the European Patent Office EDP file on The European Patent Office is in no way liable for these particulars which are merely given for the purpose of information.

29-05-2008

Patent document cited in search report		Publication date	Patent family member(s)	Publication date
GB 847947	A	14-09-1960	NONE	
-----				
WO 03099544	A	04-12-2003	AU 2003244273 A1	12-12-2003
			EP 1523405 A1	20-04-2005
			SE 522156 C2	20-01-2004
			SE 0201572 A	28-11-2003
-----				
FR 778193	A	11-03-1935	NONE	
-----				

EPO FORM P0489

For more details about this annex : see Official Journal of the European Patent Office, No. 12/82