



(11) **EP 2 247 514 B1**

(12) **EUROPEAN PATENT SPECIFICATION**

(45) Date of publication and mention of the grant of the patent:
14.12.2011 Bulletin 2011/50

(21) Application number: **09703848.3**

(22) Date of filing: **20.01.2009**

(51) Int Cl.:
B65D 85/10^(2006.01) B65D 5/66^(2006.01)

(86) International application number:
PCT/EP2009/000318

(87) International publication number:
WO 2009/092559 (30.07.2009 Gazette 2009/31)

(54) **HINGE LID CONTAINER**
KLAPPDECKELBEHÄLTER
CONTENANT À COUVERCLE ARTICULÉ

(84) Designated Contracting States:
AT BE BG CH CY CZ DE DK EE ES FI FR GB GR HR HU IE IS IT LI LT LU LV MC MK MT NL NO PL PT RO SE SI SK TR
Designated Extension States:
RS

(30) Priority: **21.01.2008 EP 08250259**

(43) Date of publication of application:
10.11.2010 Bulletin 2010/45

(73) Proprietor: **Philip Morris Products S.A.**
2000 Neuchâtel (CH)

(72) Inventors:
• **LUTZIG, Bodo, W.**
1373 Chavornay (CH)
• **SNYDER, Tony**
1052 Le Mont-sur-Lausanne (CH)

(74) Representative: **Taylor, Gillian Claire**
Reddie & Grose
16 Theobalds Road
London WC1X 8PL (GB)

(56) References cited:
DE-B- 1 054 373 DE-U1- 7 826 336
US-A- 2 872 097 US-A- 4 923 059
US-B1- 6 527 166

EP 2 247 514 B1

Note: Within nine months of the publication of the mention of the grant of the European patent in the European Patent Bulletin, any person may give notice to the European Patent Office of opposition to that patent, in accordance with the Implementing Regulations. Notice of opposition shall not be deemed to have been filed until the opposition fee has been paid. (Art. 99(1) European Patent Convention).

Description

[0001] The present invention relates to a novel hinge lid container, which finds particular application as a container for elongate smoking articles such as cigarettes.

[0002] It is known to package elongate smoking articles and other consumer goods in containers formed from folded laminar blanks. Elongate smoking articles, such as cigarettes and cigars, are commonly sold in hinge lid packs having a box portion for housing the smoking articles and a lid portion connected to the box portion about a hinge line extending across the rear wall of the container. Such packs are typically constructed from one-piece laminar cardboard blanks. In use, the lid portion is pivoted about the hinge line to open the pack and so gain access to the smoking articles held in the box portion.

[0003] Graphics and text are typically applied to the exterior of packaging for consumer goods in order to communicate information to the consumer. However, standard hinge lid cigarette packs are relatively small in size and have a limited visible exterior surface area for displaying such information. It is known for manufacturers to try to increase the amount of information communicated to the consumer on hinge lid cigarette packs by providing additional surfaces on which the information may be printed. This has been achieved, for example, by incorporating additional panels, or coupons into the container. Such panels and coupons may be integral to the container, or alternatively may be incorporated separately within the container.

[0004] It has also been proposed to provide hinge lid packs for smoking articles having an increased internal surface area for the printing of indicia and graphics. For example, WO-A-03/078274 discloses a hinge lid pack for smoking articles wherein an increased internal surface area is provided by means of an inner frame and alternatively or in addition, by means of the inward facing surface of the front wall of the lid. DE 1054373 discloses a hinge lid pack having the features of the preamble of claim 1, in which the part wall of the lid has an increased height so that it overlaps with the box front wall in the closed position of the lid. US 4923059 also discloses a hinge lid pack with a lid front wall of increased height US 6527 166 discloses a hinge lid pack having a cut out in the box front wall so that the front wall of the inner frame is visible in the closed position of the lid.

[0005] It would be desirable to provide a hinge lid container for smoking articles that has a greater internal surface area for the display of consumer information than typical hinge lid cigarette packs, without substantially increasing the overall size of the container, or the amount of material required to manufacture it. In addition, it would be desirable to provide a hinge lid container for smoking articles having a larger, uninterrupted space for the display of consumer information on the lid portion of the container. It would also be desirable to provide such a hinge lid container without compromising on the strength or rigidity of the container.

[0006] It would further be desirable to provide a novel hinge lid container having a greater internal surface area, but which can be produced with minimal or no modification to existing packaging machinery.

[0007] According to the present invention there is provided a container having a front wall, a rear wall and opposed side walls extending therebetween, the container comprising: a box portion; and a lid portion hinged to the box portion along a hinge line extending across the rear wall of the container, wherein at each side wall of the container, the angle ϕ between the front edge of the side wall of the lid portion and the lower edge thereof is greater than the acute angle θ defined between the rear edge of the side wall and a straight line extending between a first point ("point A") where the hinge line meets the side wall and a second point ("point B") where the upper edge of a front wall of the box portion meets the side wall. When the container is closed the free edges of the lid portion abut the free edges of the box portion such that the line of abutment extending between the first point A and the second point B comprises a first linear portion extending between the front edge and the opposed rear edge of the side wall and a second linear portion extending along the front edge of the side wall of the container, from the second point B to the point where the first linear portion meets the front wall of the container.

[0008] Containers according to the invention find particular application as packs for smoking articles, such as cigarettes.

[0009] Preferably, the angle ϕ is at least 10 degrees greater than the angle θ , more preferably at least 15 degrees. Preferably, the angle ϕ is between 45 degrees and 90 degrees, more preferably between 60 degrees and 90 degrees.

[0010] Preferably, the angle θ is less than 60 degrees, more preferably between 35 degrees and 60 degrees and particularly preferably between 35 degrees and 45 degrees.

[0011] The terms "front", "rear", "upper", "lower", "side" and other terms used to describe relative positions of the components of containers according to the invention refer to the container in an upright position. When the container in the upright position is open, the smoking articles contained in the box portion may be removed from the upper end of the container.

[0012] The term "hinge line" refers to a line about which the lid portion may be pivoted in order to open the container. A hinge line may be, for example, a fold line or a score line in the panel forming the rear wall of the container. Alternatively, a hinge line may be a fold line or a score line in a piece of material connecting the rear wall of the lid portion to the rear wall of the box portion. Such a piece of material may be, for example, a label that is permanently or removably attached to the rear wall of the lid portion and the rear wall of the box portion. Preferably, the hinge line is positioned along the rear or side wall of the container, at a level below the upper edge thereof.

[0013] The term "linear" is used herein to describe a substantially straight line.

[0014] Typically, in a standard hinge lid cigarette pack, the straight line extending between point A and point B, as defined above, coincides with the straight line of abutment in the side wall of the container along which the lower edges of the side walls of the lid portion abut the upper edges of the side walls of the box portion. The line of abutment is therefore also at an angle of θ to the rear edge of the side wall of the container. In a typical hinge lid cigarette pack, the angle θ is approximately 60 degrees.

[0015] Throughout the present specification, the term "line of abutment" is used to describe the line along which the free edges of the walls of the lid portion of a container according to the present invention abut the free edges of the walls of the box portion when the container is closed.

[0016] In a typical hinge lid cigarette pack, the angle θ and the angle ϕ are substantially the same as each other, both being approximately 60 degrees. In contrast, in containers according to the invention, the angle ϕ is greater than the angle θ , preferably by at least 10 degrees. The difference in these angles is achieved through the provision of a line of abutment having first and second linear portions between point A and point B, wherein the first and second linear portions extend at different angles to each other. The line of abutment may include one or more additional linear portions, as described below. For example, in certain embodiments of the present invention, the line of abutment further comprises a third linear portion extending from the first point A along the rear edge of the side wall of the container.

[0017] Preferably, the angle θ in containers according to the present invention is less than 60 degrees and thereby smaller than that of a standard hinge lid pack. By decreasing the angle θ of containers according to the invention below 60 degrees, it is possible to obtain containers with a lid portion having a longer front wall than is typically provided in hinge lid cigarette packs. The "length of the front wall is considered to be the vertical height of the wall when the container is upright and in a closed position.

[0018] The exterior surface area of containers according to the invention may not necessarily be greater than the exterior surface area of a typical hinge lid cigarette pack. However, the surface area of the front wall of the lid portion of containers according to the invention is greater than in a typical hinge lid cigarette pack. Therefore, a greater internal surface area becomes visible to the consumer when the lid portion is opened. This internal surface area includes, for example, the surfaces of the inner frame (if present), the surfaces of any other packaging of the smoking articles within the container, and the internal surfaces of the lid portion. Additional consumer information may be provided on this additional internal surface area, which becomes visible when the lid portion is opened. Furthermore, the surface area of the

front face of the lid portion is greater than that of a standard hinge lid pack. Therefore a greater, uninterrupted space for consumer information is provided on the lid portion.

5 **[0019]** Preferably, in containers according to the present invention, the ratio of the length of the front wall of the lid portion to the length of the front wall of the box portion is above 35:65, which is the ratio of these lengths in a typical hinge lid cigarette pack.

10 **[0020]** Although it may be desirable to maximize the angle θ in order to increase the visible internal surface area of containers according to the invention, it is also preferable if the angle ϕ is as high as possible. This is because the larger the angle ϕ , the stronger and more durable the lower portion of the side walls of the lid portion become. Furthermore, the larger the angle ϕ , the more rigid the lower section of the lid portion becomes.

15 **[0021]** It is particularly preferable if the angle α defined between the line of abutment extending across the side wall of the container and the rear edge of the side wall of the box portion of the container is also maximized. By increasing the angle α , the increased strength and durability described above with reference to the angle ϕ are also obtained for the upper portion of the side walls of the box portion. Depending on the shape of the line of abutment between point A and point B, the angle α may be the same as, or different to the angle ϕ .

20 **[0022]** The present invention provides containers in which the form of the line of abutment between point A and point B may be varied such that the angle θ can be kept relatively low, whilst the angles ϕ and α can be similar to, or greater than the corresponding angles in a known hinge lid packs. The strength and rigidity of containers according to the invention need not, therefore, be compromised in order to obtain the greater internal surface area.

25 **[0023]** If desired, the corner at which the first linear portion meets the second linear portion may be bevelled, or rounded.

30 **[0024]** Preferably, each side wall of the container is formed from an inner wall and an overlying outer wall. The line of abutment extending along the inner wall between point A and point B may be different to, or the same as the line of abutment extending along the outer wall. Preferably, the line of abutment extending along the inner wall between point A and point B is the same shape as the line of abutment extending along the outer wall, but is vertically offset therefrom. A vertical offset may, advantageously, be employed to strengthen the rear wall of the box portion and the front wall of the lid portion.

35 **[0025]** The line of abutment between the lower edge of the front wall of the lid portion and the upper edge of the front wall of the box portion is preferably a straight, substantially horizontal line. The front wall of the box portion may include a cut out at the upper edge thereof to expose the inner packaging underneath. Alternatively, or in addition, the front wall of the lid portion may include a cut out at the lower edge thereof. Where a cut out is

provided, there will typically be no abutment of the lower edge of the lid portion with the upper edge of the box portion and the line of abutment will therefore be broken. The provision of a cut out may assist the consumer in opening the lid portion.

[0026] Preferably, the container further comprises an inner frame mounted within the box portion, wherein the inner frame extends above the upper edges of at least the front wall of the box portion of the container. The inner frame is therefore visible to the consumer when the lid portion is opened. The front wall of the inner frame may be printed with indicia which may be the same as, or different to the indicia printed on the front wall of the box portion. Alternatively, or in addition, the front wall of the inner frame may be cut into a distinctive shape, for example, to reflect the branding of the consumer goods.

[0027] Preferably, the front wall of the inner frame is provided with a cut out portion at the upper edge thereof. This enables more convenient access to the consumer goods within the container, without significantly reducing the surface area of the front wall of the inner frame.

[0028] Alternatively, or in addition to an inner frame, the smoking articles within the container may be wrapped with a printed wrapper, which is visible above the upper edge of the front wall of the box portion and the front wall of the inner frame (if present) when the container is open.

[0029] Advantageously, it is possible to produce containers according to the invention using existing machinery which has been only slightly modified to take into account the different length of the front face of the lid portion. The only fold which is required to be in a different position to a standard hinge lid pack is that along the lower edge of the front face of the lid portion.

[0030] Containers according to the invention may be substantially rectangular parallelepipedal in shape, with right-angled longitudinal and right-angled transverse edges. Alternatively, the box portion or the lid portion or both the box portion and the lid portion of containers according to the invention may comprise one or more rounded longitudinal edges, rounded transverse edges, bevelled longitudinal edges or bevelled transverse edges, or combinations thereof. For example, by scoring in a known manner a laminar blank from which the box portion and the lid portion of the container are erected, a "rounded-corner" pack of cigarettes or other smoking articles according to the invention may be produced.

[0031] The container may be formed from any suitable materials including, but not limited to, cardboard, paperboard, plastic, metal, or combinations thereof. Preferably, the container is formed from a single folded laminar blank, more preferably from a folded laminar cardboard blank. Preferably, the cardboard has a weight of between about 100 grams per square metre and about 350 grams per square metre.

[0032] Containers according to the invention find particular application as packs for elongate smoking articles such as, for example, cigarettes, cigars or cigarillos. It will be appreciated that through appropriate choices of

the dimensions thereof, containers according to the invention may be designed for different numbers of conventional size, king size, super-king size, slim or super-slim cigarettes.

[0033] Through an appropriate choice of the dimensions thereof, containers according to the invention may also be designed to hold different total numbers of smoking articles, or different arrangements of smoking articles. For example, through an appropriate choice of the dimensions thereof, containers according to the invention may be designed to hold a total of ten, fifteen, sixteen, seventeen, eighteen, nineteen, twenty, twenty-one or twenty five smoking articles. These may be arranged in different collations, depending on the total number of smoking articles. For example, the smoking articles may be arranged in one row of six, seven, eight, nine or ten; two rows of five, six, seven, eight, nine or ten; three rows of 5-5-5, 5-6-5, 6-5-6, 5-6-7, 6-7-6, 7-5-7, 7-6-7, 7-7-7, 8-9-8; four rows of four, five or six.

[0034] The length, width and depth of containers according to the invention may be such that, in the closed position, the resultant overall dimensions of the container are similar to the dimensions of a typical disposable hinge-lid pack of twenty cigarettes.

[0035] The exterior surfaces of containers according to the invention may be printed, embossed, debossed or otherwise embellished with manufacturer or brand logos, trade marks, slogans and other consumer information and indicia.

[0036] Where the box portion of a container according to the present invention contains a bundle of cigarettes or other elongate smoking articles, the smoking articles are preferably wrapped in an inner liner of, for example, metal foil or metallised paper.

[0037] Once filled, containers according to the invention may be shrink wrapped or otherwise over wrapped with a transparent polymeric film of, for example, polyethylene or polypropylene in a conventional manner. Where containers according to the invention are over wrapped, the over wrapper may include a tear tape. The tear tape is preferably positioned around the container below the lower edge of the front wall of the lid portion, such that once the tear tape has been removed, the lid portion is free to be rotated about the hinge line. Alternatively, the tear tape may be provided lengthways around the container.

[0038] The invention will be further described, by way of example only, with reference to the accompanying drawings in which:

Figures 1 and 2 show front perspective views of open hinge lid containers according to first and second embodiments of the present invention, respectively; and
 Figures 1a and 2a show a schematic partial side view of the containers of respective Figures 1 and 2, illustrating the angles ϕ , θ and α . The line of abutment

between A and B is shown in Figures 1a and 2a as a bold line. Figures 1a and 2a are not drawn to scale.

[0039] The hinge lid container 30 shown in Figure 1 is a rectangular parallelepiped and comprises a lower box portion 32 and an upper lid portion 34 that is hinged to the lower box portion 32 along a hinge line extending substantially horizontally along the rear wall of the container. The level of the hinge line is indicated in Figure 1 at point "A".

[0040] The box portion 32 has a front wall 36, a left side wall 38, a right side wall, a rear wall, and a bottom wall. The side walls of the box portion extend above the front wall thereof so that the upper free edges of the side walls are offset from the upper free edge of the front wall.

[0041] The lid portion 34 has a front wall 36a, a left side wall 38a, a right side wall, a rear wall and an upper wall. The front wall 36a of the lid portion 34 extends beyond the side walls 38a thereof so that the lower edge of the front wall 36a is offset from the lower edges of the side walls 38a. The offset corresponds to the offset between the upper free edges of the front wall 36 and side walls 38 of the box portion 32.

[0042] When the container 30 is closed, the free edges of the walls of the lid portion 34 abut the free edges of the corresponding walls of the box portion 32 along a line of abutment. In the closed position the walls of the lid portion 34 therefore form extensions of the corresponding walls of the box portion 32 to define the walls of the container 30.

[0043] As shown in Figures 1 and 1a, the line of abutment between the point A and the point B consists of two connected straight line portions. As defined above, point A is where the hinge line meets the side wall of the container and point B is where the upper edge of the front wall 36 of the box portion 32 meets the side wall. A first portion 42 extends from point A along the side wall of the container to the front edge thereof, at an angle of approximately 60 degrees to the rear edge of the side wall. This angle corresponds to angle α . A second portion 44 extends from the end of the first portion 42 downwardly along the front edge of the side wall of the container to point B. The angle θ in the container 10 is approximately 45 degrees, while the angle ϕ is approximately 60 degrees. The angle ϕ is therefore substantially the same as the angle α . The line of abutment between point A and point B is shown in bold in Figure 1a.

[0044] The ratio of the length of the front wall 36a of the lid portion 34 to the length of the front wall 36 of the box portion 32 is approximately 40:60. The front wall 38a of the lid portion 34 is longer relative to the overall length of the container 30 than the front wall of the lid portion of a typical hinge lid cigarette pack.

[0045] The box portion 32 and the lid portion 34 are formed together from a single cardboard blank. Each of the opposed side walls of the box portion 32 and the lid portion 34 are formed from an inner panel and an outer panel, affixed to the inner panel. The inner panel of each

side wall is substantially the same size and shape as the respective outer panel. As can be seen from Figure 1, the panels directly overlies each other with their free edges substantially aligned, such that the inner wall is barely visible.

[0046] An inner cardboard frame 20 is mounted in the box portion 32 against the inner walls thereof. The inner frame is formed from a separate cardboard blank to the box portion 32 and the lid portion 34 and has a front wall, a left side wall and a right side wall. The front wall includes a cut out at the upper edge thereof, so that the articles within the container can be more easily removed. The walls of the inner frame 20 extend above the upper edges of the front 36 and side 38 walls of the box portion into space covered by the lid portion 34 when the container 30 is closed. The frictional engagement between the inner frame 20 and the inner walls of the lid portion 34 ensures that the lid portion 34 remains in a closed position until a positive force is applied in order to open the container by pivoting the lid portion 34 about the hinge line. The frictional engagement may be reinforced by the provision of retention means on the inner frame 20, which engage with the inner walls of the lid portion 34.

[0047] The hinge lid container 50 shown in Figure 2 is of a similar construction to that shown in Figure 1 and described above. However, unlike in the container 30 shown in Figure 1, the line of abutment extending between points A and B includes three linear portions in a Z-shape, as described below. In addition, the inner and outer panels of the side walls of both the lid portion 54 and the box portion 52 are of a different length to each other.

[0048] As shown in Figure 2a, the line of abutment between the point A and the point B consists of three connected straight line portions. A first portion 72 extends from a point a small distance below point A along the side wall of the container to the front edge thereof, at an angle of approximately 60 degrees to the rear edge of the side wall. This angle corresponds to angle α . A second portion 74 extends from the end of the first portion 72 downwardly along the front edge of the side wall of the container to point B. A third portion 76 extends from the opposite end of the first portion 72 upwardly along the rear edge of the side wall of the container to point A. The three linear portions thereby form a Z-shaped line of abutment. The angle θ in the container 50 is less than 45 degrees while the angle ϕ is approximately 60 degrees. The angle ϕ is therefore substantially the same as the angle α . The line of abutment between point A and point B is shown in bold in Figure 2a.

[0049] As can be seen in Figure 2, the inner panels 60 of the side walls 58 of the box portion 52 extend above the outer panels 62 thereof so that the upper free edges of the inner panel 60 and the outer panel 62 are offset from each other. The upper free edge of the inner panel 60 is parallel to the upper free edge of the outer panel 62 and meets the hinge line at the rear edge of the side wall of the container. The portion of the inner panel 60

extending above the outer panel 62 strengthens the portion of the rear wall of the box portion between the upper free edge of the outer panel 62 and the hinge line.

[0050] Conversely, the outer panels of the side walls 58a of the lid portion 54 extend below the inner panels thereof so that the lower free edges of the inner panel and the outer panel are offset from each other. The lower free edges of the inner panel are indicated by a dashed line in Figure 2. The offset in the lid portion 54 corresponds to the offset in the box portion 52, so that when the container 50 is closed the lower edges of the panels of each side wall 58a of the lid portion abut the upper edges of the corresponding panels 60,62 of the side walls 58 of the box portion 52.

Claims

1. A container (30), (50) having a front wall, a rear wall and opposed side walls extending therebetween, the container comprising:

a box portion (32), (52); and
a lid portion (34), (54) hinged to the box portion (32), (52) along a hinge line extending across a rear wall of the container (30), (50),

wherein at each side wall of the container, the angle ϕ between the front edge of the side wall (38a), (58a) of the lid portion (34), (54) and the lower edge thereof is greater than the angle θ defined between the rear edge of the side wall and a straight line extending between a first point (A) where the hinge line meets the side wall and a second point (B) where the upper edge of a front wall (36), (56) of the box portion (32), (52) meets the side wall; and

wherein, when the container (30), (50) is closed, the free edges of the lid portion (34), (54) abut the free edges of the box portion (32), (52) such that the line of abutment extending between the first point A and the second point B comprises a first linear portion (42), (72) extending between the front edge and the opposed rear edge of the side wall and **characterised in that** the line of abutment extending between the first point A and the second point B further comprises a second linear portion (44), (74) extending along the front edge of the side wall of the container (30), (50), from the second point B to the point where the first linear portion (42), (72) meets the front wall of the container (30), (50).

2. A container 30), (50) according to claim 1 wherein the angle ϕ is at least 10 degrees greater than the angle θ .
3. A container (30), (50) according to claim 1 or 2 wherein the angle θ is between 35 degrees and 60

degrees.

4. A container (50) according to claim 1 wherein the line of abutment further comprises a third linear portion (76) extending from the first point A along the rear edge of the side wall of the container to the point where the first linear portion (72) meets the rear wall of the container (50).
5. A container (30), (50) according to any preceding claim wherein the ratio of the length of the front wall (36a), (56a) of the lid portion (34), (54) to the length of the front wall (36), (56) of the box portion (32), (52) is greater than 35:65.
6. A container (50) according to any preceding claim wherein each side wall of the container is formed from an inner wall and an outer wall and wherein the line of abutment extending along the inner wall between the first point A and the second point B is different to the line of abutment extending along the outer wall.

25 Patentansprüche

1. Behälter (30) (50) mit einer vorderen Wand, einer Rückwand und dazwischen verlaufenden, einander gegenüberliegenden Seitenwänden, wobei der Behälter Folgendes umfasst:

einen Schachtelteil (32) (52) und
einen Deckelteil (34) (54), der entlang einer Gelenklinie, die über eine Rückwand des Behälters (30) (50) verläuft, an den Schachtelteil (32) (52) angelenkt ist,

wobei an jeder Seitenwand des Behälters der Winkel \square zwischen der Vorderkante der Seitenwand (38a) (58a) des Deckelteils (34) (54) und der Unterkante davon größer als der Winkel θ ist, der zwischen der hinteren Kante der Seitenwand und einer Geraden definiert wird, die zwischen einem ersten Punkt (A), wo die Gelenklinie auf die Seitenwand trifft, und einem zweiten Punkt (B), wo die Oberkante einer vorderen Wand (36) (56) des Schachtelteils (32) (52) auf die Seitenwand trifft, verläuft, und

wobei, wenn der Behälter (30) (50) geschlossen ist, die freien Kanten des Deckelteils (34) (54) an die freien Kanten des Schachtelteils (32) (52) stoßen, so dass die Stoßlinie, die zwischen dem ersten Punkt A und dem zweiten Punkt B verläuft, einen ersten linearen Abschnitt (42) (72) aufweist, der zwischen der Vorderkante und der gegenüberliegenden hinteren Kante der Seitenwand verläuft, und **dadurch gekennzeichnet, dass** die Stoßlinie, die zwischen dem ersten Punkt A und dem zweiten Punkt B verläuft, fer-

- ner einen zweiten linearen Abschnitt (44) (74) aufweist, der entlang der Vorderkante der Seitenwand des Behälters (30) (50) von dem zweiten Punkt B zu dem Punkt verläuft, wo der erste lineare Abschnitt (42) (72) auf die vordere Wand des Behälters (30) (50) trifft.
2. Behälter (30) (50) nach Anspruch 1, wobei der Winkel \square wenigstens 10 Grad größer als der Winkel θ ist.
 3. Behälter (30) (50) nach Anspruch 1 oder 2, wobei der Winkel θ zwischen 35 Grad und 60 Grad beträgt.
 4. Behälter (50) nach Anspruch 1, wobei die Stoßlinie ferner einen dritten linearen Abschnitt (76) aufweist, der von dem ersten Punkt A entlang der hinteren Kante der Seitenwand des Behälters zu dem Punkt verläuft, wo der erste lineare Abschnitt (72) auf die Rückwand des Behälters (50) trifft.
 5. Behälter (30) (50) nach einem der vorhergehenden Ansprüche, wobei das Verhältnis der Länge der vorderen Wand (36a) (56a) des Schachtelteils (34) (54) zu der Länge der vorderen Wand (36) (56) des Deckelteils (32) (52) größer als 35:65 ist.
 6. Behälter (50) nach einem der vorhergehenden Ansprüche, wobei jede Seitenwand des Behälters von einer inneren Wand und einer äußeren Wand gebildet wird und wobei die Stoßlinie, die entlang der inneren Wand zwischen dem ersten Punkt A und dem zweiten Punkt B verläuft, anders ist als die Stoßlinie, die entlang der äußeren Wand verläuft.
- Revendications**
1. Contenant (30), (50) comportant une paroi frontale, une paroi arrière et s'étendant entre elles des parois latérales opposées, le contenant comprenant :
 - une partie de boîte (32), (52), et
 - une partie de couvercle (34), (54) articulée sur la partie de boîte (32), (52) le long d'une ligne d'articulation s'étendant en travers d'une paroi arrière du contenant (30) (50),
 - dans lequel au niveau de chaque paroi latérale du contenant, l'angle ϕ entre le bord frontal de la paroi latérale (38a), (58a) de la partie de couvercle (34), (54) et son bord inférieur est supérieur à l'angle θ défini entre le bord arrière de la paroi latérale et une droite s'étendant entre un premier point (A) où la ligne d'articulation rencontre la paroi latérale et un second point (B) où le bord supérieur d'une paroi frontale (36), (56) de la partie de boîte (32), (52) rencontre la paroi latérale ; et
 - dans lequel, quand le contenant (30), (50) est fermé, les bords libres de la partie de couvercle (34), (54) buttent contre les bords libres de la partie de boîte (32), (52) de telle sorte que la ligne de butée s'étendant entre le premier point A et le second point B comprenne une première partie linéaire (42), (72) s'étendant entre le bord frontal et le bord arrière opposé de la paroi latérale et **caractérisé en ce que** la ligne de butée s'étendant entre le premier point A et le second point B comprend en outre une seconde partie linéaire (44), (74) s'étendant le long du bord avant de la paroi latérale du contenant (30) (50), depuis le second point B jusqu'au point où la première partie linéaire (42), (72) rencontre la paroi frontale du contenant (30), (50).
 2. Contenant (30), (50) selon la revendication 1, dans lequel l'angle ϕ est supérieur audit angle θ par au moins 10 degrés.
 3. Contenant (30), (50) selon la revendication 1 ou 2, dans lequel l'angle θ est compris entre 35 et 60 degrés.
 4. Contenant (50) selon la revendication 1, dans lequel la ligne de butée comprend en outre une troisième partie linéaire (76) s'étendant depuis le premier point A le long du bord arrière de la paroi latérale du contenant jusqu'au point où la première partie linéaire (72) rencontre la paroi arrière du contenant (50).
 5. Contenant (30), (50) selon l'une quelconque des revendications précédentes, dans lequel le rapport de la longueur de la paroi frontale (36a), (56a) de la partie de couvercle (34), (54) sur la longueur de la paroi frontale (36a), (56a) de la partie de couvercle (32), (52) est supérieur à 35:65.
 6. Contenant (50) selon l'une quelconque des revendications précédentes, dans lequel chaque paroi latérale du contenant est formée par une paroi interne et une paroi externe et dans lequel la ligne de butée s'étendant le long de la paroi interne entre le premier point A et le second point B est différente de la ligne de butée s'étendant le long de la paroi externe.

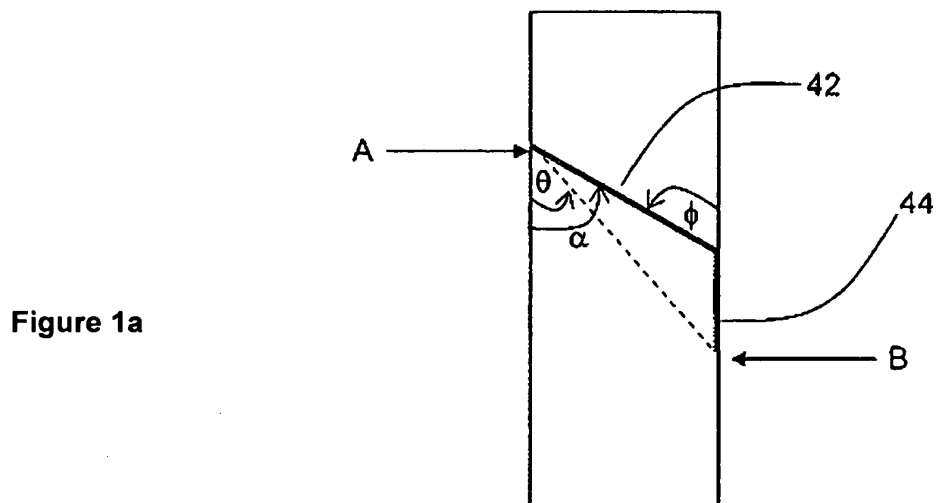
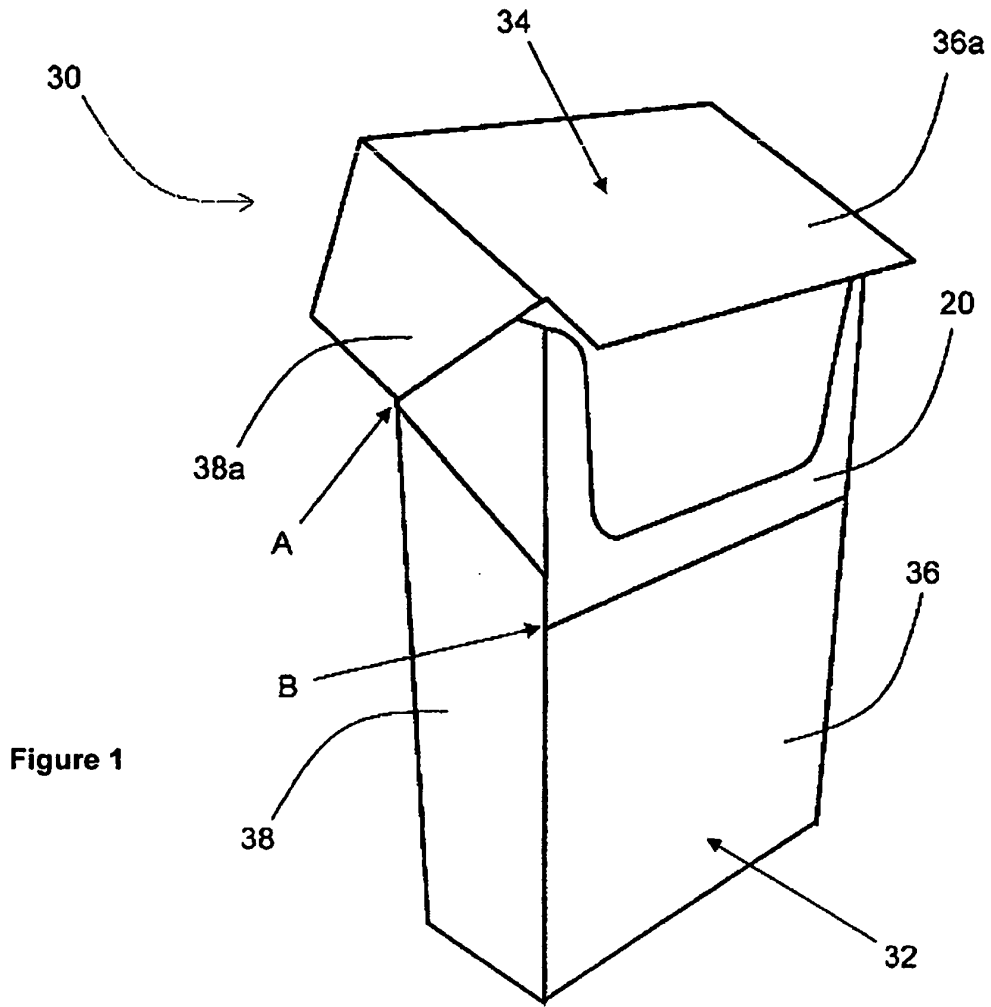

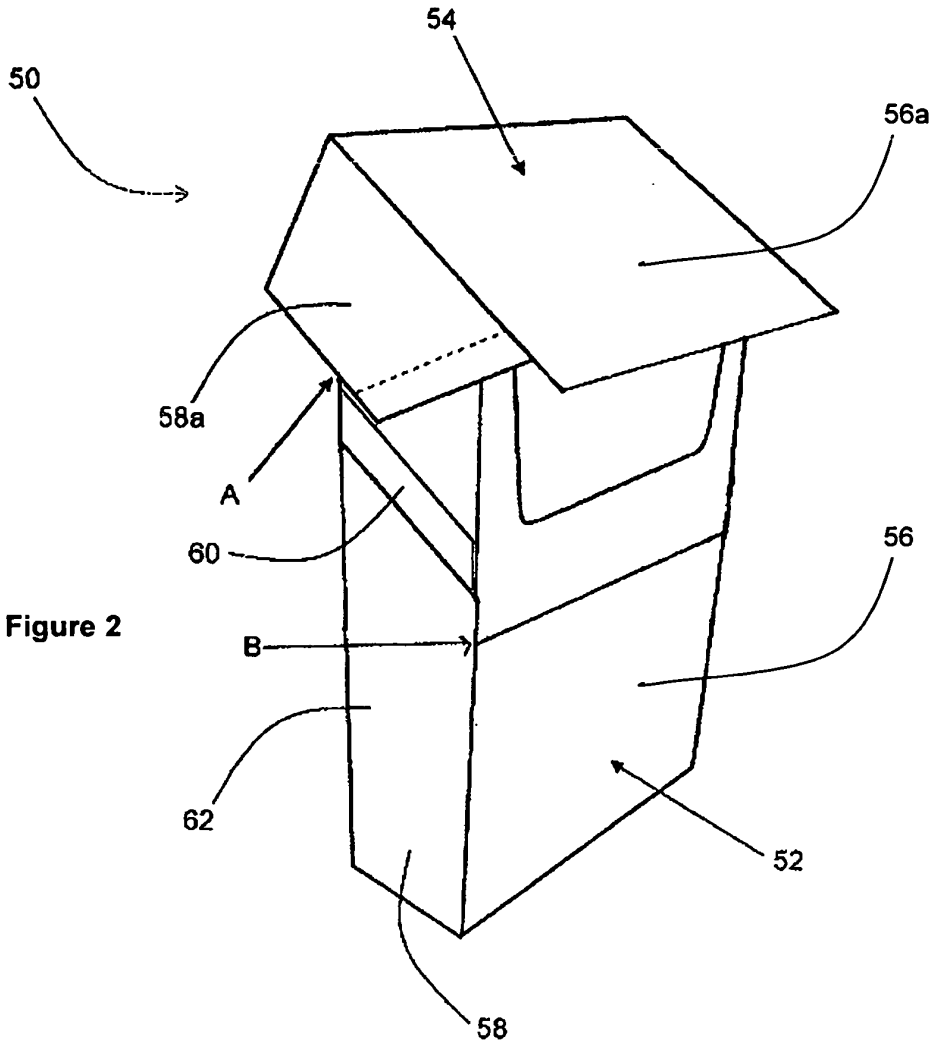
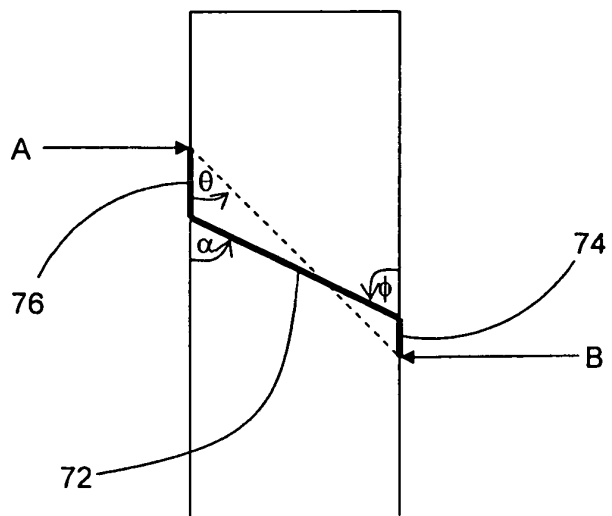

Figure 2a



REFERENCES CITED IN THE DESCRIPTION

This list of references cited by the applicant is for the reader's convenience only. It does not form part of the European patent document. Even though great care has been taken in compiling the references, errors or omissions cannot be excluded and the EPO disclaims all liability in this regard.

Patent documents cited in the description

- WO 03078274 A [0004]
- US 4923059 A [0004]
- US 6527166 B [0004]