

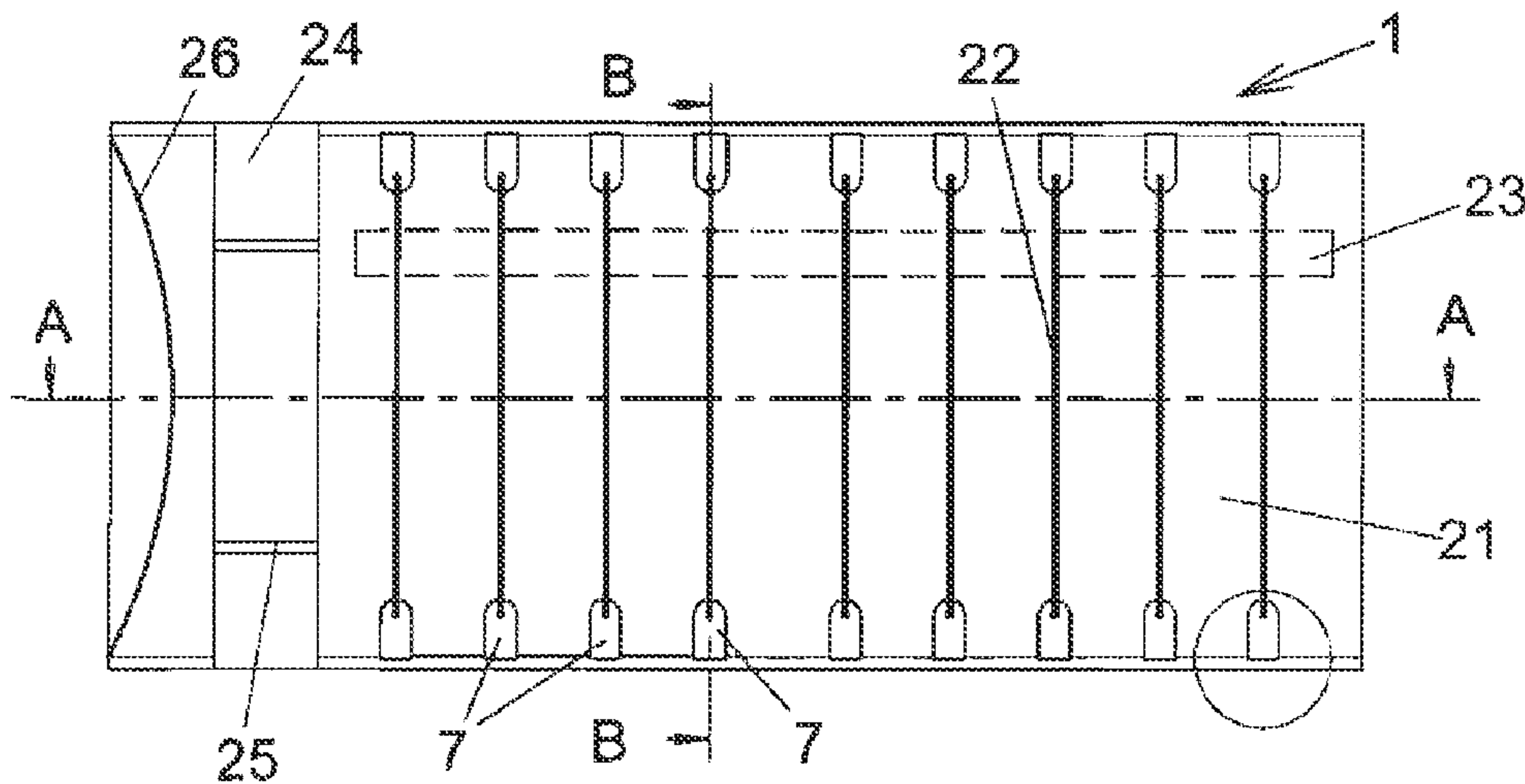

(86) **Date de dépôt PCT/PCT Filing Date:** 2010/01/18
 (87) **Date publication PCT/PCT Publication Date:** 2010/07/29
 (45) **Date de délivrance/Issue Date:** 2016/06/28
 (85) **Entrée phase nationale/National Entry:** 2011/07/07
 (86) **N° demande PCT/PCT Application No.:** SE 2010/050042
 (87) **N° publication PCT/PCT Publication No.:** 2010/085201
 (30) **Priorité/Priority:** 2009/01/22 (SE0900064-7)

(51) **Cl.Int./Int.Cl. B60P 1/28** (2006.01),
B62D 33/02 (2006.01), **B65D 88/12** (2006.01)
 (72) **Inventeur/Inventor:**
 LINDSTROM, BO, SE
 (73) **Propriétaire/Owner:**
 SSAB TECHNOLOGY AB, SE
 (74) **Agent:** MARKS & CLERK

(54) **Titre : CORPS DE PLATEFORME**
 (54) **Title: PLATFORM BODY**



(57) **Abrégé/Abstract:**

Platform body (1, 80) comprising a bottom (21) to which two opposite sides (31, 32, 41, 42, 63, 83, 84) are connected that either consist of long sides or of short sides as well as at least one additional side for the formation of a cargo volume (LV), said bottom having a bottom surface of a surface length between the opposite sides of the platform body (1, 80) that is larger than the spacing between said opposite sides, at least one part of said bottom being curved inward toward the cargo volume (LV), wherein at least one tie means (22) is mounted with one end thereof connected to one of the opposite sides of the platform body (1, 80) and with the other end thereof connected to the other opposite side of the platform body (1, 80) in order to eliminate deflection of said sides when the bottom of the platform (1, 80) is loaded by goods.

(12) INTERNATIONAL APPLICATION PUBLISHED UNDER THE PATENT COOPERATION TREATY (PCT)

(19) World Intellectual Property Organization
International Bureau(43) International Publication Date
29 July 2010 (29.07.2010)(10) International Publication Number
WO 2010/085201 A1

(51) International Patent Classification:

B60P 1/28 (2006.01) *B65D 88/12* (2006.01)
B62D 33/02 (2006.01)

(21) International Application Number:

PCT/SE2010/050042

(22) International Filing Date:

18 January 2010 (18.01.2010)

(25) Filing Language:

Swedish

(26) Publication Language:

English

(30) Priority Data:

0900064-7 22 January 2009 (22.01.2009) SE

(71) Applicant (for all designated States except US): **SSAB Oxelösund AB** [SE/SE]; S-613 80 Oxelösund (SE).

(72) Inventor; and

(75) Inventor/Applicant (for US only): **LINDSTRÖM, Bo** [SE/SE]; Lunda Prästgård, S-610 50 Jönåker (SE).(74) Agent: **Groth & Co. KB**; Box 6107, S-102 32 Stockholm (SE).

(81) Designated States (unless otherwise indicated, for every kind of national protection available): AE, AG, AL, AM, AO, AT, AU, AZ, BA, BB, BG, BH, BR, BW, BY, BZ, CA, CH, CL, CN, CO, CR, CU, CZ, DE, DK, DM, DO,

DZ, EC, EE, EG, ES, FI, GB, GD, GE, GH, GM, GT, HN, HR, HU, ID, IL, IN, IS, JP, KE, KG, KM, KN, KP, KR, KZ, LA, LC, LK, LR, LS, LT, LU, LY, MA, MD, ME, MG, MK, MN, MW, MX, MY, MZ, NA, NG, NI, NO, NZ, OM, PE, PG, PH, PL, PT, RO, RS, RU, SC, SD, SE, SG, SK, SL, SM, ST, SV, SY, TH, TJ, TM, TN, TR, TT, TZ, UA, UG, US, UZ, VC, VN, ZA, ZM, ZW.

(84) Designated States (unless otherwise indicated, for every kind of regional protection available): ARIPO (BW, GH, GM, KE, LS, MW, MZ, NA, SD, SL, SZ, TZ, UG, ZM, ZW), Eurasian (AM, AZ, BY, KG, KZ, MD, RU, TJ, TM), European (AT, BE, BG, CH, CY, CZ, DE, DK, EE, ES, FI, FR, GB, GR, HR, HU, IE, IS, IT, LT, LU, LV, MC, MK, MT, NL, NO, PL, PT, RO, SE, SI, SK, SM, TR), OAPI (BF, BJ, CF, CG, CI, CM, GA, GN, GQ, GW, ML, MR, NE, SN, TD, TG).

Declarations under Rule 4.17:

- as to applicant's entitlement to apply for and be granted a patent (Rule 4.17(ii))
- of inventorship (Rule 4.17(iv))

Published:

- with international search report (Art. 21(3))

(54) Title: PLATFORM BODY

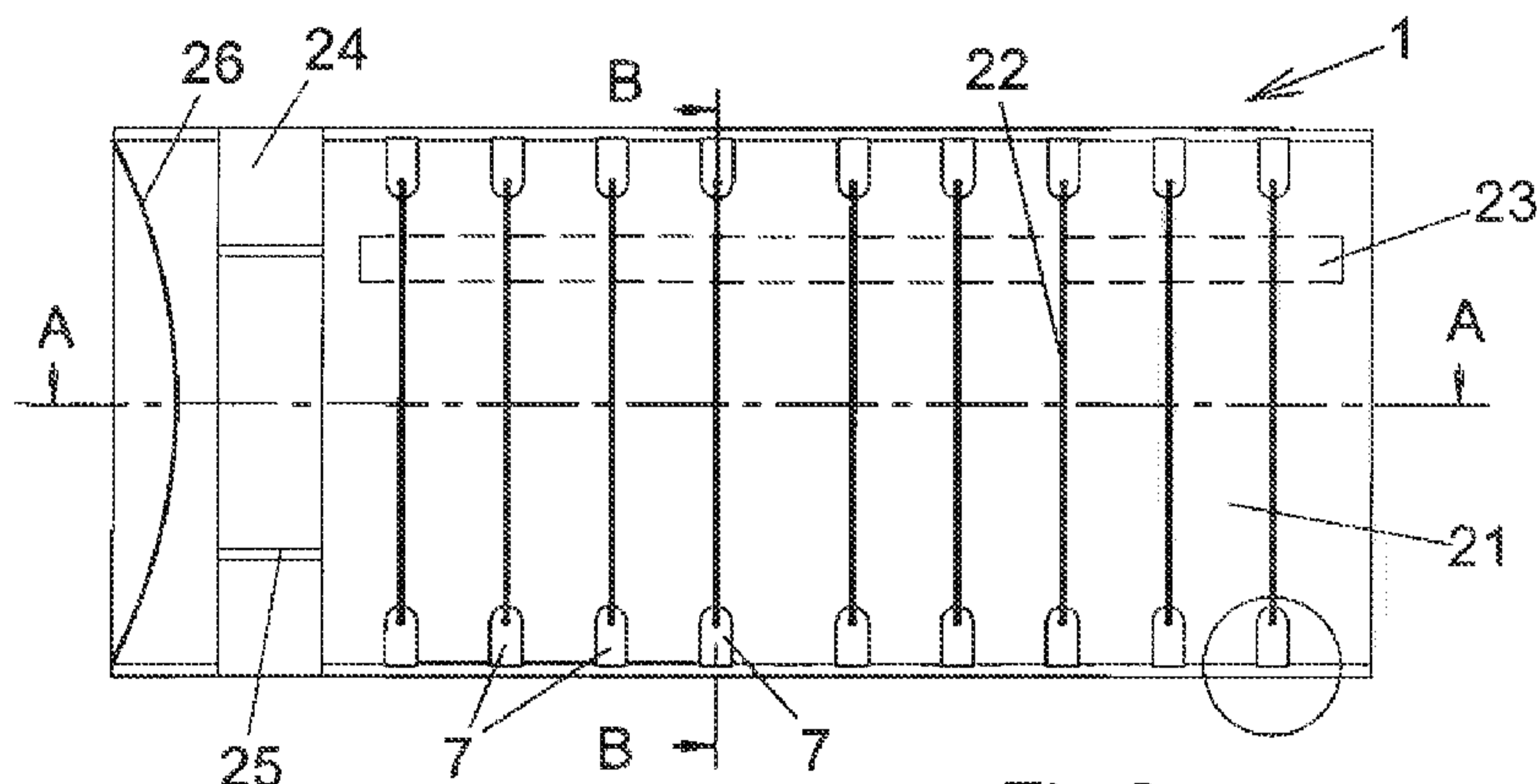

Fig 2

(57) **Abstract:** Platform body (1, 80) comprising a bottom (21) to which two opposite sides (31, 32, 41, 42, 63, 83, 84) are connected that either consist of long sides or of short sides as well as at least one additional side for the formation of a cargo volume (LV), said bottom having a bottom surface of a surface length between the opposite sides of the platform body (1, 80) that is larger than the spacing between said opposite sides, at least one part of said bottom being curved inward toward the cargo volume (LV), wherein at least one tie means (22) is mounted with one end thereof connected to one of the opposite sides of the platform body (1, 80) and with the other end thereof connected to the other opposite side of the platform body (1, 80) in order to eliminate deflection of said sides when the bottom of the platform (1, 80) is loaded by goods.

PLATFORM BODY

Technical Field

The present invention relates to the area of platform bodies of lorries or
5 trucks intended for heavier transportations such as scrap, stone or gravel. By
platform bodies in the present invention, reference is also made to load changer
containers, lorry platforms, dumper bodies and the like of the traditional
rectangular type of platforms.

10 *Background of the Invention*

Platform bodies for such transportations are formed with a bottom that is
subjected to great forces in the form of dynamic and static loads, above all upon
loading but also upon transportation and unloading. The dynamic load causes
deformation of the bottom of the platform body in the form of elastic deflection and
15 also plastic deformation because of this deflection. Such deflections represent
great stresses on weld joints between the bottom and the sides but also between
two adjacent sides that limit the cargo volume. In order to eliminate such
deflections and stresses, the material thickness has increased in both the walls
and the bottom, which has resulted in the weight of the platform having increased
20 considerably. In that connection, also the production cost for these platforms has
increased.

Summary of the Invention

The present invention aims at providing an improved platform body having
25 the same good function as previously known platform bodies but having a reduced
weight and thereby a greater loading capacity.

An additional object of the invention is to obtain portions of the bottom of
the cargo volume having an elastically resilient function in order to increase the
strength by absorbing the kinetic energy upon loading, above all in adjacent
30 welded splices.

Furthermore, an object of the invention is to minimize the deflection of
opposite sides of the cargo volume because of forces above all upon loading and
unloading of transported goods.

Moreover, an object is that opposite side walls should to a greater extent than previously carry the horizontal forces that arise from the platform when it is filled with cargo from above.

An object is also to provide a bottom of a platform body that is both rigid
5 and light.

According to an aspect of the present invention, there is provided a platform body comprising a bottom to which two opposite sides are connected that either consist of long sides or of short sides. Moreover, at least one additional side
10 is connected to said bottom for the formation of a cargo volume. Said bottom has a bottom surface of a surface length between the opposite sides of the platform body that is larger than the spacing between said opposite sides, at least one part of said bottom being curved inward toward the cargo volume. At least one tie means is mounted with one end thereof connected to one of the opposite sides of
15 the platform body and with the other end thereof connected to the other opposite side of the platform body in order to eliminate deflection of said sides when the bottom of the platform is loaded by goods. The ends of the tie means are connected to the sides of the platform body via a tie attachment connected to the respective side.

20 According to one embodiment of the invention, one end of the tie means is connected to an area near the connection of one side to the bottom of the platform, while the other end of the tie means is connected to an area near the connection of the other side to the bottom of the platform.

According to an additional embodiment of the invention, the tie means
25 is placed outside the cargo volume.

The placement of the tie means is in the vicinity of the bottom of the platform body, i.e., where the stresses of said bottom on the walls are the greatest.

According to one embodiment of the invention, the ends of the tie means are connected to the sides of the platform body via a mounting part that is
30 connected to the respective side and extends inward toward the centre of the platform body in the direction of the opposite side. By "side", reference is made to either a long side or a short side, i.e., an end wall.

According to one embodiment of the invention, the tie means is formed either as a tie-rod or as a wire. Conventional hot-galvanized tie-rods having a load-carrying capacity of 83–approx. 20 kN may, for instance, be used in connection with the present invention. The tie-rod may also be formed with a
5 central centre part that is provided with two end parts that in turn are connected to the mounting part via a screw joint.

In other embodiments, the tie means may be formed as a plate. In such an embodiment, this plate may form at least one, possibly closed, channel between said bottom and said plate. Such a channel may be arranged for
10 conveying warm exhaust fumes in order to avoid freezing of the transported goods.

By the fact that said bottom of the platform body is arched inward toward the cargo volume, i.e., upward, a space is obtained under the bottom that also may be used for miscellaneous cabling and hydraulic hoses.

15 According to one embodiment of the invention, the platform body is provided with longitudinal supporting beams through which the tie means extends without any transfer of force between the beam and the tie means.

Additional embodiments of the invention are that said bottom is formed as two bottom parts that are interconnected by, e.g., a screw joint along
20 the centre of the platform body, each bottom part being curved inward toward the cargo volume. By "the centre of the platform body", it is, in this connection, meant the middle in the transverse direction or the middle in the longitudinal direction.

According to an additional embodiment of the invention, at least one of said sides is connected to said bottom via hinges so that the side, either a long
25 side or a short side, can be lowered.

Naturally, the long sides and the short sides may be equally long, but the terminology has been used considering the fact that the sides usually are longer in the longitudinal direction than the sides in the transverse direction.

Plate thicknesses of the bottom and the sides are in the range of 3–10
30 mm, preferably 4–5 mm, of material grades that correspond to wearing plate. Possibly, the material grade marketed under the trademark HARDOX[®] may be used. Also other steel grades may of course be used for the manufacture of a platform body according to the invention. HARDOX[®] is a registered trademark that is owned by SSAB Oxelösund AB.

For instance, a platform body, having a side thickness of 4 mm and bottom thickness of 5 mm that is 6 m long, 1 m high and 2,5 m wide, has a weight of 1600 kg. This should be compared with a conventional platform body of the corresponding size that weighs 3500 kg.

5 The bottom plate according to the invention is curved into the intended curvature by roller bending or press braking. The connection parts of the bottom plate are press braked. The joining between the bottom parts or between the bottom part and the side part is made by a screw joint or a welded joint.

10 When longitudinal supporting beams are used upon great loads, rubber pads are suitably put between the beams and the bottom parts to decrease the stress on the beams. In other cases, just an air gap is used between the bottom part and the beam.

 Furthermore, supporting bulkheads may constitute a part of the space between the bottom and the tie means in the form of a plate.

15 The bottom of the platform body may also be provided with a small angled rear part, a so-called chute, to facilitate loading as well as get a more uniform distribution of bulk goods upon tipping. A suitable angle between the bottom part and the chute is 15°.

 According to another aspect of the present invention, there is provided a
20 platform body comprising a bottom to which two opposite sides are connected that either consist of long sides or of short sides as well as at least one additional side for the formation of a cargo volume, said bottom having a bottom surface of a surface length between the opposite sides of the platform body that is larger than the spacing between said opposite sides, at least one part of said bottom being
25 curved inward toward the cargo volume, wherein at least one tie means is mounted with one end thereof connected to one of the opposite sides of the platform body and with the other end thereof connected to the other opposite side of the platform body in order to eliminate deflection of said sides when the bottom of the platform is loaded by goods whereby said tie means is arranged to act
30 against outwardly directed forces acting on said sides, which forces are generated when the bottom of the platform body is loaded by goods.

Brief Description of the Drawings

The invention will now be described in more detail by means of embodiment examples, reference being made to the accompanying drawings, wherein

- 5 Figure 1 shows a side view of a platform body according to a first embodiment of the invention,
- Figure 2 shows the platform body according to Figure 1 from the underside,
- Figure 2a shows an enlargement of the encircled area in Figure 2,
- 10 Figure 3 shows a section B–B through the platform body according to Figure 2,
- Figure 3a shows an enlargement of the encircled area in Figure 3,
- Figure 4 shows an end view of the platform body from behind according to Figure 1,
- 15 Figure 5 shows a section A–A through the platform body according to Figure 2,

- Figure 5a shows an enlargement of the encircled area in Figure 5,
Figure 6 shows an explanatory sketch of a second embodiment of the present invention,
Figure 7 shows an explanatory sketch of a third embodiment of the present invention,
5 Figure 8 shows an explanatory sketch of a fourth embodiment of the present invention.

Description of the Invention

10 Figure 1 shows a platform body 1 having a rear end 2 out of which the goods can be tipped by the platform body being turned by hydraulics around a bearing axis 3. The front end 4 of the platform body is provided with an end wall that is facing a driver's cab, not shown, of the vehicle. The platform body is provided with edge beams 5 as well as an end wall beam 6. In an area near the
15 connection of one of the long sides to the bottom of the platform, the lower edge of the platform body is provided with a number of welded-on tie attachments 7 that extend from the long side downward and in under the bottom of the platform body.

Figure 2 shows said tie attachments 7 from the underside of the platform body 1, the attachments 7 being directed inward toward the centre of the platform
20 body in the direction of counter-directed tie attachments on the opposite side of the platform body. In the figure, nine tie attachments are shown on each side of the bottom 21 of the platform body, but naturally the number and placement may be varied within the scope of the invention. To each tie attachment 7, an end of a tie means 22 is connected so that the tie means has an orientation essentially
25 perpendicular to the longitudinal direction of the platform body 1. Furthermore, one or more longitudinal supporting beams 23 may be placed under the bottom of the platform, which has been schematically shown by a beam drawn with dashed lines. The figure also shows a cross beam 24 placed on which bearing seats 25 for the bearing axis are situated. In addition, it is seen that the rear termination of said
30 bottom is made with an arc-shaped reinforcing bending 26.

Figure 2a shows a first design of the attachment of the end of the tie means 22 in a tie attachment 7, the tie attachment being provided with a hole 27 through which the end of the tie means is inserted and fixed by, e.g., a screw joint on the upperside of the tie attachment 7.

Figure 3 shows a central section through the platform body with the inside of a long side 31 connected to the bottom 21 of the platform by a welded joint. A front end wall 32 is correspondingly connected to both the long side and said bottom. The end wall beam 6 and the edge beam 5 are shown in the figure. In addition, the tie attachments 7 are shown with the tie means 22.

Figure 3a shows an alternative design of the connection of the tie means 22 to the tie attachment. In this embodiment, the outer part of the tie attachment is provided with connection lugs 33, 34 situated on both sides of the attachment and provided with through holes for a screw-nut joint 35 that at the tie attachment locks a coupling washer 36 connected to the tie means 22.

Figure 4 shows an end view from the rear end of the platform body 1, the bearing seats 25 on the cross beam 24 as well as the curvature of the bottom 21 of the platform body inward toward the cargo volume "LV". By "the cargo volume", reference is made to the volume that is limited by the bottom 21, the sides 41, 42 and the upper edge 43 of the sides. By this curvature, said bottom 21 has a bottom surface of a surface length between the opposite sides 41, 42 of the platform body that is larger than the spacing between said opposite sides. Thus, a downwardly directed force "F" that acts on said bottom 21 can generate outwardly directed forces "F₁" and "F₂" on the lower portions of the opposite sides 41, 42.

Figure 5 shows a section taken through the platform body 1 through a tie device 22. The tie device 22 is placed under the bottom 21 of the platform body and connected to the lower parts of the opposite sides 41, 42 to act against a deflection of the sides because of the forces "F₁" and "F₂". The tie device 22 is connected to a tie attachment 7 via a coupling device that is shown encircled in the figure.

Figure 5a shows an enlargement of the coupling device that comprises said connection lugs 33, 34 attached in the end of the tie attachment 7. The tie means 22 is connected to the coupling washer 36 that in turn is connected to the tie attachment via the screw 51 and nut 52 of the screw-nut joint 35. The connection between the tie means 22 and the coupling washer 36 consists of a muff coupling 53 that is welded-on onto the coupling washer and connects to the tie device 22 via a jamb nut 54. The figure also shows the bottom 21 of the platform curved inward toward the cargo volume.

Figures 6 and Figure 7 show alternative designs of tie means 221, 222 that either can be screwed by a screw joint 61 directly through lower parts to the sides as in Figure 6, or be integrated and welded to the sides via tie attachments 71. The tie means 221, 222 can either be made as rods, as wires or as plates. In case the tie means is formed as a plate, a channel 62, 72 between the bottom 21 and said plate is formed. The channel may be used to contain hydraulic pipes, cabling, etc. An alternative use of the channel is to introduce exhaust fumes into the same to heat up the bottom with the purpose of eliminating freezing fast of goods residues after tipping. Figure 6 also shows that a long side 63 may be formed foldable to allow unloading of the goods laterally.

Figure 8 shows an embodiment of the invention for an extra wide platform body 80, the bottom 21 of which is formed with a first bottom part 81 and a second bottom part 82, which bottom parts are equally large as well as interconnected at the centre of the platform body. Each bottom part 210, 211 is curved inward toward the cargo volume LV. Within the scope of the invention, it is also possible to form one of said bottom parts curved while the other is plane. In addition, it is possible to form the bottom of the platform body with a plurality of co-operating bottom parts, at least one bottom part of which is curved inward toward the cargo volume. Between the side parts 83, 84 of the platform body, one or more tie means 22 are mounted to carry outwardly directed loads on the side parts when the bottom parts are loaded. The design of said tie means may be formed like the tie means that have been previously described.

The embodiment according to Figure 8 may also be formed with a channel according to Figures 6 and 7 and/or be formed with stiffening beams in the longitudinal direction and/or in the transverse direction.

Within the scope of the invention, implementations of an embodiment described above may also be used in another embodiment, for instance, the fixing of the tie means that has been shown in Figures 1-3a may alternatively be used in the embodiment according to Figure 8 instead of the shown screw joint 85.

The embodiments of the invention in which an exclusive property or privilege is claimed are defined as follows:

1. A platform body comprising a bottom to which two opposite sides are connected that either consist of long sides or of short sides as well as at least one additional side for the formation of a cargo volume, said bottom having a bottom surface of a surface length between the opposite sides of the platform body that is larger than the spacing between said opposite sides, at least one part of said bottom being curved inward toward the cargo volume, wherein at least one tie means is mounted with one end thereof connected to one of the opposite sides of the platform body and with the other end thereof connected to the other opposite side of the platform body in order to eliminate deflection of said sides when the bottom of the platform is loaded by goods whereby said tie means is arranged to act against outwardly directed forces acting on said sides, which forces are generated when the bottom of the platform body is loaded by goods.
2. The platform body according to claim 1, wherein the ends of the tie means are connected to the sides of the platform body via a tie attachment connected to the respective side.
3. The platform body according to claim 1 or 2, wherein one end of the tie means is connected to an area near the connection of one side to the bottom of the platform, and that the other end of the tie means is connected to an area near the connection of the other side to the bottom of the platform.
4. The platform body according to any one of claims 1 to 3, wherein the tie means is placed outside the cargo volume.
5. The platform body according to any one of claims 2 to 4, wherein the tie attachment extends inward toward the centre of the platform body in the direction of the opposite side.

6. The platform body according to any one of claims 1 to 5, wherein the tie means is formed either as a tie-rod or as a wire.
7. The platform body according to claim 6, wherein the platform body is provided with longitudinal supporting beams through which the tie means extends without any transfer of force between the supporting beam and the tie means.
8. The platform body according to any one of claims 1 to 5, wherein the tie means is formed as a plate that forms at least one channel between said bottom and said plate.
9. The platform body according to claim 8, wherein the channel is closed and arranged for conveying warm exhaust fumes in order to avoid freezing of the transported goods.
10. The platform body according to any one of claims 1 to 9, wherein said bottom is formed as two bottom parts that are interconnected along the centre of the platform body, each bottom part being curved inward toward the cargo volume.
11. The platform body according to any one of claims 1 to 10, wherein at least one of said sides is connected to said bottom via hinges so that the side can be lowered.

1/2

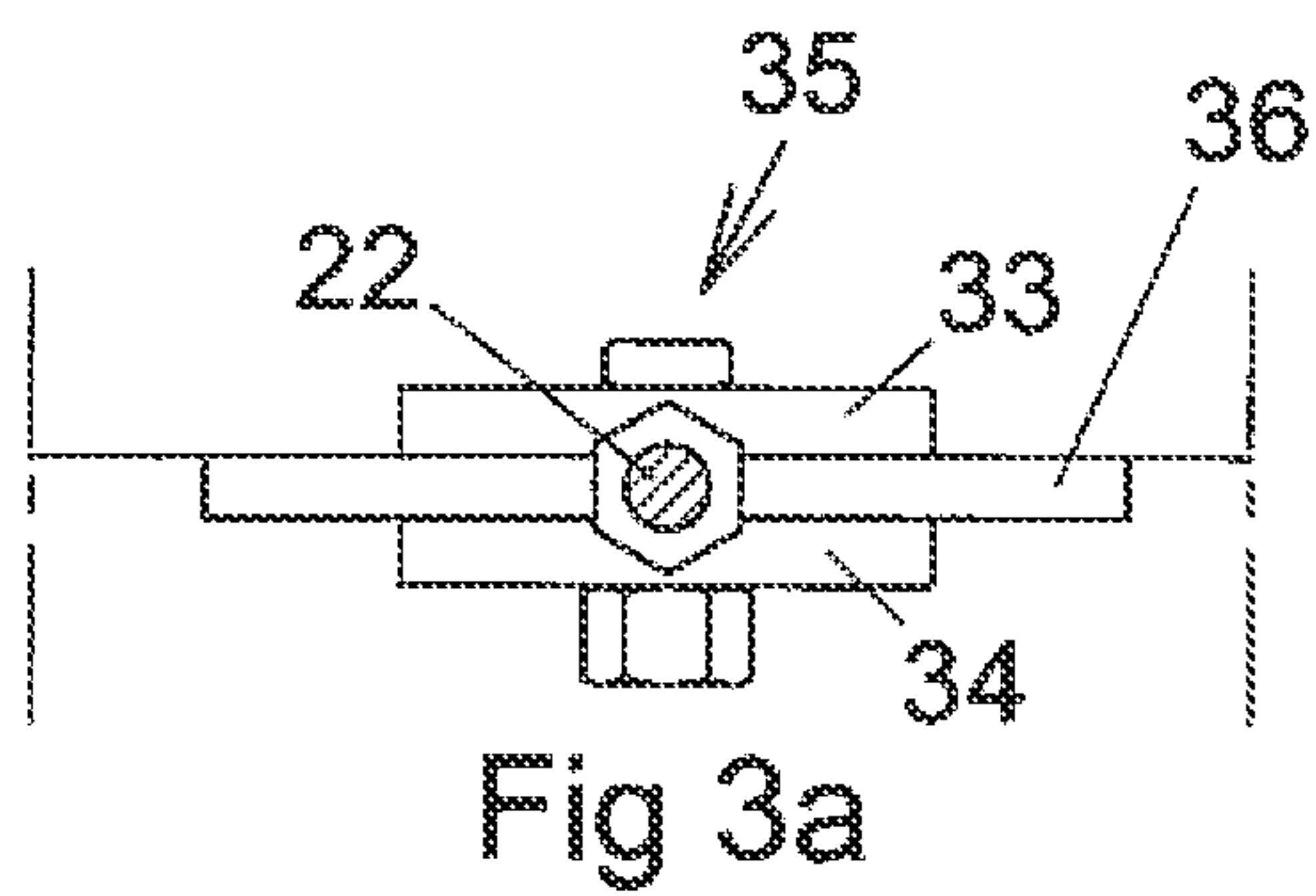
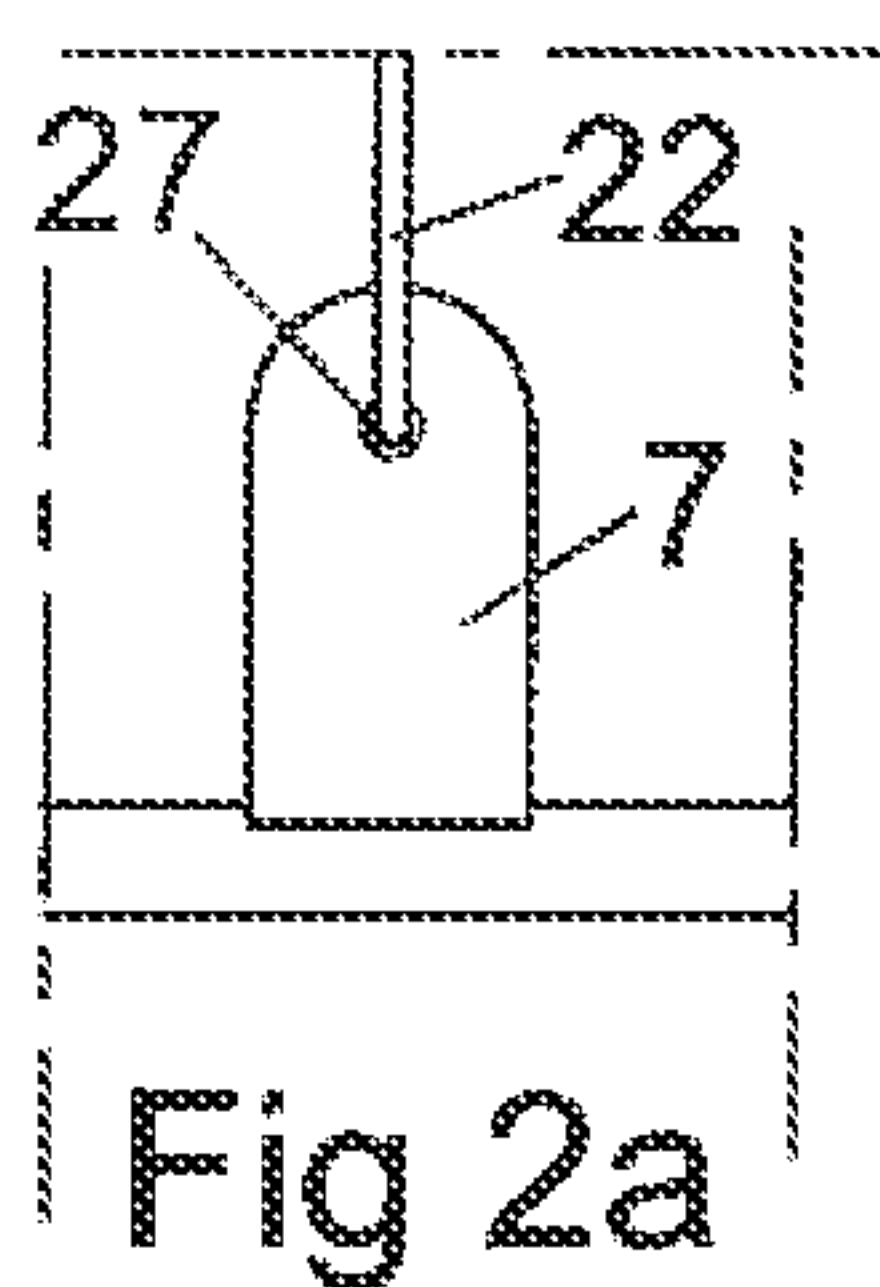
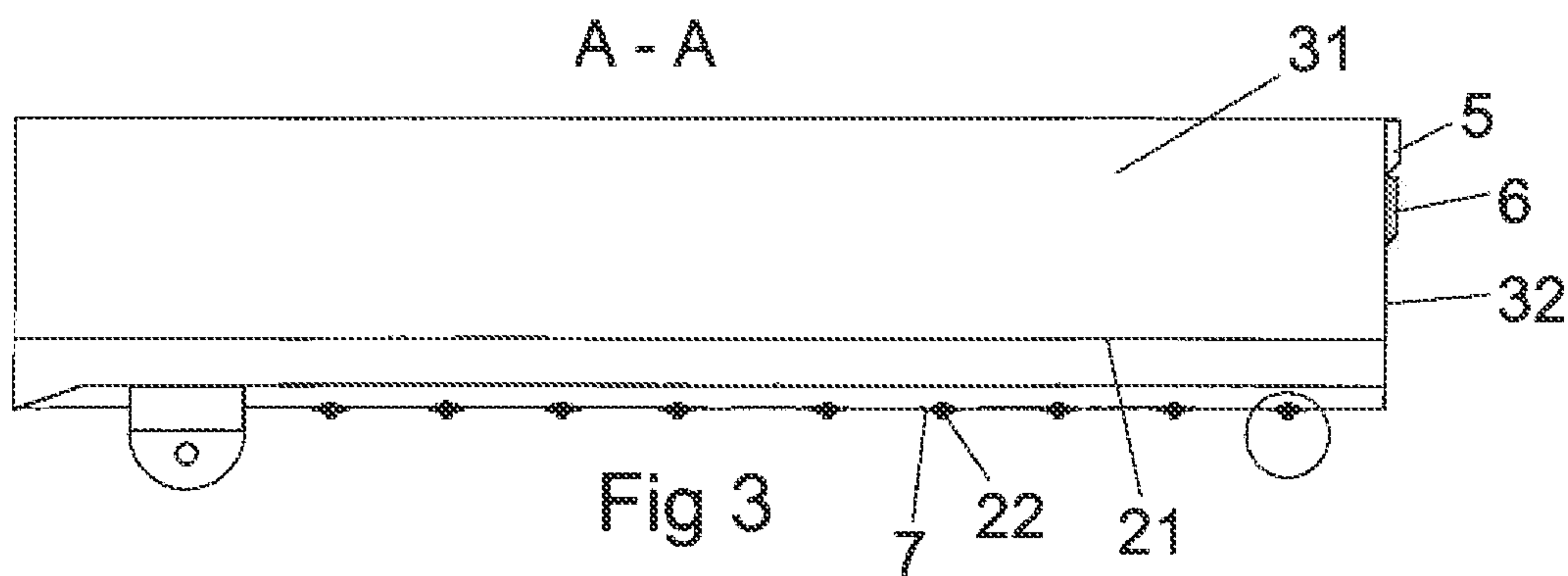
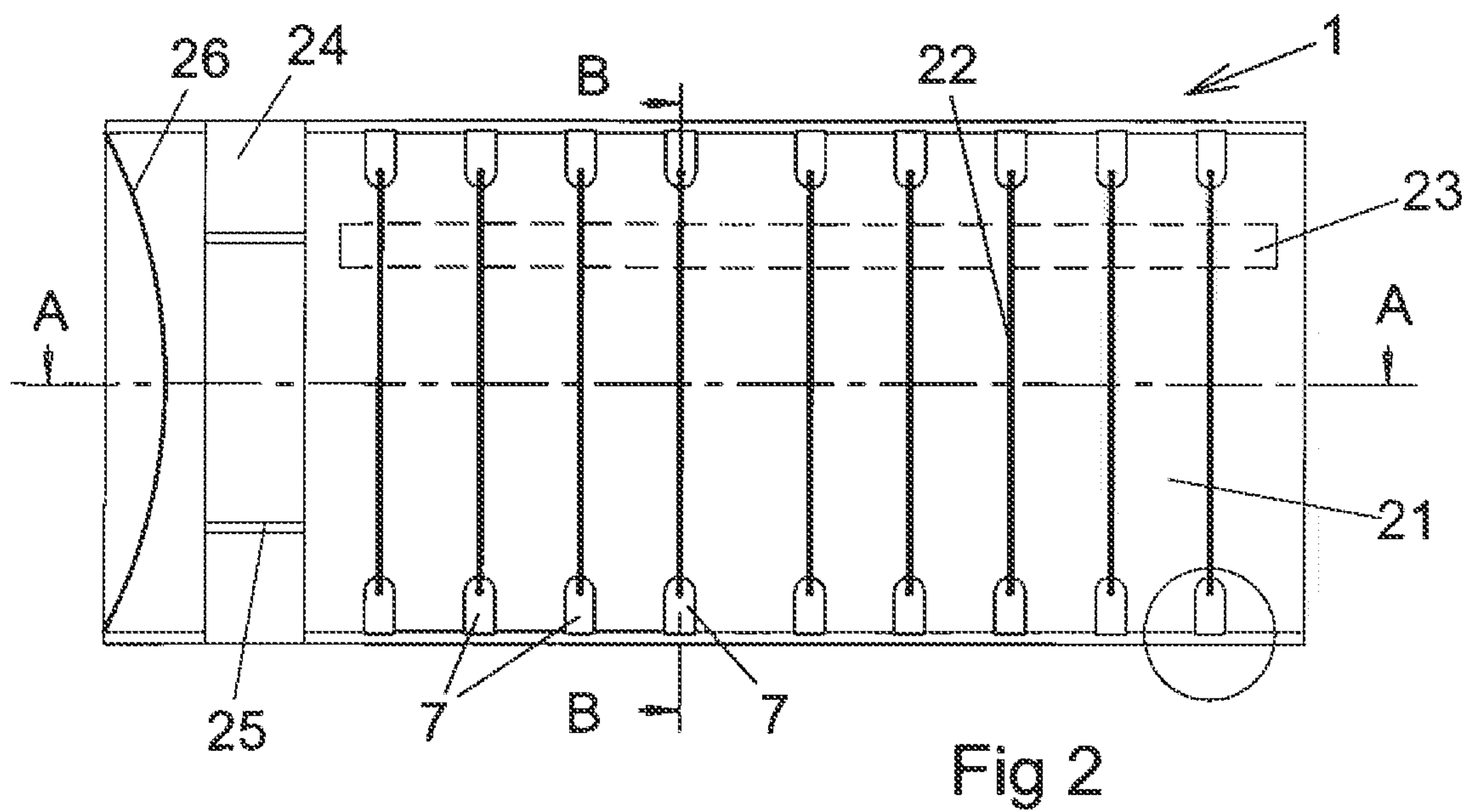
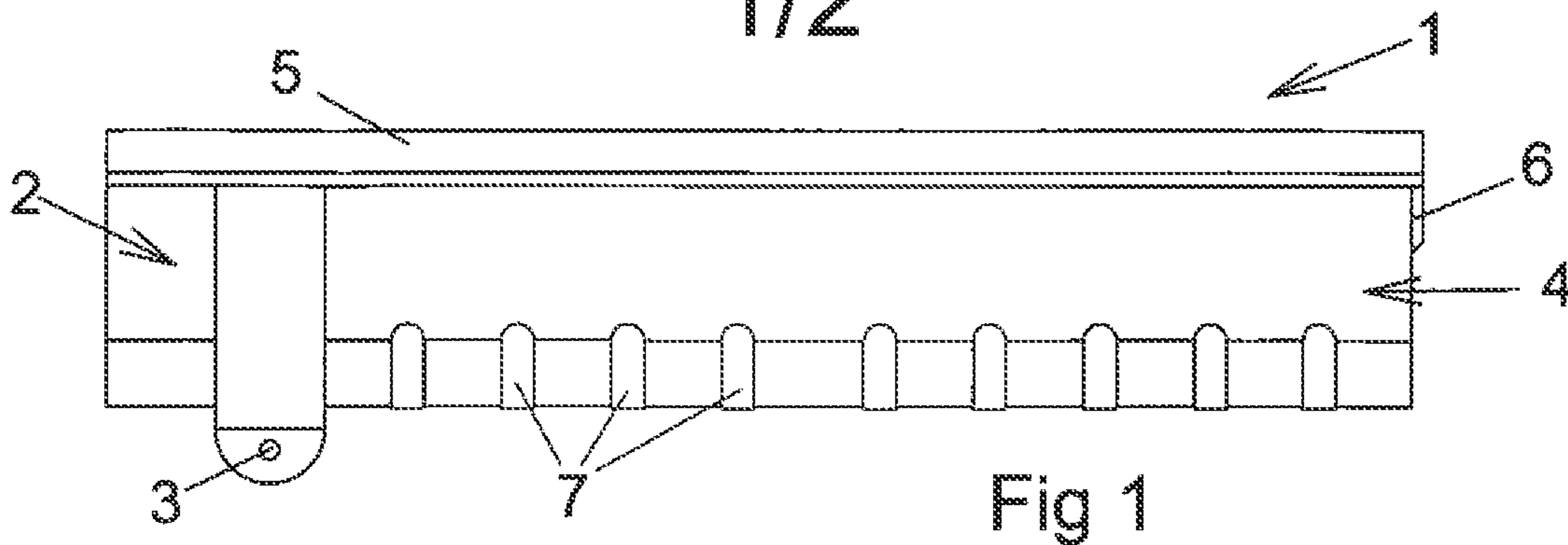

2/2

