

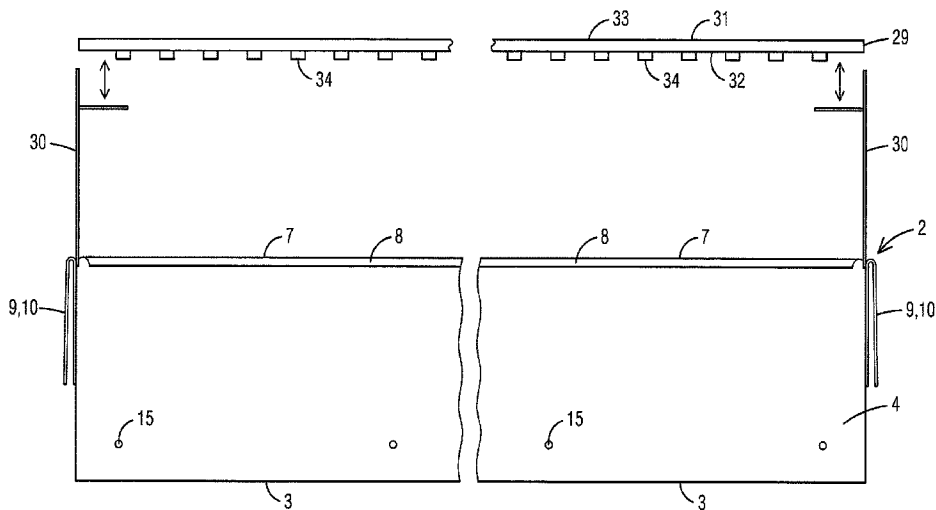

(86) Date de dépôt PCT/PCT Filing Date: 2019/10/01
 (87) Date publication PCT/PCT Publication Date: 2020/05/07
 (45) Date de délivrance/Issue Date: 2023/03/28
 (85) Entrée phase nationale/National Entry: 2020/09/24
 (86) N° demande PCT/PCT Application No.: US 2019/053929
 (87) N° publication PCT/PCT Publication No.: 2020/091935
 (30) Priorités/Priorities: 2018/10/29 (US16/173,841);
 2019/05/15 (US16/412,969)

(51) Cl.Int./Int.Cl. *A01G 9/16* (2006.01),
A01G 9/14 (2006.01), *A01G 9/24* (2006.01)
 (72) Inventeur/Inventor:
 AVERY, DONALD J., US
 (73) Propriétaire/Owner:
 AVERY, DONALD J., US
 (74) Agent: DEETH WILLIAMS WALL LLP

(54) Titre : APPAREIL AGRICOLE
 (54) Title: AGRICULTURAL APPARATUS



(57) Abrégé/Abstract:

An agricultural apparatus (1) that provides a system of vessels (2) arranged vertically for growing plants that allows crops to be grown in confined areas and in geographic areas where crops cannot normally be grown on various planet surfaces.

(12) INTERNATIONAL APPLICATION PUBLISHED UNDER THE PATENT COOPERATION TREATY (PCT)

(19) World Intellectual Property
Organization
International Bureau

(43) International Publication Date
07 May 2020 (07.05.2020)



(10) International Publication Number
WO 2020/091935 A1

(51) International Patent Classification:

A01G 9/16 (2006.01) *A01G 9/14* (2006.01)
A01G 9/24 (2006.01)

(21) International Application Number:

PCT/US2019/053929

(22) International Filing Date:

01 October 2019 (01.10.2019)

(25) Filing Language:

English

(26) Publication Language:

English

(30) Priority Data:

16/173,841 29 October 2018 (29.10.2018) US
16/412,969 15 May 2019 (15.05.2019) US

(72) Inventor; and

(71) Applicant: **AVERY, Donald J.** [US/US]; c/o Livingston
loeffler, P.A., 963 Trail Terrace Drive, Naples, Florida
34103 (US).

(74) Agent: **LIVINGSTON, Edward M.** et al.; Livingston Lo-
effler, P.A., 963 Trail Terrace Drive, Naples, Florida 34103
(US).

(81) Designated States (unless otherwise indicated, for every
kind of national protection available): AE, AG, AL, AM,

AO, AT, AU, AZ, BA, BB, BG, BH, BN, BR, BW, BY, BZ,
CA, CH, CL, CN, CO, CR, CU, CZ, DE, DJ, DK, DM, DO,
DZ, EC, EE, EG, ES, FI, GB, GD, GE, GH, GM, GT, HN,
HR, HU, ID, IL, IN, IR, IS, JO, JP, KE, KG, KH, KN, KP,
KR, KW, KZ, LA, LC, LK, LR, LS, LU, LY, MA, MD, ME,
MG, MK, MN, MW, MX, MY, MZ, NA, NG, NI, NO, NZ,
OM, PA, PE, PG, PH, PL, PT, QA, RO, RS, RU, RW, SA,
SC, SD, SE, SG, SK, SL, SM, ST, SV, SY, TH, TJ, TM, TN,
TR, TT, TZ, UA, UG, US, UZ, VC, VN, ZA, ZM, ZW.

(84) Designated States (unless otherwise indicated, for every
kind of regional protection available): ARIPO (BW, GH,
GM, KE, LR, LS, MW, MZ, NA, RW, SD, SL, ST, SZ, TZ,
UG, ZM, ZW), Eurasian (AM, AZ, BY, KG, KZ, RU, TJ,
TM), European (AL, AT, BE, BG, CH, CY, CZ, DE, DK,
EE, ES, FI, FR, GB, GR, HR, HU, IE, IS, IT, LT, LU, LV,
MC, MK, MT, NL, NO, PL, PT, RO, RS, SE, SI, SK, SM,
TR), OAPI (BF, BJ, CF, CG, CI, CM, GA, GN, GQ, GW,
KM, ML, MR, NE, SN, TD, TG).

Published:

— with international search report (Art. 21(3))

(54) Title: AGRICULTURAL APPARATUS

FIG. 9

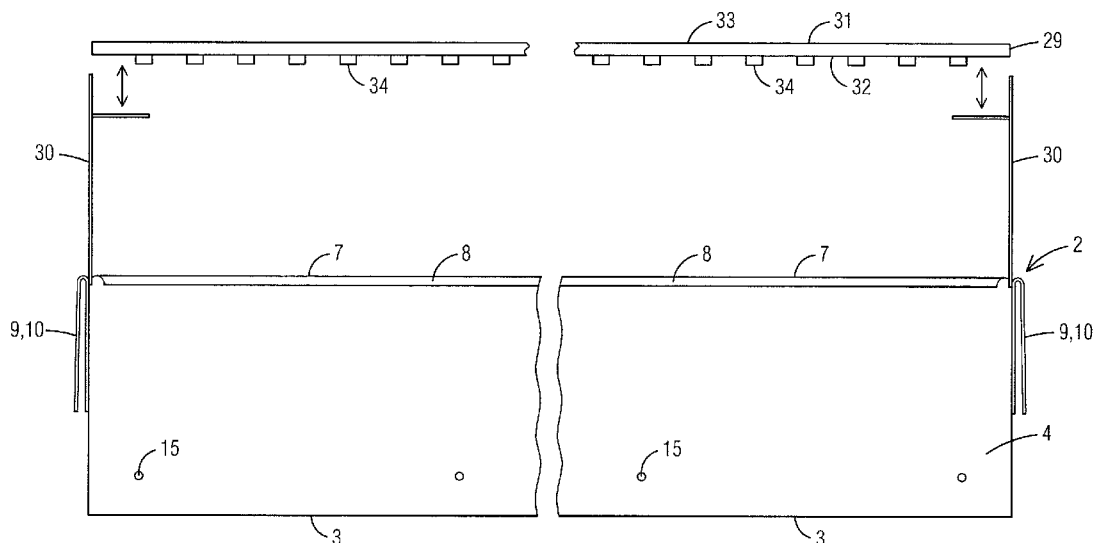

(57) Abstract: An agricultural apparatus (1) that provides a system of vessels (2) arranged vertically for growing plants that allows crops to be grown in confined areas and in geographic areas where crops cannot normally be grown on various planet surfaces.



WO 2020/091935 A1

AGRICULTURAL APPARATUS

FIELD OF THE INVENTION

This invention relates to agricultural devices for growing plants and more particularly a free standing system of vertically arranged vessels used to grow plants on all plant surfaces.

5

BACKGROUND OF THE INVENTION

Farmland is becoming scarce due to over-development, contamination and environmental issues. Meanwhile, the demand for food is becoming greater every year due to an increasing population.

This has resulted in higher food prices and food shortages, especially in areas where land is at a premium and/or available land is not usable for crop production.

10

Therefore, a need exists for an agricultural apparatus that provides a system of vessels arranged vertically for growing plants that allows crops to be grown in confined areas and in geographic areas where crops cannot normally be grown on various planet surfaces.

SUMMARY OF THE INVENTION

15

The primary object of the present invention is to provide an agricultural apparatus that provides a system of vessels arranged vertically for growing plants on all planet surfaces that allows crops to be grown in confined areas and in geographic areas where crops cannot normally be grown on various planet surfaces.

An additional object of the present invention is to provide an agricultural apparatus that improves photosynthesis and reduces damage caused by intense direct midday sunlight.

20

An additional object of the present invention is to provide an agricultural apparatus having a floating base, thereby allowing the apparatus to be constructed and used on open water, ponds, lakes, swamps, marshes and so forth.

An additional object of the present invention is to provide an agricultural apparatus that reduces and/or eliminates soil erosion, runoff of pesticides, runoff of fertilizers and runoff of other soil and water contaminants.

25

An additional object of the present invention is to provide an agricultural apparatus that provides a physical barrier to birds, animals, insects and other creatures.

The present invention fulfills the above and other objects by providing an agricultural apparatus that provides a system of vertical shelves and/or vessels used for growing plants on all planet surfaces, in confined areas and in geographic areas where crops cannot normally be grown

30

in sandy, arid, salty soil, rocky and lava surfaces, water, swamps, marshes and so forth. The agricultural apparatus of the present invention is a free standing arrangement support structure made up of vertical supports and horizontal supports that may be arranged in a variety of configurations depending on the available space. The support structure may be secured to the
5 ground or have a base that holds the support structure in an upright position. The base may be a floating base to allow the agricultural apparatus to be used on water, in swamps, in marshes or in other liquid entities.

The agricultural apparatus may have a reflective roof cover to shade the plants and prevent extreme sunlight from the midday sun from slowing down photosynthesis occurring in the plants
10 as photosynthesis is the most underutilized important health and environmental element effecting humanity on the planet.

This deficiency can be corrected by an above all planet surfaces plant growth system.

In addition, the agricultural apparatus may have an exterior cover, such as a mesh or screen, to protect the plants from animals and/or insects.

15 The above and other objects, features and advantages of the present invention should become even more readily apparent to those skilled in the art upon a reading of the following detailed description in conjunction with the drawings wherein there is shown and described illustrative embodiments of the invention.

BRIEF DESCRIPTION OF THE DRAWINGS

20 In the following detailed description, reference will be made to the attached drawings in which:

FIG. 1 is a front view of a vessel from an agricultural apparatus of the present invention;

FIG. 2 is an end view of a vessel from an agricultural apparatus of the present invention;

FIG. 3 is a perspective top view of an agricultural apparatus having a plurality of vessels
25 supported by a support structure having vertical supports and horizontal supports;

FIG. 4 is a side perspective view of a support structure of the present invention wherein vessels are supported by multiple vertical supports;

FIG. 5 is a side perspective view of a support structure of the present invention wherein vessels are directly supported by a vertical support;

30 **FIG. 6** is a side view of an agricultural apparatus of the present invention in use and anchored using stakes;

FIG. 7 is a side view of an agricultural apparatus of the present invention in use and supported by a floating base;

FIG. 8 is a side view of an agricultural apparatus having a plurality of vessels arranged around a vertical support in a circular configuration;

5 **FIG. 9** is a front view of a vessel from an agricultural apparatus of the present invention having an individual vessel cover;

FIG. 10 is a sectional side view along lines A-A of **FIG. 2** of a vessel from an agricultural apparatus of the present invention;

10 **FIG. 11** is a side perspective view of a support structure of the present invention wherein vessels are supported by multiple vertical supports that are capable of being rolled for easy transportation of the support structure; and

FIG. 12 is a partial side view of an agricultural apparatus having a plurality of vessels arranged around a threaded vertical support in a circular configuration.

DESCRIPTION OF THE PREFERRED EMBODIMENTS

15 For purposes of describing the preferred embodiment, the terminology used in reference to the numbered accessories in the drawings is as follows:

1. agricultural apparatus, generally
2. vessel
3. bottom panel of vessel
- 20 4. front panel of vessel
5. rear panel of vessel
6. side panel of vessel
7. upper perimeter edge of vessel
8. lip
- 25 9. attachment means
10. clip
11. support structure
12. vertical support
13. horizontal support
- 30 14. liquid absorbent layer
15. vent hole

16. parallel row
 17. base
 18. anchoring bracket
 19. support bracket
 5 20. first half of support bracket
 21. vertical tube of support bracket
 22. second half of support bracket
 23. horizontal tube of support bracket
 24. roof cover
 10 25. stake
 26. floating base
 27. exterior cover
 28. exterior support frame
 29. individual vessel cover
 15 30. cover support
 31. upper surface
 32. lower surface
 33. reflective surface
 34. light
 20 35. protective barrier
 36. irrigation drip line
 37. distal end
 38. proximal end
 39. water source
 25 40. rolling means
 41. suspension means

With reference to **FIGS. 1** and **2**, a front view and end view, respectively, of a vessel **2** from an agricultural apparatus **1** of the present invention is illustrated. The vessel **2** is used to hold a substrate, such as dirt, and one or more plants. The vessel **2** is substantially rectangular-shaped and comprises a bottom panel **3**, front panel **4**, rear panel **5** and side panels **6**. An upper perimeter edge **7** of the vessel may be folded or curled to provide a lip **8**. One or more attachment means **9**,

such as clips **10**, are located on the vessel **2** and are used to attach the vessel **2** to a support structure **11**, as illustrated in **FIG. 3**. As illustrated herein, the clips **10** are located on the side panels **6** and extend from the upper perimeter edge **7** of the side panels **6** in an L-shaped fashion, thereby allowing the clips **10** to be placed over a horizontal support **13**, as illustrated in **FIG. 3**. However, attachment means **9**, such as clips **10**, may be located on front panel **4**, rear panel **5** and/or side panels **6**.

A liquid absorbent layer **14** is located on an inner surface of the bottom panel **3** of the vessel **2** to retain moisture for the plants contained within the vessel **2**, as illustrated in **FIG. 10**. One or more vent holes **15** may be located on the front panel **4**, rear panel **5** and/or side panels **6**.

With reference to **FIG. 3**, a perspective top view of an agricultural apparatus **1** having a plurality of vessels **2** supported by a support structure **11** having elongated vertical supports **12** and elongated horizontal supports **13** is illustrated. The support structure **11** comprises a plurality of vertical supports **12** supporting a plurality of horizontal supports **13**. The vertical supports **12** and the horizontal supports **13** may be adjustable lengthwise to allow the support structure **11** to be made larger or smaller. The horizontal supports **13** are spaced apart at various heights on the vertical supports **12** to create a shelf system. As illustrated herein, the vertical supports **12** are arranged in two parallel rows **16** wherein the horizontal supports **13** span the distances between the vertical supports **12** contained in each parallel row **16**. A plurality of vessels **2** are located between the parallel rows **16** wherein attachment means **9**, such as clips **10**, engage the horizontal supports **13**. The vessels **2** may then be spaced apart horizontally and vertically within the support structure **11** to create a stacked configuration of vessels **2**, thereby allowing numerous plants to be grown within the foot print of the support structure **11**.

With reference to **FIG. 4**, a side perspective view of a support structure **11** of the present invention wherein vessels **2** are directly supported by multiple vertical supports **12** is illustrated. As illustrated herein, the support structure **11** comprises at least one vertical support **12**, which may be tubular-shaped for strength. The support structure **11** may be secured to the ground via a base **17**, such as anchoring brackets **18**, stakes, spikes, foundational supports, weights, feet, and so forth, which stabilize the support structure **11** in an upright position. The support structure **11** may be placed on a variety of surfaces, such as hard surfaces, dirt, swamp, marsh, water and so forth. As illustrated in **FIG. 4**, the support structure **11** comprises a plurality of anchoring brackets **18** that are L-shaped.

Vessels **2** span the lengths between two vertical supports **12** creating an H-shaped configuration. The vessels **2** are secured to the vertical supports **12** via an attachment means **9**, such as support brackets **19**. The support brackets **19** illustrated herein comprise two halves wherein a first half **20** is a vertical tube **21** and the second half **22** is a horizontal tube **23** integral to each other. The vertical tube **21** is placed over the vertical support **11** and the horizontal tube **23** is placed over the vessel **2**. A plurality of vessels **2** may be spaced apart height wise on the at least one vertical support **12** to create stacked levels of vessels **2**.

With reference to **FIG. 5**, a side perspective view of a support structure **11** of the present invention wherein vessels **2** are directly supported by a vertical support **12** is illustrated. The vessels **2** may be supported by a single vertical support **12**, thereby creating a T-shaped configuration. Each vessel **2** is secured to the vertical support **12** via an attachment means **9**, such as support brackets **19**.

With reference to **FIG. 6**, a side view of an agricultural apparatus **1** of the present invention in use is illustrated. Vessels **2** span the lengths between two vertical supports **12** creating an H-shaped configuration. A plurality of vessels **2** may be spaced apart height wise on the vertical supports **12** to create stacked levels or shelves of vessels **2**.

A roof cover **24** is supported by the vertical supports **12** to protect the plants contained within the vessels **2** from direct sunlight. The support structure **11** is secured to the ground via a base **15**, such as one or more stakes **25**.

With reference to **FIG. 7**, a side view of an agricultural apparatus **1** of the present invention in use is illustrated. Vessels **2** span the lengths between two vertical supports **12** creating an H-shaped configuration. A plurality of vessels **2** may be spaced apart height wise on the vertical supports **12** to create stacked levels or shelves of vessels **2**.

A roof cover **24** is supported by the vertical supports **12** to protect the plants contained within the vessels **2** from direct sunlight. The support structure **11** is secured to a floating base **26** that allows the agricultural apparatus **1** to be used on water or in swamps or marshes where stable land is not available for growing crops and/or supporting the agricultural apparatus **1** using normal anchoring means.

With reference to **FIG. 8**, a side view of an agricultural apparatus **1** having a plurality of vessels **2** arranged around a vertical support **12** in a circular configuration is illustrated. The vertical support **12** is placed centrally and supports a plurality of vessels **2** that are each attached

to the central support via attachment means **9**. The vessels **2** extend outward from the central vertical support **12** at angles in relation to each other. The support structure **11** and vessels **2** may be covered by a roof cover **24** to protect the contents of the vessels **2** from overexposure to sunlight and/or an exterior cover **27** to protect the contents of the vessels **2** from animals, insects and so forth. The exterior cover **27** may comprises, screen, mesh or equivalent material that allows air and sunlight through but prevents entry of animals and/or insects. The exterior cover **27** may be supported by the roof cover **24** and/or supported by an exterior support frame **28** which may be reflective. The support structure **11** and/or components thereof may be rotatable.

With reference to **FIG. 9**, a front view of a vessel **2** from an agricultural apparatus **1** of the present invention having an individual vessel cover **29** is illustrated. The vessel **2** is used to hold a substrate, such as dirt, and one or more plants. The vessel **2** is substantially rectangular-shaped and comprises a bottom panel **3**, front panel **4**, rear panel **5** and side panels **6**. An upper perimeter edge **7** of the vessel **2** may be folded or curled to provide a lip **8**. One or more attachment means **9**, such as clips **10**, are located on the vessel **2** and are used to attach the vessel **2** to a support structure **11**, as illustrated in **FIG. 3**. As illustrated herein, the clips **10** are located on the side panels **6** and extend from the upper perimeter edge **7** of the side panels **6** in an L-shaped fashion, thereby allowing the clips **10** to be placed over a horizontal support **13**, as illustrated in **FIG. 3**. However, attachment means **9**, such as clips **10**, may be located on front panel **4**, rear panel **5** and/or side panels **6**.

Cover supports **30** extend upward from the upper perimeter edge **7** of the vessel **2** and support the individual vessel covers **29** in an elevated position over the vessel **2**. The individual vessel cover **29** comprises an upper surface **31** and a lower surface **32**. The upper surface **31** is preferably a reflective surface **33** to prevent overheating of plants from direct overhead sunlight. One or more lights **34**, which may be solar powered LED lights, may be located on the lower surface **32** of the individual vessel cover **29** or any other surface of the agricultural apparatus **1**. The lights **34** are preferably powered by one or more rechargeable batteries powered by one or more solar panels, which are preferably incorporated into the individual vessel covers **29** and/or another surface of the agricultural apparatus **1**.

With reference to **FIG. 10**, a sectional side view along lines **A-A** of **FIG. 2** of a vessel **2** from an agricultural apparatus **1** of the present invention is illustrated. A liquid absorbent layer **14** is located on an inner surface of the bottom panel **3** of the vessel **2** to retain moisture for the plants

contained within the vessel **2**. One or more vent holes **15** may be located on the front panel **4**, rear panel **5** and/or side panels **6**, as illustrated in **FIG. 1**. A protective barrier **35**, such as a fiber, film, plastic, mesh, cloth and so forth, may line an inner surface of the front panel **4**, rear panel **5** and/or side panels **6**, thereby covering any vent holes **15** to prevent dirt or other substrate from escaping the vent holes **15**.

The agricultural apparatus **1** further comprises at least one irrigation drip line **36** having a distal end **37** located within the vessel **2** and a proximal end **38** connected to a reservoir **39** or other water source.

With reference to **FIG. 11**, a side perspective view of a support structure **11** of the present invention wherein vessels **2** are directly supported by multiple vertical supports **12** that are capable of being rolled for easy transportation of the support structure is illustrated. As illustrated herein, the support structure **11** comprises at least one vertical support **12**, which may be tubular-shaped for strength. The support structure **11** may be secured to the ground via a base **17**, such as anchoring brackets **18**, stakes, spikes, foundational supports, weights, feet, and so forth, which stabilize the support structure **11** in an upright position. The support structure **11** may be placed on a variety of surfaces, such as hard surfaces, dirt, swamp, marsh, water and so forth. As illustrated herein, the support structure **11** comprises a plurality of rolling means **40**, such as wheels, casters and so forth, located on each of the at least one vertical support **12**.

Vessels **2** span the lengths between two vertical supports **12** creating an H-shaped configuration. The vessels **2** are secured to the vertical supports **12** via an attachment means **9**, such as support brackets **19**. The support brackets **19** illustrated herein comprise two halves wherein a first half **20** is a vertical tube **21** and the second half **22** is a horizontal tube **23** integral to each other. The vertical tube **21** is placed over the vertical support **11** and the horizontal tube **23** is placed over the vessel **2**. A plurality of vessels **2** may be spaced apart height wise on the at least one vertical support **12** to create stacked levels of vessels **2**.

At least one suspension means **41**, such as a cable, bracket and so forth, extends upward from the agricultural apparatus **1** and provides an attachment point for securing the agricultural apparatus **1** to a lifting device or for hanging the agricultural apparatus **1** in an elevated position

With reference to **FIG. 12**, a partial side view of an agricultural apparatus **1** having a plurality of vessels **2** arranged around a threaded vertical support **12** in a circular configuration is illustrated. The vertical support **12** may be threaded and engage a correspondingly threaded

support bracket **19**. The threaded vertical support **12** allows the height of the support bracket **19** to be adjusted.

It is to be understood that while a preferred embodiment of the invention is illustrated, it is not to be limited to the specific form or arrangement of parts herein described and shown. It will
5 be apparent to those skilled in the art that various changes may be made without departing from the scope of the invention and the invention is not to be considered limited to what is shown and described in the specification and drawings.

10

15

20

25

30

CLAIMS

Please amend the claims as follows:

1. An agricultural apparatus for growing plants comprising:
a support structure having at least one elongated vertical support extending upward from a base;
a plurality of vessels secured to the support structure via attachment means;
said plurality of vessels being spaced apart vertically on the support structure;
each of said plurality of vessels is rectangular-shaped and comprises a bottom panel, front panel, rear panel and side panels;
each of said plurality of vessels is supported by the at least one vertical support;
said attachment means attaching said plurality of vessels to said at least one vertical support comprises at least one attachment bracket; and
at least one support bracket having two halves wherein a first half is a vertical tube and a second half is a horizontal tube wherein the vertical tube is placed over the at least one vertical support and the horizontal tube is placed over a vessel being attached to the at least one vertical support.
2. The agricultural apparatus of claim 1 further comprising:
a plurality of horizontal supports spaced apart at various heights on the at least one vertical support of the support structure.
3. The agricultural apparatus of claim 2 wherein:
each of said plurality of vessels is rectangular-shaped and comprises a bottom panel, front panel, rear panel and side panels; and
each of said plurality of vessels is supported by the plurality of horizontal supports.

4. The agricultural apparatus of claim 1 wherein:
an upper perimeter edge of each vessel is folded to provide a lip.
5. The agricultural apparatus of claim 1 wherein:
each vessel further comprises a liquid absorbent layer located on the bottom panel.
6. The agricultural apparatus of claim 1 wherein:
each vessel further comprises at least one vent hole.
7. The agricultural apparatus of claim 4 wherein:
each vessel further comprises at least one vent hole.
8. The agricultural apparatus of claim 1 wherein:
said plurality of vessels is supported by the plurality of horizontal supports and attached to said horizontal supports via clips.
9. The agricultural apparatus of claim 8 wherein:
said clips are L-shaped.
10. The agricultural apparatus of claim 1 further comprising:
a base that holds the support structure in an upright position.
11. The agricultural apparatus of claim 10 wherein:
said base is a floating base.
12. The agricultural apparatus of claim 1 wherein:
said plurality of vessels are arranged in a circular configuration within the support structure.
13. The agricultural apparatus of claim 1 wherein:
said support structure and plurality of vessels are arranged in a T-shaped configuration.
14. The agricultural apparatus of claim 1 wherein:

said support structure and plurality of vessels are arranged in an H-shaped configuration.

15. The agricultural apparatus of claim 1 further comprising:

a roof cover to protect plants contained within the vessels from direct sunlight.

16. The agricultural apparatus of claim 15 wherein:

said roof cover is reflective to protect plants contained within the vessels from direct sunlight.

17. The agricultural apparatus of claim 2 wherein:

said vertical supports are size adjustable; and

said horizontal supports are size adjustable.

18. The agricultural apparatus of claim 1 wherein:

each of said plurality of vessels is size adjustable.

19. The agricultural apparatus of claim 1 further comprising:

an exterior cover to protect plants contained within the vessels.

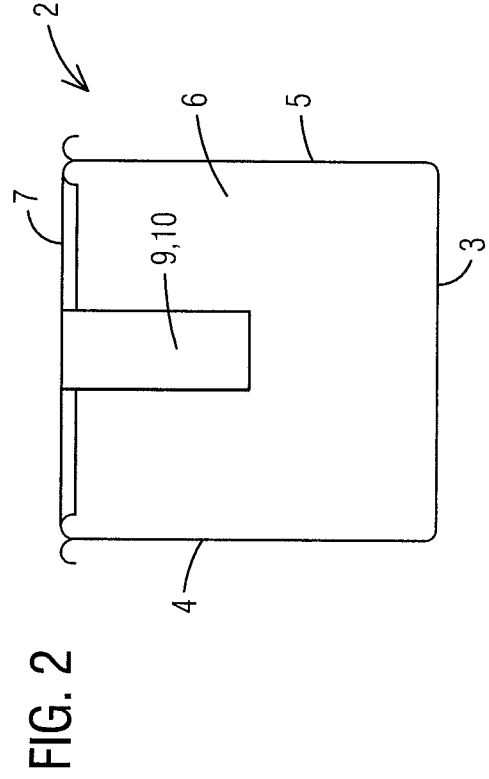
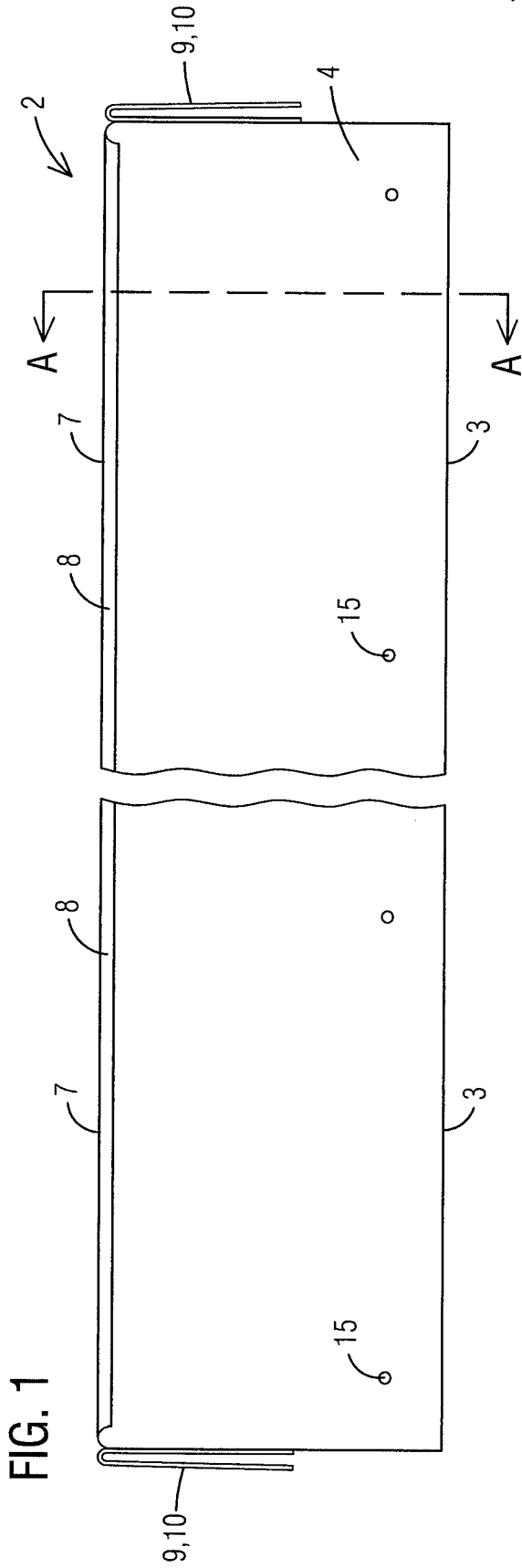

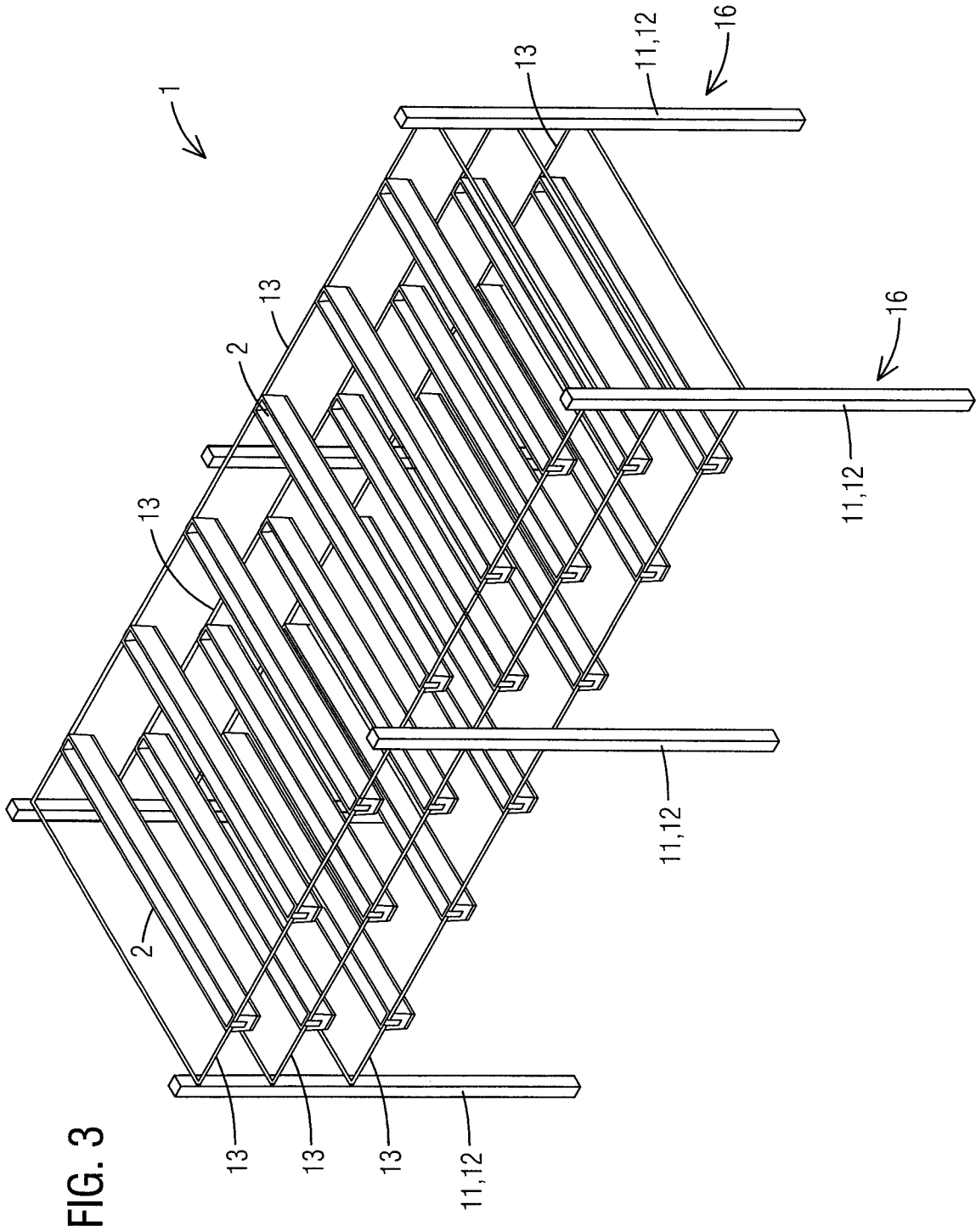

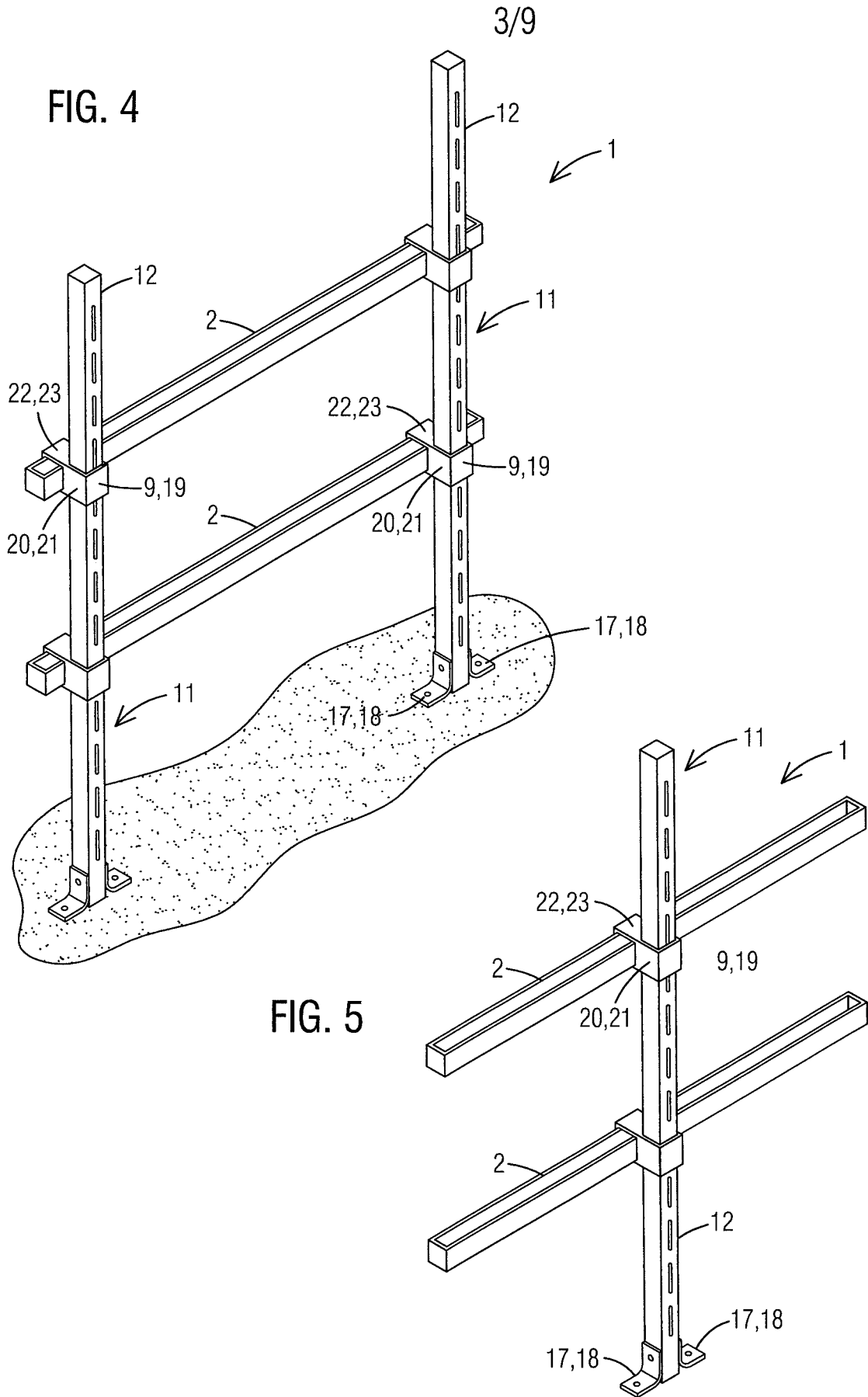

FIG. 6

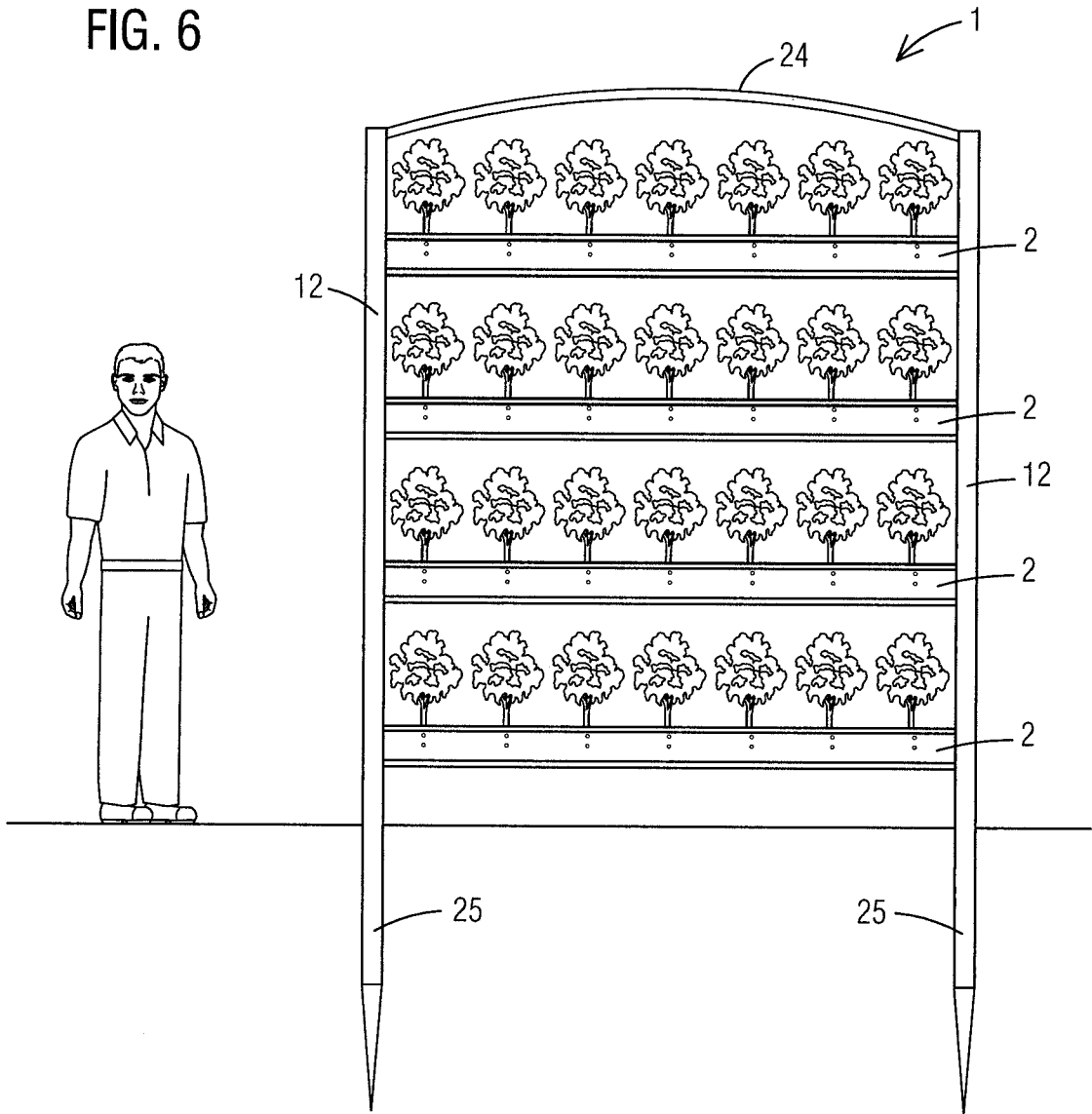

FIG. 7

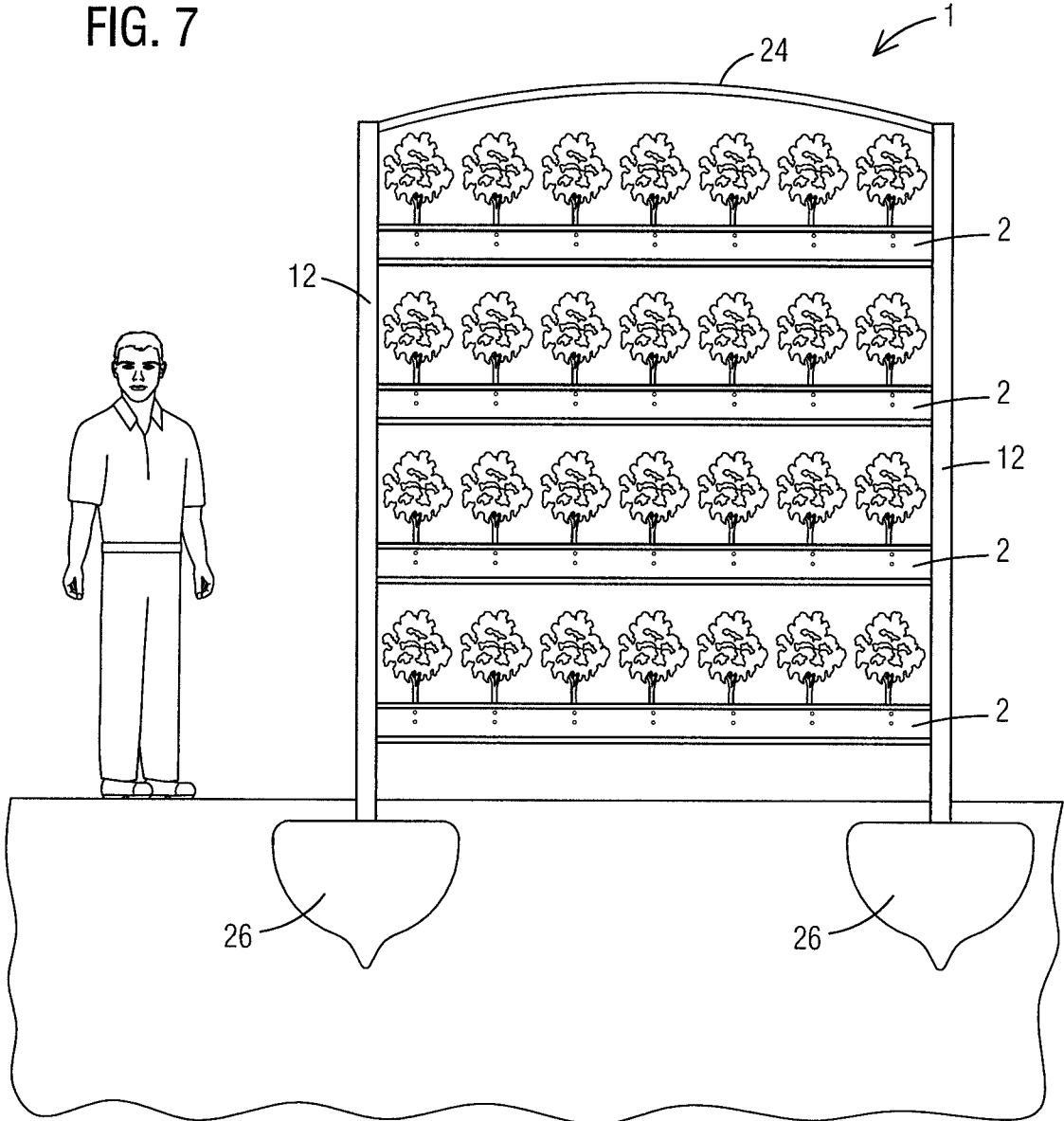
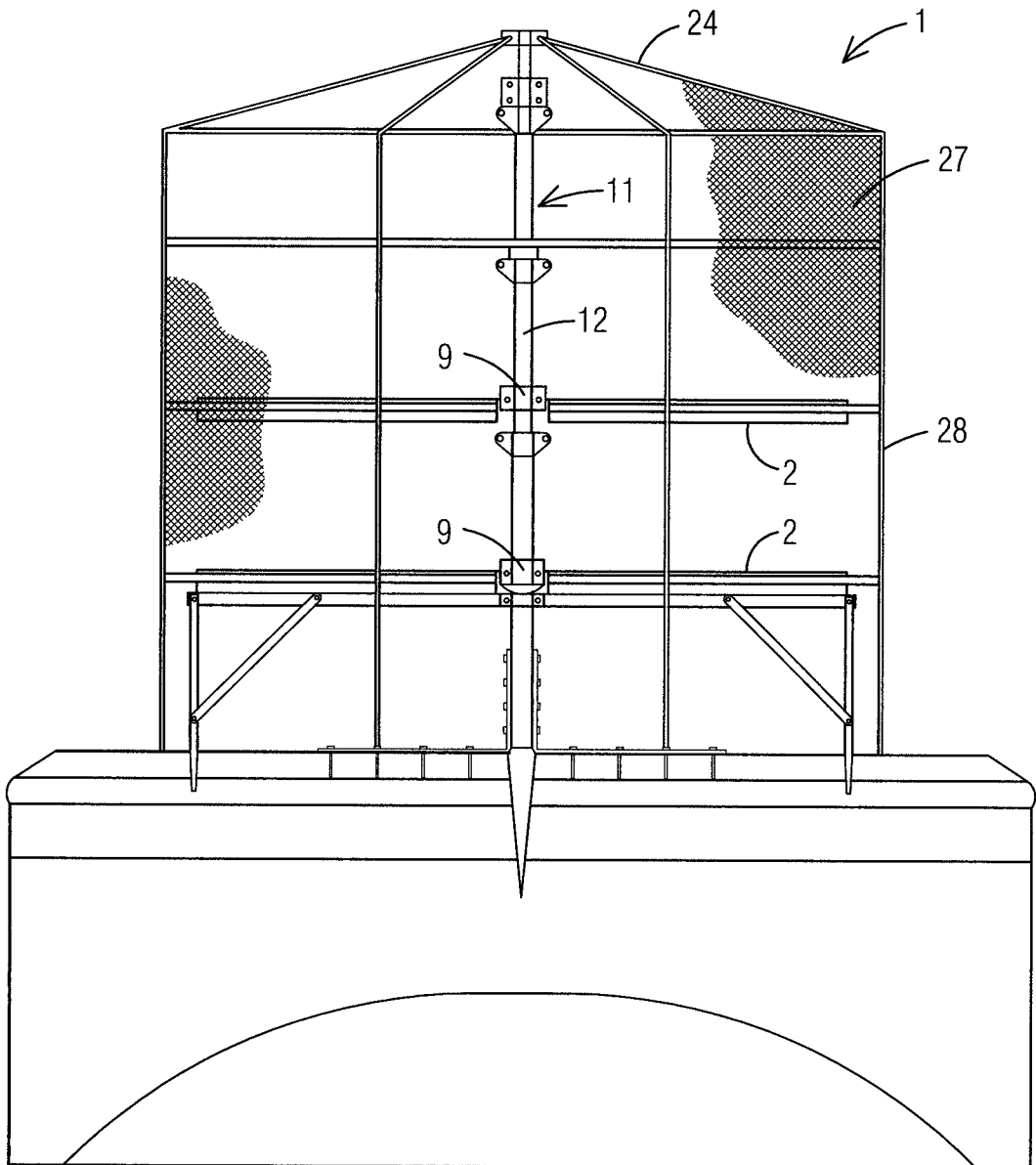

FIG. 8



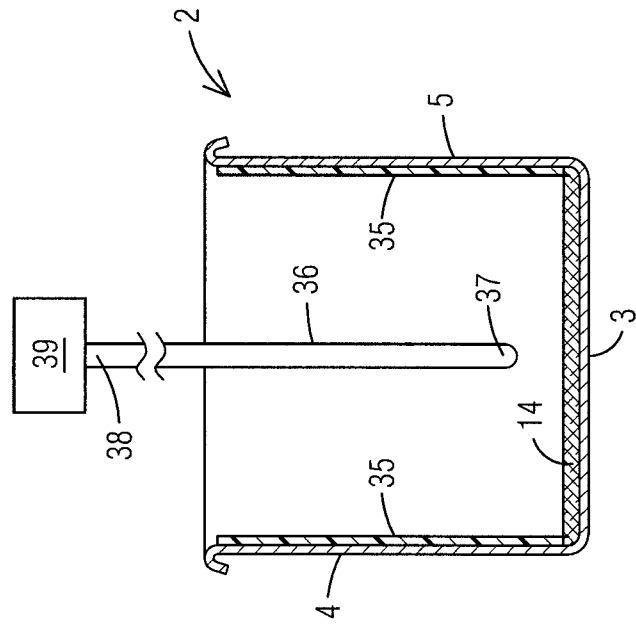

FIG. 10

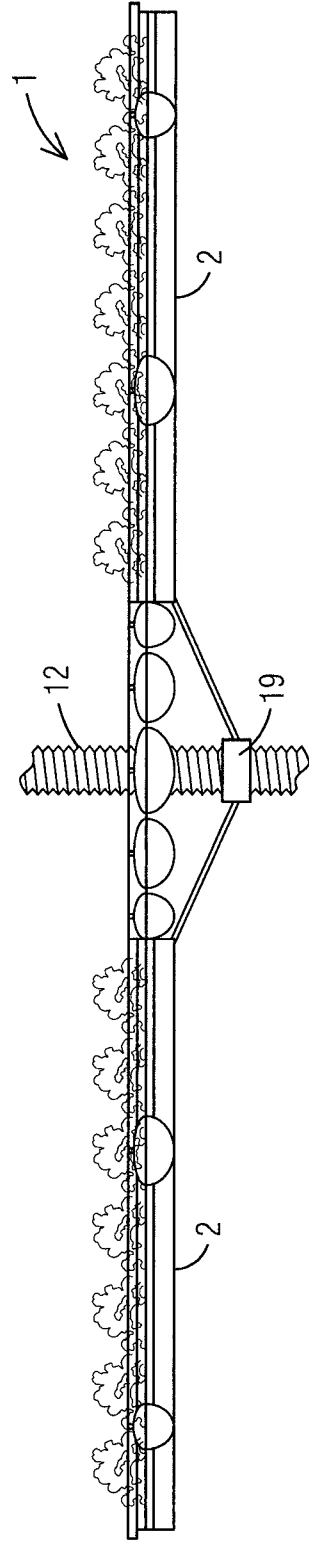

FIG. 12

FIG. 11

