

Dec. 19, 1939.

J. N. BURDICK ET AL

2,183,639

EDUCATION DEVICE

Filed Jan. 6, 1937

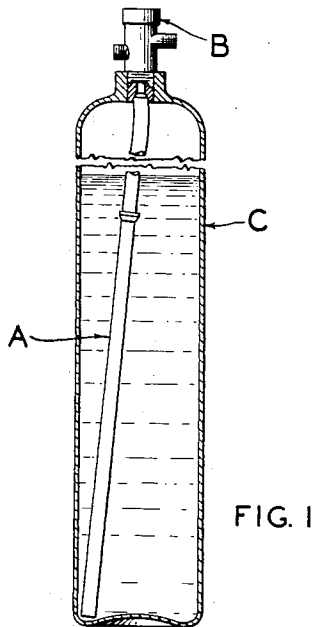

FIG. 1

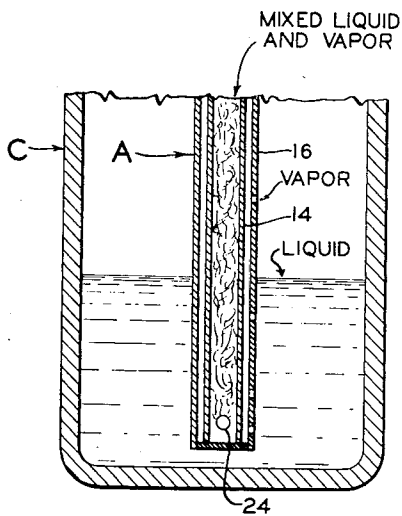

FIG. 3

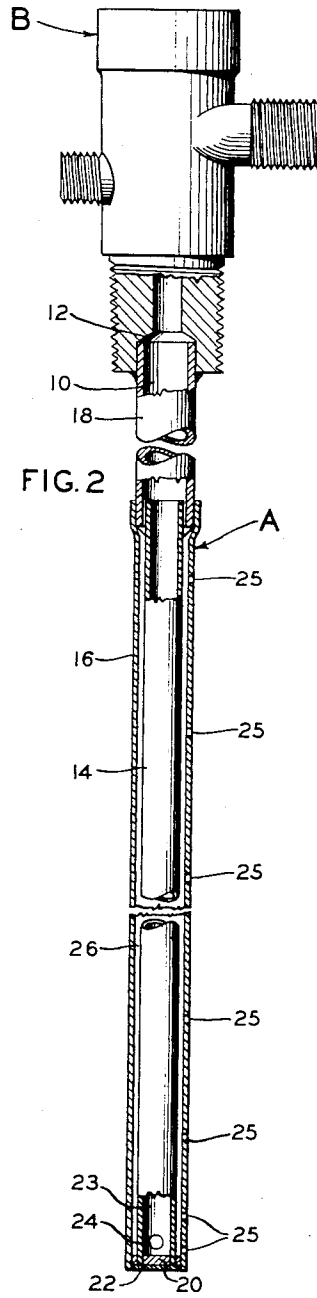

FIG. 2

INVENTORS
JOHN N. BURDICK AND
ERIC E. SOMMER
BY *E. E. Sommer*
ATTORNEY

UNITED STATES PATENT OFFICE

2,183,639

EDUCTION DEVICE

John N. Burdick and Eric E. Sommer, Buffalo, N. Y., assignors to Carbide and Carbon Chemicals Corporation, a corporation of New York

Application January 6, 1937, Serial No. 119,285

11 Claims. (Cl. 62—1)

The invention pertains to eduction devices and more particularly to an eductor for removing a substantially uniform composition of a compressed mixture of at least partially liquefied gases of different vapor tensions from a container in which they are confined under pressure.

An example of such a composition or mixture is one containing carbon dioxide and ethylene oxide in the approximate proportion of 10 parts of the former to 1 part of the latter. This material is handled in conventional pressure vessels, for example cylinders such as those used for the transportation of oxygen, and under normal conditions the cylinders are approximately half full of the liquid phase of the mixture which is under about 600 pounds pressure. Due to the widely different vapor tensions of the two components the vapor phase is largely carbon dioxide while the liquid phase is a mixture of the two components having a higher ethylene oxide content than the average of the entire content of the cylinder.

The mixture under discussion is used as a fumigant and under some conditions one cylinder may be used for several fumigation operations. To be most effective and free from fire hazard the proportion of the mixture used for each fumigation should be substantially that of the entire content of the cylinder. Therefore, one of the objects of the invention is to provide an eductor tube that will remove a substantially uniform proportion of a compressed mixture of a plurality of partially liquefied gases having different vapor tensions from a cylinder in which it is contained. Other aims, objects, and novel features may be obtained from the following description and the accompanying drawing in which:

Fig. 1 is a longitudinal section through a cylinder having an outlet valve and an eductor attached thereto.

Fig. 2 is a view in partial section of the eductor and part of the valve shown in Fig. 1, and

Fig. 3 is a sectional view of the lower part of the eductor and a flat bottomed cylinder showing the action of the mixture during withdrawal.

In an eductor, such as those employed heretofore, the lower end was closed and the side provided with suitable openings through which the contents of the cylinder were discharged. When such a tube was provided with a single opening near the bottom, liquid only was removed with the result that the residual liquid became richer in ethylene oxide until an inflammable mixture might be discharged. Also,

when such an eductor was provided with a plurality of openings, of which one was in the vapor phase at least during a portion of the discharge, a slow rate of discharge then discharged only gas and this also left an inflammable residue. We have found however that the inflammability of the discharged gases or mixture may be practically or entirely eliminated by discharging the mixture through a jacketed eductor tube having openings of suitable size and location in both the inner tube and the outer jacket.

One embodiment of the invention shown by the above-mentioned drawing may comprise an eductor secured in the inner end of an opening through a conventional valve B that closes an opening in the upper end of a conventional pressure vessel or cylinder C. The cylinder C may be of the type usually employed for containing oxygen under high pressure and the valve B may be removably secured in the upper end or neck thereof by suitable interfitting threads in a conventional manner.

The eductor A may be disposed vertically within the cylinder C and extend from the valve B downward substantially to the bottom, and the upper end of the eductor may be secured to the valve B in a suitable manner. For example, a suitable portion 10 of the upper end of the tubular eductor A may be disposed in a suitable recess 12 in the lower end of the valve B and the joint between the eductor and the valve may be closed and further secured by suitable means such as solder. Thus the upper end of the fluid passage through the eductor may be connected with the inner end of the outlet passage through the valve B.

This improved eductor may comprise an inner tube 14 which may be surrounded by a jacket or outer tube 16. These concentric tubes may extend from the bottom of the cylinder C to the lower portion of the valve B, but since it has been found desirable to bend the eductor tube so that the lower end will be disposed in the lowermost portion of the cylinder, which is near the side wall, the upper portion of the eductor may comprise a single tube 18 which is more easily bent. Therefore, the upper portion of the eductor may consist of a single tube 18 while the lower portion may consist of concentric tubes 14 and 16. The upper tube 18 may be secured to the lower end of the valve B in the manner already described. The inner tube 14 may be secured within the lower end of the tube 18 by a fluid-tight joint, and the outer tube or jacket 16 may be secured to the outside of the lower

end of tube 18 by a similar joint. In the construction shown, the upper end of tube 16 is enlarged slightly so that it will fit over the lower end of tube 18 and the joints between the upper tube 18 and the lower tubes 14 and 16 may be further sealed or secured by suitable means such as a solder of which silver solder is preferred. The lower ends of the tubes 14 and 16 may be closed by suitable means such as a plug 20 secured in the lower end of the inner tube 14 and a ring 22 secured in the annular opening between the lower ends of the tubes 14 and 16. These closures numbers 20 and 22 may also be secured in place by any suitable means such as a solder.

The length of the upper tube 18 with respect to the lower tubes 14 and 16 may vary according to the character of the mixture being discharged and the location of the tubes 14 and 16. However, for the mixture described hereinbefore the length of the tubes 14 and 16 may be somewhat greater than half the interior height of the cylinder. Although the conducting capacity or cross-sectional area of the interior of the eductor may vary according to various conditions of usage, excellent results have been obtained from a tube 14 having an inner chamber 23 with a capacity somewhat greater than the capacity of the outlet through the valve B, and an outer tube or jacket 16 of such a size that the capacity of the annular area or outer chamber 26 between the tubes 14 and 16 is somewhat greater or about twice the capacity of the chamber 23.

The fluid passage through the inner tube 14 may be provided with an inlet adjacent the bottom of the container. This inlet may comprise two openings 24 which may be located in opposite sides of the tube 14 closely adjacent to bottom wall 20 and have a combined area or capacity substantially equal to the interior area or capacity of the tube 14. To withdraw a substantially uniform mixture of the contained gases at normal rates of discharge the outer tube or jacket 16 may be provided with a plurality of openings in the outer wall thereof. These openings 25 may be spaced vertically one above the other, with the lowermost hole or opening as near the bottom wall 22 as commercially practicable, and the uppermost openings somewhat more than half the distance between the lower end of the eductor tube A and the lower end of the valve B. The openings 25 may have a vertical spacing that is substantially logarithmic with the distance between the openings increasing from the bottom upwards. Although the number of openings 25 may vary according to various conditions of usage, excellent results have been attained by employing seven openings, all in the liquid phase of the mixture when the cylinder is fully charged, and of such a size that their combined area or capacity is somewhat less than the interior area or capacity of the tube 14, so that under conditions of normal discharge there is a substantial pressure drop between the inside and outside of tube 16.

The location of the openings 25 may be such that changes in the liquid and vapor phase composition due to changes in liquid and vapor phase volume, as the cylinder is discharged, are compensated for by more of the openings appearing in the vapor phase and thus admitting more vapor phase into the discharge or central tube. The combined area of the openings 24 in the inner tube 14 may be sufficiently large to have a small enough pressure drop to drain either partly or completely the residue of liquid present in the

annular chamber 26 between the inner and outer tubes 14 and 16. At the same time the combined area of the inlets or openings 25 in the jacket or outer tube 16 may be sufficiently small to have a large enough pressure drop so that the liquid entering through them cannot completely fill the chamber 26. In consequence of this high pressure drop as soon as an opening is uncovered or opened to the vapor phase the vapor phase is forced through it and mixed with the liquid phase, so that the composition of the discharge remains substantially uniform.

Fig. 3 shows the condition in the eductor A during normal rates of discharge. Here, it will be observed, the pressure drop through the openings in the tube 16 is sufficiently low and the pressure drop through the opening in the tube 14 is sufficiently high so that very little or no liquid remains in the chamber 26. When a standard cylinder containing approximately 66 pounds of a mixture of substantially 9 per cent ethylene oxide and 90 per cent carbon dioxide is discharged through this improved eductor under unfavorable conditions, such as a relatively high temperature of 100° F. and a relatively slow discharge rate of about 60 minutes to the contents of the cylinder, the maximum ethylene oxide content of the discharged gas is substantially 11.7 per cent. This is below the inflammable limit of 12.3 per cent ethylene oxide in an air mixture and is much lower than the ethylene oxide content of the discharged gas when prior eductor tubes are employed. For example, when using a prior three hole eductor tube under the same condition the maximum ethylene oxide content of the discharged gas would be over 20 per cent. Therefore, it appears that the present invention achieves a decided advance in the accuracy and safety of devices for educting mixtures of liquefied gases from cylinders.

Although a preferred embodiment of this invention is disclosed, it will be clear that this general method of eduction may be applied to apparatus having component parts of different size and in different relative locations without departing from the principle of the invention or sacrificing its advantages.

We claim:

1. Means for educting a uniform mixture of compressed liquefied gases having different vapor tensions from a pressure vessel container, comprising; an eductor within said vessel having an inner and outer chamber formed by a tube enclosed in a concentric jacket member, said jacket member being spaced from said tube to provide in said outer chamber a capacity substantially twice that of said inner chamber; means connecting the inner chamber provided by said tube with the outlet of said vessel; vertically spaced outlet openings in the otherwise impervious wall of said jacket member, and fluid communication between the inner and outer chamber in the lower end of said tube.

2. Means for educting a uniform mixture of compressed liquefied gases having different vapor tensions from a pressure vessel container, comprising; an eductor within said vessel having an inner and outer chamber formed by a tube enclosed in a spaced jacket member; means connecting the inner chamber provided by said tube with the outlet of said vessel; inlet openings in the otherwise impervious wall of said jacket member in vertical logarithmic position with the distance between adjacent openings increasing from the bottom upwardly; and fluid communication

between the inner and outer chamber at the lower end of said tube.

3. Means for educting a uniform mixture of compressed liquefied gases having different vapor tensions from a pressure vessel container, comprising; an eductor within said vessel having an inner and outer chamber formed by a tube enclosed in a spaced jacket member; means connecting the inner chamber provided by said tube with the outlet of said vessel; vertically spaced inlet openings in the otherwise impervious wall of said jacket member, and fluid communication between the inner and outer chamber at the lower end of said tube; the construction and arrangement of the parts being such that the pressure drop through the opening in the lower end of said tube is sufficiently low to drain substantially all of the liquid from the outer chamber during eduction, and the pressure drop through the openings in said jacket is sufficiently high so that the liquid entering through them cannot completely fill said outer chamber during eduction.

4. An eductor, for removing a uniform mixture of two or more liquefied gases from a cylinder in which they are confined under pressure, comprising; an upper tube having the upper end thereof secured in the outlet of said cylinder; an inner tube having the upper end thereof secured in the lower end of said upper tube, and the lower end thereof adjacent the bottom of said cylinder; an outer tube spaced from and coextensive with said inner tube with the upper end thereof secured around the lower end of said upper tube; means closing the lower ends of both said inner tube and said outer tube; said inner tube being provided with an inlet adjacent the lower end thereof; and said outer tube being provided with a plurality of vertically spaced inlets.

5. The invention defined by claim 4 in which the cross-sectional area of the said interior tube is somewhat greater than that of said outlet.

6. The invention defined by claim 4 in which the area of the inlet opening in the said inner tube is substantially the same as the cross-sectional area of the interior thereof.

7. The invention defined by claim 4 in which the cross-sectional area of the annular opening between said inner tube and said outer tube is substantially twice the cross-sectional area of the interior of said inner tube.

8. The invention defined by claim 4 in which the combined area of the inlets in said outer tube is substantially less than the area of the inlet in said inner tube.

9. The invention defined by claim 4 in which said upper tube is bendable and is capable of being bent to position the lower end of the eductor in the lowermost portion of the cylinder.

10. The invention defined by claim 4 in which said outer tube is provided with seven inlet openings with the lowermost substantially at the bottom of said outer tube, and the spacing between said openings is logarithmic.

11. An eductor, for removing a uniform mixture of two or more liquefied gases from a cylinder in which they are confined under pressure, comprising; two chambers connected by a suitable opening adjacent the bottom of said cylinder; one of said chambers being provided with a suitable connection between the upper end thereof and the outlet of said cylinder, and the other of said chambers being provided with a plurality of vertically spaced inlet openings, the spacing between said openings being logarithmic and upwardly progressing.

JOHN N. BURDICK,
ERIC E. SOMMER.