



- (51) International Patent Classification:  
*H01P 1/208* (2006.01) *H01P 7/10* (2006.01)
- (21) International Application Number:  
PCT/GB2016/051183
- (22) International Filing Date:  
27 April 2016 (27.04.2016)
- (25) Filing Language: English
- (26) Publication Language: English
- (30) Priority Data:  
1507249.9 28 April 2015 (28.04.2015) GB  
1507247.3 28 April 2015 (28.04.2015) GB
- (72) Inventor; and  
(71) Applicant : RHODES, David [GB/GB]; Dabarda, West  
Winds, Moor Lane, Menston Yorkshire LS29 6QD (GB).
- (74) Agent: HEPWORTH BROWNE; 7 Wragley House, Val-  
ley Road, Hebden Bridge Yorkshire HX7 7BN (GB).
- (81) Designated States (unless otherwise indicated, for every  
kind of national protection available): AE, AG, AL, AM,  
AO, AT, AU, AZ, BA, BB, BG, BH, BN, BR, BW, BY,

BZ, CA, CH, CL, CN, CO, CR, CU, CZ, DE, DK, DM,  
DO, DZ, EC, EE, EG, ES, FI, GB, GD, GE, GH, GM, GT,  
HN, HR, HU, ID, IL, IN, IR, IS, JP, KE, KG, KN, KP, KR,  
KZ, LA, LC, LK, LR, LS, LU, LY, MA, MD, ME, MG,  
MK, MN, MW, MX, MY, MZ, NA, NG, NI, NO, NZ, OM,  
PA, PE, PG, PH, PL, PT, QA, RO, RS, RU, RW, SA, SC,  
SD, SE, SG, SK, SL, SM, ST, SV, SY, TH, TJ, TM, TN,  
TR, TT, TZ, UA, UG, US, UZ, VC, VN, ZA, ZM, ZW.

- (84) Designated States (unless otherwise indicated, for every  
kind of regional protection available): ARIPO (BW, GH,  
GM, KE, LR, LS, MW, MZ, NA, RW, SD, SL, ST, SZ,  
TZ, UG, ZM, ZW), Eurasian (AM, AZ, BY, KG, KZ, RU,  
TJ, TM), European (AL, AT, BE, BG, CH, CY, CZ, DE,  
DK, EE, ES, FI, FR, GB, GR, HR, HU, IE, IS, IT, LT, LU,  
LV, MC, MK, MT, NL, NO, PL, PT, RO, RS, SE, SI, SK,  
SM, TR), OAPI (BF, BJ, CF, CG, CI, CM, GA, GN, GQ,  
GW, KM, ML, MR, NE, SN, TD, TG).

**Published:**

- without international search report and to be republished  
upon receipt of that report (Rule 48.2(g))

(54) Title: A TUNEABLE TEM MODE MICROWAVE RESONATOR AND A TUNEABLE MICROWAVE FILTER

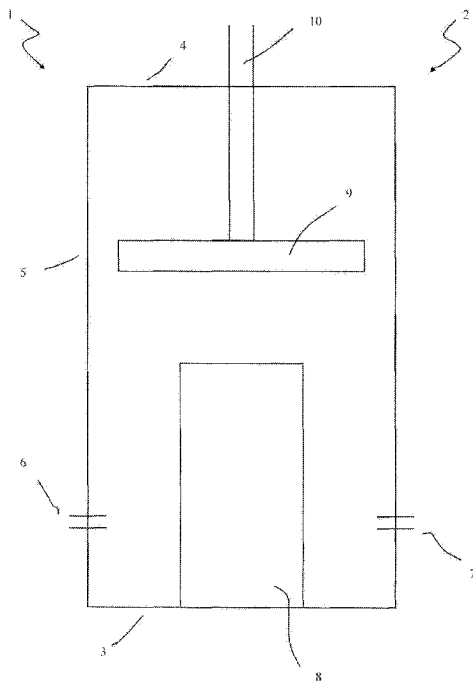

Figure 1

(57) Abstract: A tuneable TEM mode microwave resonator comprising an electrically conducting resonator cavity comprising first and second spaced apart end faces and a cavity side wall extending therebetween; an electrically conducting resonator body arranged within the resonator cavity and extending from the first end face part way to the second end face and spaced apart from the cavity side wall, the end of the resonator body remote from the first end face having a recess therein extending part way along the length of the resonator body, the bottom of the recess being defined by a recess base, the recess having a recess side wall extending from the recess base to a recess mouth in the end of the resonator body remote from the first end face; an electrically conducting cup side wall extending from the second end face part way to the resonator body to define a cup having a cup base and a cup mouth; the cup mouth and recess mouth being arranged about a common displacement axis; an air gap extending from the base of the cup to the base of the recess, the air gap between the mouth of the cup and the mouth of the recess being bound by the cavity side wall; and, a dielectric body arranged on the common displacement axis between the base of the recess and the base of the cup, the dielectric body being arranged at least partially within the recess and being adapted to be displaced along the displacement axis between a first position outside the cup and a second position where it is received by the mouth of the cup; the dielectric body having a length L along the displacement axis, the distance between the base of the cup and the recess mouth being less than L.

## A tuneable TEM mode microwave resonator and a tuneable microwave filter

The present invention relates to a tuneable TEM mode microwave resonator. More particularly, but not exclusively, the present invention relates to a tuneable TEM mode microwave resonator comprising a resonator cavity having a resonator body extending from a first face and a cup wall extending from a second face opposite the first face and defining a cup having a cup mouth and a cup base, the resonator further comprising a dielectric body within the cavity and adapted to be displaced between a recess in the resonator body towards and away from the cup, the length of the dielectric body being greater than the distance between the base of the cup and the mouth of the resonator body. The present invention also relates to a tuneable microwave filter. More particularly, but not exclusively the present invention relates to a tuneable microwave filter comprising a plurality of such resonators being electrically coupled together, each resonator being electrically coupled to at least one other resonator.

Tuneable microwave filters comprising a plurality of tuneable microwave resonators are known. In use one adjusts the resonant frequency of one or more of the resonators to adjust the bandpass of the filter. The problem with such known tuneable microwave filters is that the resonators can only be adjusted over a relatively narrow frequency range which makes them unsuitable for modern applications. Further, the resonant frequency of such known resonators varies in a non-linear fashion making them hard to tune.

GB1214130.5 discloses a TM mode resonator. The TM mode resonator comprises a resonator cavity having first and second faces. A resonator body extends from the first face and a cup extends from the second face. The cup and the resonator body are arranged on a common displacement axis. A ceramic spacer extends between the resonator body and cup. A dielectric tuning screw extends along an aperture which extends through the entirety of the length of the resonator body, then through the ceramic spacer and into the cup. The electric field distribution in this resonator is very different to that of the current invention. This resonator can only be tuned over a relatively narrow frequency range. Further, the resonant frequency varies non-linearly with position of the tuning screw making it difficult to tune.

The present invention seeks to overcome the problems of the prior art.

Accordingly, in a first aspect, the present invention provides a tuneable TEM mode microwave resonator comprising

an electrically conducting resonator cavity comprising first and second spaced apart end faces and a cavity side wall extending therebetween;

an electrically conducting resonator body arranged within the resonator cavity and extending from the first end face part way to the second end face and spaced apart from the cavity side wall, the end of the resonator body remote from the first end face having a recess therein extending part way along the length of the resonator body, the bottom of the recess being defined by a recess base, the recess having a recess side wall extending from the recess base to a recess mouth in the end of the resonator body remote from the first end face;

an electrically conducting cup side wall extending from the second end face part way to the resonator body to define a cup having a cup base and a cup mouth;

the cup mouth and recess mouth being arranged about a common displacement axis;

an air gap extending from the base of the cup to the base of the recess, the air gap between the mouth of the cup and the mouth of the recess being bound by the cavity side wall; and,

a dielectric body arranged on the common displacement axis between the base of the recess and the base of the cup, the dielectric body being arranged at least partially within the recess and being adapted to be displaced along the displacement axis between a first position outside the cup and a second position where it is received by the mouth of the cup;

the dielectric body having a length  $L$  along the displacement axis, the distance between the base of the cup and the recess mouth being less than  $L$ .

The tuneable TEM mode microwave resonator according to the invention can be tuned over a much wider range of frequencies than known microwave resonators. It can therefore be employed in filters which can in turn be tuned over a much wider range of frequencies than known filters. Further, the resonant frequency of the resonator varies linearly with position of the dielectric body over a wide frequency range making it easier to tune than known tuneable resonators.

Preferably the base of the cup is a portion of the second end face.

Preferably the dielectric body is cylindrical

Preferably the tuneable TEM mode resonator as further comprising a connector arm connected to the dielectric body and extending along the displacement axis out of the cavity.

Preferably the tuneable TEM mode resonator further comprises a conduit extending from the first face to the base of the recess, the connector arm extending through the conduit.

Preferably the tuneable TEM mode microwave resonator further comprises an electrically conducting matching bar arranged within the cavity and extending from the first face part way towards the second face, parallel to and spaced apart from the resonator body; and,  
a signal line extending from the end of the matching bar remote from the first end face out of the cavity.

Preferably the tuneable microwave resonator further comprising an inductor connected at one end to the resonator body part way along the length of the resonator body, the inductor extending out of the resonator cavity.

In a further aspect of the invention there is provided a tuneable TEM mode microwave filter comprising a plurality of tuneable microwave resonators as claimed in any one of claims 1 to 7, each resonator being coupled to at least one other resonator, coupled resonators being coupled together by means of a shared side wall having an aperture extending therethrough.

Preferably all the resonators are identical.

The present invention will now be described by way of example only and not in any limitative sense with reference to the accompanying drawings in which

Figure 1 shows a known tuneable microwave resonator in cross section;

Figure 2 shows a tuneable microwave resonator according to the invention in cross section;

Figure 3 shows a microwave filter according to the invention in plan view; and,

Figure 4 shows an alternative embodiment of a microwave filter according to the invention in plan view.

Shown in figure 1 is a known tuneable microwave resonator 1. The tuneable microwave resonator 1 comprises an electrically conducting resonator cavity 2. The resonator cavity 2 comprises first and second spaced apart end faces 3,4 with a side wall 5 extending therebetween. The side wall 5 comprises entrance and exit apertures 6,7 through which microwaves can enter and exit the cavity 2. Arranged within the cavity 2 is an electrically conducting resonator body 8. The resonator body 8 extends from the first end face 3 partially toward the second end face 4. Further arranged in the cavity 2 between the end of the resonator body 8 and the second end face 4 is a dielectric body 9. A connection arm 10 extends from the dielectric body 9, through the second end face 4 and out of the cavity 2. By displacing the connection arm 10 one can displace the dielectric body 9 towards and away from the second end face 4, so adjusting the resonant frequency of the resonator cavity 2.

A problem with such known resonators 1 is that displacement of the dielectric body 9 only tunes the resonator 1 over a relatively narrow range of frequencies. Such resonators 1 are therefore unsuitable for use in filters which are required to have a bandpass which can be tuned over a wide frequency range.

Shown in figure 2 in cross section is a tuneable TEM mode microwave resonator 20 according to the invention. The tuneable TEM mode microwave resonator 20 comprises an electrically conducting resonator cavity 21 comprising first and second spaced apart end faces 22,23 and a cavity side wall 24 extending therebetween. The cavity side wall 24 comprises entrance and exit apertures 25,26 through which microwaves can enter and exit the cavity 21.

Arranged within the cavity 21 is an electrically conducting resonator body 27. The resonator body 27 extends along a displacement axis 33 from the first face 22 part way towards the second face 23 and is spaced apart from the cavity side wall 24. The end of the resonator body 27 remote from the first end face 22 has a recess 28 therein which extends part way along the resonator body. The entrance to the recess 28 is defined by a recess mouth 29. The bottom of the recess 28 is defined by a recess base 30. A recess side wall extends between the two. The mouth 29 of the recess 28 is arranged symmetrically about the displacement axis 33.

Also arranged within the resonator cavity 21 is a dielectric body 30. The dielectric body 30 is received at least partially within the recess 28 as shown. The dielectric body 30 typically has a dielectric constant in the range 20 – 100. A small conduit extends from the first face along the displacement axis 33 to the base 30 of the recess. Extending from the dielectric body 30 and out of the resonator cavity 21 is a connector arm 31. A displacement mechanism 32 outside the resonator cavity 21 is connected to the connector arm 31. By moving the connector arm 31 along its length the displacement mechanism 32 can displace the dielectric body 30 along a displacement axis 33. This moves the dielectric body 30 towards and away from the recess base 30. The dielectric body 30 is typically cylindrical with the displacement axis 33 running along the axis of symmetry of the cylinder. The bottom edge of the dielectric body is substantially parallel to the recess base 30. The range of motion of the dielectric body 30 by the bottom edge of the dielectric body 30 abutting the base 30 of the recess 28.

Extending from the second end face 23 part way to the resonator body 27 is a cup side wall 36. The cup side wall 36 defines a cup 34 having a cup mouth 37 and a cup base 35. The cup base 35 is a portion of the second end face 23. The cup mouth 37 is dimensioned to receive the resonator body

30 and is centred about the displacement axis 33. The range of motion of the resonator body 30 towards the second end face 23 is limited by the resonator body 30 abutting the cup base 35.

Extending from the base 35 of the cup 34 to the base 30 of the recess is an air gap. Between the mouth 37 of the cup 34 and the mouth 29 of the recess 28 the air gap is laterally bounded by the cavity side wall 24.

The dielectric body 30 has a length  $L$  along the displacement axis 33. The distance between the recess mouth 29 and the base 35 of the cup 34 is less than  $L$ . This ensures that as the dielectric body 30 is displaced along the displacement axis 33 it is always received at least partially in the recess 28 of the resonator body 27. The distance between the cup mouth and the base of the recess is greater than  $L$  so that the resonator body can be removed from the cup.

The dielectric body 30 is shown in figure 2 in a first position in which it is partially received in the recess 28 of the resonator body 27 but not received in the cup. In order to tune the resonator 20 the dielectric body 30 is displaced upwards (ie towards the second end face 23) along the displacement axis 33. As the dielectric body 30 is displaced upwards the top of the dielectric body 30 enters the mouth 37 of the cup 34 and approaches the base of the cup 34 so arriving at a second position. Simultaneously the bottom of the dielectric body 30 moves away from the base of the recess 28 but is still in the recess 28 of the resonator body 27 when the dielectric body 30 arrives at the second position. The increase in coupling between the dielectric body 30 and the cup 34 along with simultaneous decrease in coupling between the dielectric body 30 and resonator body 27 as the dielectric body 30 moves from the first position to the second position ensures linear tuning of the TEM mode resonator as a function of the position of the resonator body 30. It also enables the microwave TEM mode resonator according to the invention to be tuned over a much wider frequency range than known microwave frequency resonators. The TEM mode resonator can of course also be tuned by displacing the dielectric body in the opposite direction.

Shown in figure 3 is tuneable microwave filter 40 according to the invention in plan view. The tuneable microwave filter 40 comprises a plurality of TEM mode resonators 20 as previously described. Preferably the TEM mode resonators 20 are identical. The TEM mode resonators 20 are

electrically coupled together. In this embodiment the TEM mode resonators 20 are coupled together in a chain although other configurations are possible. Each TEM mode resonator 20 is electrically coupled to at least one other resonator in the chain.

Two resonators 20 that are coupled together share a side wall 24. An aperture 26 extends through the side wall 24 through which microwaves can pass. The size and shape of the aperture 26 determines the inter-resonator coupling which at least in part determines the properties of the filter 40. The inter-resonator coupling is typically adjusted by means of coupling screws which extend into the aperture 26.

In this embodiment the first resonator 20 has an electrically conducting matching bar 41 arranged within the resonator cavity 21. The matching bar 41 extends from the first end face 22 partially towards the second end face 23. The matching bar 41 is typically the same height as the resonator body 27 and is spaced apart therefrom. A signal line 42 extends from the end of the matching bar 41 remote from the first end face 22 out of the resonator cavity 21. The last resonator 20 in the chain also has an identical matching bar 41 and signal line 42 arrangement as shown. In use a microwave signal is provided to the filter 40 along the first signal line 42 and removed from the filter 40 on the second signal line 42.

The matching bar 41 essentially acts as a matching circuit. The admittance of the resonators 20 varies with frequency. The matching bar 41 ensures that the device sending a signal to the filter 40 or receiving a signal from the filter 40 sees a substantially frequency invariant filter admittance. The impedance of the matching bar 41 is set depending on the properties of the resonators 20, in particular the effective electrical length of the resonator body 27 over the range of frequencies the filter 40 is designed to be tuned over.

Shown in figure 4 is a further embodiment of a tuneable microwave filter 40 according to the invention. This is similar to that of figure 5 except rather than the first and last resonators 20 having matching bars 41 each comprises an inductor 43 connected to the resonator body 27 and extending out of the resonator cavity 21. Again, the inductor 43 acts as a matching circuit. The value of the inductor 43 is set depending on the properties of the resonators 20, in particular the effective

electrical length of the resonator body 27 over the range of frequencies the filter 40 is designed to be tuned over. The inductor 43 is typically connected to the resonator body 27 part way along the length of the resonator body 27. The point of connection is determined by the bandpass of the filter 40.

The above embodiment of the filter 40 comprises only one set of resonators 20 coupled together. The filter 40 may be a multiple bandpass filter in which case it comprises a plurality of groups of resonators 20, the resonators 20 in each group being connected together. In further alternative embodiments the filter 40 may be a multiplexer, more particularly a diplexer or triplexer.

## CLAIMS

1. A tuneable TEM mode microwave resonator comprising  
an electrically conducting resonator cavity comprising first and second spaced apart end faces and a cavity side wall extending therebetween;  
an electrically conducting resonator body arranged within the resonator cavity and extending from the first end face part way to the second end face and spaced apart from the cavity side wall, the end of the resonator body remote from the first end face having a recess therein extending part way along the length of the resonator body, the bottom of the recess being defined by a recess base, the recess having a recess side wall extending from the recess base to a recess mouth in the end of the resonator body remote from the first end face;  
an electrically conducting cup side wall extending from the second end face part way to the resonator body to define a cup having a cup base and a cup mouth;  
the cup mouth and recess mouth being arranged about a common displacement axis;  
an air gap extending from the base of the cup to the base of the recess, the air gap between the mouth of the cup and the mouth of the recess being bound by the cavity side wall; and,  
a dielectric body arranged on the common displacement axis between the base of the recess and the base of the cup, the dielectric body being arranged at least partially within the recess and being adapted to be displaced along the displacement axis between a first position outside the cup and a second position where it is received by the mouth of the cup;  
the dielectric body having a length  $L$  along the displacement axis, the distance between the base of the cup and the recess mouth being less than  $L$ .
2. A tuneable TEM mode resonator as claimed in claim 1, wherein the base of the cup is a portion of the second end face.

3. A tuneable TEM mode resonator as claimed in either of claims 1 or 2, wherein the dielectric body is cylindrical
4. A tuneable TEM mode resonator as claimed in any one of claims 1 to 3, further comprising a connector arm connected to the dielectric body and extending along the displacement axis out of the cavity.
5. A tuneable TEM mode resonator as claimed in claim 4, further comprising a conduit extending from the first face to the base of the recess, the connector arm extending through the conduit.
6. A tuneable TEM mode microwave resonator as claimed in any one of claims 1 to 5, further comprising an electrically conducting matching bar arranged within the cavity and extending from the first face part way towards the second face, parallel to and spaced apart from the resonator body; and,  
  
a signal line extending from the end of the matching bar remote from the first end face out of the cavity.
7. A tuneable microwave resonator as claimed in any one of claims 1 to 6, further comprising an inductor connected at one end to the resonator body part way along the length of the resonator body, the inductor extending out of the resonator cavity.
8. A tuneable microwave filter comprising a plurality of tuneable TEM mode microwave resonators as claimed in any one of claims 1 to 7, each resonator being coupled to at least one other resonator, coupled resonators being coupled together by means of a shared side wall having an aperture extending therethrough.
9. A tuneable microwave filter as claimed in claim 9, wherein all the resonators are identical.

10. A tuneable microwave resonator substantially as hereinbefore described.
  
11. A tuneable microwave filter substantially as hereinbefore described.

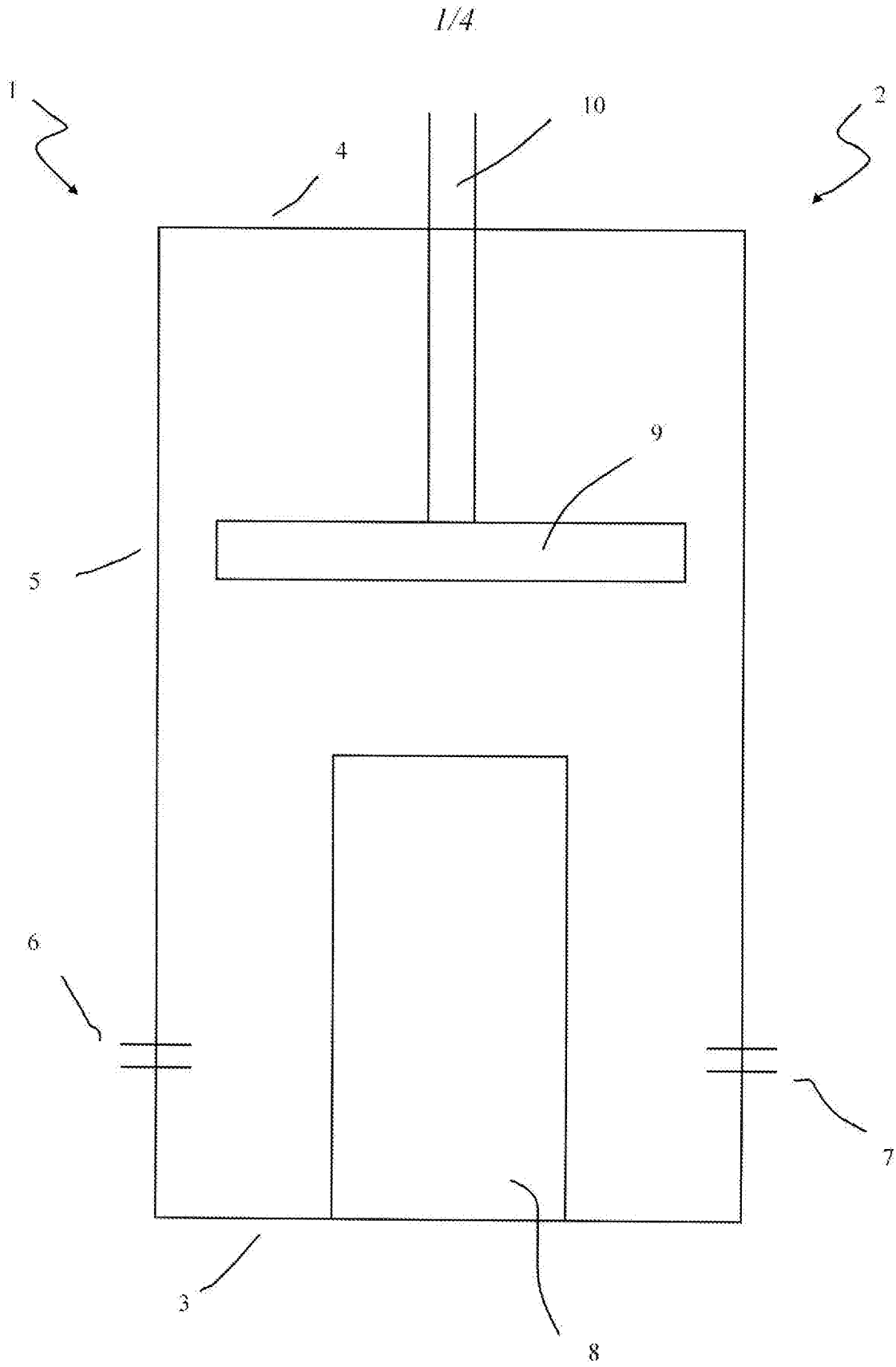

Figure 1

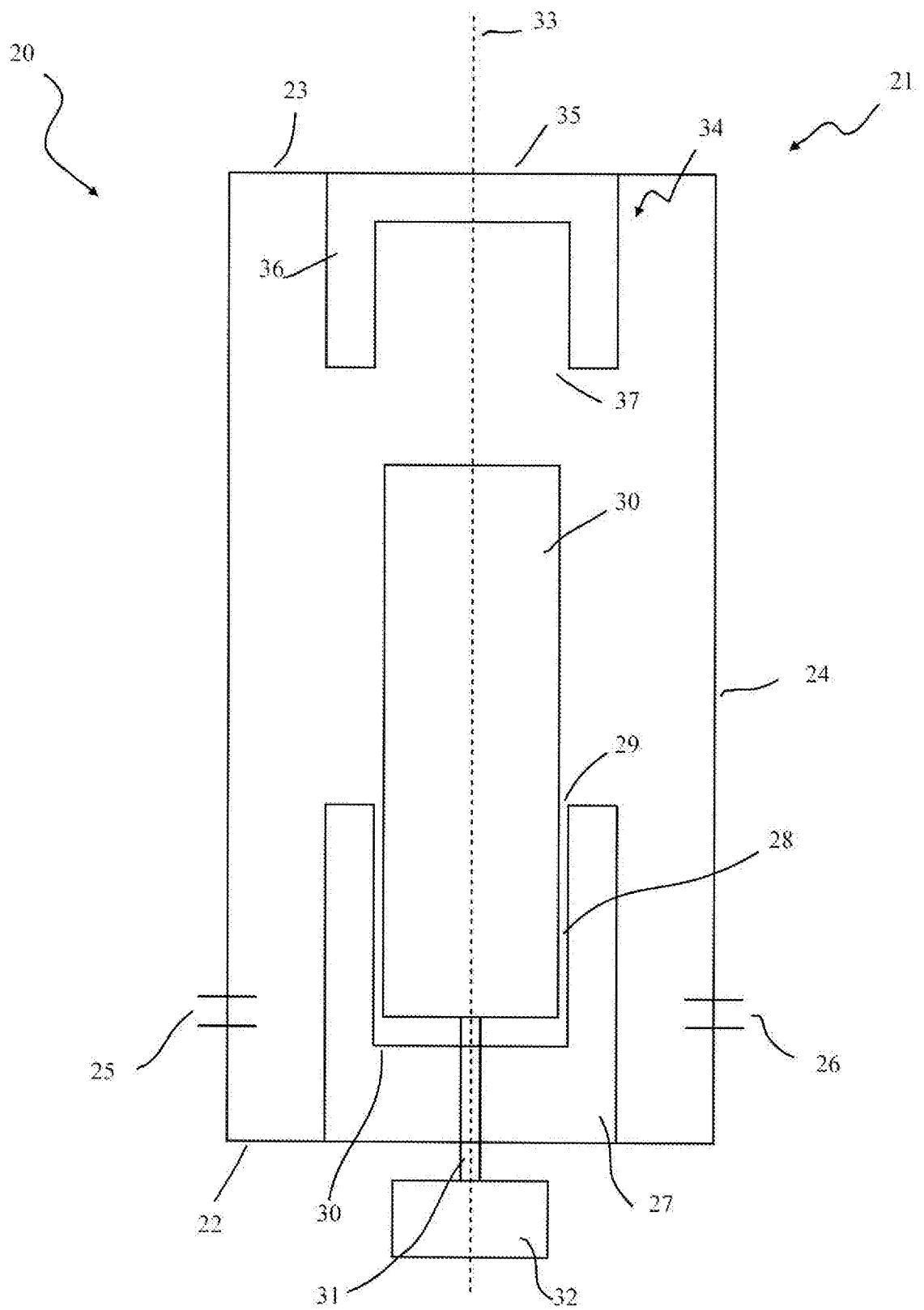

Figure 2

3/4

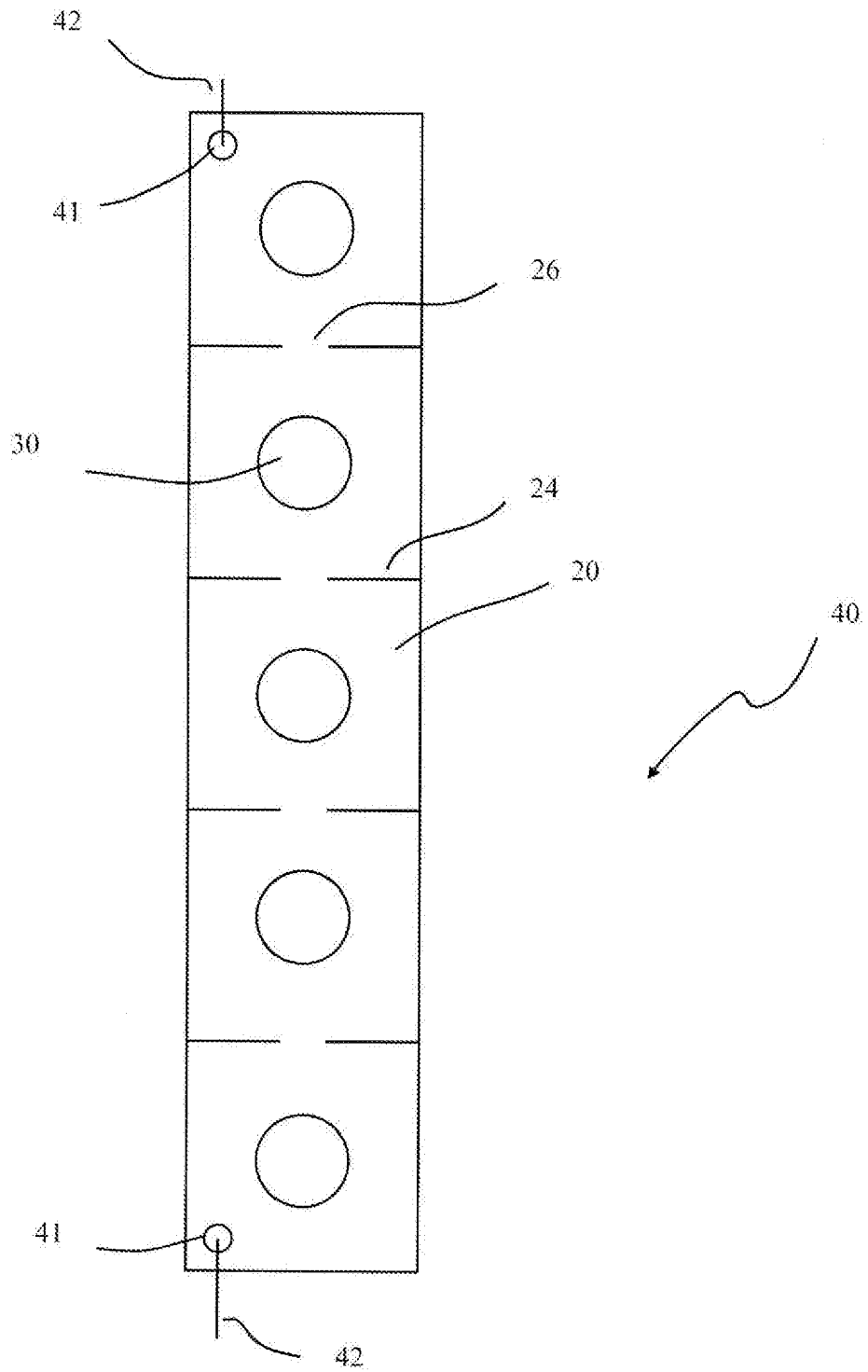

Figure 3

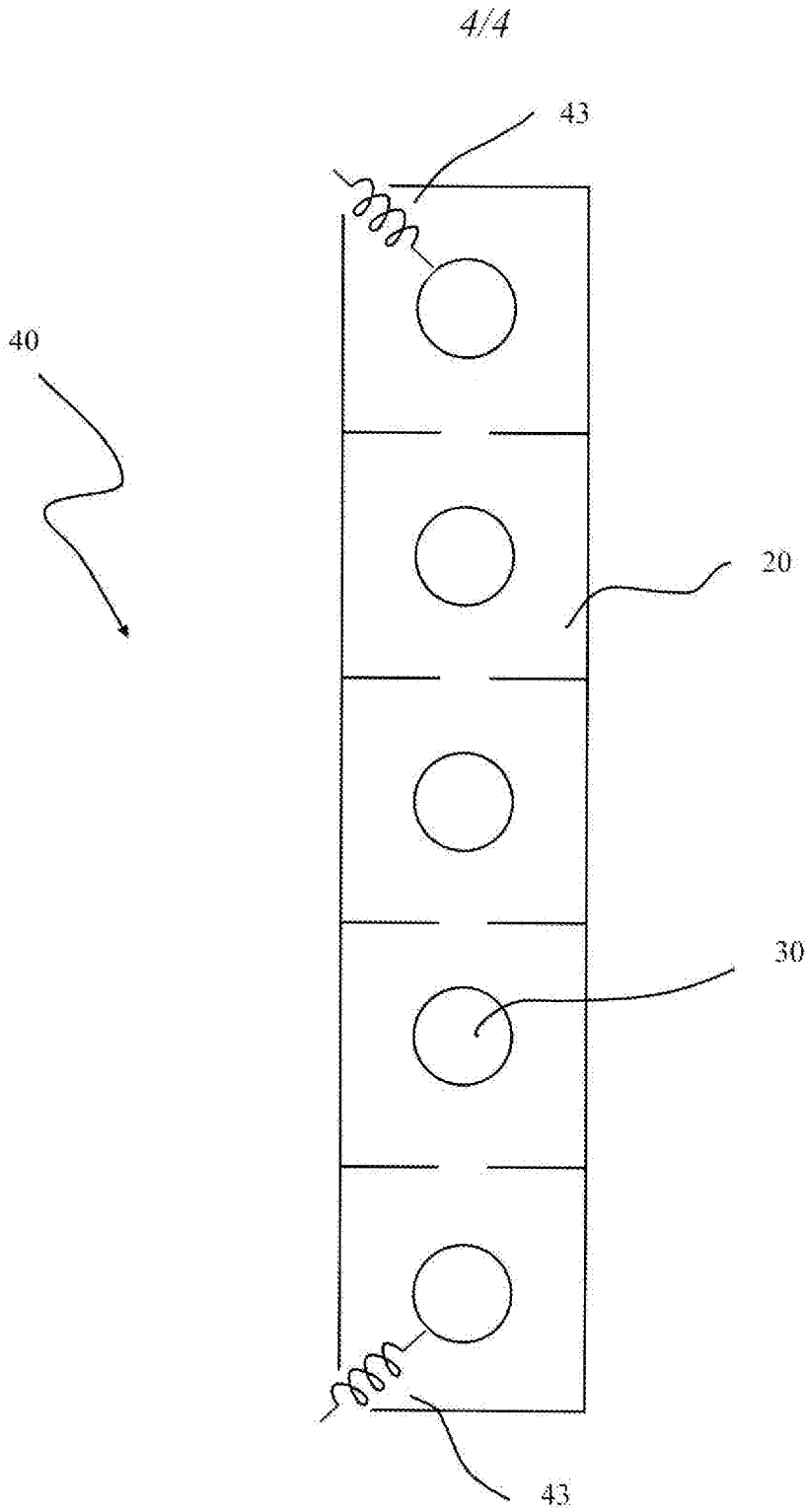

Figure 4