

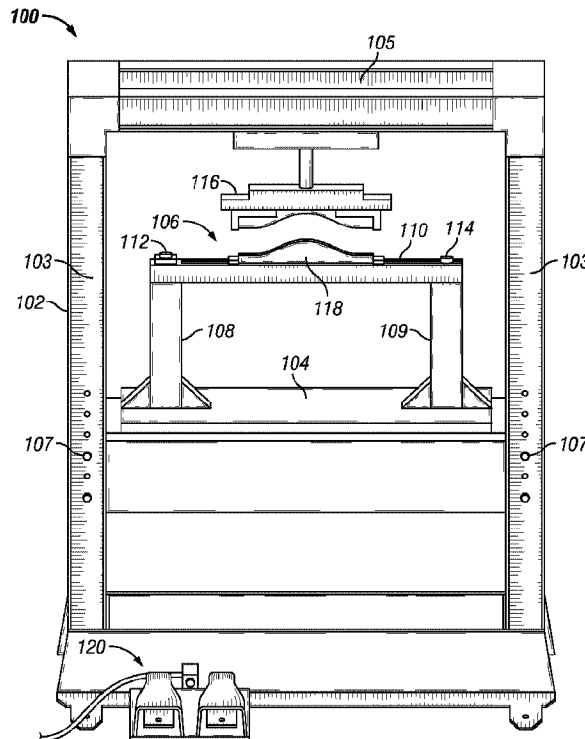

(86) Date de dépôt PCT/PCT Filing Date: 2016/04/22
 (87) Date publication PCT/PCT Publication Date: 2016/11/17
 (45) Date de délivrance/Issue Date: 2023/10/03
 (85) Entrée phase nationale/National Entry: 2017/11/07
 (86) N° demande PCT/PCT Application No.: US 2016/028879
 (87) N° publication PCT/PCT Publication No.: 2016/182713
 (30) Priorité/Priority: 2015/05/08 (US14/707,845)

(51) Cl.Int./Int.Cl. *B21D 53/00* (2006.01),
B21D 11/10 (2006.01), *E21B 17/10* (2006.01)
 (72) Inventeurs/Inventors:
MILLER, EUGENE EDWARD, US;
JOHNSTON, EVERETT H., US;
NEEL, JESSE L., US;
CARROLL, CHARLES, US;
RIBBLE, GEORGE W., US
 (73) Propriétaire/Owner:
INNOVEX DOWNHOLE SOLUTIONS, INC., US
 (74) Agent: KIRBY EADES GALE BAKER

(54) Titre : DISPOSITIFS ET PROCÉDES POUR LA FORMATION DE RESSORTS EN ARC DE CENTREURS MONOBLOCS
 (54) Title: DEVICES AND METHODS FOR FORMING BOW SPRINGS OF ONE-PIECE CENTRALIZERS



(57) Abrégé/Abstract:

A device for forming bow springs in a one-piece centralizer includes a swing arm that is configured to receive the one-piece centralizer. The device and process using the device include mechanically applying, with a press, an external load onto an un-formed bow spring positioned on a form of the swing arm. When the load is applied with the device, the un-formed centralizer is forced downward to allow the bow spring to take the desired form/shape/geometry, length, and height of a formed bow spring.

(12) INTERNATIONAL APPLICATION PUBLISHED UNDER THE PATENT COOPERATION TREATY (PCT)

(19) World Intellectual Property
Organization
International Bureau(10) International Publication Number
WO 2016/182713 A1(43) International Publication Date
17 November 2016 (17.11.2016)

(51) International Patent Classification:

B21D 11/10 (2006.01) **B21D 43/28** (2006.01)
B21D 43/11 (2006.01)

(21) International Application Number:

PCT/US2016/028879

(22) International Filing Date:

22 April 2016 (22.04.2016)

(25) Filing Language:

English

(26) Publication Language:

English

(30) Priority Data:

14/707,845 8 May 2015 (08.05.2015) US

(71) Applicant: ANTELOPE OIL TOOL & MFG. CO., LLC [US/US]; 8807 W. Sam Houston Parkway N., Ste. 200, Houston, TX 77040 (US).

(72) Inventors: MILLER, Eugene, Edward; 103 Oak Ridge Terrace, Weatherford, TX 76086 (US). JOHNSTON, Everett, H.; 300 Johnston Ln., Perrin, TX 76846 (US). NEEL, Jesse, L.; 303 Bay Hill Ct., Willow Park, TX 76008 (US). CARROLL, Charles; 4899 Fairview Rd., Millsap, TX 76066 (US). RIBBLE, George, W.; 8510 Sunset Loch Dr., Houston, TX 77379 (US).

(74) Agent: ATKINSON, Garrett, J.; MH2 Technology Law Group, 1951 Kidwell Drive, Suite 550, Tysons Corner, VA 22182 (US).

(81) Designated States (unless otherwise indicated, for every kind of national protection available): AE, AG, AL, AM, AO, AT, AU, AZ, BA, BB, BG, BH, BN, BR, BW, BY, BZ, CA, CH, CL, CN, CO, CR, CU, CZ, DE, DK, DM, DO, DZ, EC, EE, EG, ES, FI, GB, GD, GE, GH, GM, GT, HN, HR, HU, ID, IL, IN, IR, IS, JP, KE, KG, KN, KP, KR, LA, LC, LK, LR, LS, LU, LY, MA, MD, ME, MG, MK, MN, MW, MX, MY, MZ, NA, NG, NI, NO, NZ, OM, PA, PE, PG, PH, PL, PT, QA, RO, RS, RU, RW, SA, SC, SD, SE, SG, SK, SL, SM, ST, SV, SY, TH, TJ, TM, TN, TR, TT, TZ, UA, UG, US, UZ, VC, VN, ZA, ZM, ZW.

(84) Designated States (unless otherwise indicated, for every kind of regional protection available): ARIPO (BW, GH, GM, KE, LR, LS, MW, MZ, NA, RW, SD, SL, ST, SZ, TZ, UG, ZM, ZW), Eurasian (AM, AZ, BY, KG, KZ, RU, TJ, TM), European (AL, AT, BE, BG, CH, CY, CZ, DE, DK, EE, ES, FI, FR, GB, GR, HR, HU, IE, IS, IT, LT, LU, LV, MC, MK, MT, NL, NO, PL, PT, RO, RS, SE, SI, SK, SM, TR), OAPI (BF, BJ, CF, CG, CI, CM, GA, GN, GQ, GW, KM, ML, MR, NE, SN, TD, TG).

[Continued on next page]

(54) Title: DEVICES AND METHODS FOR FORMING BOW SPRINGS OF ONE-PIECE CENTRALIZERS

(57) Abstract: A device for forming bow springs in a one-piece centralizer includes a swing arm that is configured to receive the one-piece centralizer. The device and process using the device include mechanically applying, with a press, an external load onto an un-formed bow spring positioned on a form of the swing arm. When the load is applied with the device, the un-formed centralizer is forced downward to allow the bow spring to take the desired form/shape/geometry, length, and height of a formed bow spring.

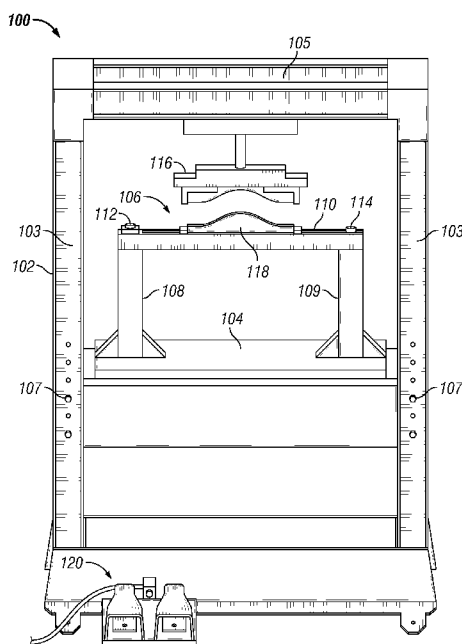

FIG. 1

WO 2016/182713 A1

WO 2016/182713 A1 

Published:

— *with international search report (Art. 21(3))*

DEVICES AND METHODS FOR FORMING BOW SPRINGS OF ONE-PIECE CENTRALIZERS

Cross-Reference to Related Applications

[0001] This application claims priority to U.S. Patent Application serial no. 14/707,845, filed on May 8, 2015.

Background

[0002] In hydrocarbon drilling operations, centralizers may be secured at spaced intervals along a tubular string. The centralizers provide a radial stand-off between the tubular and the wall of a drilled borehole in which the tubular is installed. Bow spring centralizers generally include collars defining a bore therethrough to receive the tubular, and a plurality of angularly-spaced bow springs biased to provide stand-off. Bow spring centralizers may collapse to pass, *e.g.*, along with the tubular, through restrictions, and deploy to provide a generally uniform annulus between the exterior of the tubular and the wall of the borehole. Thus, for example in cementing operations, a bow spring centralizer promotes uniform and continuous distribution of cement slurry around the tubular string for cementing the tubular within a targeted interval of the borehole. The resulting cement liner may reinforce the tubular string, isolate the tubular from corrosive formation fluids and prevent fluid flow between penetrated geologic formations.

[0003] Currently, when forming a one-piece centralizer, an odd number of bow springs are usually required to be formed. This is because forming tool is positioned between opposing bow springs and expanded, thereby expanding the bow springs outward. With this process and tool, issues arise in forming a one-piece centralizer. For example, the forming process may not have the required stroke/length to appropriately form the opposite bow and therefore would not achieve desired dimensions of the centralizer, *e.g.*, geometry, length, and height. Therefore, there is a need for devices and processes for forming bow springs in one-piece centralizers.

Summary

[0004] Embodiments of the disclosure may provide a method that includes positioning a centralizer including a plurality of bow springs on a forming device. The forming device may include a press, a movable arm, and a form coupled to movable arm. The form is configured to shape the plurality of bow springs, and a first bow spring of the plurality of bow springs is

positioned on the form. The method may also include actuating the press to apply pressure to the first bow spring between the form and the press. Additionally, the method may include repositioning the centralizer to position a second bow spring of the plurality of bow springs on the form, and actuating a press to apply pressure to the second bow spring.

[0005] Embodiments of the disclosure may also provide a device that includes a stand for receiving a centralizer having a plurality of bow springs. The stand may include a leg and an arm configured to receive the centralizer. The arm is movably coupled to leg to allow the arm to rotate about an axis of the leg. The stand may also include a form coupled to the arm, wherein the form is configured to shape the plurality of bow springs. The device may also include a press configured to apply pressure to at least one of the plurality of bow springs to shape the at least one of the plurality of bow springs on the form, and a control coupled to the press. The control is configured to actuate to the press to apply pressure to the at least one of the plurality of bow springs

[0006] Embodiments of the disclosure may further provide a method including forming a one-piece centralizer comprising a first collar, a second collar, and a plurality of bow springs, and cutting the first collar and the second collar of the one-piece centralizer along a central axis to form two separate halves of the one-piece centralizer. The method may also include forming a plurality of hinges on each of the two halves of the one-piece centralizer, and reforming the one-piece centralizer by attaching the two halves at the plurality of hinges.

Brief Description of the Drawings

[0007] Various features of the embodiments may be more fully appreciated, as the same become better understood with reference to the following detailed description of the embodiments when considered in connection with the accompanying figures, in which:

[0008] Figure 1 illustrates a perspective view of a centralizer forming machine, according to an embodiment.

[0009] Figure 2 illustrates a flowchart of a method for forming bow springs of a centralizer, according to an embodiment.

[0010] Figures 3A-3G illustrate perspective views of the centralizer forming machine forming a centralizer, according to an embodiment.

[0011] Figure 4 illustrates a perspective view of a centralizer arm, according to an embodiment.

[0012] Figure 5 illustrates a flowchart of a method for forming centralizer arms, according to an embodiment.

[0013] Figures 6A and 6B illustrate perspective views of the centralizer and the centralizer arms, according to an embodiment.

[0014] Figure 7 illustrates a flowchart of a method for forming a centralizer, according to an embodiment.

[0015] Figures 8A-8D illustrate perspective views of a centralizer, according to an embodiment.

Detailed Description

[0016] For simplicity and illustrative purposes, the principles of the present teachings are described by referring mainly to examples of various embodiments thereof. However, one of ordinary skill in the art would readily recognize that the same principles are equally applicable to, and may be implemented in, all types of information and systems, and that any such variations do not depart from the true spirit and scope of the present teachings. Moreover, in the following detailed description, references are made to the accompanying figures, which illustrate specific examples of various embodiments. Electrical, mechanical, logical and structural changes may be made to the examples of the various embodiments without departing from the spirit and scope of the present teachings. The following detailed description is, therefore, not to be taken in a limiting sense and the scope of the present teachings is defined by the appended claims and their equivalents.

[0017] Aspects of the present disclosure are directed to devices and process for forming bow springs in one-piece centralizers. The device includes a swing arm that is configured to receive the one-piece centralizer. The device and process using the device include mechanically applying, with a press, an external load onto an un-formed bow spring positioned on a form of the swing arm. When the load is applied with the device, the un-formed centralizer is forced downward to allow the bow spring to take the desired form/shape/geometry, length, and height of a formed bow spring. The forming process allows a centralizer with either an even or odd number of bows to be formed.

[0018] One example of a one-piece centralizer is a centralizer that is formed from a single tubular, e.g., by cutting, as described in U.S. Patent No. 7,845,061. Another example of a one-piece centralizer is a centralizer formed from a flat plate that is rolled and then cut to form the end collars and ribs thereof, as disclosed in U.S. Patent Publication No. 2014/0096888. Still

another example of a one-piece centralizer is formed as a flat plate, which is then cut and then rolled.

[0019] Figure 1 illustrates a perspective view of a centralizer forming machine 100, according to an embodiment. While Figure 1 illustrates various components contained in the centralizer forming machine 100, Figure 1 illustrates one example of a centralizer forming machine and additional components may be added and existing components may be removed.

[0020] As illustrated in Figure 1, the centralizer forming machine 100 includes a housing 102. In some embodiments, the housing 102 may be formed of two parallel and vertical legs 103 connected by a top cross bar 105. The top cross bar 105 may be coupled to the parallel legs 103 at the top of the parallel legs 103 to form a structure to support the components of the centralizer forming machine 100.

[0021] The centralizer forming machine 100 may include a platform 104. The platform 104 may be coupled to the parallel legs 103 to form a level platform to hold a stand 106. In some embodiments, the platform 104 may be moveably coupled to the parallel legs 103 by bolts 107. The bolts 107 may be removed to allow the platform 104 to be moved vertically upwards or downwards on the parallel legs 103.

[0022] The stand 106 may be formed of parallel and vertical legs 108 and 109. The legs 108 and 109 may support a swing arm 110. The swing arm 110 may be coupled to the leg 108 by a hinge 112. The hinge 112 may allow the swing arm 110 to swing about the axis of the leg 108. In some embodiments, the hinge 112 may include a bolt or pin coupled to the leg 108 and a circular hole in the swing arm 110 to receive the bolt or pin. The hinge 112 may allow the swing arm 110 to open perpendicular to a plane of the centralizer forming machine 100. The movement of the swing arm 110 may allow a one-piece centralizer to be positioned on the swing arm 110. The swing arm 110 may be coupled to the leg 109 by a locking pin 114. The locking pin 114 allows the swing arm 110 to be secured to the leg 109 to form a solid stand during the formation of bow springs of the one-piece centralizer.

[0023] The hinge 112 may allow the swing arm 110 to swing across a range of angles, allowing the one-piece centralizer to be placed on the swing arm 110. In some embodiments, for example, the hinge 112 may allow the swing arm 110 to rotate to a point that is approximately 90 degrees perpendicular to a plane of the centralizer forming machine 100. But in other embodiments, the hinge 112 may allow the swing arm 110 to rotate to other angles.

[0024] The centralizer forming machine 100 may also include a press 116 and a form 118. The press 116 and the form 118 are configured to shape the bow spring of the one-piece centralizer when placed on the form 118. The press 116 may be coupled to the top cross bar 105. The form 118 may be coupled to the swing arm 110. In some embodiments, to form a bow spring, the swing arm 110 may be opened (e.g., swung away from the plane of the centralizer forming machine 100 by some degree) to allow positioning of a bow spring of a one-piece centralizer on the form 118, without disassembling or otherwise breaking-down the one-piece centralizer. Thus, the one-piece centralizer may be positioned around the swing arm 110, such that the swing arm 110 extends, e.g., at least partially between the end collars of the one-piece centralizer. Once placed, the swing arm 110 may be closed and secured in place by the locking pin 114. When locked by the locking pin 114, the form 118, with the positioned bow spring, may be positioned directly below the press 116.

[0025] The press 116 may be shaped as a concave curve to form the shape of a bow spring of the one-piece centralizer. The form 118 may be configured in a convex curve that mirrors the concave curve of the press 116. Thus, the form 118 may be disposed radially within the one-piece centralizer, while the press 116 may be formed radially outside of the one-piece centralizer. The press 116, when activated, moves onto the form 118, e.g., vertically, as shown. The press 116 and the form 118 may be positioned on the centralizer forming machine 100 so that convex and concave curves mate when the press 116 moves (e.g., descends) onto the form 118. When a bow spring of the one-piece centralizer is positioned on the form 118, the press 116 compresses the bow spring against the form 118. The press 116 may apply a load on the bow spring to form the bow spring in the shape of the form 118. Once formed, the bow spring of the one-piece centralizer may have an outward bow in the shape of the form 118. The form 118 may be removed from the swing arm 110 and replaced with another form of a different size. In one embodiment, the one-piece centralizer may have different shaped bow springs by using different sized forms.

[0026] As such, the centralizer forming machine 100 may deform each bow spring in turn, without pushing against an opposing bow spring or, in this case, any adjacent bow springs. In some embodiments, however, the press 116 and/or form 118 may optionally be configured to receive two or more bow springs at a time, e.g., adjacent bow springs, so as to simultaneously expand two or three bow springs. In such case, however, the deformation of the two or more

bow springs may occur without employing an opposing part of the centralizer to take up any reaction forces.

[0027] Although illustrated as pivoting or swinging through a horizontal plane, it will be appreciated that the swing arm 110 may swing through a vertical plane, or a plane disposed at any orientation between horizontal and vertical. Moreover, the press 116 may move perpendicular to the plane in which the swing arm 110 swings, whether vertical, horizontal, or therebetween. In other embodiments, the press 116 may move in a direction that is not perpendicular to the plane in which the swing arm 110 swings. In another embodiment, the form 118 may be moved toward the press 116.

[0028] The centralizer forming machine 100 may also include a control 120. The control 120 may be configured to activate the press 116. For example, the control 120 may be configured to cause the press vertically upwards and downwards (or otherwise toward and away from the press 116) in the centralizer forming machine 100. As illustrated, for example, the control 120 may be configured as one or more foot pedals. The foot pedals may be configured to actuate the press 116 upwards and downwards, respectively, by applying pressure with the ball or heel of a foot to the foot pedals. The foot pedal is one example of a control 120. The control 120 may be any type of electronic and/or mechanical and/or hydraulic and/or pneumatic control that actuates the press 116, for example, an electrical switch, electrical button, mechanical switch, mechanical button, etc.

[0029] Figure 2 illustrates a flowchart of a method 200 for using the centralizer forming machine 100 to shape the bow springs of a one-piece centralizer, according to an embodiment. Figures 3A-3G illustrate perspective views of the centralizer forming machine 100 during operation, according to an embodiment, e.g., pursuant to the method 200. The illustrated stages of the method 200 are examples and any of the illustrated stages may be removed or combined, additional stages may be added, and the order of the illustrated stages may be changed.

[0030] Once the process begins, in 202, the locking pin may be removed and the swing arm of the stand may be opened. For example, as illustrated in Figure 3A, the swing arm 110 may be rotated outward about an axis of the leg 108. The swing arm 110 may be opened so that a one-piece centralizer may be placed on the swing arm 110.

[0031] In 204, the centralizer may be secured to the swing arm and a bow spring of the centralizer may be positioned on the form. For example, as illustrated in Figure 3B, a one-piece centralizer 302 may be placed on the swing arm 110 and a bow spring 304 may be positioned on

the form 118. The bow spring 304 may be positioned on the form 118 so that the center of the bow spring 304 aligns with the center of the form 118. In some embodiments, the one-piece centralizer 302 may be secured in place on the form 118 by the weight of the one-piece centralizer 302. In some embodiments, the one-piece centralizer 302 may be secured in place on the form 118 by a mechanical device, such as a clamp.

[0032] In 206, the swing arm may be closed and the locking pin may be secured. For example, as illustrated in Figure 3C, the swing arm 110 may be closed and the locking pin 114 may be secured. Once the swing arm 110 is closed, the form 118, supporting the bow spring 304, may be positioned directly below the press 116.

[0033] In 208, the press may be activated to form the bow spring of the one-piece centralizer. For example, as illustrated in Figure 3D, the control 120 of the centralizer forming machine 100 may be actuated. Once the control 120 is actuated, the press 116 may descend and compress the bow spring 304 on the form 118. As illustrated in Figure 3E, the load applied by the press 116 may cause the bow spring 304 to bend in the shape of the form 118. Once applied, the control 120 may again be actuated to move the press 116 upwards from the form 118. As illustrated in Figure 3F, due to the load applied to the bow spring 304 and the metallurgical properties of the bow spring 304 material, the bow spring 304 may generally maintain the shape of the form 118.

[0034] In 210, it may be determined whether additional bow springs are to be formed. If additional bow springs are to be formed, in 212, the centralizer may be rotated to position the next bow spring to be formed on the form. For example, as illustrated in Figure 3G, the centralizer 302 may be rotated to another bow spring 304 that needs to be formed. Then, stage 208 may be repeated to form the bow spring 304.

[0035] Stages 208-212 may be repeated until some or all of the bow springs 304 have been formed. If all the bow springs have been formed, in 214, the locking pin may be removed, the swing arm may be opened, and the centralizer may be removed.

[0036] In embodiments described above, any type of one-piece centralizer may be utilized with the centralizer forming machine 100 and process 200. As used herein, a one-piece centralizer may include any centralizer formed in a cylindrical shape in which bow springs are to be formed. The centralizer forming machine 100 may be reconfigured to accommodate one-piece centralizers of different shapes and sizes. For example, in some embodiments, the centralizer forming machine 100 may be reconfigured with different shape and sized versions of the press 116 and the form 118 to accommodate one-piece centralizers of different shapes and sizes. In

some embodiments, the platform 104 may be moved upwards and downwards to accommodate one-piece centralizers of different shapes and sizes.

[0037] As described above, the centralizer forming machine 100 may be configured so that the swing arm 110 rotates about a vertical axis of the leg 108. In this example, the press 116 and the form may be positioned such that the press 116 moves vertically to engage the form 118. This configuration is one example of the configuration of the components of the centralizer forming machine 100. The components may be configured in any orientation and position in the centralizer forming machine 100 that allow the swing arm 110 to move to remove a one-piece centralizer and position the bow springs such that the press 116 can engage the form 118. In some embodiments, for example, the components of the centralizer forming machine may be configured so that the swing arm 110 rotates about a horizontal axis of the leg 108. For example, the stand 106 and/or platform may be coupled vertically to one of the legs 103 of the housing 102. In this example, the press 116 and the form may be positioned such that the press 116 moves horizontally to engage the form 118.

[0038] In some embodiments, the one-piece centralizer may be formed of one or more hinged centralizer arms. Figure 4 illustrates an example of centralizer arm 400 that may be utilized to form a centralizer, according to various embodiments. While Figure 4 illustrates various components contained in the centralizer arm 400, Figure 4 illustrates one example of a centralizer arm and additional components may be added and existing components may be removed.

[0039] As illustrated in Figure 4, the centralizer arm 400 may include a pair of end collars 402. Each of the end collars may include a number of hinges 404. The pair of end collars 402 may be coupled by a bow spring 406. The hinges 404 may be formed in a circular shape with a number of spaces and fingers. To form a centralizer, two or more centralizer arms 400 may be joined at the hinges 404.

[0040] Figure 5 illustrates a flowchart of a method 500 for forming a centralizer using hinged centralizer arms, according to an embodiment. Figure 6A and 6B illustrate views of the hinged centralizer arms during various stages of the method 500, according to an embodiment. The illustrated stages of the method are examples and that any of the illustrated stages may be removed, additional stages may be added, and the order of the illustrated stages may be changed.

[0041] Once the method 500 begins, in 502, centralizer arm patterns may be formed on a sheet of material. The centralizer arm patterns may be formed on the sheet of material in order to

maximize the usage of the sheet for material. That is, the patterns may be placed on the sheet of material so that, once the centralizers arms are cut from the sheet of material, the scrap material produced is minimized.

[0042] For example, as illustrated in Figure 6A, a number of centralizer arm patterns 604 may be formed on a sheet of material 602. The centralizer arm patterns 604 are formed of an “I” shape representing the collar and bow spring of the centralizer arm. The pattern may be formed to dimensions according to the desired centralizer arm dimensions. For example, in some embodiments, as illustrated in Figure 6A, the width of the collar pattern may be between about 1 inch, 2 inches, 3 inches and about 5 inches, about 6 inches, or about 7 inches (e.g., approximately 4 inches), the width of the bow spring pattern may be between about 0.5 inches, about 0.75 inches, or about 1.00 inches and about 2.0 inches, about 2.5 inches, or about 3 inches (e.g., approximately 1.5 inches), and the length of the bow spring pattern may be between about 10 inches, about 12 inches, or about 14 inches and about 18 inches, about 20 inches, or about 22 inches (e.g., approximately 16 inches).

[0043] As illustrated, to maximize the usage of the sheet of material 602, the “I” shape patterns may be interlocked and arranged in different alignments so that the usage of the sheet of material 602 is maximized. The placement of the “I” shape patterns may be selected so that the amount of scrap produced is minimized. In some embodiments, a different sized centralizer arm pattern 606 may be formed in the sheet of material 602. By using different sized centralizer arm pattern 606, the usage of the sheet of material 602 may be maximized. In some embodiments, the centralizer arm patterns 604 may also include hinge finger patterns 607.

[0044] While Figure 6A illustrates one configuration of the centralizer arm patterns, this configuration is but one example. The centralizer arm patterns may be formed on the sheet of material 602 in any configuration that maximizes the usage of the sheet of material 602, *i.e.* optimized so that the least amount of scrap is produced.

[0045] In some embodiments, for example, the sheet of material 602 may be a metal or metal alloy, for example, steel, aluminum, heat treatable steel, *etc.* The sheet of material 602 may be formed to a thickness of the desired thickness of the centralizer arm. In some embodiments, the sheet of material 602 may be of a thickness that allows hinges to be formed in the collars of the centralizer arms and allows the bow springs to be formed. For example, the sheet of material 602 may have a thickness of between about 1/32 inch, about 1/16 inch, or about 1/10 inch and about 1/6 inch, about 1/5 inch, or about 1/4 inch thick (e.g., approximately 1/8 inch thick).

[0046] In 504, the centralizer arms may be cut from the sheet of material. In 506, hinge fingers may be cut into the centralizer arms. For example, in some embodiments, the centralizer arms may be cut from the centralizer arm patterns 604 and 606 using a laser. Likewise, for example, the centralizer arms may be cut from the centralizer arm patterns 604 and 606 using a punch press or a water-jet cutter. In some embodiments, the centralizer arm patterns 604 and 606 may include the finger patterns 607 and the hinge fingers may be cut as the centralizer arms are cut. In some embodiments, the hinge fingers may be cut after the centralizer arms are cut from the sheet of material 602.

[0047] For example, Figure 6B shows an example of a centralizer arm 608 cut from the sheet of material 602. As illustrated, the centralizer arm 608 may include a pair of collars 610 which include hinge fingers 612. The pair of collars 610 may be connected by a bow spring 614. When cut from the sheet of material 602, the centralizer arm 608 may have an approximately flat profile.

[0048] In 508, a hinge may be formed in the centralizer arm from the hinge fingers. In some embodiments, for example, the hinges may be formed by rolling the hinge fingers 612 of the collars 610 to form hinges.

[0049] In 510, a centralizer may be formed from the centralizer arms. For example, two or more the centralizer arms 608 may be joined to form a one-piece centralizer. The two or more centralizer arms 608 may be joined by welding, bolts, pins, and combinations thereof.

[0050] In 512, bow springs may be formed in the centralizer arms of the constructed centralizer. In some embodiments, the bow springs may be formed utilizing the centralizer forming device 100 and process 200 described above. Once the centralizer is formed, the centralizer may be heat treated.

[0051] In some embodiments, in an alternative to stages 510 and 512, the centralizer and bow springs may be formed by another heating and forming process. For example, the centralizer arm 608 may be placed in a heating furnace. Once heated, the centralizer arm 608 may be placed in a press with dies conforming to the desired shape. After formation, the heated centralizer arm may be quenched and tempered. In some embodiments, the centralizer arm 608 may include two or more bow springs 614.

[0052] In some embodiments, hinged centralizer arms may be formed from a solid, one-piece centralizer. Figure 7 illustrates a flowchart of a method 700 for forming a centralizer having hinged centralizer arms formed from a solid, one-piece centralizer, according to an embodiment.

Figures 8A-8D illustrate views of the centralizer arms during various stages of the method 700, according to an embodiment. The illustrated stages of the method 700 are examples and that any of the illustrated stages may be removed, additional stages may be added, and the order of the illustrated stages may be changed.

[0053] Once the method 700 begins, in 702, a one-piece centralizer may be formed. The one-piece centralizer may be formed of a solid body that includes two collars coupled by a number of bow springs. The one-piece centralizer may be formed using any processes and devices to form a one-piece centralizer.

[0054] For example, as illustrated in Figure 8A, a one-piece centralizer 800 may include an upper collar 802 and a lower collar 804. The upper collar 802 and the lower collar 804 may be coupled to a number of bow springs 806.

[0055] In 704, the one-piece centralizer may be cut into two or more parts, for example, as shown, two halves. The one-piece centralizer may be cut into approximately equal halves by cutting the one-piece centralizer at the upper and lower collars along a central axis of the one-piece centralizer. The one-piece centralizer may be cut using any type of processes or devices, for example, a laser, a saw, water-jet, a cutting torch, etc.

[0056] For example, as illustrated in Figure 8A, the one-piece centralizer 800 may be cut into two approximately equal centralizer halves along a plane intersecting a central axis 808 of the one-piece centralizer 800. The one-piece centralizer 800 may be cut at the upper collar 802 and the lower collar 804 to form the approximately equal centralizer halves. As illustrated in Figure 8B, once cut, the one-piece centralizer 800 may include a centralizer half 810 and a centralizer half 812. The centralizer half 810 may include an upper collar half 814 and a lower collar half 816. The upper collar half 814 and the lower collar half 816 may be coupled, e.g., integrally, to a portion of the bow springs 806. The centralizer half 812 may include an upper collar half 818 and a lower collar half 820. The upper collar half 818 and the lower collar half 820 can be coupled to a portion of the bow springs 806.

[0057] In 706, hinges may be formed on each of the two halves of the centralizer. The hinges may include eight hinges formed on each half of centralizer. The hinges may be formed on the collars of each half at the locations the collars were cut. The hinges may be formed using any conventional processes or devices. In some embodiments, the hinges may be formed separately and connected to the collars, e.g., welded, either on the exterior of the centralizer, on the interior of the centralizer, in the space created by cutting the centralizer in half, or any combination

thereof. In some embodiments, the hinges may be formed from the material of the centralizer. For example, the hinges may be cut from the material of the centralizer.

[0058] For example, as illustrated Figure 8C, for the centralizer half 810, two hinges 822 may be formed on the upper collar half 814 and two hinges 824 may be formed on the lower collar half 816. For the centralizer half 812, two hinges 826 may be formed on the upper collar half 818 and two hinges 828 may be formed on the lower collar half 820. The two hinges 822 may be constructed so as to mate with the two hinges 826, thereby reforming the upper collar 802 when coupled together. Likewise, two hinges 824 may be constructed so as to mate with the two hinges 828, thereby reforming the lower collar 804 when coupled together.

[0059] In 708, the centralizer may be constructed from the two halves. The hinges of each half of the centralizer may be joined to reform the centralizer into one piece. The hinges may be joined using any process or device. For example, the hinges may be joined by a pin or other connector. The hinges allow the centralizer half 810 to rotate (or move) relative to the centralizer half 812. The movement of the centralizer halves 810, 812 allows the centralizer 800 to be placed around a tubular without sliding the centralizer onto the tubular from the end of the tubular. In some embodiments, the hinges may be welded together after being positioned on a tubular.

[0060] Figure 8D illustrates the reformed centralizer 800. As illustrated, the upper collar 802 may be reformed by the joint 830 formed by the coupled hinges. Likewise, the lower collar 804 may be reformed by the joint 832 formed by the coupled hinges.

[0061] In the method 700 described above, the bow springs, for example, bow springs 806, may be shaped utilizing the processes and devices described above in Figures 1, 2, and 3A-3G. In some embodiments, the bow springs may be shaped prior to cutting and reforming the centralizer, e.g., prior to stage 702. In some embodiments, the bow springs may be shaped after cutting and reforming the centralizer, e.g., after stage 708. In other embodiments, the bow springs may be shaped, e.g., expanded, at any other time during the method 700.

[0062] While the teachings have been described with reference to examples of the embodiments thereof, those skilled in the art will be able to make various modifications to the described embodiments without departing from the true spirit and scope. The terms and descriptions used herein are set forth by way of illustration only and are not meant as limitations. In particular, although the method has been described by examples, the steps of the method may be performed in a different order than illustrated or simultaneously. Furthermore, to the extent that the terms “including”, “includes”, “having”, “has”, “with”, or variants thereof are used in either the

detailed description and the claims, such terms are intended to be inclusive in a manner similar to the term “comprising.” As used herein, the terms “one or more of” and “at least one of” with respect to a listing of items such as, for example, A and B, means A alone, B alone, or A and B. Further, unless specified otherwise, the term “set” should be interpreted as “one or more.”

[0063] Also, the term "couple" or "couples" is intended to mean either an indirect or direct connection. Thus, if a first device couples to a second device, that connection may be through a direct connection, or through an indirect connection via other devices, components, and connections. In addition, as used herein, the terms "axial" and "axially" generally mean along or parallel to a central axis (e.g., central axis of a body or a port), while the terms "radial" and "radially" generally mean perpendicular to the central axis. For instance, an axial distance refers to a distance measured along or parallel to the central axis, and a radial distance means a distance measured perpendicular to the central axis. Those skilled in the art will recognize that these and other variations are possible within the spirit and scope as defined in the following claims and their equivalents.

CLAIMS

1. A method, comprising:

positioning a substantially cylindrical centralizer comprising a plurality of bow springs on a forming device, the forming device comprising a press, a movable arm, and a form coupled to the movable arm, wherein the form and the press are configured to shape the plurality of bow springs, and wherein a first bow spring of the plurality of bow springs is positioned on the form;

actuating the press to apply pressure to the first bow spring between the form and the press, thereby forming the first bow spring into a shape, wherein the shape of the first bow spring, after being formed, comprises a curved bow that is curved radially outward such that a distance between a central longitudinal axis of the centralizer and the curved bow increases proceeding from a first axial end of the centralizer toward a middle portion of the centralizer and decreases from the middle portion of the centralizer toward a second axial end of the centralizer;

rotationally moving the centralizer to position a second bow spring of the plurality of bow springs on the form;

actuating the press to apply pressure to the second bow spring positioned on the form, between the form and the press, thereby shaping the second bow spring into a curved bow similar to that achieved with respect to the first bow spring; and

repeating the rotating and press actuating steps for each subsequent bow spring until all of the bow springs on the centralizer are shaped into respective, curved bows similar to that achieved with respect to the first and second bow springs.

2. The method of claim 1, wherein positioning the centralizer comprises:

moving the movable arm about an axis of the forming device, wherein moving the movable arm allows the centralizer to be positioned on the form.

3. The method of claim 2, wherein:

moving the movable arm comprises pivoting the movable arm, such that the form is moved away from the press;

positioning the centralizer comprises receiving the centralizer around the form while the form is moved away from the press and while the centralizer is substantially cylindrical; and

the method further comprises pivoting the movable arm again, such that the form is aligned with the press, prior to actuating the press.

4. The method of claim 1, wherein actuating the press comprises moving the form, the press, or both radially, with respect to the centralizer, toward the other, so as to expand the first bow spring, without deforming the second bow spring, such that the second bow spring remains substantially straight.

5. The method of claim 1, wherein the centralizer is a one-piece centralizer.

6. The method of claim 1, wherein the centralizer is positioned around at least a portion of the movable arm and the form, such that the form is entirely within the centralizer.

7. The method of claim 1, wherein the press defines a concave arc and the form defines a convex arc, wherein the first bow spring is bent radially outward between the concave arc and the convex arc, such that at least a portion thereof forms an arc that complements the concave arc and the convex arc.

8. The method of claim 1, wherein the first bow spring maintains the shape of the form due to a radially-inward force applied to the first bow spring and metallurgical properties of the first bow spring.

9. The method of claim 1, wherein an axial slot is formed in the centralizer circumferentially-between each adjacent pair of bow springs.

10. The method of claim 1, the method further comprising:

forming a plurality of centralizer arm patterns on a sheet of material, at least one of the centralizer arm patterns comprising a plurality of hinge finger patterns, wherein the plurality of centralizer arm patterns are formed on the sheet of material to maximize usage of the sheet of material;

cutting the at least one of the centralizer arm patterns from the sheet of material to form a centralizer arm that comprises a plurality of hinge fingers; and
forming, from the plurality of hinge fingers, at least one hinge on the centralizer arm.

11. The method of claim 10, wherein the at least one of the centralizer arm patterns further comprises a bow spring pattern and a collar pattern, and wherein the plurality of hinge finger patterns are formed in the collar pattern.

12. The method of claim 10, the method further comprising:
forming the centralizer from the centralizer arm and at least one additional centralizer arm, wherein the at least one hinge of the centralizer arm is coupled to the at least one additional centralizer arm.

13. The method of claim 10, wherein the forming the at least one hinge comprises rolling the plurality of hinge fingers to form the at least one hinge.

14. The method of claim 10, wherein the plurality of centralizer arm patterns comprise different-sized centralizer arm patterns.

15. The method of claim 1, the method further comprising:
cutting the centralizer along the central longitudinal axis to form two halves of the centralizer;
forming a plurality of hinges on each of the two halves of the centralizer; and
reforming the centralizer by attaching the two halves at the hinges.

16. A device, comprising:
a stand for receiving a substantially cylindrical centralizer comprising a plurality of bow springs, the stand comprising:
a leg,
an arm configured to receive the centralizer, wherein the arm is movably coupled to leg to allow the arm to rotate about an axis of the leg, and

a form coupled to the arm;

a press configured to apply pressure to at least one of the plurality of bow springs, wherein the form and the press are configured to shape the at least one of the plurality of bow springs, wherein the shape of the at least one of the plurality of bow springs comprises a curved bow that is curved radially outward such that a distance between a central longitudinal axis of the centralizer and the curved bow increases proceeding from a first axial end of the centralizer toward a middle portion of the centralizer and decreases from the middle portion of the centralizer toward a second axial end of the centralizer; and

a control coupled to the press, wherein the control is configured to actuate to the press to apply pressure to the at least one of the plurality of bow springs.

17. The device of claim 16, wherein the stand further comprises:
an additional leg; and
a locking pin, wherein the locking pin is configured to lock the arm to the additional leg.
18. The device of claim 16, wherein the arm is configured to receive a centralizer that is one piece.
19. The device of claim 16, the device further comprising:
a platform for supporting the stand, wherein the platform is configured to be moved vertically.
20. The device of claim 16, wherein the form comprises a convex shape and the press comprises a concave shape, wherein the press, the form, or both are moved toward one another to expand the at least one of the plurality of bow springs.
21. The device of claim 16, wherein the arm rotates about a vertical axis of the leg.
22. The device of claim 16, wherein the form is removably coupled to the arm.

23. A method, comprising:

positioning a substantially cylindrical centralizer comprising a plurality of bow springs that are circumferentially-offset from one another on a forming device, the forming device comprising a press, a movable arm, and a form coupled to the movable arm, wherein the form and the press are configured to shape the plurality of bow springs, and wherein a first bow spring of the plurality of bow springs is positioned on the form;

actuating the press such that the press applies a radially-inward force on the first bow spring, such that the first bow spring is pressed between the form and the press, wherein the first bow spring is formed into a shape that corresponds to a shape of the press and a shape of the form, wherein the first bow spring extends between two collars of the centralizer, and wherein the first bow spring, after being formed, extends radially-outward farther than the two collars;

rotating the centralizer to position a second bow spring of the plurality of bow springs on the form;

actuating the press to apply pressure to the second bow spring positioned on the form, between the form and the press, thereby shaping the second bow spring into a curved bow similar to that achieved with respect to the first bow spring; and

repeating the rotating and press actuating steps for each subsequent bow spring until all of the bow springs on the centralizer are shaped into respective, curved bows similar to that achieved with respect to the first and second bow springs.

1/15

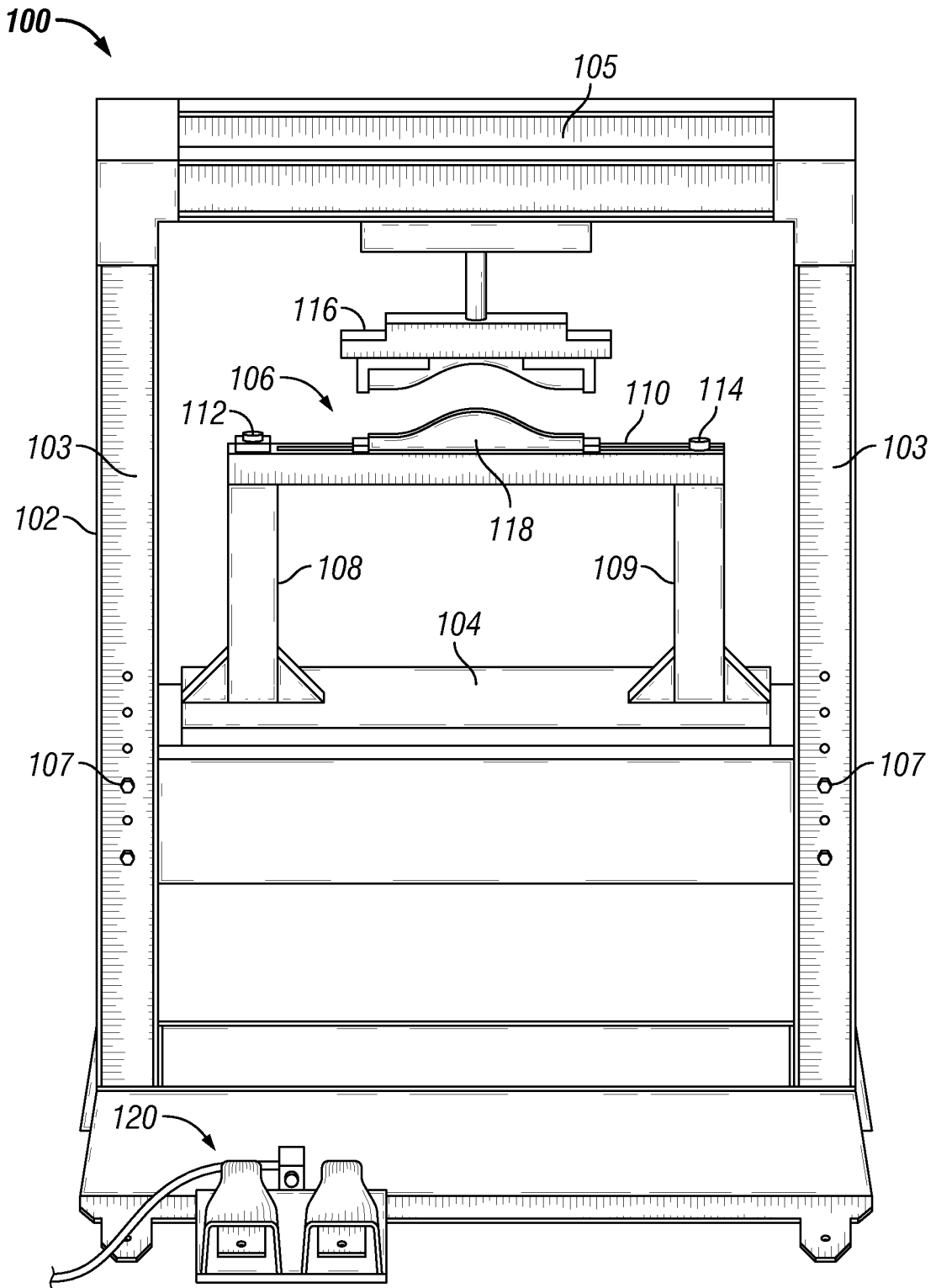

FIG. 1

2/15

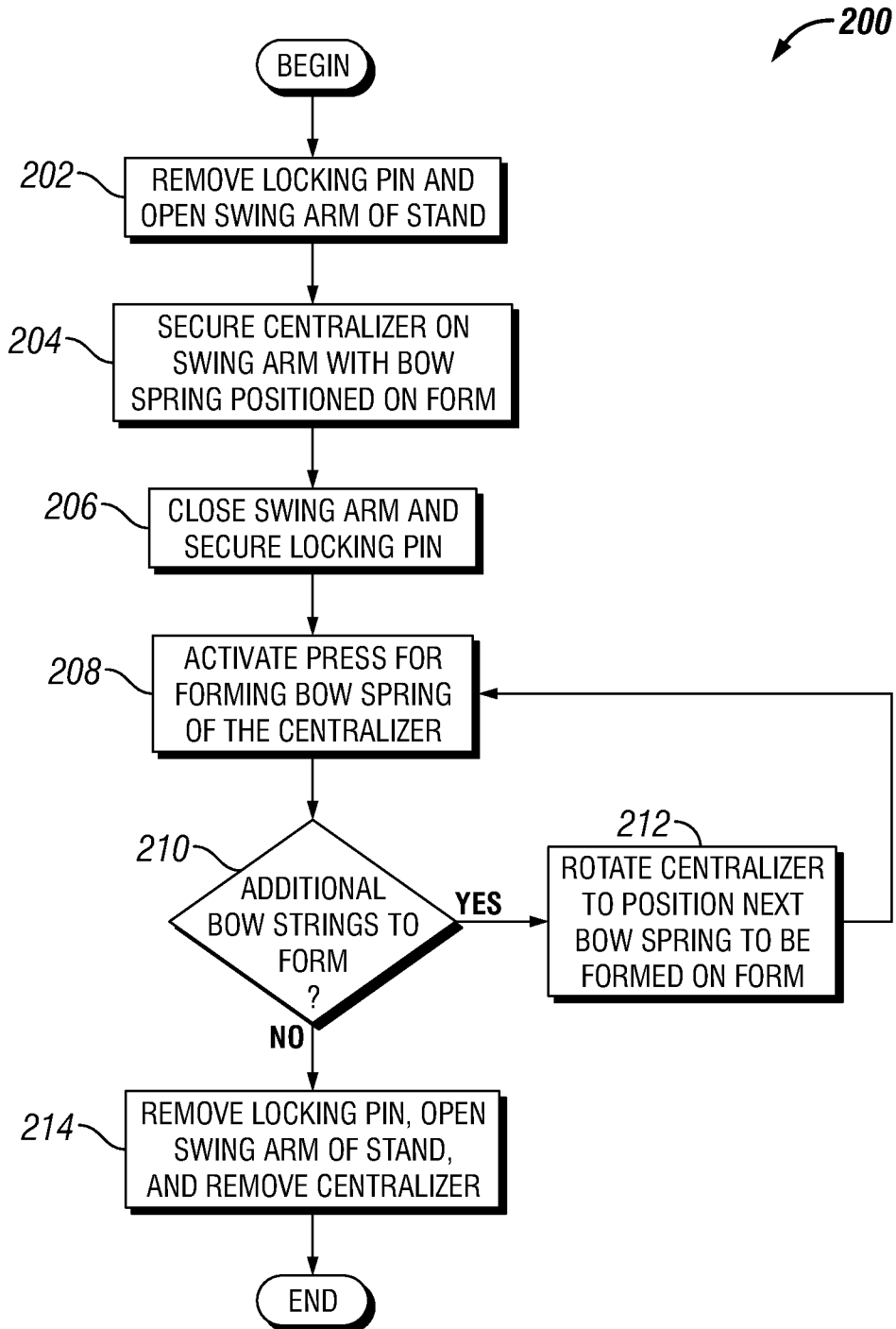

FIG. 2

3/15

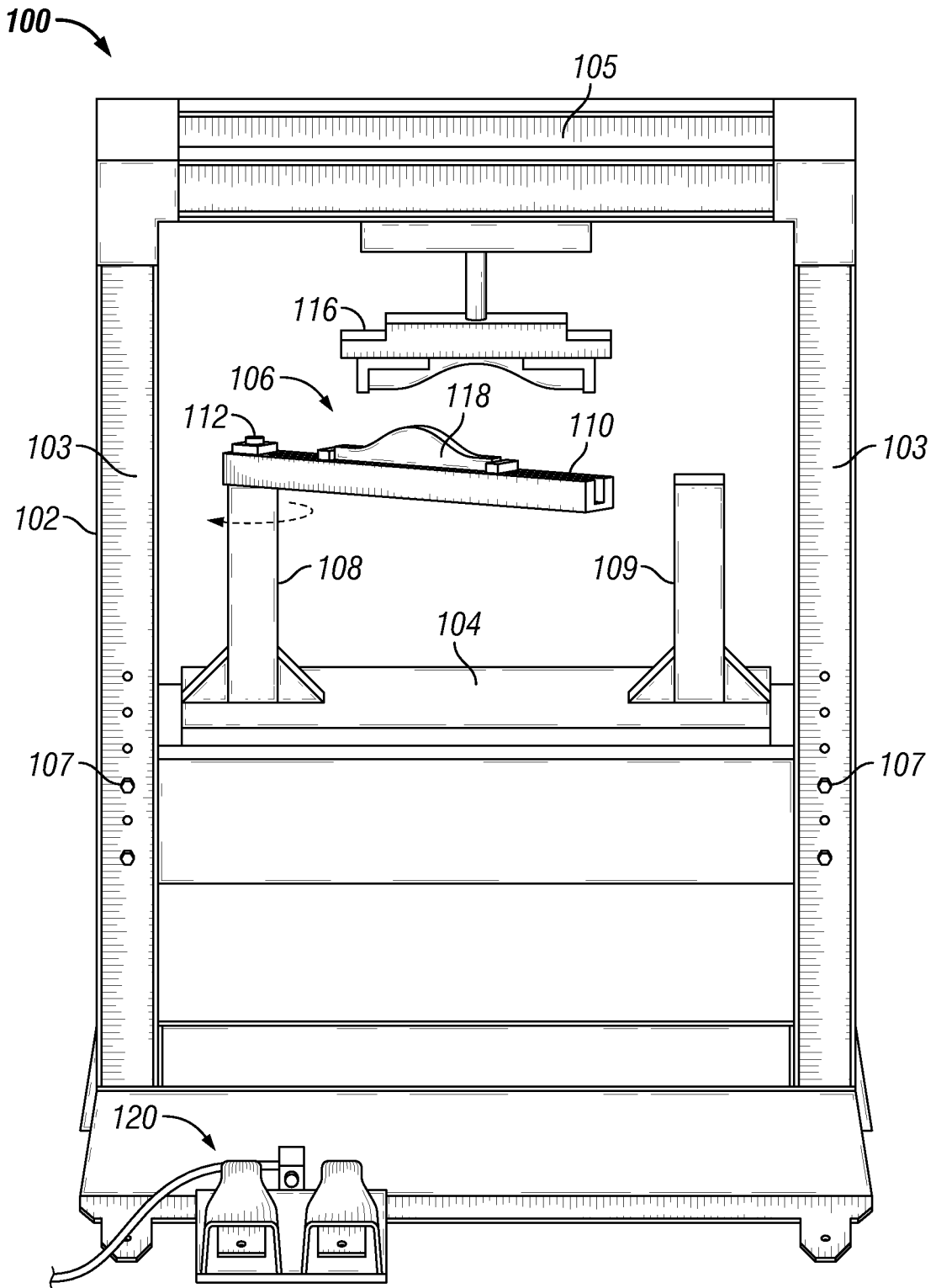

FIG. 3A

4/15

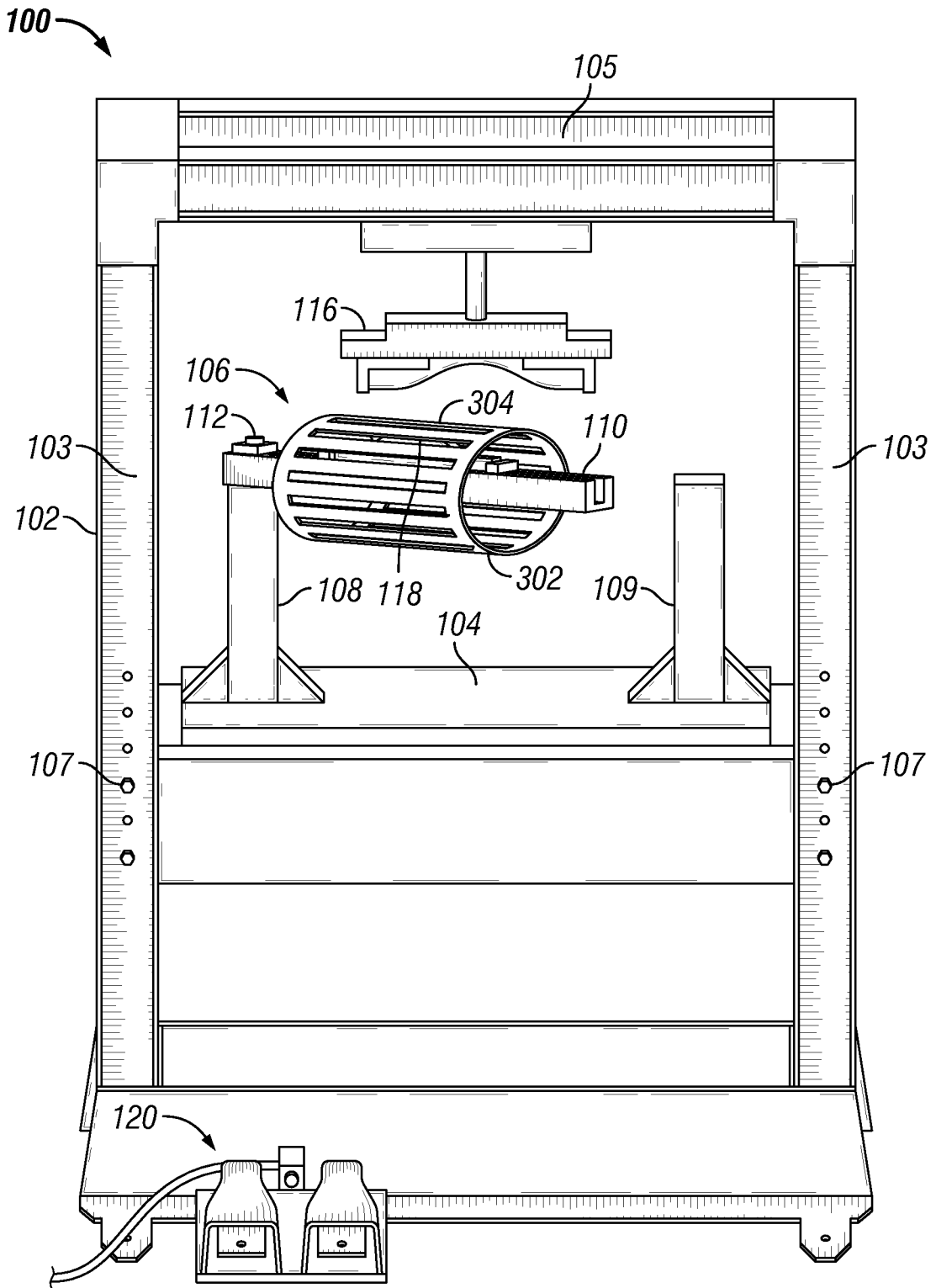

FIG. 3B

5/15

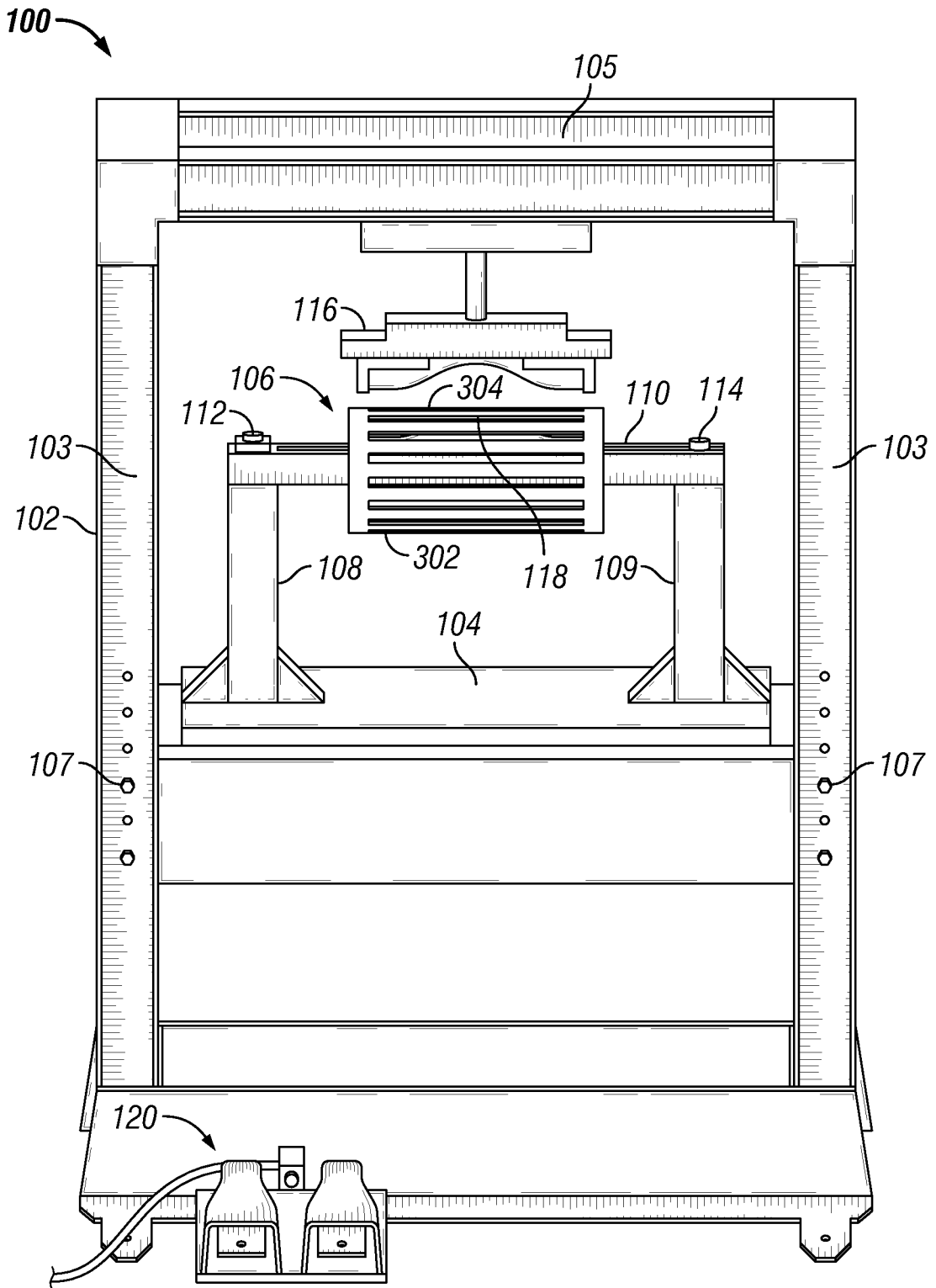

FIG. 3C

6/15

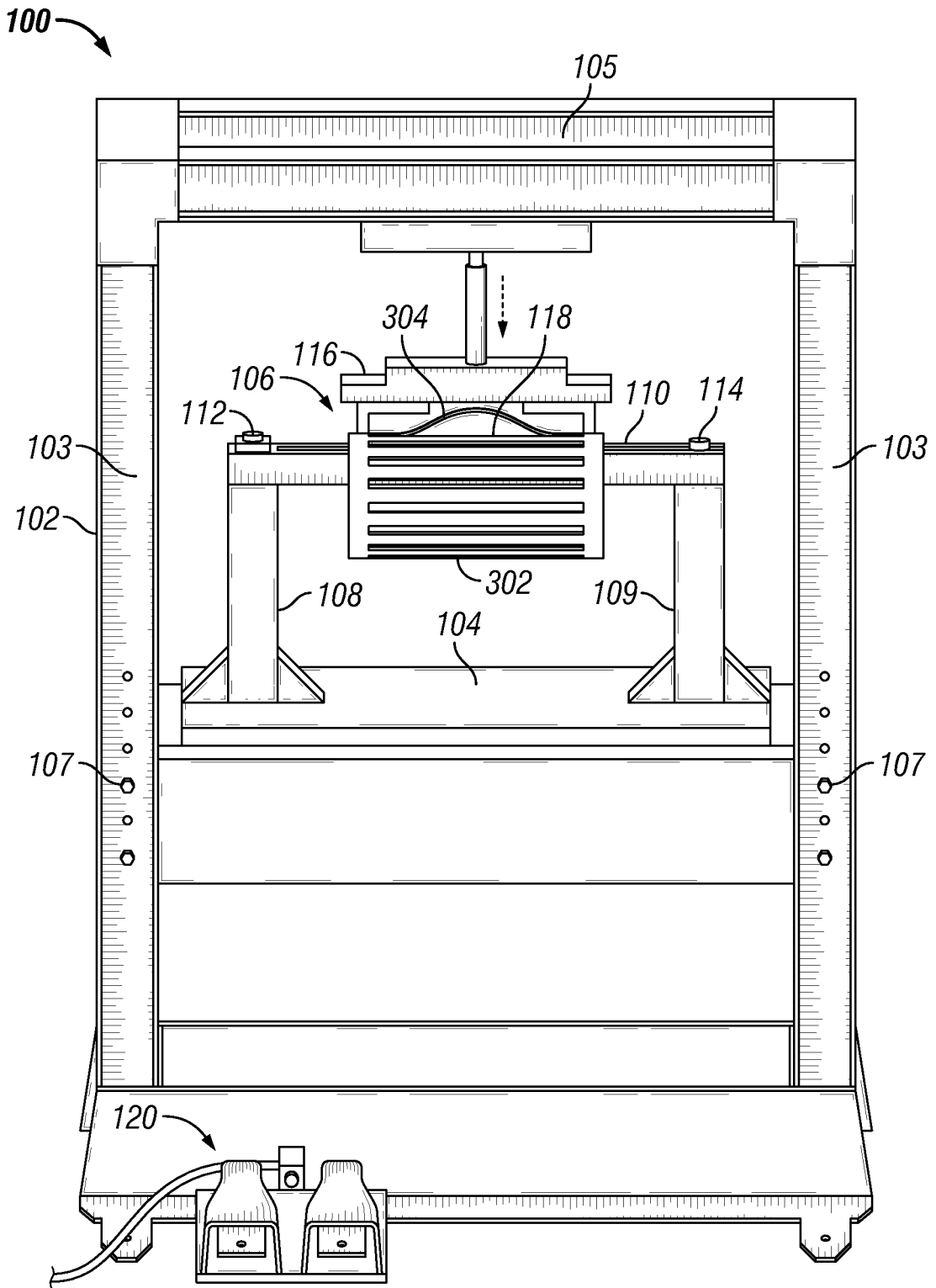

FIG. 3D

7/15

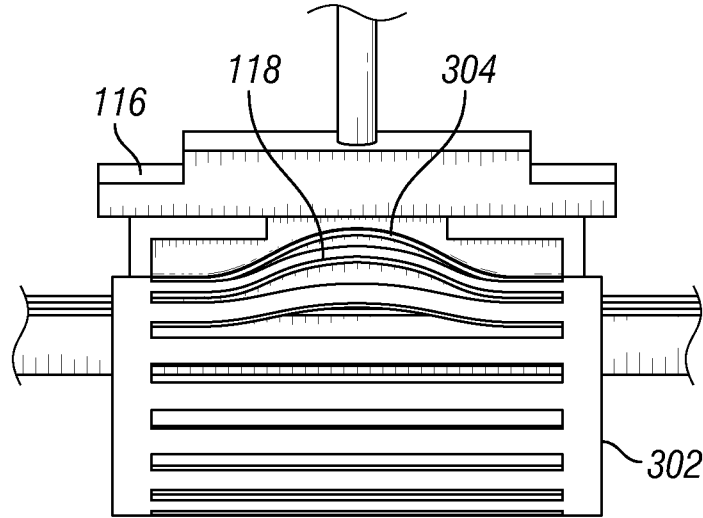

FIG. 3E

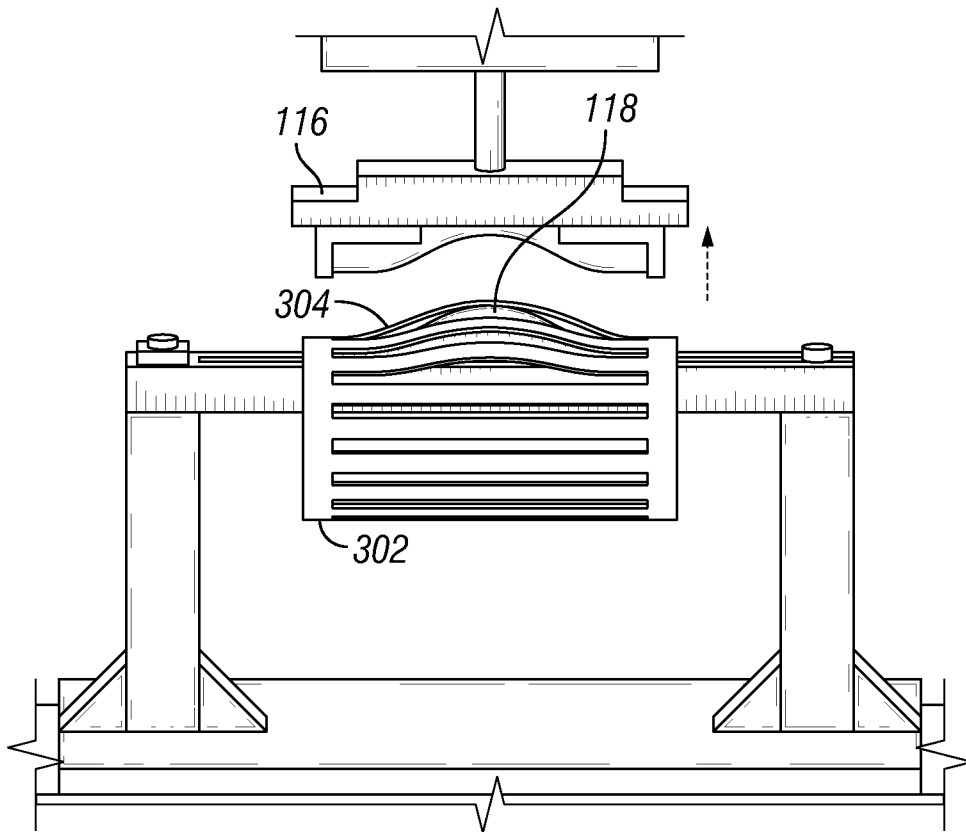

FIG. 3F

8/15

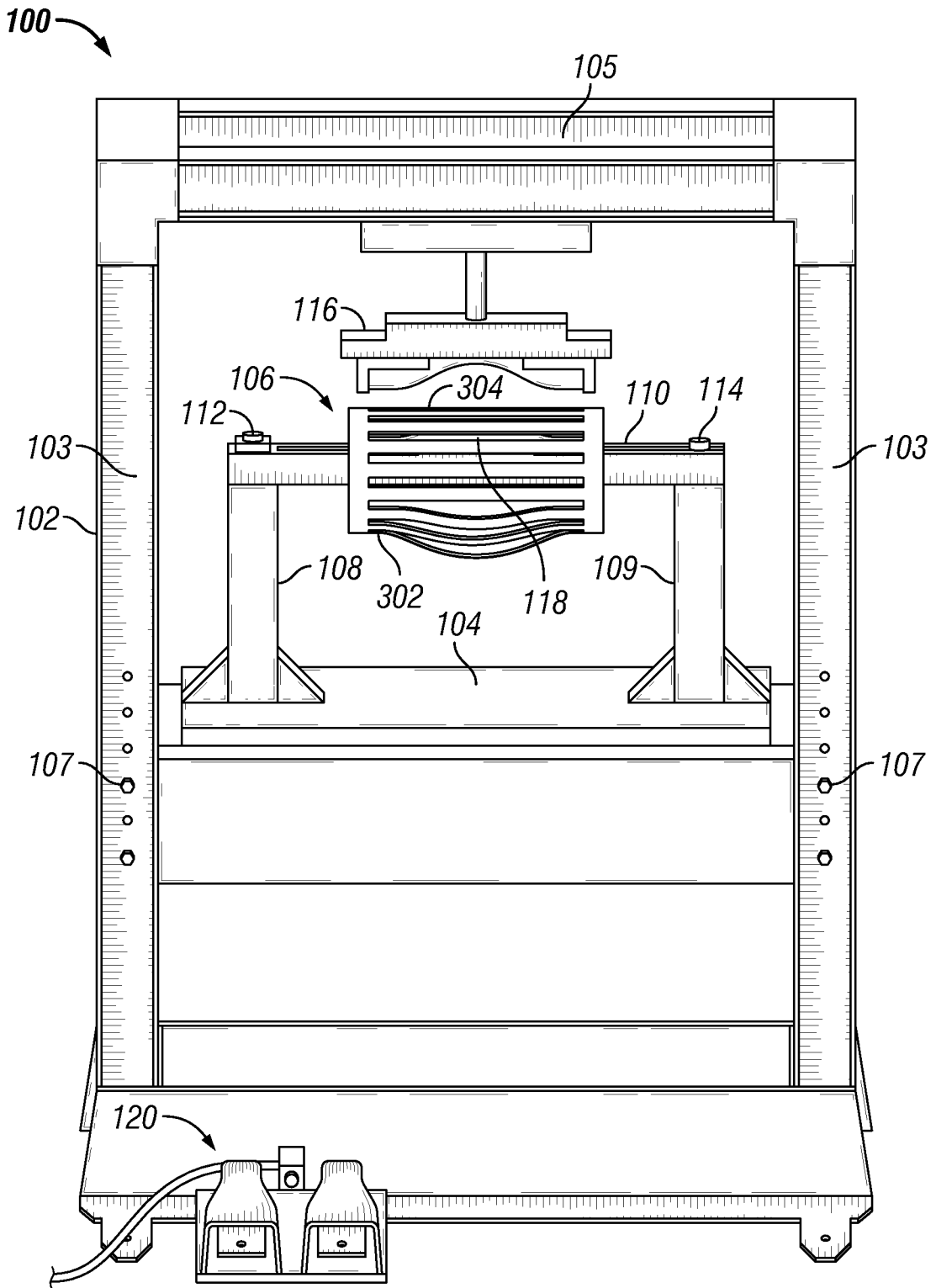

FIG. 3G

9/15

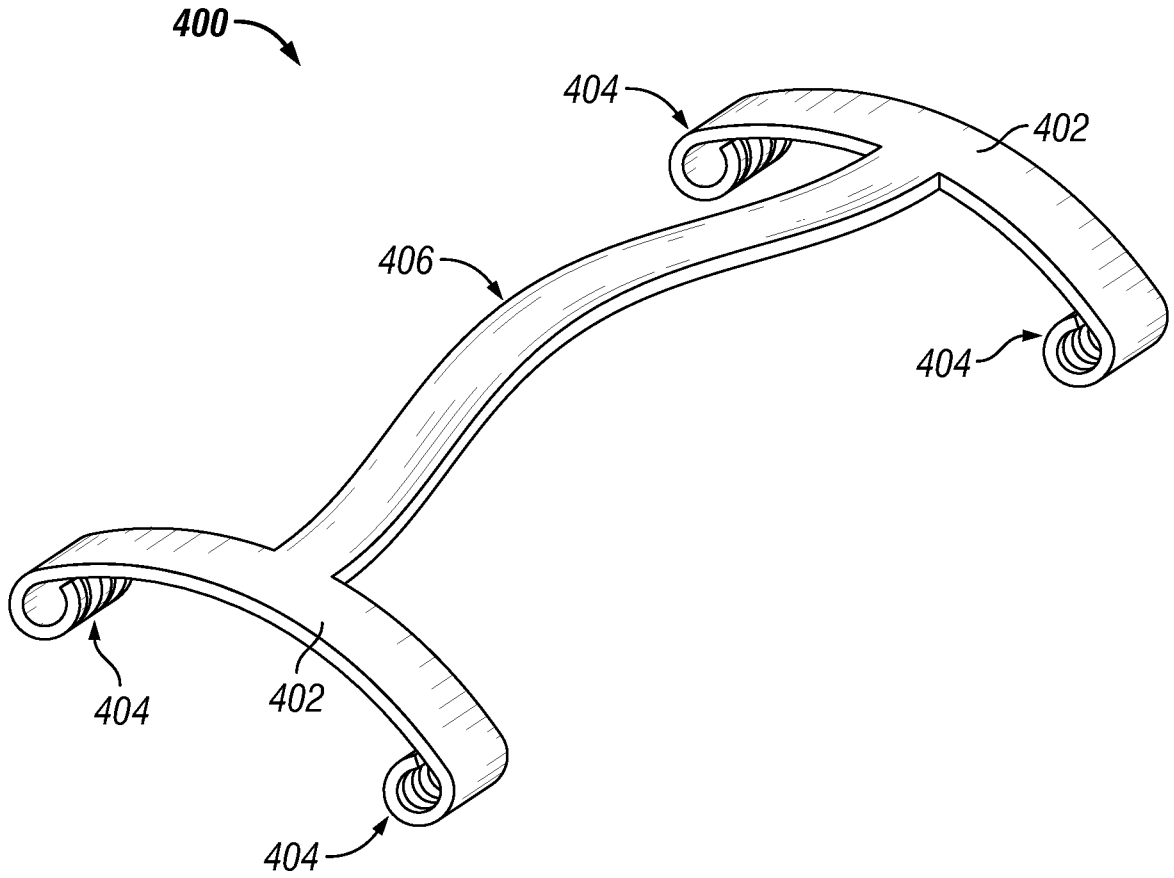
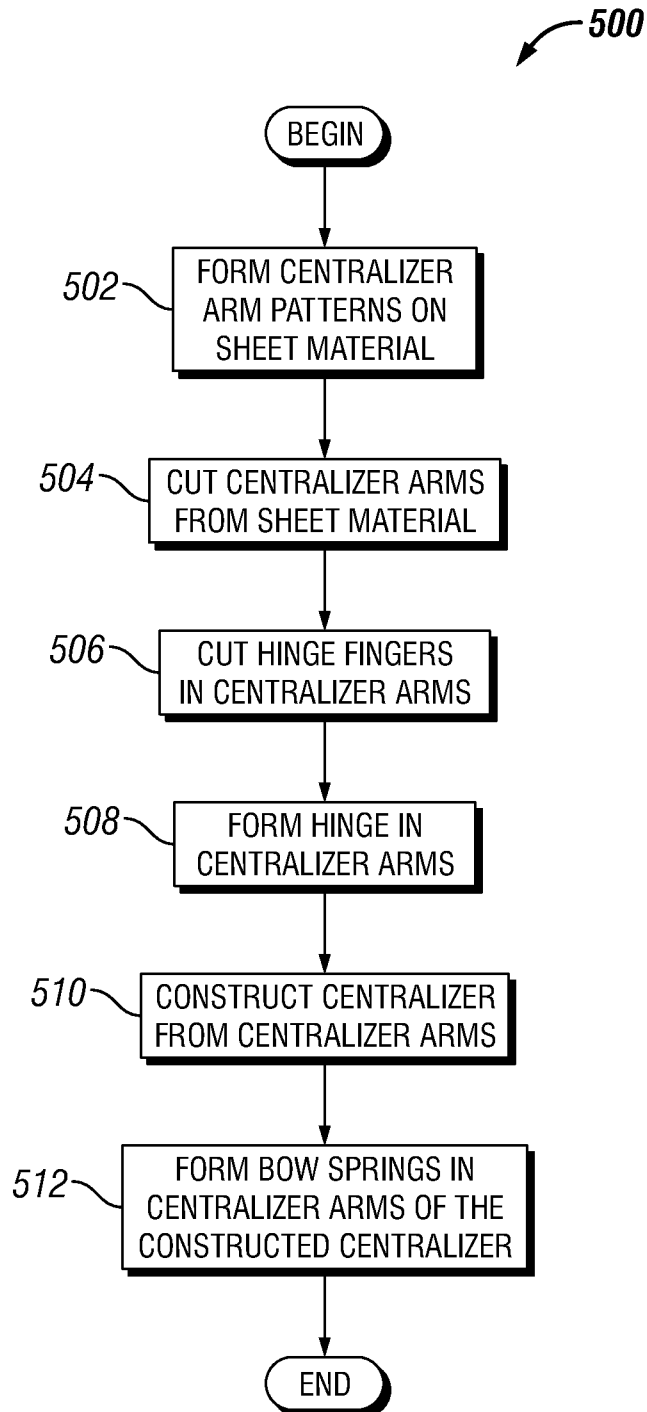

FIG. 4

10/15**FIG. 5**

11/15

602

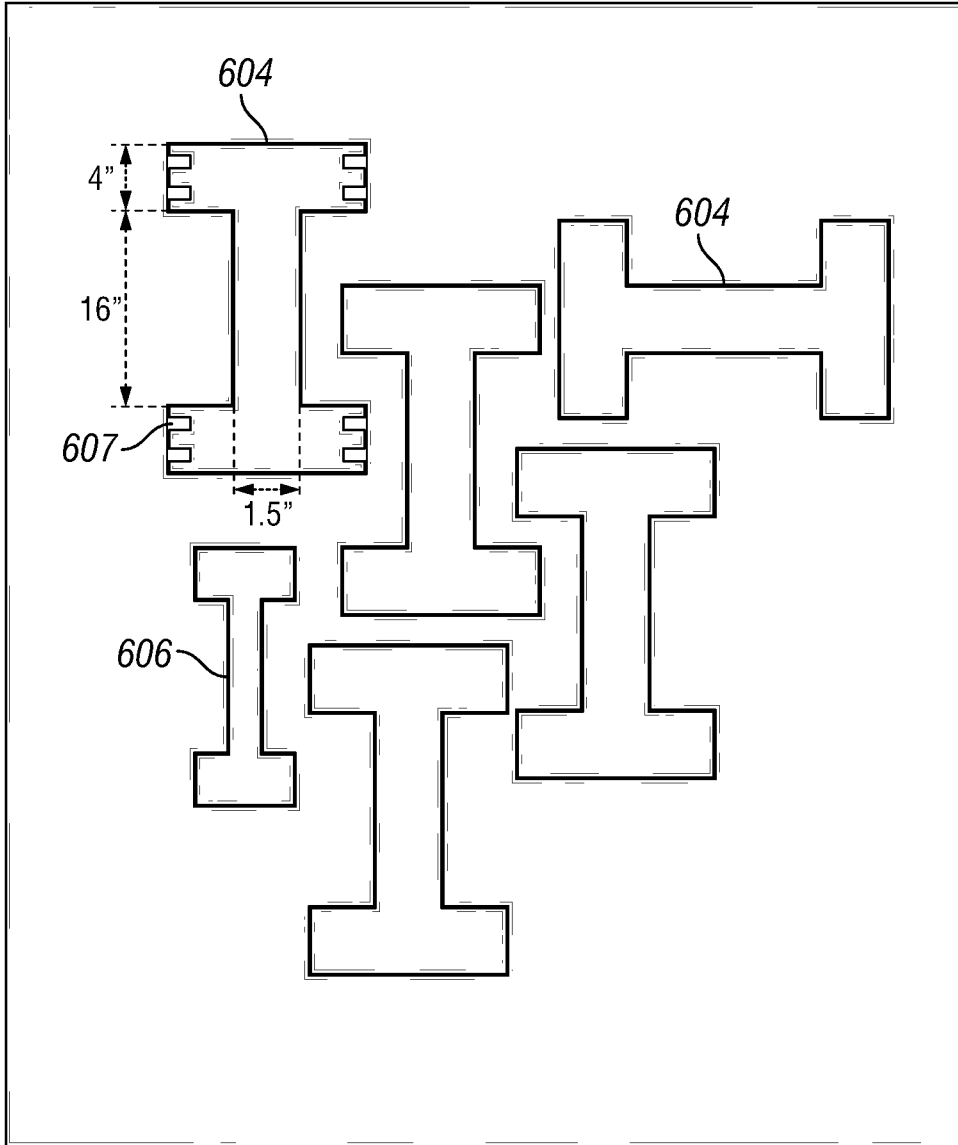

FIG. 6A

12/15

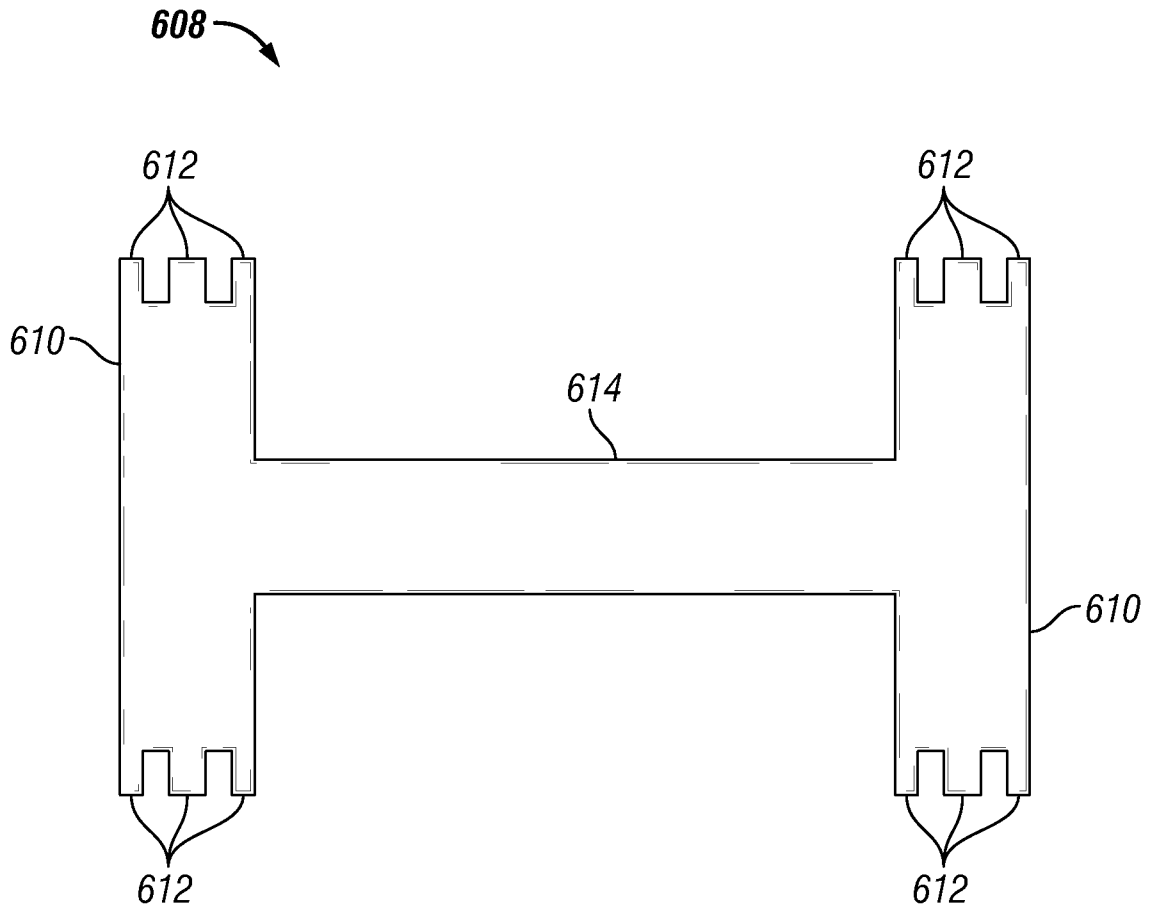
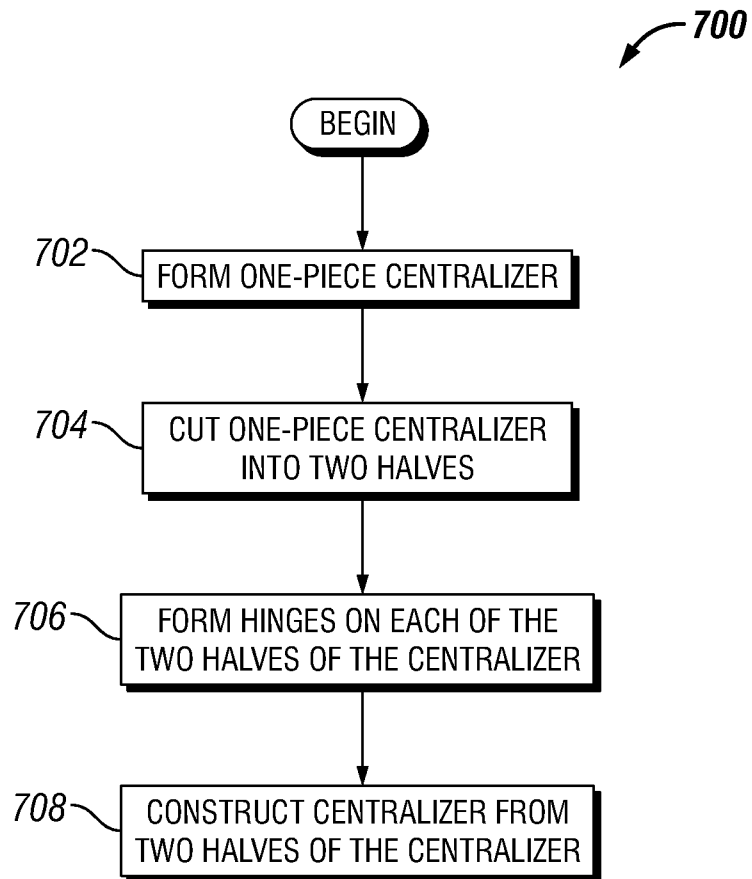
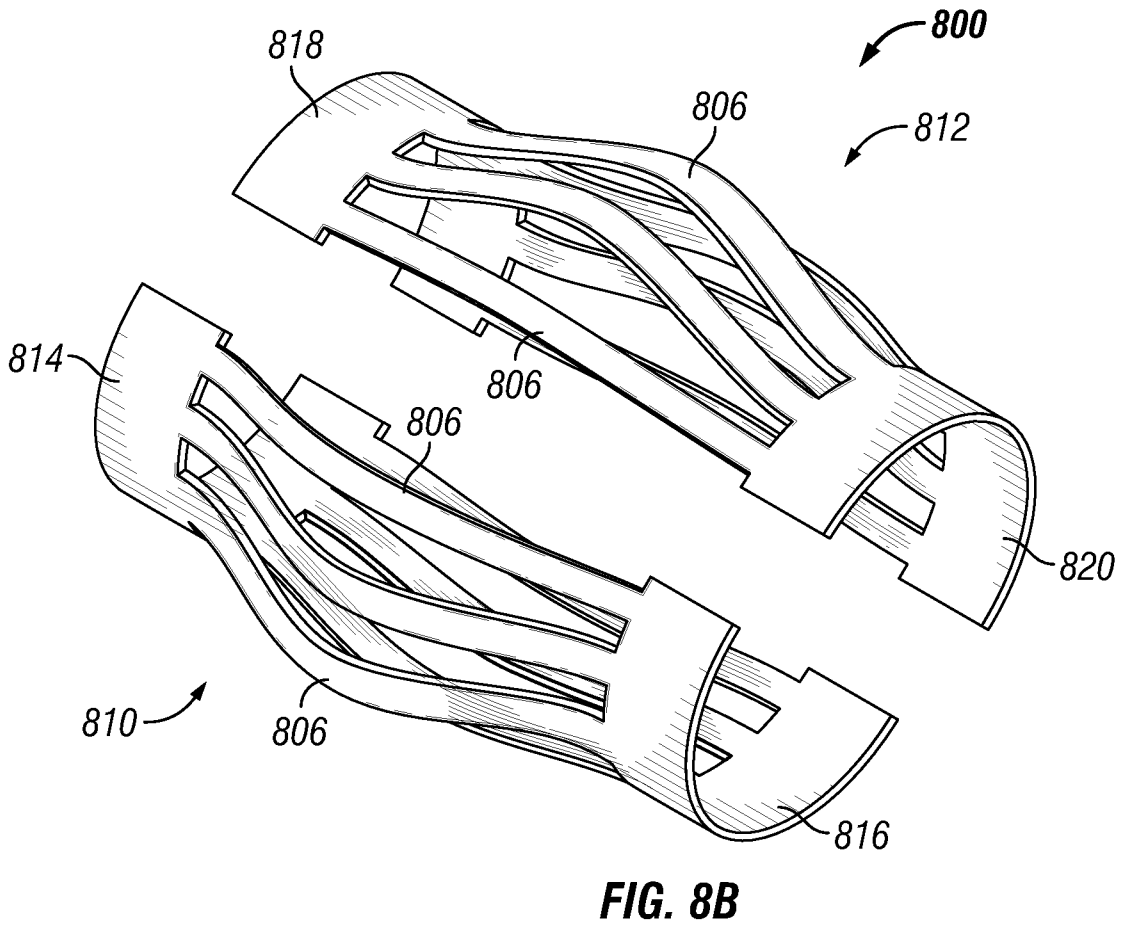
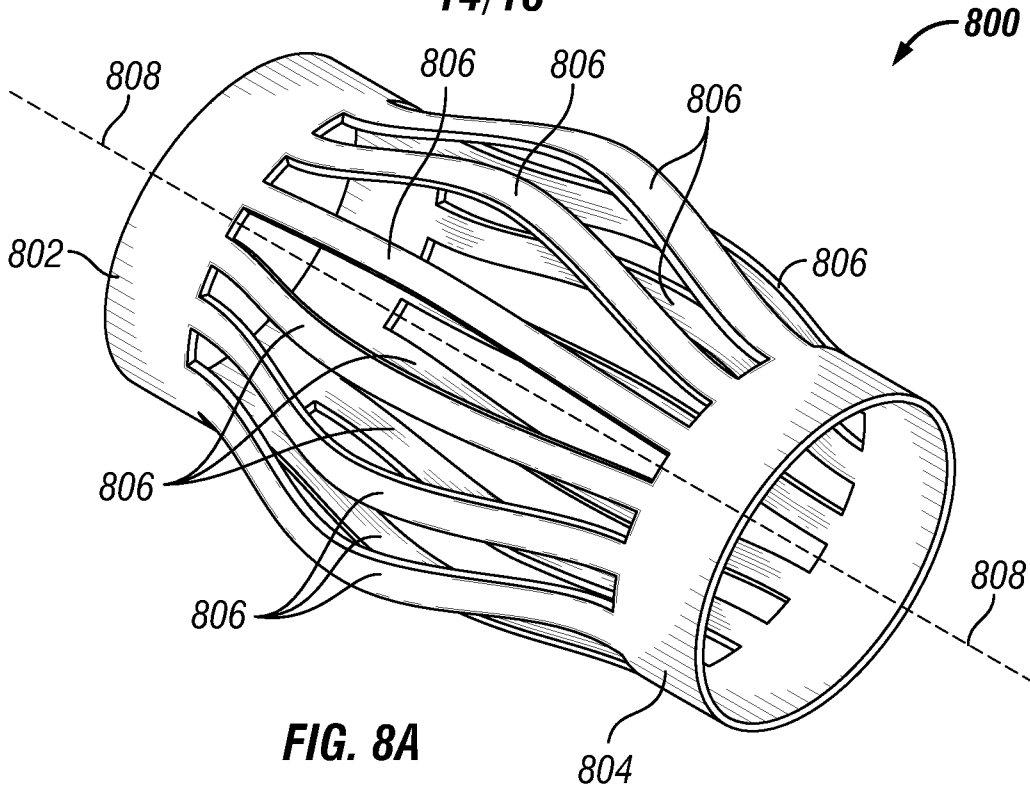

FIG. 6B

13/15**FIG. 7**

14/15



15/15

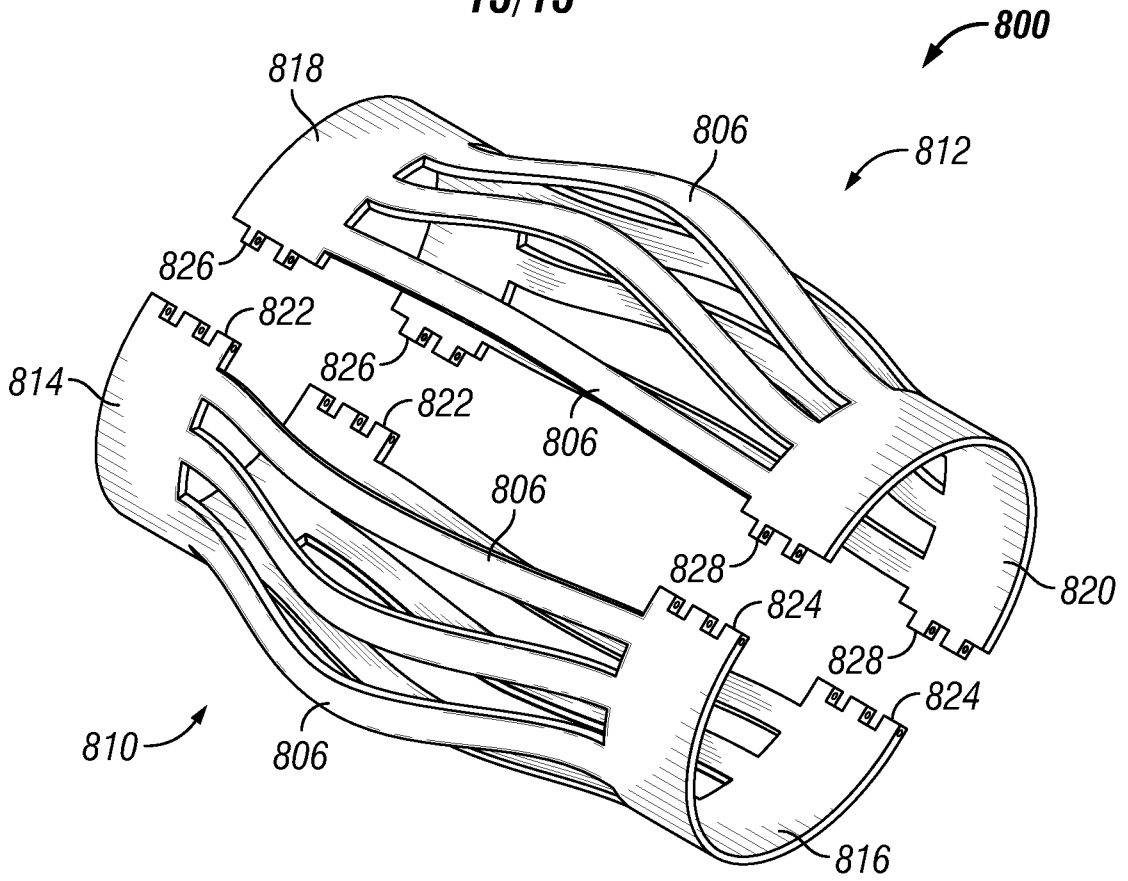

FIG. 8C

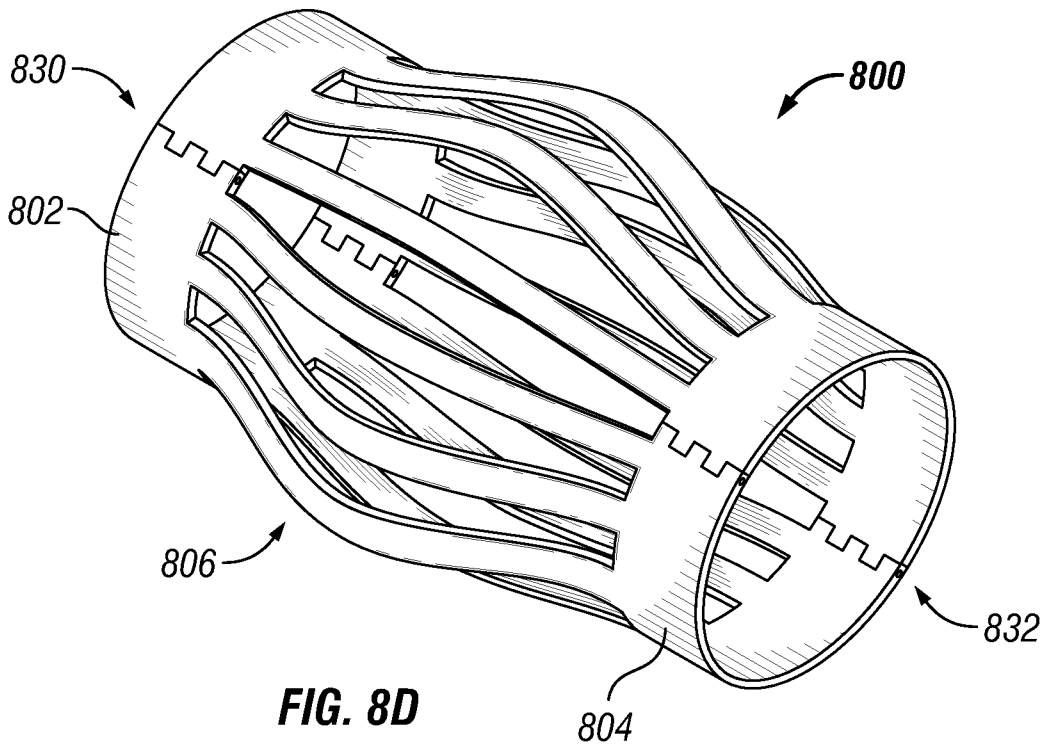

FIG. 8D

