



US00RE37331B1

(19) **United States**
(12) **Reissued Patent**
Schroeder

(10) **Patent Number:** **US RE37,331 E**
(45) **Date of Reissued Patent:** **Aug. 14, 2001**

(54) **DUAL-CONTROL SCHEME FOR IMPROVED MISSILE MANEUVERABILITY**

OTHER PUBLICATIONS

(75) Inventor: **Wayne K. Schroeder**, Mansfield, TX (US)

John H. Blakelock; *Automatic Control of Aircraft and Missiles*; 1991, ch. 7; pp. 229-259.

(List continued on next page.)

(73) Assignee: **Lockheed Martin Corporation**, Bethesda, MD (US)

Primary Examiner—Gary Chin

(74) *Attorney, Agent, or Firm*—Sidley & Austin; Stephen S. Sadacca

(21) Appl. No.: **09/315,919**

(22) Filed: **May 20, 1999**

(57) **ABSTRACT**

Related U.S. Patent Documents

Reissue of:

(64) Patent No.: **5,631,830**
Issued: **May 20, 1997**
Appl. No.: **08/383,720**
Filed: **Feb. 3, 1995**

A comparative dual-control strategy actuates forward and aft control devices simultaneously to significantly improve a missile's maneuverability/dynamic capability. A substantial, and measurable, operational effect of the inventive control strategy is a dramatic improvement in a missile's divert capability. To effect a maneuver in accordance with the inventive strategy, a missile's aft fins are initially deflected to generate a force OPPOSITE that conventionally used (pushing the missile's tail in the direction of the commanded maneuver) which simultaneously actuating forward thrusters to also push the missile's nose in the direction of the commanded maneuver but at a faster rate than the tail section. This causes the missile body to simultaneously rotate and translate in the direction of the commanded maneuver. Once a sufficient amount of aerodynamic force develops due to body rotation, the aft fins are deflected to generate a force that opposes the commanded maneuver to maintain a moment on the missile body and complete the commanded maneuver. An important benefit of cooperative dual-control strategy is that the missile begins to translate in the direction of the commanded maneuver immediately (conventional isolated aft control schemes do not accomplish this) and at a faster rate than is possible with either isolated forward control devices or an intuitive dual-control approach.

(51) **Int. Cl.**⁷ **G06F 19/00**
(52) **U.S. Cl.** **701/4; 244/3.21; 244/3.22**
(58) **Field of Search** **701/1, 3, 4; 244/3.21, 244/3.22, 3.1, 3.15, 176, 177**

(56) **References Cited**

U.S. PATENT DOCUMENTS

3,034,434 5/1962 Swaim et al. 102/50
3,139,033 6/1964 Geissler et al. 102/50

(List continued on next page.)

FOREIGN PATENT DOCUMENTS

0447284 9/1991 (EP) .
0489712 A2 6/1992 (EP) .
0489712 A3 6/1992 (EP) .
0604263 6/1994 (EP) .
2203223 10/1988 (GB) .
WO/88 04400 6/1988 (WO) .
WO/94 00731 1/1994 (WO) .

140 Claims, 17 Drawing Sheets

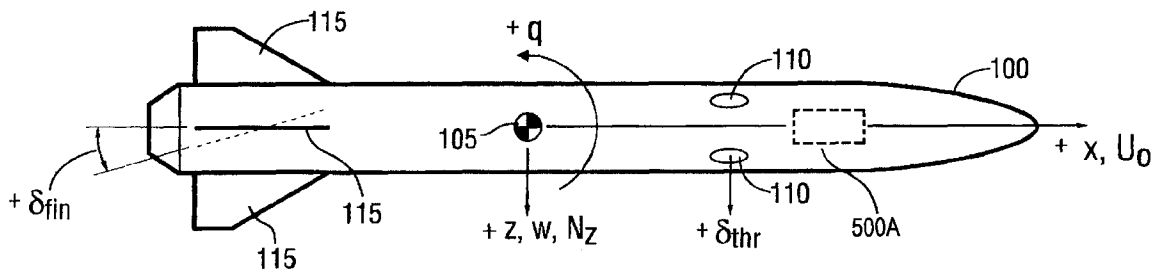

(New)

U.S. PATENT DOCUMENTS

3,282,541	11/1966	Webb	102/50
3,362,658	1/1968	Ito et al.	244/3.2
3,724,781	4/1973	Makow	244/3.23
4,116,404	9/1978	Howell	244/3.23
4,171,115	10/1979	Osder	244/181
4,531,693	7/1985	Raynaud et al.	244/52
4,589,594	5/1986	Kranz	239/265.25
4,624,424	11/1986	Pinson	244/3.21
4,699,333	10/1987	Pinson	244/3.21
4,830,311	5/1989	Pritchard et al.	244/3.15
4,867,393	9/1989	Faupell et al.	244/3.22
4,883,239	11/1989	Lachmann et al.	244/3.15
5,058,836	10/1991	Nobel	244/176
5,070,761	12/1991	Fidler	89/1.809
5,074,492	12/1991	Morgand	244/3.22
5,088,658	2/1992	Forsmo	244/3.21
5,094,406	3/1992	Shafer	244/3.21
5,123,611	6/1992	Morgand	244/3.22
5,259,569	11/1993	Waymeyer et al.	244/3.22
5,349,532	9/1994	Tilley et al.	364/459
5,393,012	2/1995	Dunn	244/3.23
5,439,188	8/1995	Depew, Jr. et al.	244/3.21

5,452,864	9/1995	Alford et al.	244/3.23
5,564,651	10/1996	Wiemer et al.	244/3.21
5,590,850	1/1997	Cannon et al.	244/3.15
5,593,109	1/1997	Williams	244/3.21
5,630,564	5/1997	Speicher et al.	244/3.24
5,679,919	10/1997	Holm et al.	102/377
5,806,791	9/1998	Hatalsky et al.	244/3.24
5,835,869	11/1998	Schroeder	701/4

U.S. PATENT DOCUMENTS

“An Appropriate Application of Fuzzy Logic: A Missile Autopilot for Dual Control Implementation”, Wayne K. Schroeder et al, *Proceedings from the 1994 IEEE International Symposium on Intelligent Control*, Aug. 16–18, 1994, Columbus, Ohio, pp. 93–98.

“Parameter Estimation Using A Back Propagation Neural Network”, Wayne K. Schroeder, Master’s Thesis, The University of Texas at Arlington, May 1990.

“Some Issues About Fuzzy Logic Control”, K. Liu et al, *Proceedings from the 32nd IEEE Conference on Decision and Control*, Dec. 15–17, 1993, San Antonio, Tex., pp. 1743–1748.

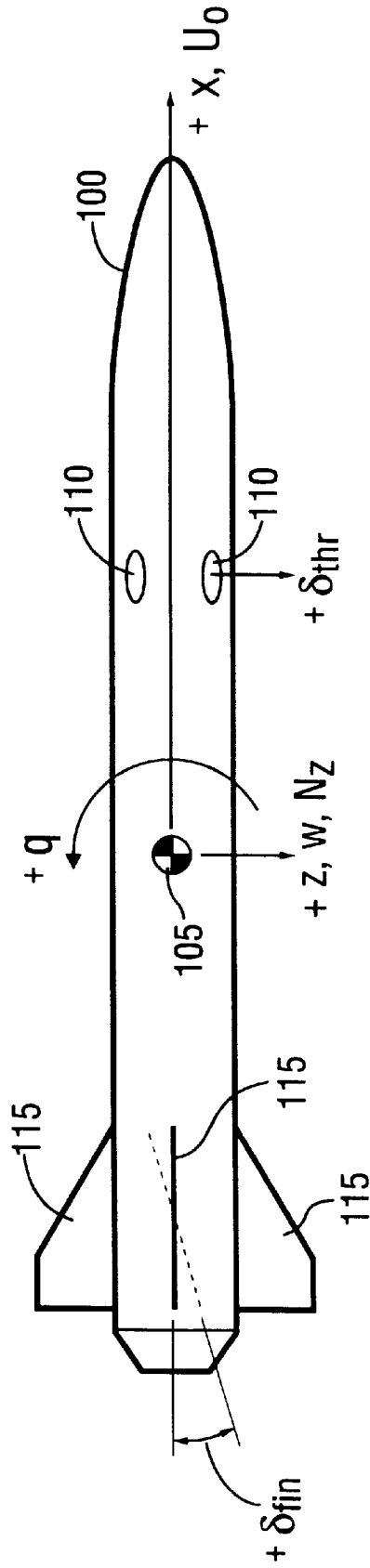

FIG. 1
(PRIOR ART)

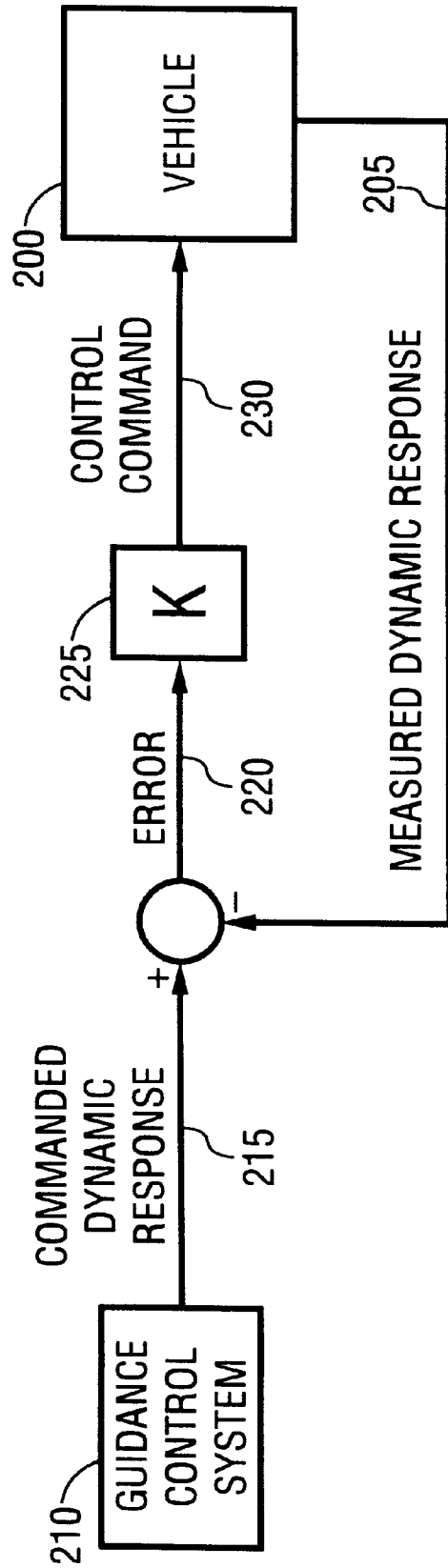

FIG. 2
(PRIOR ART)

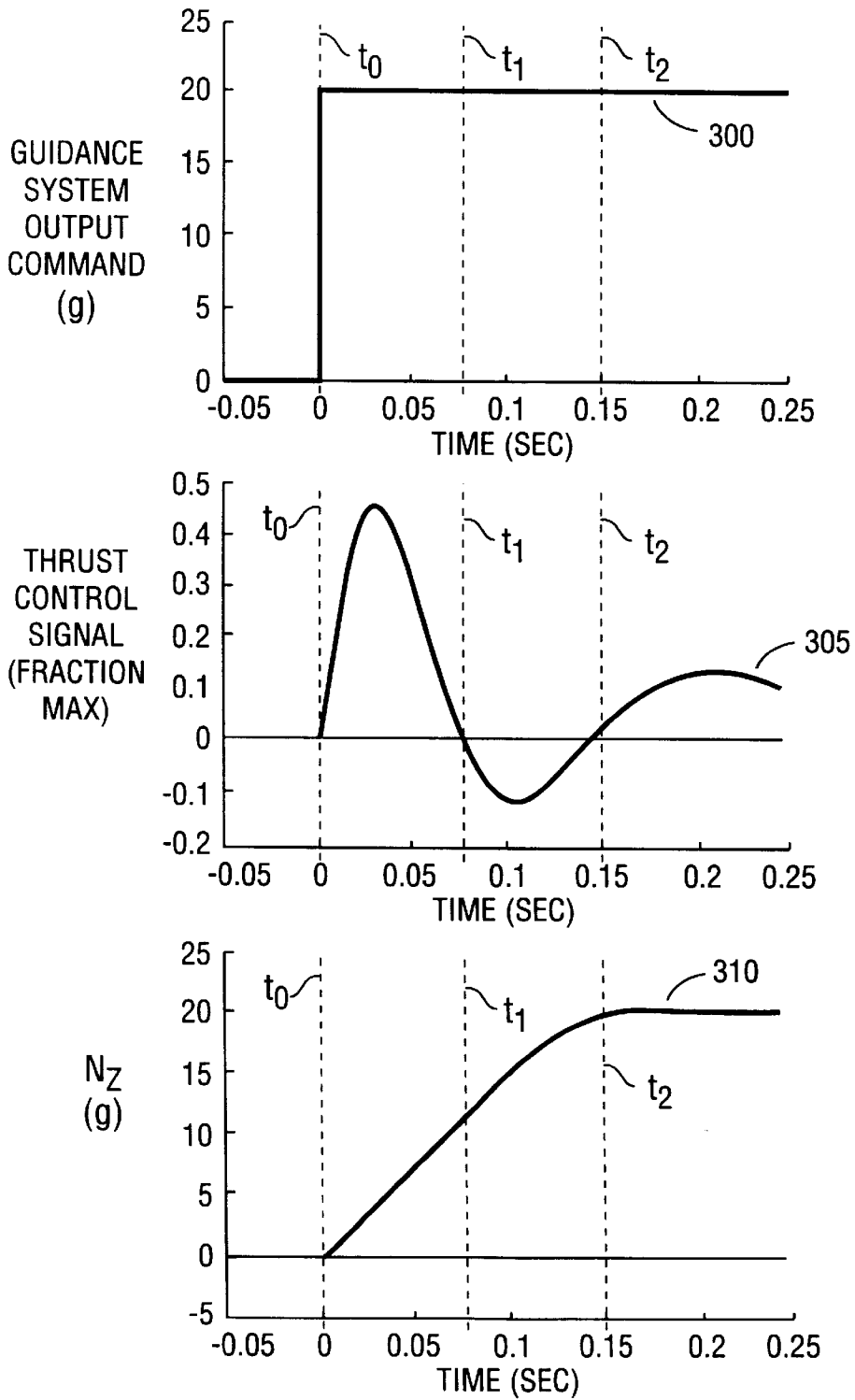

FIG. 3
(PRIOR ART)

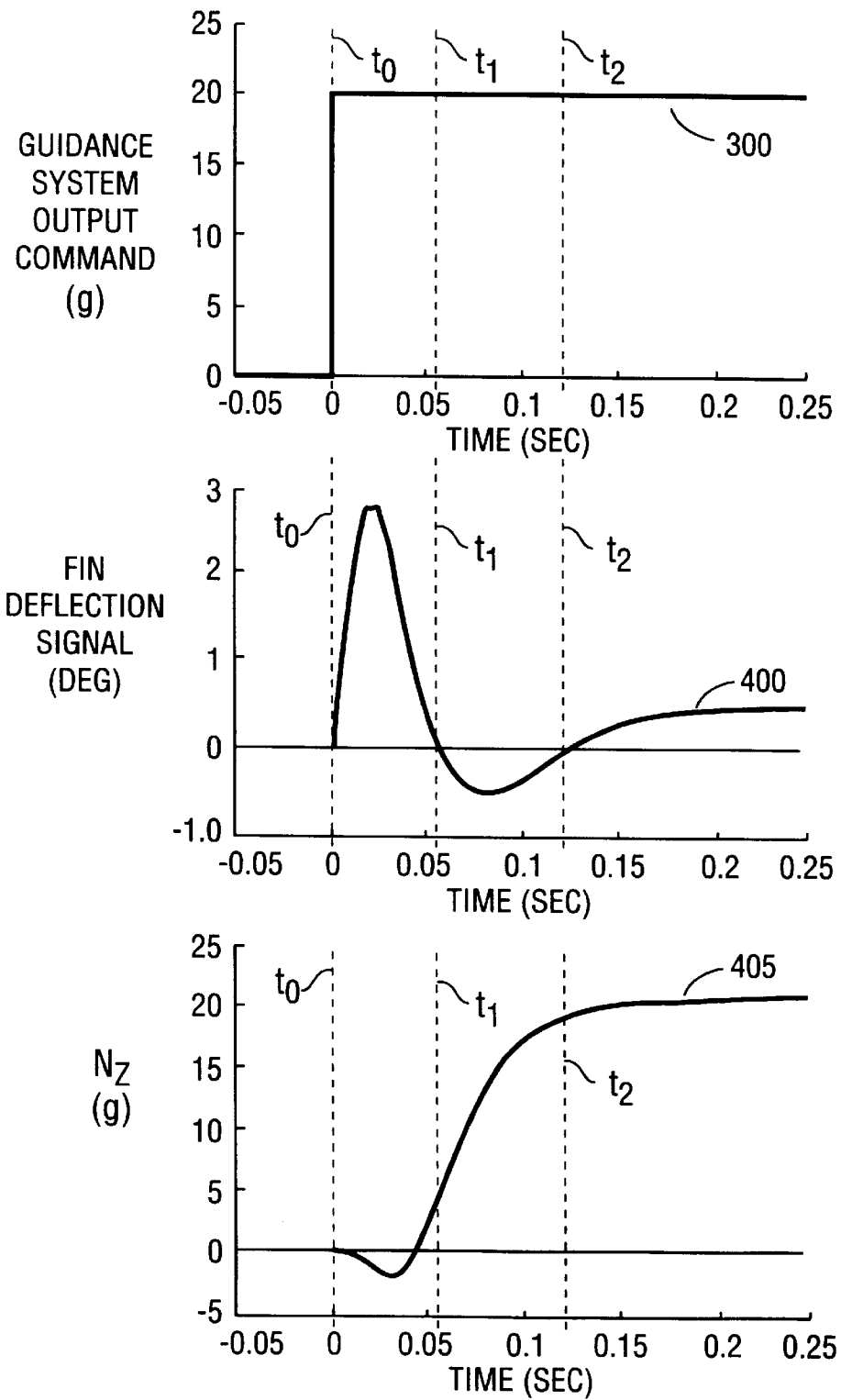

FIG. 4
(PRIOR ART)

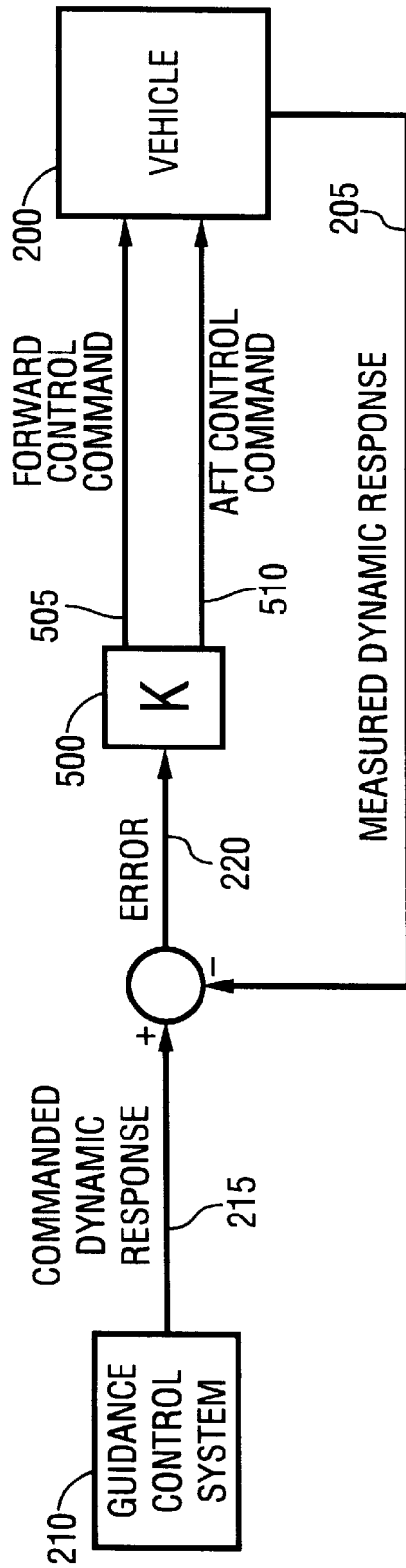

FIG. 5
(PRIOR ART)

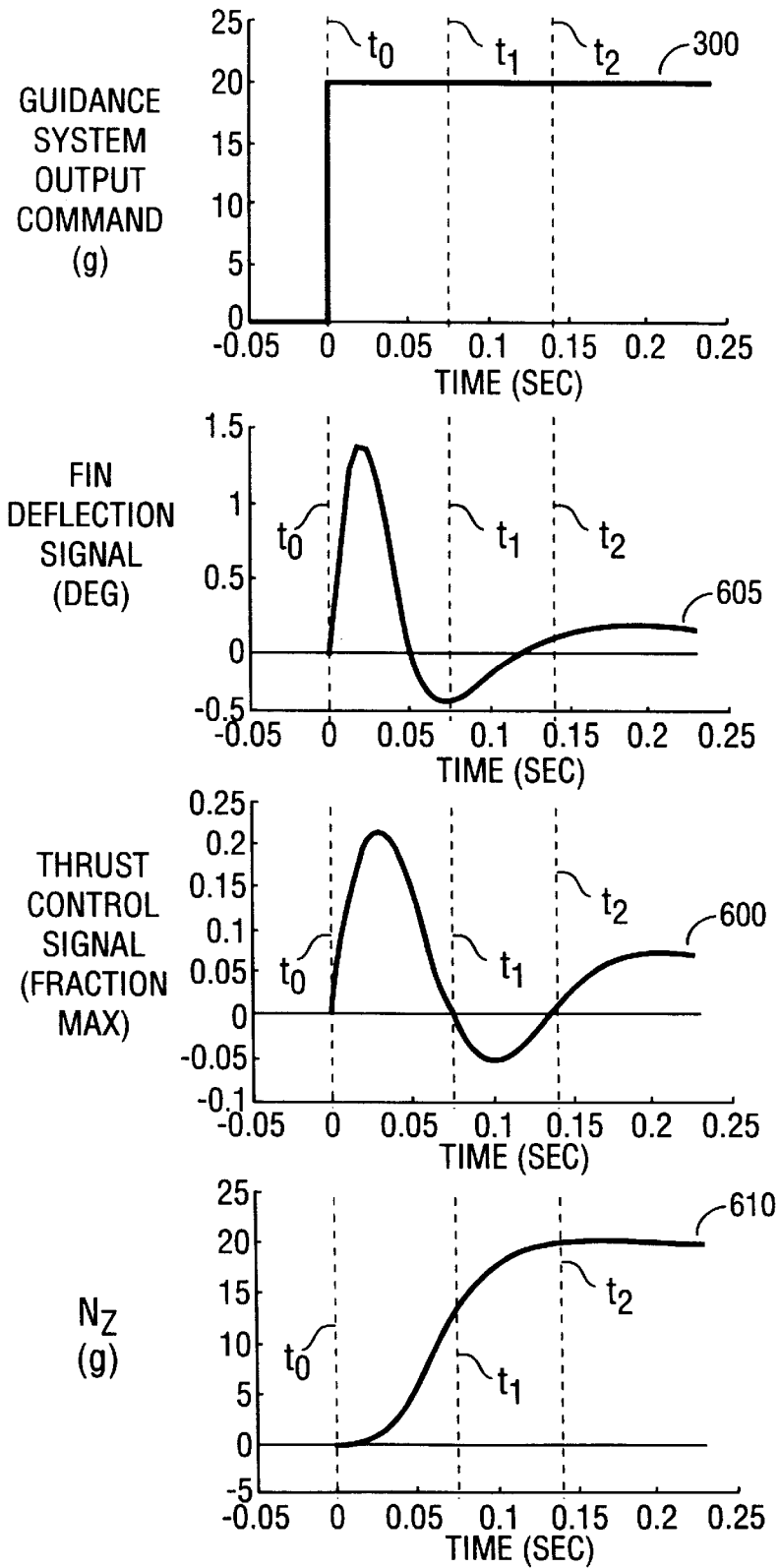

FIG. 6
(PRIOR ART)

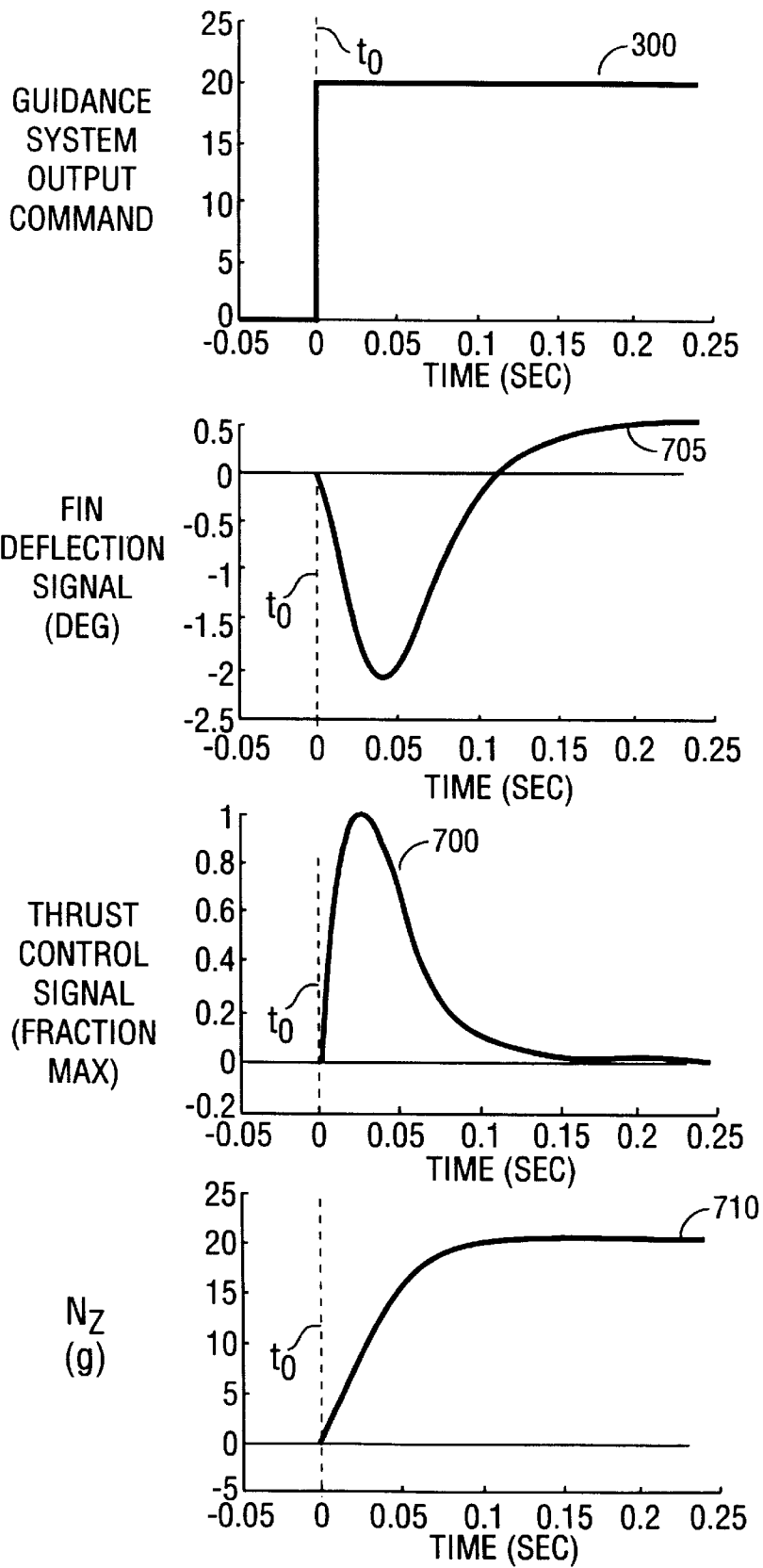

FIG. 7

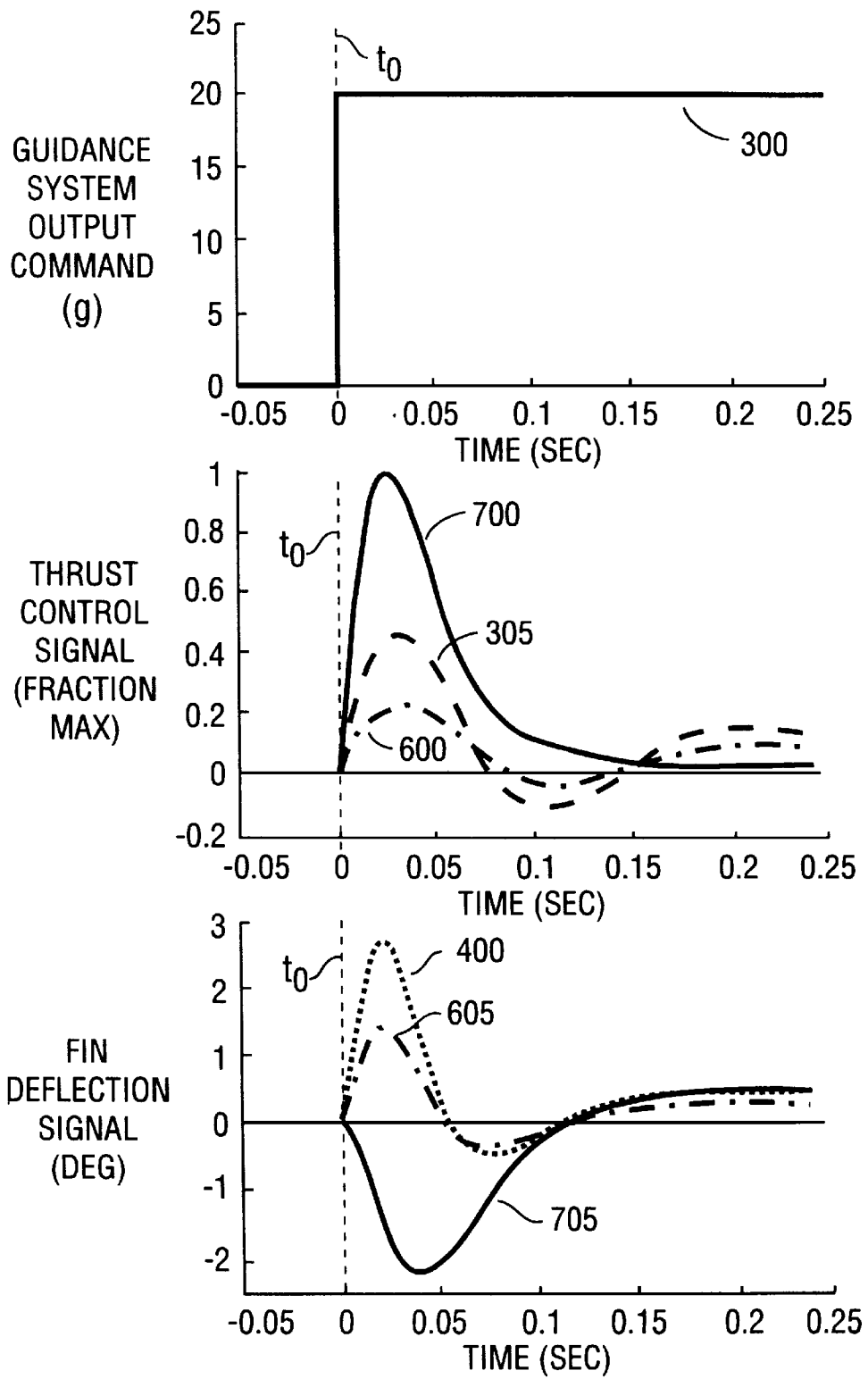

FIG. 8

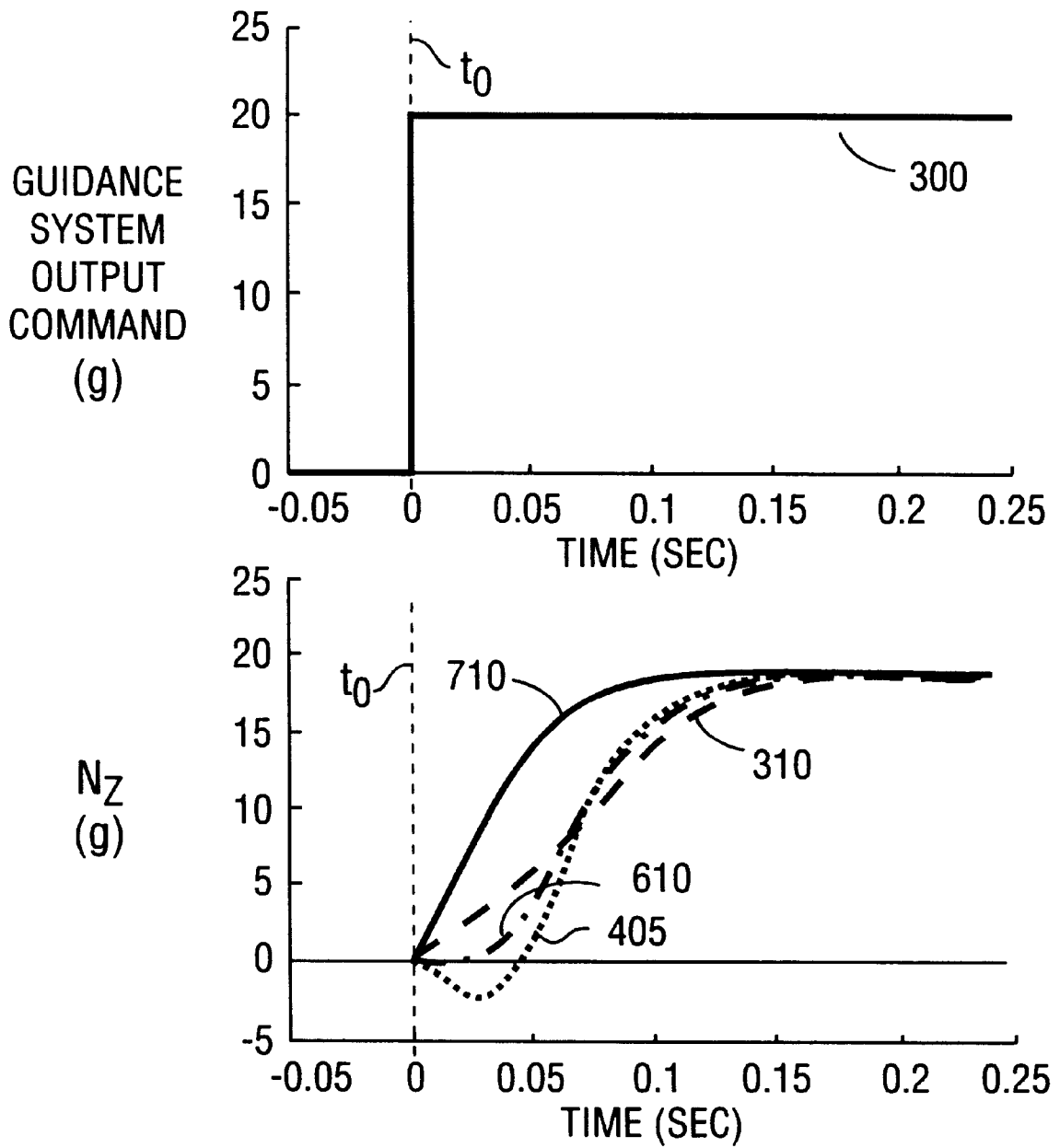

FIG. 9

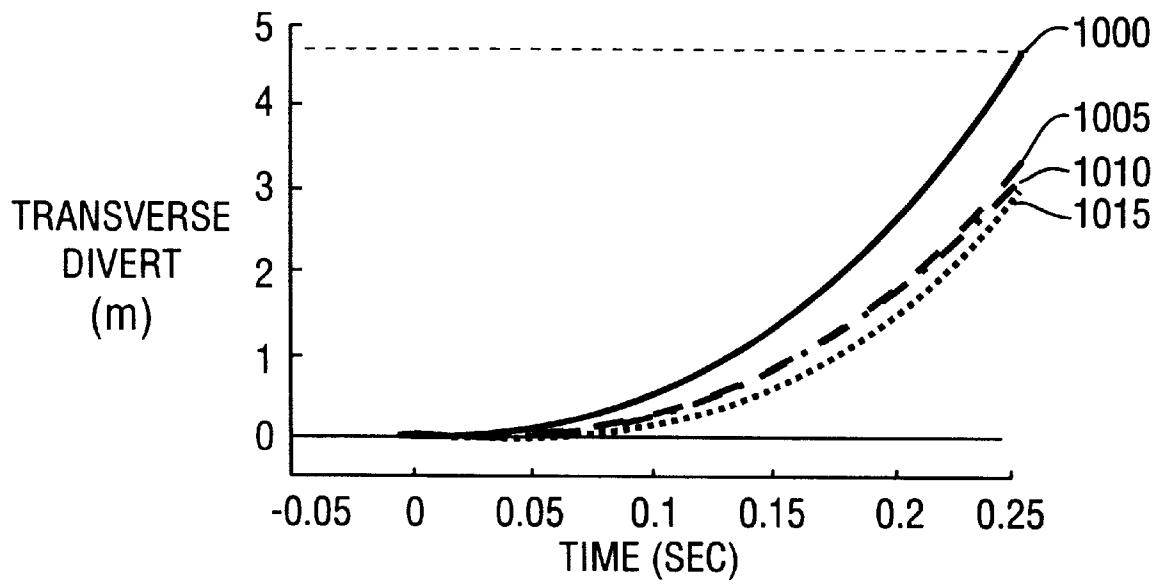

FIG. 10

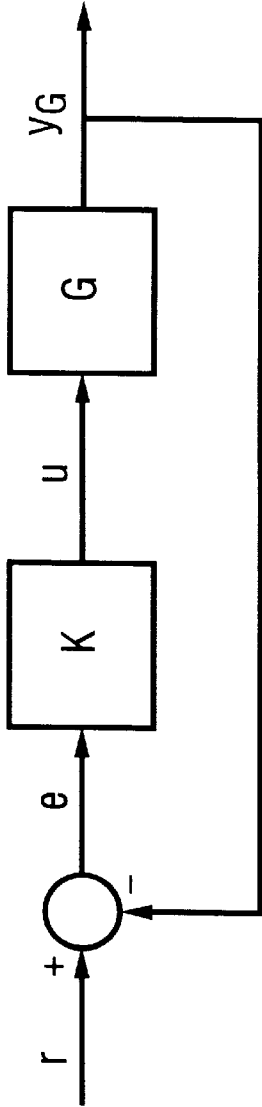

FIG. 11
(PRIOR ART)

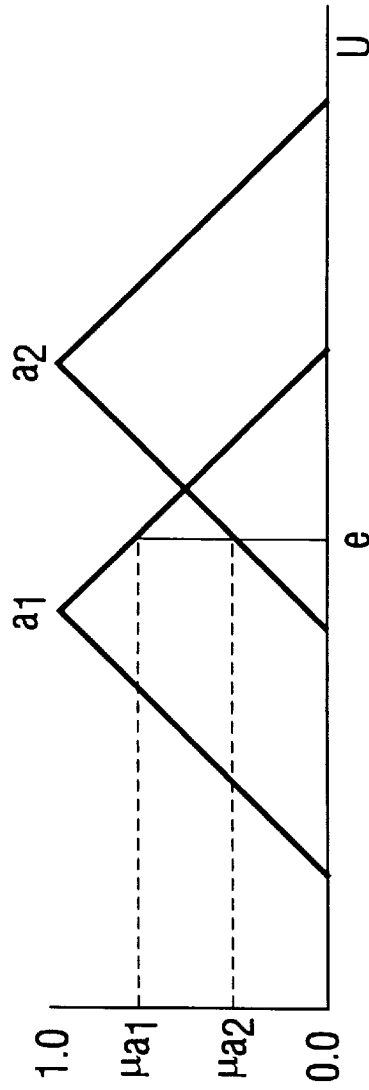

FIG. 12
(PRIOR ART)

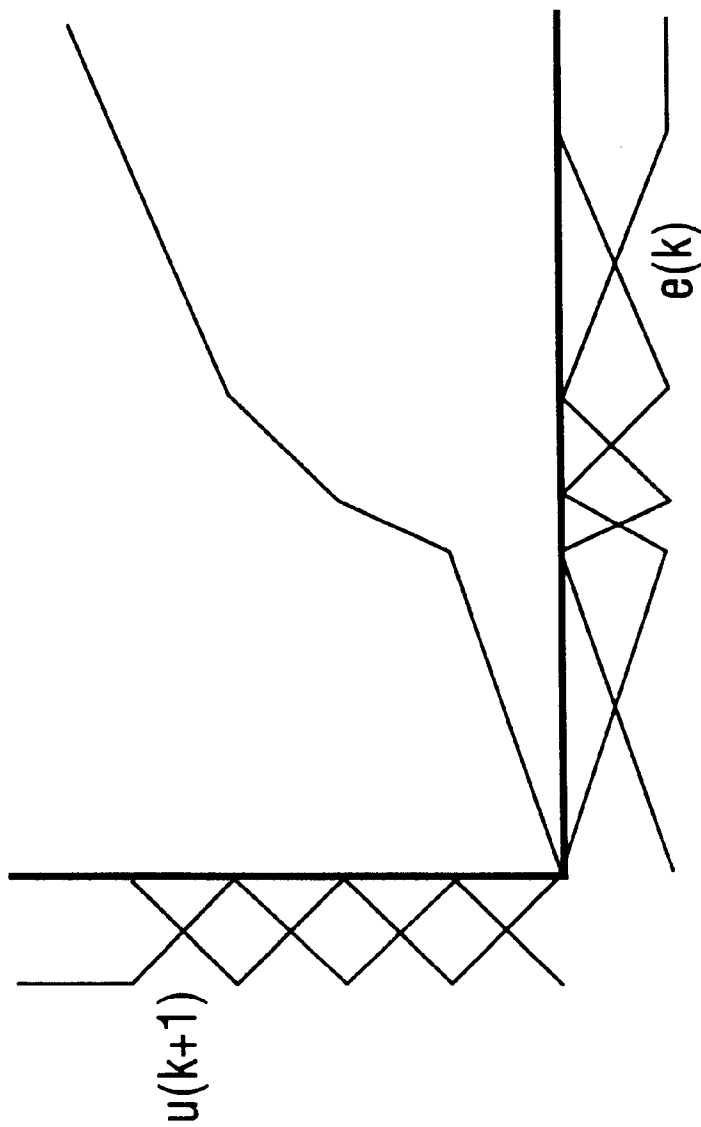

FIG. 13
(PRIOR ART)

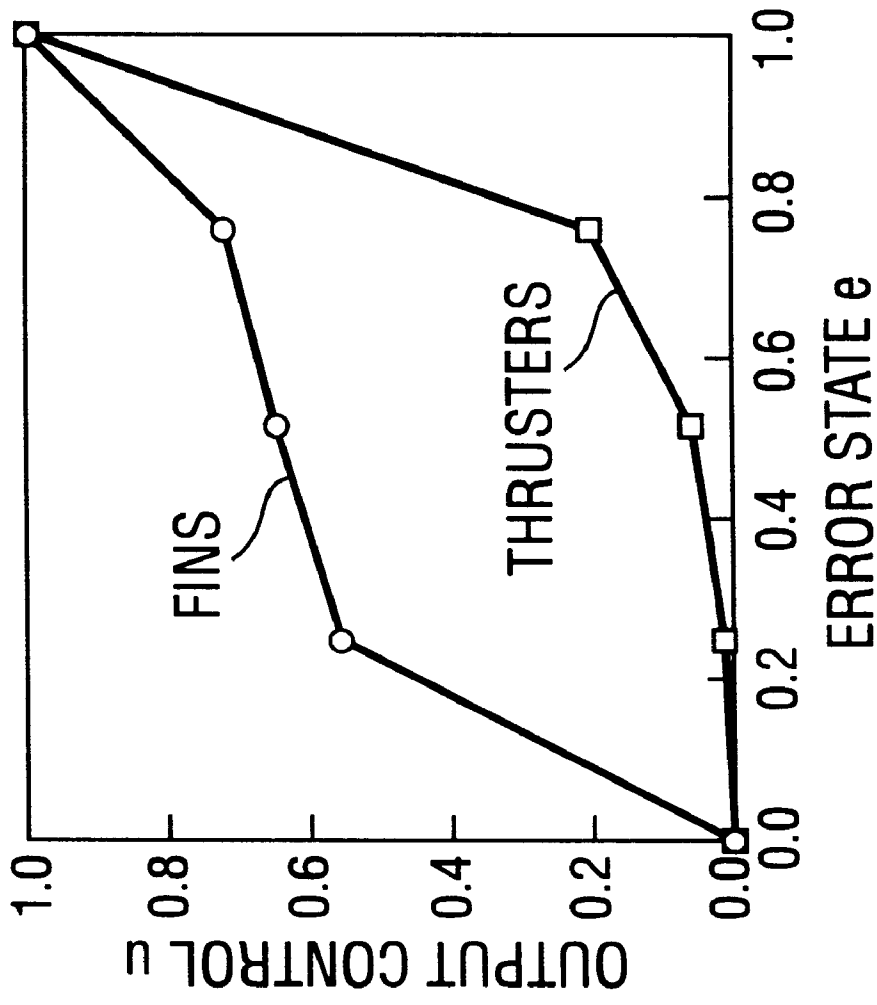

FIG. 14

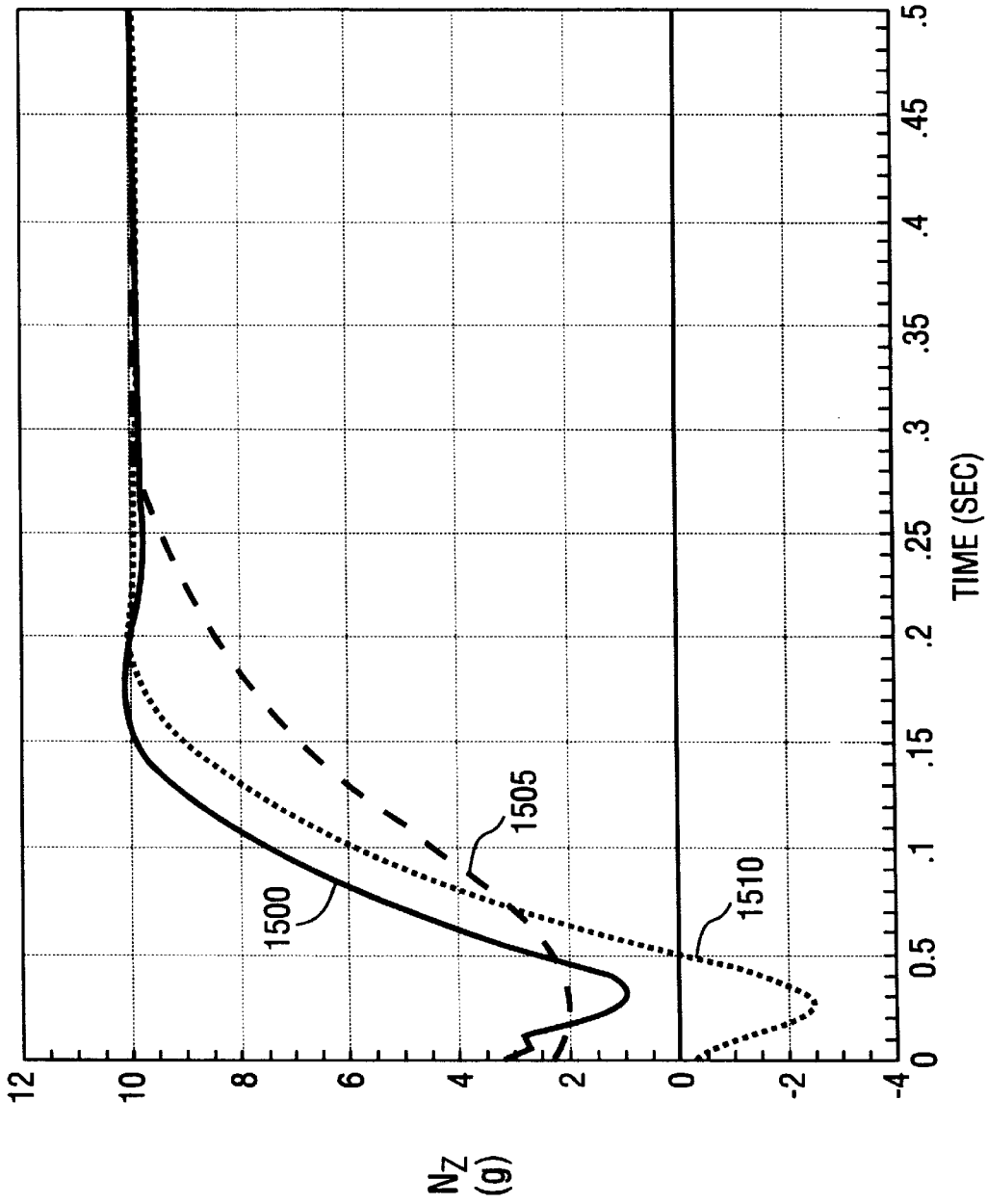

FIG. 15

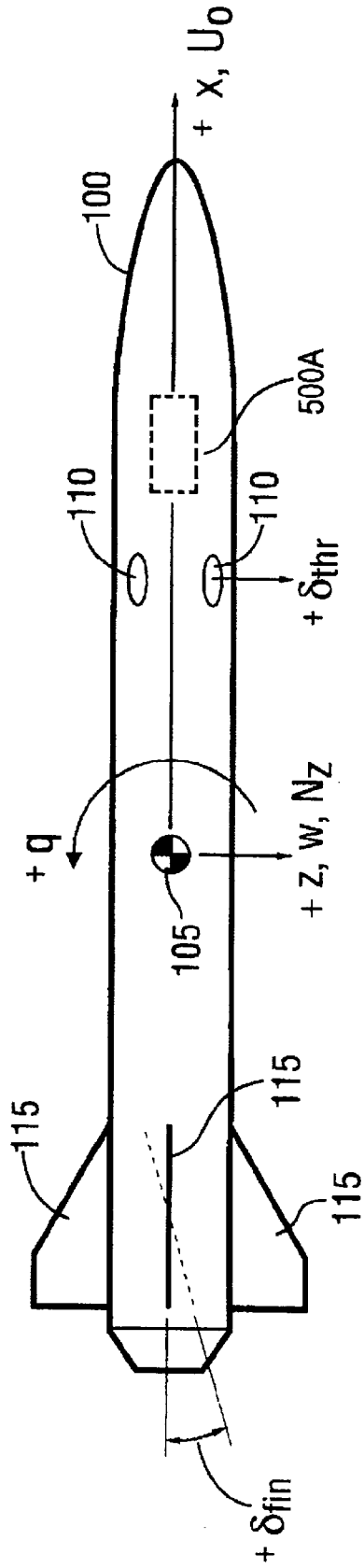

FIG. 16A (New)

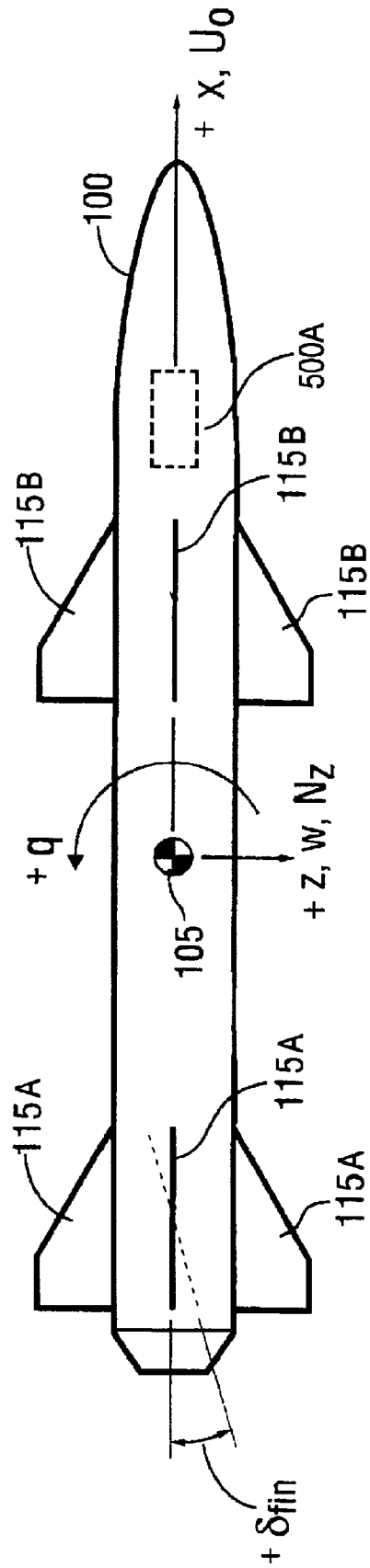

FIG. 16B (New)

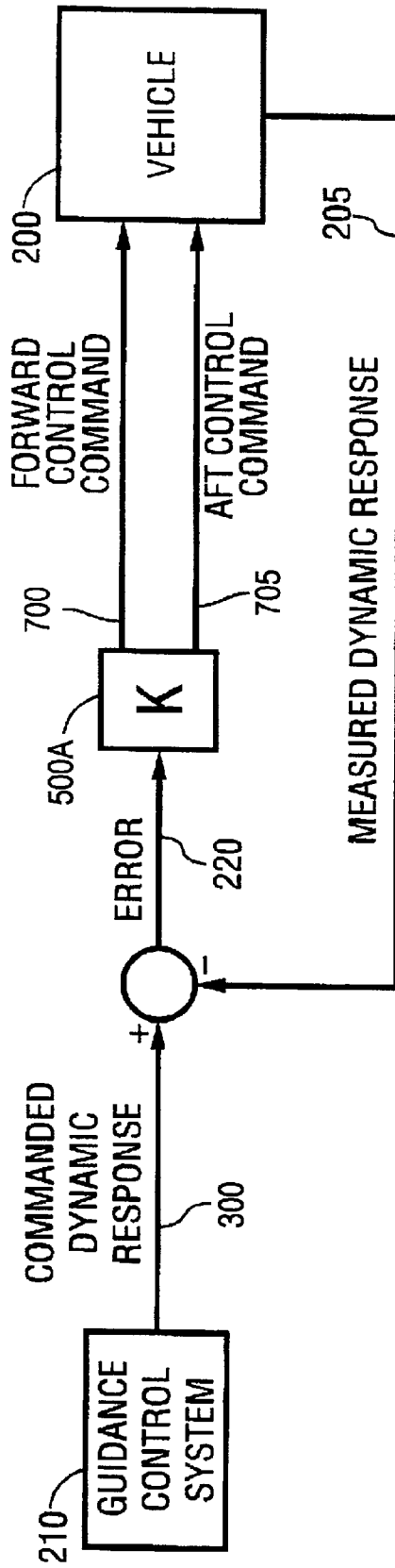

FIG. 17 (New)

DUAL-CONTROL SCHEME FOR IMPROVED MISSILE MANEUVERABILITY

Matter enclosed in heavy brackets [] appears in the original patent but forms no part of this reissue specification; matter printed in italics indicates the additions made by reissue.

1. FIELD OF THE INVENTION

The invention relates in general to the field of maneuver control of a vehicle traveling through a fluid environment (e.g., air, water, plasma) and more particularly to a maneuver strategy implementing dual-control devices to improve vehicle maneuverability. Specifically, the invention describes a dual-control autopilot that allocates control commands to two control mechanisms (positioned forward and aft of a vehicle's center of gravity) in such a manner as to provide increased dynamic capability.

2. BACKGROUND OF THE INVENTION

An application which exhibits an immediate need for the improved maneuverability provided by this invention is an interceptor missile. Enemy offensive missiles pose an escalated challenge for interceptor missiles. [Modem] Modern threat configurations are designed to realize reduced radar signatures, make use of expanded countermeasures, travel at extremely high velocities over unpredictable or difficult to predict trajectories, and employ large magnitude lateral evasive maneuvers. In order to accomplish body-to-body impact, the interceptor missile must achieve large transverse acceleration levels in a very short period of time to move the vehicle perpendicular to its flight path to ensure collision.

As shown in FIG. 1, a missile system can be described as an elongated body 100 that travels through a fluid medium. The missile 100 has a forward section and an aft section divided by a point of center of gravity 105. Forward of the center of gravity 105 is a forward control device such as thrusters 110. The aft section has an aft control device such as fins 115. It will be apparent to one of ordinary skill in the field that other alternative control devices are possible. For instance, the forward control device could be implemented as canards rather than a thrusters. Similarly, the aft control device could be implemented via thrust-vector controls techniques.

FIG. 1 shows the vehicle configuration, sign convention, and notation used in this discussion for a body fixed coordinate system allowing motion in the x-z plane. Table 1 describes the notation introduced in FIG. 1.

TABLE 1

Notation	
Symbol	Description
x	longitudinal body fixed (right-hand) Cartesian coordinate
y	transverse body fixed (right-hand) Cartesian coordinate
z	Universe body fixed (right-hand) Cartesian coordinate
N _z	transverse acceleration load factor along body axis z
q	missile pitch rate about body axis y
U ₀	longitudinal velocity along body axis x
w	transverse velocity along body axis z

TABLE 1-continued

Notation	
Symbol	Description
$\delta_{\beta a}$	aft fin deflection angle
δ_{tr}	magnitude of applied thrust force

A missile moves in a transverse direction in response to an applied control force according to the laws of physics. Below the altitude of approximately 20 kilometers, a missile's primary source of transverse acceleration is the aerodynamic force resulting from the missile body being at an angle with its velocity vector (angle of attack). Flight control devices (e.g., forward thrusters 110 and/or aft fins 115) obtain this angle of attack by applying to rotate the missile's front end in the direction of the intended maneuver.

A functional block diagram of a conventional missile control system is shown in FIG. 2. Block 200 represents the physical vehicle (i.e., the missile) and incorporates all vehicle subsystems including, for example, control actuation, propulsion and inertial measurement systems as well as aerodynamic configuration. The vehicle's measured dynamic response is shown as feedback signal 205. This signal encodes, for example, a measurement of the missile's 100 rotational and translational rates and accelerations. The missile guidance logic shown in block 210 provides a commanded dynamic response signal 215 which encodes a desired maneuver along a kinematic trajectory. The difference between the desired and measured responses produce the error signal 220 in a conventional feedback architecture. The autopilot controller 225 uses the error signal to generate a control signal 230. This control signal encodes commands to actuate the vehicle's control devices. For example, the control signal 230 could be degrees of deflection of a fin or canard, or degrees of deflection of a rocket motor nozzle, or percentage of maximum thrust of an attitude control motor, etc.

2.1 Forward Control Device Systems

One type of conventional missile control system employs a forward control device only. An example of this type of missile system is the FLAGE missile designed by LTV Aerospace Corporation (now Loral Vought Systems, the assignee of this application). The FLAGE missile employs active control of forward thrusters to achieve maneuverability. In the FLAGE missile, aft fins are fastened in a fixed canted position to provide stabilization and rolling characteristics.

A conventional control scheme employing a forward control device (e.g., thrusters) only is shown in FIG. 3. In response to a command signal 300 (corresponding to command signal 215) from the guidance system 210 for a desired step increase in lateral acceleration in the positive z-direction, the missile's autopilot controller 225 generates a time varying thruster command signal 305 (corresponding to control signal 230) to effect the maneuver. Actuation of the lateral control thrusters produce the measured acceleration response 310 in the positive z-direction normal to the vehicle's body. It is conventional to illustrate the acceleration by normalizing with the missile's weight producing a load factor N_z having the units of g-force.

At time t₀ guidance system output (215 and 300) commands a step increase in positive z-axis acceleration. Referring to signals 305 and 310, between times t₀ and t₁ the autopilot controller 225 commands the forward thrusters to deliver a force 305 in the positive z-direction to rotate the

missile's nose in the positive z-direction **310** (also known as a negative pitching moment). Between times t_1 and t_2 , the autopilot controller commands the thrusters to deliver a negative force **305** to slow the missile's downward rotation. After time t_2 , the autopilot controller commands a positive force **305** to hold a steady rate and acceleration in the positive z-direction **310**. (Note, one skilled in the art will realize that this description also applies to accelerations in other directions.)

It is important to note that forward control mechanisms achieve missile rotation by applying a force in the direction of the maneuver, that is, ALL missile acceleration **310** is in the direction of the maneuver.

2.2 Aft Control Device Systems

Another conventional missile control technique employs an aft control device only. Examples include the Patriot missile system (Raytheon), VT-1 missile system (Loral Vought Systems) and the ATACMS missile system (Loral Vought Systems). In these systems, active control of the aft flight control surfaces (fins or thrusters) are employed to achieve maneuverability.

A conventional control scheme employing an aft control device (fins) only is shown in FIG. 4. In response to a command signal **300** (corresponding to command signal **215**) from the guidance control system **210** for a step increase in acceleration in the positive z-direction, the missile's autopilot controller **225** generates a fin control signal **400** (corresponding to the control signal **230**) to effect the maneuver. Signal trace **405** represents the missile's measured transverse acceleration response N_z from the missile's inertial measurement system (corresponding to the feedback signal **205**), where N_z is described above with respect to FIG. 3.

At time t_0 , guidance system output (**215** and **300**) commands a step increase in positive z-axis acceleration. Between times t_0 and t_1 the autopilot controller **225** sends a command signal **400** (corresponding to control signal **230**) to actuate the missile's aft fins to deflect in a direction opposite the desired maneuver (sign convention denotes this as a positive deflection, refer to FIG. 1), producing an aerodynamic force on the fin surfaces in the negative z-direction. This force on the fins momentarily accelerates the missile's body in a direction opposite the commanded maneuver, thus introducing an inherent delay in the maneuver. Rotation of the missile's aft end causes the missile nose to pitch downward and the missile body to eventually accelerate in the positive z-direction. Between times t_1 and t_2 , the autopilot controller **225** commands the aft fins to deflect in the same rotational direction as the maneuver, producing a fin force in the direction of the maneuver and causing the missile rotation to slow. After time t_2 , the autopilot controller commands a fin deflection in a direction opposite the maneuver, producing an opposing force and a rotation in the direction of the maneuver to maintain a steady rate and transverse acceleration in the positive z-direction. (Note, one skilled in the art will realize that this description also applies to accelerations in other directions.)

It is important to note that aft control mechanisms achieve missile accelerations by applying a force, initially, in the direction OPPOSITE the maneuver, see [410] **400**, which causes an inherent delay in the missile's response to the commanded maneuver, see **405**.

2.3 Dual-Control Device Systems

The amount of control authority available to the missile is, in general, bounded by the length and diameter dimensions of the missile's airframe **100**. Putting two control devices—

dual-control strategy—on a single missile increases the amount of control moment which can be applied to the vehicle and, therefore, enlarges the missile's potential for increased maneuverability.

While some conventional missile control systems, such as the PAC-3 (Loral Vought Systems), employ both forward and aft control devices, they do not employ them in a cooperative manner for planar maneuvers. That is, the forward control device may be used to control the vehicle's pitch maneuver, while the aft control device may be used simultaneously to control the vehicle's roll motion.

A functional block diagram of an autopilot control system employing the dual-control concept is shown in FIG. 5. Block **200** represents the physical vehicle, including all vehicle subsystems such as control actuation, propulsion and inertial measurement systems. Output from the inertial measurement system (encoding, for instance, measured system roll, pitch and yaw rates and transverse accelerations) is shown as feedback signal **205**. Measured vehicle response **205** is compared with a commanded dynamic response signal **215** from the guidance control system **210** to create an error signal **220** in a conventional feedback architecture. The dual-control autopilot controller **500** uses the error signal **220** to generate a forward control signal **505** and an aft control signal **510**. It is the missile control signals **505** and **510** that control the missile's forward and aft control devices such as thrusters **110** fins **115**.

2.4 An Intuitive Approach to Improving Missile Maneuverability

Dual-control of competitive devices has not heretofore been used in a cooperative manner because it is a challenging control problem. The difficulty in implementing a dual-control strategy lies in being able to allocate how much of the desired maneuver should be the responsibility of each control mechanism. That is, how much should the forward control device be actuated and how much should the aft control device be actuated to effect the commanded dynamic response.

Since the maneuverability of the missile is obtained via application of moments by the fore and aft control devices, intuition suggests that the fastest response using a dual-control strategy should be obtained by having the two control devices apply the largest controllable moment couple. In other words, an intuitive approach to improving a missile's dynamic capability is to simply use the individual forward and aft control strategies—the same command shapes as shown in FIGS. 3 and 4—but appropriately scaled. A control mechanism employing this approach is shown in FIG. 6. In response to a command signal **300** from the guidance control system **210** for a step increase in acceleration in the positive z-direction, the missile's autopilot controller **500** generates a thruster control signal (**505** and **600**) and a fin control signal (**510** and **605**) to effect the maneuver. Element **610** represents the missile's measured transverse acceleration response N_z (corresponding to feedback signal **205**) to the commanded maneuver, where N_z is described above with respect to FIG. 3.

It is important to note that using this intuitive control strategy, the vehicle's acceleration in the commanded directions is delayed with respect to a isolated forward control strategy (compare **310** and **610**). As previously noted, this delay is caused by the applied fin force being in a direction opposite that of the desired motion. It is recognized in the field that use of aft control devices introduce an inherent delay in missile response. Thus, the intuitive approach to improving a missile's dynamic capability using a dual-

control strategy suggests that the command signals to fore and aft control devices be scaled in such a manner as to provide the desired acceleration.

3. SUMMARY OF THE INVENTION

A cooperative dual-control strategy actuates forward and aft control devices simultaneously to significantly improve a missile's maneuverability/dynamic capability. To effect a maneuver in accordance with the inventive strategy, a missile's aft fins are initially deflected to generate a force OPPOSITE that conventionally used (pushing the missile's tail in the direction of the commanded maneuver) while simultaneously actuating forward thrusters to also push the missile's nose in the direction of the commanded maneuver but at a faster rate than the tail section. This causes the missile body to simultaneously rotate and translate in the direction of the commanded maneuver. Once a sufficient amount of aerodynamic force develops due to body rotation, the aft fins are deflected to generate a force that opposes the commanded maneuver to maintain a moment on the missile body and complete the commanded maneuver. An important benefit of cooperative dual-control strategy is that the missile begins to translate in the direction of the commanded maneuver immediately (conventional isolated aft control schemes do not accomplish this) and at a faster rate than is possible with either isolated forward control devices or an intuitive dual-control approach. A key operation benefit of the invention is a dramatically improved missile divert capability.

It is as important distinction in the inventive control strategy that the aft fin control command, during the early portion of the maneuver, is in a direction OPPOSITE that conventionally used for the maneuver. (If the forward control system is unable to apply a significant enough moment, the fins may briefly be used to augment the thruster moment and then be used as a force generating device at low angles of attack). After this initial movement, the fins are deflected in a direction conventional for the maneuver. In cooperation with the aft fin control, forward thruster control is applied in the direction expected for the maneuver.

4. BRIEF DESCRIPTION OF DRAWINGS

FIG. 1 is a diagram of a missile system showing the missile's center of gravity and a conventional right-hand coordinate system.

FIG. 2 is a block diagram of a conventional missile control system employing a single (either forward or aft) control device.

FIG. 3 illustrates a conventional control scheme employing a forward (thruster) control device.

FIG. 4 illustrates a conventional control scheme employing an aft (fin) control device.

FIG. 5 is a block diagram of a missile control system that uses both forward (thruster) and aft (fin) control devices.

FIG. 6 illustrates a conventional dual-control architecture for a missile having forward (thruster) and aft (fin) control devices.

FIG. 7 illustrates a dual-control scheme in accordance with the invention for a missile having forward thrusters and aft fin control devices.

FIG. 8 illustrates the difference between forward and aft control signals of conventional missile control schemes, those of an intuitive dual-control scheme, and those control signals generated in accordance with the invention.

FIG. 9 illustrates the difference in missile responses between conventional missile control schemes, those of an

intuitive dual-control scheme, and the response generated by a dual-control scheme in accordance with the invention.

FIG. 10 illustrates the improved missile divert capability of the inventive dual-control strategy over conventional fin isolated or thruster isolated control strategies and an intuitive dual-control scheme.

FIG. 11 shows a block diagram for a generalized control system for the purposes of describing a fuzzy logic based controller implemented in accordance with the invention.

FIG. 12 shows a graphical representation of a triangular membership fuzzy-rule.

FIG. 13 shows the nonlinear variation between error and control signals in an illustrative fuzzy logic implementation of the inventive control strategy.

FIG. 14 shows the forward and aft control command signal magnitude shaping employed by a cooperative dual-control system for a fuzzy logic based embodiment of the inventive control strategy.

FIG. 15 shows the transverse acceleration (simulated) responses for isolated control mechanisms compared with the response obtained with a cooperative dual-control strategy in accordance with the invention.

FIGS. 16A and 16B are diagrams of missile systems employing the present invention.

FIG. 17 is a block diagram of a missile control system according to the present invention that uses both forward and aft control devices.

5. DETAILED DESCRIPTION OF A SPECIFIC EMBODIMENT

One illustrative embodiment of the invention is described below as it might be implemented using a cooperative dual-control strategy. In the interest of clarity, not all features of an actual implementation are described in this specification. It will of course be appreciated that in the development of any such actual implementation (as in any control system development project), numerous implementation-specific decisions must be made to achieve the designer's specific goals, such as compliance with system- and business-related constraints, which will vary from one implementation to another. Moreover, it will be appreciated that such a development effort might be complex and time-consuming, but would nevertheless be a routine undertaking of a aerodynamic control systems engineer of ordinary skill having the benefit of this disclosure.

A portion of the disclosure (section 5.3) of this patent document contains material which is subject to copyright protection. The copyright owner has no objection to the facsimile reproduction by anyone of the patent disclosure, as it appears in the Patent and Trademark Office patent files or records, but otherwise reserves all copyright rights whatsoever.

FIGS. 16A and 16B show missile systems including an autopilot controller 500A in accordance with the present invention. As with the conventional missile system shown in FIG. 1, the missile systems of FIGS. 16A and 16B each have a forward section (or portion) and an aft section (or portion) divided by a point of center of gravity. FIG. 16A shows a missile system having as an aft control device fins 115 and as a forward control device thrusters 110, while FIG. 16B shows a missile having as an aft control device fins 115A and as a forward control device canards 115B. While the various figures show missile systems having aft fins and forward thrusters or canards, it will be apparent to one of skill in the field that each of the forward and aft control devices can be implemented by either fins or thrusters.

5.1 Inventive Control Strategy

A dual-control strategy in accordance with the invention actuates forward and aft control devices simultaneously to significantly improve a missile's maneuverability/dynamic capability. To effect a maneuver in accordance with the invention a missile's aft fins are initially deflected to generate a force OPPOSITE that conventionally used (i.e., pushing the missile's tail in the direction of the commanded maneuver) while simultaneously actuating forward thrusters to also push the missile's nose in the direction of the commanded maneuver but at a faster rate than the tail section. This causes the missile body to simultaneously rotate and translate in the direction of the commanded maneuver. Once a sufficient amount of aerodynamic force develops due to body rotation, the aft fins are deflected to generate a force that opposes the commanded maneuver (i.e., as conventionally done) to maintain a moment on the missile body and complete the commanded maneuver. An important benefit of the inventive strategy is that the missile begins to translate in the direction of the commanded maneuver immediately (conventional isolated aft control schemes do not accomplish this) and at a faster rate than is possible with either isolated forward control devices or an intuitive dual-control approach as discussed above.

A functional block diagram of an autopilot control system employing the dual-control concept is shown in FIG. 17. Block 200 represents the physical vehicle, including all vehicle subsystems such as control actuation, propulsion and inertial measurement systems. Output from the inertial measurement system (encoding, for instance, measured system roll, pitch and yaw rates and transverse accelerations) is shown as feedback signal 205. Measured vehicle response 205 is compared with a commanded dynamic response signal 300 from the guidance control system 210 to create an error signal 220 in a conventional feedback architecture. The dual-control autopilot controller 500A uses the error signal 220 to generate a forward control command 700 and an aft control command 705.

Behavior of a dual-control system in accordance with the invention is shown in FIG. 7. In response to a command signal 300 from the guidance control system 210 for a step increase in acceleration in the positive z-direction, the missile's autopilot controller [500] 500A generates a [thruster control signal (505 and 700)] thruster control signal (i.e., forward control command) 700 and a [fin control signal (510 and 705)] fin control signal (i.e., aft control command) 705 to effect the maneuver. Signal trace 710 represents the missile's measured (from the inertial measurement system, corresponding to signal 205) transverse acceleration response N_z to the commanded maneuver, where N_z is described above with respect to FIG. 3. While FIG. 7 illustrates the forward control command as a thruster control signal and the aft control command as a fin control signal, depending on the configuration of the vehicle, each of the forward and aft control commands may be either a thruster or fin control command.

It is an important distinction in the inventive control strategy that the aft fin control command 705, during the early portion of the maneuver, is in a direction OPPOSITE that conventionally used for the maneuver. (If the forward control system is unable to apply a significant enough moment, the fins may briefly be used to augment the thruster moment and then be used as a force generating device at low angles of attack). After this initial movement, the fins are deflected in a direction conventional for the maneuver; compare 705 with 400 and 605. In cooperation with the aft fin control, forward thruster control is applied in the direc-

tion expected for the maneuver; compare 700 with 305 and 600. FIGS. 7 and 8 illustrate that in the inventive strategy the thruster control signal 700 and the fin control signal 705 can be initiated substantially simultaneously and, more particularly, can be initiated simultaneously at time t_0 .

FIGS. 7 and 8 further illustrate that a period of time, during which the fin control signal 705 actuates a force in the direction of the commanded maneuver (i.e., the time period of the initial peak for signal 705 in FIGS. 7 and 8 that actuates a force in the direction of the commanded maneuver) can have a major portion that overlaps a major portion of a period of time during which the thruster control signal 700 actuates a force in the direction of the commanded maneuver (i.e., the time period of the initial peak for signal 700 in FIGS. 7 and 8 that actuates a force in the direction of the commanded maneuver).

FIGS. 7 and 8 further illustrate that a time period of the initial peak of the thruster control signal 700 that actuates a force in the direction of the commanded maneuver can overlap substantially all of the time period of the initial peak of the fin control signal 705 that actuates a force in the direction of the commanded maneuver. Also, substantially all of the fin control signal 705 that actuates a force in the direction of the commanded maneuver can overlap a portion of the thruster control signal 700 that actuates a force in the direction of the commanded maneuver.

FIGS. 7 and 8 further illustrate that during a time period of 0.1 second beginning with the initiation of the thruster control signal 700, a major portion of the cumulative effect of the force actuated by the fin control signal 705 (i.e., the area under the fin deflection signal curve 705) acts in a direction, with respect to the aft end, that is substantially the same as the direction of the commanded maneuver.

The invention takes advantage of the physical phenomena that, although the forces generated by the forward and aft control devices are an order of magnitude less than the aerodynamic forces available at high angles of attack, at low angles of attack control device generated forces are the significant forces contributing to the commanded maneuver. As a hypothetical example, suppose that a missile 100 is in flight when the guidance system 210 sends a dynamic response command signal 215 to the autopilot controller 500 indicating that the missile's nose should be moved downward in the positive z-direction. In accordance with the inventive control strategy, the aft control fins 115 are first deflected to push the aft end of the missile downward (i.e., opposite the direction traditionally expected for a positive z-direction maneuver) while the forward thrusters 110 are also fired to push the nose of the missile in the positive z-direction. The key is that the missile's nose is moving more rapidly in the positive z-direction than its aft end. This, in turn, is a result of the force and moment generated by the rapid acting thrusters.

As the vehicle begins to rotate, increasing the aerodynamic force on the missile body due to increasing angle of attack, the fins are deflected to take over as the primary moment generating device while the use of the forward thruster is reduced to conserve their limited propulsive fuel resources. When the fins are being used as the primary moment generating device, they are deflected in the expected (i.e., conventional) direction, that is, to generate a force in a direction opposite the maneuver. Thus, in the initial stages of the maneuver fins are primarily used as a force generating device while in the maneuver's later stages they are primarily used as a moment generating device. The manner in which the fins are transitioned from a force

generating device, where they generate a moment that opposes the maneuver, to a moment generating device, where they generate a force that opposes the maneuver, is done in a manner to provide the desired dynamic response.

As would be known to those of ordinary skill in the field, the manner in which this control surface transition is accomplished to provide the desired dynamic response is a function of the missile's specific design and would include, for instance, the amount of available control force from the forward and aft control devices, the vehicles aerodynamic characteristics, and the missile's flight condition (velocity, altitude, etc.).

A comparison of control signal strategies highlights the novelty of the instant approach to improving missile maneuverability. FIG. 8 compares the autopilot controller output for a forward control strategy only (305), an aft control strategy only (400), an intuitive dual-control strategy (600 and 605), and a dual-control scheme in accordance with the invention (700 and 705). A similar comparison of missile acceleration profiles, shown in FIG. 9, highlights the advantage of the inventive approach.

It will be appreciated by one of ordinary skill in the field that the performance of any vehicle making use of the invention dual-control strategy can be monitored via vehicle telemetry. This allows a convenient method of evaluating the controllers effectiveness in a specific implementation. Alternatively, vehicle telemetry offers a means of determining if a vehicle is using the inventive control strategy.

5.2 Improved Divert Capability of the Inventive Control Strategy

The purpose of an interceptor missile is to intercept or "kill" an enemy missile (even when the enemy missile is executing high-g evasive maneuvers). This, in turn, requires an interceptor missile be able to translate laterally as quickly as possible. The maximum lateral distance a missile can translate in a specified period of time, defined in an inertial reference frame, is known as the missile's divert capability.

A key operational benefit of the inventive dual-control strategy is a dramatically improved missile divert capability. To illustrate this important improvement, consider the situation in which an interceptor missile approaches a high speed target which executes an evasive maneuver [requiring] the interceptor to counter with its maximum divert capability.

FIG. 10 shows the simulated divert capability (in response to a 20 g command from the interceptor's guidance control system) for a missile with the following configuration: traveling at mach 3, sea level altitude, weight of 48 Kilograms (Kg), length of 2.64 meters, diameter of 16.5 centimeters (cm), aft fin span of 11.4 cm, and a divert thrust of 3114 Newtons. As shown, a 20 g guidance command produces a 4.7 meter divert 1000 using the inventive control strategy in a relevant time frame of 0.25 seconds. This compares to a 3.4 meter divert 1005 with isolated thruster control, a 3.2 meter divert 1010 with the intuitive dual-control approach, and a 3.1 meter divert 1015 with the isolated fin control. The resulting divert capability can be directly correlated to increased capability against maneuverable targets or used to offset guidance sensor uncertainties.

5.3 Fuzzy-Logic Embodiment of the Inventive Control Strategy

This section contains, in substantial part, a paper presented by the inventor at the 1994 IEEE International Symposium on Intelligent Control in Columbus, Ohio, U.S.A. on Aug. 17, 1994 and describes a controller in

accordance with the invention implemented using fuzzy logic techniques.

Fuzzy logic has the ability to produce a nonlinear mapping from conditions in error space to actions in control command space. This property translates to the ability to improve response time to a step input as exemplified with a two degree of freedom, pitch plane autopilot for a supersonic missile. More notably, it is further demonstrated that the fuzzy logic methodology can address a set of performance indices which can be ambiguously stated but are intuitively important. An example of a missile controlled simultaneously with two competitive control mechanisms is used to illustrate where this advantage is relevant and desirable.

5.3(a) Fuzzy Logic

Fuzzy logic is a mathematical discipline based on fuzzy set theory which allows for degrees of truth and falseness. Fuzzy logic in a controller maps a set of inputs called antecedents to a set of control command outputs called consequents which will appropriately actuate devices to translate the system to the desired state. Because of the multi-valued nature of fuzzy logic, the values of the system states can be categorically described by linguistic variables which maintain the intuitive knowledge or feel the engineer has for the system. For example, rates may be described as "positive fast" or "negative slow" and control actions may be classified as "negative large" or "positive medium," etc. What has been criticized by some as ad-hoc tuning is in truth a minimization technique where the engineer has conceptualized and applied an ambiguous set of performance indices.

Consider the generalized feedback control system shown in FIG. 11 where G is the system plant (equivalent to vehicle 200), y_G is the vector of measured response (equivalent to the measured dynamic response 205), r is the vector of input command levels (equivalent to the commanded dynamic response 215), the vector e is the difference between the desired command levels and the measured responses or error state (equivalent to error signal 220), K is the stabilizing controller (equivalent to the autopilot controller 225), and u is the vector of commands for the control actuation system (equivalent to the composite control signal comprising forward and aft control commands, 505 and 510 respectively). If K is chosen to be based on fuzzy logic, the error state at a discrete time point is correlated with the desired controller command u in three steps: 1) Fuzzification, 2) Rule Evaluation, and 3) Defuzzification.

Fuzzification is the process of characterizing each error state being input to the controller over a range of values called the universe of discourse, U . It is helpful for tuning purposes to normalize each U by a typical maximum value of its associated error state. Each universe of discourse is divided into multiple overlapping subsets defined by a membership function and labeled by a linguistic variable such as "positive large." A distinct or "crisp" value of an error state may belong to more than one subset on U and the degree of membership, μ , is determined by the membership function. The degree of membership is defined over the interval from $[0,1]$ as:

$$\mu_{o_n} = a_n(e)$$

where a_n denotes the n th membership function such as "negative slow". A simple example of the fuzzification process is illustrated in FIG. 12. Triangular membership functions are used for this example because of their favorable properties. (See, for example, Liu, K. and Lewis, F. L., "Some Issues About Fuzzy Logic Control" Proceedings of the 32nd Conference on Decision and Control, December 1993, pp. 1743-1748.)

The next step in mapping the error signal to the control command is rule evaluation. The adopted sign convention and dynamical relationship between interacting error states and output controller commands are reflected in these rules. For each possible combination of membership classes (one from each universe of discourse), there is a rule defining which output membership function is activated. For two or more error states, the fuzzy control rules have the form:

$$\text{If } (e_1 \in a_{i,1}) \text{ and } (e_2 \in b_{i,2}) \text{ and } \dots \text{ Then } (u \in c_i)$$

where e_1 and e_2 are inputs to the controller, a, b, and c are linguistic or fuzzy labels, u is the output control and the subscript i denotes the rule number.

The final step is to defuzzify the aggregate of activated membership functions pertaining to the output control command. Given values for the error states in the evaluated rule, the degree to which u belongs to the output linguistic variable c_i is:

$$\omega_i = \min(\mu_{a_{i,1}}, \mu_{b_{i,2}}, \dots)$$

where ω_i is the degree of fulfillment of the rule. The most common method of determining the discrete output value for each control in the vector u is by calculating the centroid of where its membership function values are acting along the output control's universe of discourse. The output value is given by:

$$u = \frac{\sum_{i=1}^n \omega_i c_i}{\sum_{i=1}^n \omega_i}$$

where n is the number of rules.

Thus a crisp input value is mapped to a crisp output value through this three step process. It has been shown that any arbitrary mapping from an input to an output can take place if a nonlinear function (such as the minimum function) is used in the correlation process. (See, Rumelhart, D. E., McClelland, J. L., and PDP Research Group, Parallel Distributed Processing, Vol. 1: Foundations, MIT Press, Cambridge, Mass., 1986, pp. 318-362.)

A controller K defined by fuzzy logic is not dependent upon the last value of the provided command. If a single-input, single-output system is examined at a discrete time point, a linear control correlation between $e(k)$ and $u(k+1)$ can be obtained if the membership functions of the antecedents and the consequents are evenly spaced. However, the mapping can be made nonlinear by specifying either the antecedent or consequent spacing to be nonuniform as illustrated in FIG. 13. For a multiple input system, the mapping can be proven to always be nonlinear due to the nonlinear function required for the defuzzification process. The minimum function was used in this example.

The nonlinear attribute of the fuzzy logic controller allows the response shape to be tailored throughout the range of command levels. A response could be designed to be sluggish for low command/noise levels, conservative for nominal command levels, and exaggerated at high command levels (where efficient use of control is not the primary concern). The nonlinear feature also allows the capability to accommodate without limiting assumption system nonlinearities. Examples of nonlinearities pertinent to the presented example would be impulsive control and high angle of attack aerodynamics.

5.3(b) Example Application: Missile Autopilot

An example of an application is a missile with both aft fin control and forward propulsive control with an autopilot simultaneously utilizing and controlling both devices. (See also FIG. 1 and FIG. 11). The example vehicle is a supersonic, highly maneuverable missile having a length of thirteen feet, a diameter of one foot and a weight of three hundred pounds. (For a detailed development of the example vehicle system see, Schroeder, W. K., Parameter Estimation Using A Back Propagation Neural Network, Masters Thesis, University of Texas at Arlington, May, 1990). Control of the vehicle is achieved by actuator-driven aft movable fins and forward impulsive thrusters. The thrusters provide an impulsive force of 1000 pounds but are modeled with a linear force variation for this example. The center-of-gravity position is chosen to yield a stable vehicle and an adequate moment arm for both aft fin and forward thruster control implementations. The mechanisms were sized and placed to give approximately the same divert capability for a half second maneuver.

The summation of forces and moments for the symmetric, non-rolling vehicle propelled at a constant forward velocity provides the following state space equations of motion:

$$\begin{bmatrix} \dot{w} \\ \dot{q} \\ \dot{x} \\ \dot{\delta}_f \end{bmatrix} = \begin{bmatrix} Z_w & U_0 & 0 & Z_{\delta_f} \\ M_w & M_q & 0 & M_{\delta_f} \\ 0 & 0 & -2\zeta\omega_n^2 & -\omega_n^2 \\ 0 & 0 & 1 & 0 \end{bmatrix} \begin{bmatrix} w \\ q \\ x \\ \delta \end{bmatrix} + \begin{bmatrix} 0 & Z_{\delta_t} \\ 0 & M_{\delta_r} \\ \omega_n^2 & 0 \\ 0 & 0 \end{bmatrix} \begin{bmatrix} \delta_{t_c} \\ \delta_{r_c} \end{bmatrix}$$

$$\begin{bmatrix} N_z \\ \dot{\delta}_f \\ \dot{\delta}_t \end{bmatrix} = \begin{bmatrix} Z_w & 0 & 0 & Z_{\delta_f} \\ g & 1 & 0 & 0 \\ 0 & 0 & 0 & 1 \\ 0 & 0 & 0 & 0 \end{bmatrix} \begin{bmatrix} w \\ q \\ x \\ \delta \end{bmatrix} + \begin{bmatrix} 0 & Z_{\delta_t} \\ 0 & g \\ 0 & 0 \\ 0 & 1 \end{bmatrix} \begin{bmatrix} \delta_{t_c} \\ \delta_{r_c} \end{bmatrix}$$

where q is the pitch rate, w is the transverse velocity, and N_z is the transverse acceleration load factor. (See Table 1.) Fin and propulsive control commands are denoted by δ_{f_c} and δ_{r_c} respectively, whereas the actual increments of the respective control are given by δ_f and δ_r . Terms ω_n and ζ refer to the natural frequency and damping ratio of the second-order fin actuation system. See Table 2 for definitions and values of dimensionalized aerodynamic stability derivatives for a Mach 3.0 ($U_o=2985.3$ ft/s) fight.

TABLE 2

Time-Invariant Coefficients at Mach 3		
Coefficient	Value	Definition of Stability Derivative
M_w	-0.0244	$\partial(\text{pitching moment})/\partial(\text{transverse velocity})$
Z_w	-0.7858	$\partial(\text{normal force})/\partial(\text{transverse velocity})$
M_q	-0.6031	$\partial(\text{pitching moment})/\partial(\text{pitch rate})$
M_{δ_f}	-38.101	$\partial(\text{pitching moment})/\partial(\text{fin deflection})$
Z_{δ_f}	-1155.76	$\partial(\text{pitching force})/\partial(\text{fin deflection})$
M_{δ_r}	-29.929	$\partial(\text{pitching moment})/\partial(\text{thruster force})$
Z_{δ_r}	107.247	$\partial(\text{normal force})/\partial(\text{thruster force})$

The following relationships complete the connection to the block diagram previously provided in FIG. 11.

$$r = \begin{bmatrix} N_{z_{cmd}} \\ q_{trim} \end{bmatrix}, \quad u = \begin{bmatrix} \delta_{t_c} \\ \delta_{r_c} \end{bmatrix}, \quad y_c = \begin{bmatrix} N_z \\ q \end{bmatrix}$$

The error states (or antecedents) for the fuzzy logic controller are the difference between the desired load factor

and the measured N_z response and the difference between the trim pitch rate and the measured pitch rate. The trim value of the pitch rate can be implied from the N_z command level since the dynamics are so highly coupled. The antecedents are fed into separate membership functions for both the fins and the thrusters. The control vector elements of u (or consequents) are a combination of commands to the aft fins and forward thrusters.

An important incentive for simultaneously using both control mechanisms is an improvement in response time, and subsequent divert capability, a given missile configuration can achieve. The amount of transverse acceleration the missile must be capable of in an intercept endgame engagement is reduced by the improvement in response time squared. The controller response could be improved or degraded by simply altering its effective moment arm on the missile. This could be achieved by shifting the center-of-gravity which happens throughout the flight, or by moving the physical location of the control device. The longer the moment arm, the more rapid the control response. Due to physical constraints, the control mechanism locations are defined very early in the design process. Thus, the obvious remaining choice for increasing the moment applied to the vehicle is to use both control implementations simultaneously.

Dual-control is a difficult problem for conventional analysis techniques. Its multiple-input, multiple-output characteristics preclude single-input, single-output methods such as Bode, root locus, etc. Because these control mechanisms render the identical task (provide a moment to the vehicle), they are competitive. Therefore, a performance index is necessary to allocate the use of each device. The advantage fuzzy logic can provide through its designable nonlinear variation between u and e is the ability to address conflicting performance indices (however ambiguous). For example:

1. Aft fin control is relatively cheap.
2. Forward impulsive thruster control has severely limited endurance and therefore it expensive.
3. Acceleration response (N_z) is a premium.
4. Divert response (proportional to the double integral of N_z) is a premium.

Propulsive control is admirable in terms of response because it provides a control force in the direction of the maneuver as opposed to fin control which provides a control force in the opposite direction. However, the discrete nature of thrusters lend themselves to limit cycling. Therefore, at low command levels it is not desired to expend thrusters. Furthermore, when the error is nulled and the vehicle is in trim conditions, the steady state control should be provided by the fins.

The key to achieving the desired response goals and satisfying the above performance indices is in the shaping of the command controller signals based on the magnitude of the incoming acceleration command (i.e., the commanded dynamic response). The nonlinear controller variation used to achieve this is shown in FIG. 14. Note that since there is no control output for a zero error input for fuzzy logic control, a steady state error is required to hold trim. The control command is therefore scaled to provide 10 g's.

5.3(c) Analysis and Simulation Results

The maneuver goal is to reach a desired N_z command level in response to a step input. The desired level is set to 10 g's for the simulation analysis. The criterion of minimal overshoot is chosen for the purpose of comparing responses from the different controllers. This is equivalent to specifying a damping ratio around 0.9 for a second order linear system. The isolated control responses correspond to linear,

time-invariant constant gain feedback with the control rates and maximum commands identically bounded. Under these constraints, FIG. 15 shows the transverse acceleration load factor N_z response using a dual-control scheme in accordance with the invention 1500, conventional isolated thruster control 1505, and conventional isolated fin control 1510 mechanisms. It will be understood by those of ordinary skill in the field that a missile's divert capability is proportional to the double integral of the missile's transverse acceleration load factor. Thus, the dual-control strategy represented by curve 1500 has a larger magnitude divert capability than is possible with either a conventional isolated thruster or conventional isolated fin control technique.

5.4 Additional Enablement Methods

In addition to the fuzzy-logic embodiment described above, which uses a time domain description, the inventive control strategy can also be demonstrated using a frequency analysis technique known as H_∞ (H-infinity) control synthesis. As would be known to those of ordinary skill in the field, H_∞ analysis is a multiple-input, multiple-output, state-space control technique. A key to implementing the inventive control strategy using H_∞ techniques is the shaping of the control command signals in the frequency domain.

An H_∞ controller in accordance with the invention attenuates the use of fins in response to high frequency commanded accelerations, and attenuates the use of the forward thrusters in response to low frequency commanded accelerations. The selection of these specific attenuation frequencies will weight the use of the two control devices and is an iterative process culminating in the device usage defined by the invention.

The definition of high and low frequencies is a function of the missile's configuration, flight condition, and control authority. As a rough generalization, the beginning of the high frequency attenuation of the fins is an order of magnitude greater than the missile's natural frequency but below the frequency of the fin's actuating devices. The frequency below which the forward thruster usage is attenuated is typically on the same order of magnitude as the vehicle's natural frequency.

5.5 Advantages

It is a fundamental purpose of the instant invention to employ a dual-control mechanism that combines forward and aft control techniques cooperatively to dramatically improve the dynamic characteristics (maneuverability) of a missile. A control scheme in accordance with the invention provides the following advantages:

1. Increased missile maneuverability—measured by a missile's divert capability. The beneficial consequences of this advantage include:
 - a. Increased volume of defensible air space as defined by altitude and range coordinates (engagement envelope).
 - b. Increased capability against more maneuverable air vehicle threats.
 - c. Increased capability against air vehicle threats with small radar cross sections.
 - d. Decreased performance requirements on (expensive) sensor hardware for identical missile maneuverability as compared to missiles using conventional control strategies.
2. Increased control endurance and efficient use of control. A beneficial consequence of this advantage is the decreased missile weight/cost compared to missiles having identical maneuver capability using conventional control strategies. (Weight is proportional to cost.)

It will be appreciated by those of ordinary skill having the benefit of this disclosure that numerous variations from the foregoing illustration will be possible without departing from the inventive concept described herein. Accordingly, it is the claims set forth below, and not merely the foregoing illustration, which are intended to define the exclusive rights claimed in this application program.

What is claimed is:

1. A method for rapidly changing the direction of travel of a missile moving in a fluid medium to a desired new direction, said new direction being measured in the missile's inertial frame of reference, said missile having (i) a forward portion and a forward thruster control device and (ii) an aft portion and an aft fin control device, said method comprising:

(a) actuating (i) said forward thruster control device to generate a forward control force, acting on said forward portion, substantially in the desired new direction and (ii) said aft fin control device to generate an aft fin force, acting on said aft portion, substantially in the desired new direction;

(b) subsequently actuating said aft *fin* control device to generate an aft [control] *fin* force acting on said aft portion in a direction substantially opposite the direction of the aft control force in step (a).

2. A method for rapidly changing the direction of travel of a vehicle moving in a fluid medium to a desired new direction, said new direction being measured in the vehicle's inertial frame of reference, said vehicle having (i) a forward portion and a forward control device and (ii) an aft portion and an aft control device, said method comprising:

(a) actuating (i) said forward control device to generate a forward control force, acting on said forward portion, substantially in the desired new direction and (ii) said aft control device to generate an aft control force, acting on said aft portion, substantially in the desired new direction;

(b) subsequently actuating said aft control device to generate an aft control force acting on said aft portion in a direction substantially opposite the direction of the aft control force in step (a).

3. The method of claim 2, wherein said vehicle is a missile.

4. The method of claim 2, wherein said vehicle is a torpedo.

5. The method of claim 2, wherein said forward control device are thrusters.

6. The method of claim 2, wherein said forward control device are canards.

7. The method of claim 2, wherein said aft control device are fins.

8. The method of claim 2, wherein said aft control device are thrusters.

9. The method of claim 2, wherein said aft control device uses thrust vector control.

10. A control system for a vehicle having a forward portion referred to as a nose and an aft portion referred to as a tail, said system comprising:

(a) a controller configured to generate control signals;

(b) a nose-steering device controllable by the control signals;

(c) a tail-steering device controllable by the control signals;

(d) said controller being configured to cause the missile to change direction of travel by controlling the nose-steering device and the tail-steering device so that (1)

both the nose and the tail are initially pushed substantially toward a new direction of travel, after which (2) the tail is pushed substantially away from the new direction of travel.

11. The control system of claim 10, wherein the vehicle is a missile.

12. The control system of claim 10, wherein the nose-steering device comprises at least one thruster.

13. The control system of claim 10, wherein the tail-steering device comprises at least one fin.

14. A control system for a missile having a nose and a tail, said system comprising:

(a) an autopilot controller configured to generate control signals referred to as nose-control signals and tail-control signals respectively;

(b) a nose-steering device actuable in response to said nose control signals;

(c) one or more fins, referred to as tail fins, actuable in response to said tail control signals;

(d) said autopilot controller being configured:

(1) to generate one or more of said nose-control signals causing the nose-steering device to generate a force pushing the nose toward a new direction of travel; and

(2) to generate one or more of said tail-control signals that cause said one or more tail fins to generate forces that initially push the tail substantially toward the new direction of travel, then push the tail substantially away from the new direction of travel.

15. A method of maneuvering a vehicle, moving in a fluid medium, toward a direction of a commanded maneuver, said vehicle having:

(i) a forward portion and a forward control device, and

(ii) an aft portion and an aft control device, said method comprising:

actuating said forward control device to generate a forward control force, acting on said forward portion, said forward control force having a component acting in a direction that is substantially the same as the direction of the commanded maneuver; and

actuating said aft control device to generate a first aft control force, acting upon said aft portion, said first aft control force having a component acting in a direction that is substantially the same as the direction of the commanded maneuver;

wherein said forward control force is generated for a first period of time, wherein said first aft control force is generated for a second period of time, and wherein a major portion of said second period of time overlaps a major portion of said first period of time.

16. A method in accordance with claim 15, wherein said commanded maneuver is a maneuver requiring a change in transverse acceleration of the vehicle.

17. A method in accordance with claim 15, further comprising:

subsequent to the generation of the first aft control force, actuating said aft control device to generate a second aft control force acting on said aft portion, said second aft control force having a component acting in a direction that, relative to the aft portion, is substantially opposite to the direction of said component of said first aft force.

18. A method in accordance with claim 15, further comprising:

actuating, prior to the generation of the first aft control force, said aft control device to briefly generate a preliminary aft control force acting on said aft portion, said preliminary aft control force having a component acting in a direction that is substantially opposite to the direction of the commanded maneuver.

19. A method in accordance with claim 18, further comprising:

subsequent to the generation of the first aft control force, actuating said aft control device to generate a second aft control force acting on said aft portion, said second aft control force having a component acting in a direction that, relative to the aft portion, is substantially opposite to the direction of said component of said first aft force.

20. A method in accordance with claim 15, further comprising:

attenuating usage of the forward control device when the frequency of the commanded maneuver is low; and attenuating usage of the aft control device when the frequency of the commanded maneuver is high.

21. A method in accordance with claim 15, wherein a time of initiation of said first aft control force is substantially simultaneous with a time of initiation of said forward control force.

22. A method in accordance with claim 21, wherein a time of initiation of said first aft control force is simultaneous with a time of initiation of said forward control force.

23. A method in accordance with claim 15, wherein substantially all of said second period of time overlaps a portion of said first period of time.

24. A method for maneuvering a vehicle, moving in a fluid medium, toward a direction of a commanded maneuver, said vehicle having:

- (i) a forward portion and a forward control device and
- (ii) an aft portion and an aft control device, said method comprising:

actuating said forward control device to generate a forward control force, acting on said forward portion, said forward control force having a component acting in a direction that is substantially the same as the direction of the commanded maneuver; actuating said aft control device to generate a first aft control force, acting upon said aft portion, said first aft control force having a component acting in a direction that is substantially the same as the direction of the commanded maneuver;

wherein a time of initiation of said first aft control force is substantially simultaneous with a time of initiation of said forward control force.

25. A method in accordance with claim 24, wherein said commanded maneuver is a maneuver requiring a change in transverse acceleration of the vehicle.

26. A method in accordance with claim 24, further comprising:

subsequent to the generation of the first aft control force, actuating said aft control device to generate a second aft control force acting on said aft portion, said second aft control force having a component acting in a direction that, relative to the aft portion, is substantially opposite to the direction of said component of said first aft force.

27. A method in accordance with claim 24, further comprising:

actuating, prior to the generation of the first aft control force, said aft control device to briefly generate a

preliminary aft control force acting on said aft portion, said preliminary aft control force having a component acting in a direction that is substantially opposite to the direction of the commanded maneuver.

28. A method in accordance with claim 27, further comprising:

subsequent to the generation of the first aft control force, actuating said aft control device to generate a second aft control force acting on said aft portion, said second aft control force having a component acting in a direction that, relative to the aft portion, is substantially opposite to the direction of said component of said first aft force.

29. A method in accordance with claim 24, further comprising:

attenuating usage of the forward control device when the frequency of the commanded maneuver is low; and attenuating usage of the aft control device when the frequency of the commanded maneuver is high.

30. A control system for maneuvering a vehicle having a forward portion and an aft portion toward a direction of a commanded maneuver, said control system comprising:

- (a) a controller configured to generate control signals corresponding to the commanded maneuver;
- (b) a forward control device controllable by the control signals; and
- (c) an aft control device controllable by the control signals;
- (d) said controller configured to:

actuate said forward control device so as to generate a forward control force, acting on said forward portion, said forward control force having a component acting in a direction that is substantially the same as the direction of the commanded maneuver; actuate said aft control device so as to generate a first aft control force, acting on said aft portion, said first aft control force having a component acting in a direction that is substantially the same as the direction of the commanded maneuver;

wherein said forward control force is generated for a first period of time, wherein said first aft control force is generated for a second period of time, and wherein a major portion of said second period of time overlaps a major portion of said first period of time.

31. A control system in accordance with claim 30, wherein said commanded maneuver is a maneuver requiring a change in transverse acceleration of the vehicle.

32. A control system in accordance with claim 30, wherein the controller is further configured to:

subsequent to the generation of the first aft control force, actuating said aft control device to generate a second aft control force acting on said aft portion, said second aft control force having a component acting in a direction that, relative to the aft portion, is substantially opposite to the direction of said component of said first aft force.

33. A control system in accordance with claim 30, wherein the controller is further configured to:

actuate, prior to the generation of the first aft control force, said aft control device to briefly generate a preliminary aft control force acting on said aft portion, said preliminary aft control force having a component acting in a direction that is substantially opposite to the direction of the commanded maneuver.

34. A control system in accordance with claim 33, wherein the controller is further configured to:

subsequent to the generation of the first aft control force, actuate said aft control device to generate a second aft control force acting on said aft portion, said second aft control force having a component acting in a direction that, relative to the aft portion, is substantially opposite to the direction of said component of said first aft force.

35. A control system in accordance with claim 30, wherein the controller is further configured to:

attenuate usage of the forward control device when the frequency of the commanded maneuver is low; and attenuate usage of the aft control device when the frequency of the commanded maneuver is high.

36. A control system in accordance with claim 30, wherein a time of initiation of said first aft control force is substantially simultaneous with a time of initiation of said forward control force.

37. A control system in accordance with claim 36, wherein a time of initiation of said first aft control force is simultaneous with a time of initiation of said forward control force.

38. A control system in accordance with claim 30, wherein substantially all of said second period of time overlaps a portion of said first period of time.

39. A control system for maneuvering a vehicle having a forward portion and an aft portion toward a direction of a commanded maneuver, said control system comprising:

(a) a controller configured to generate control signals corresponding to the commanded maneuver;

(b) a forward control device controllable by the control signals; and

(c) an aft control device controllable by the control signals;

(d) said controller configured to:

actuate said forward control device so as to generate a forward control force, acting on said forward portion, said forward control force having a component acting in a direction that is substantially the same as the direction of the commanded maneuver; actuate said aft control device so as to generate a first aft control force, acting on said aft portion, said first aft control force having a component acting in a direction that is substantially the same as the direction of the commanded maneuver;

wherein a time of initiation of said first aft control force is substantially simultaneous with a time of initiation of said forward control force.

40. A control system in accordance with claim 39, wherein said commanded maneuver is a maneuver requiring a change in transverse acceleration of the vehicle.

41. A control system in accordance with claim 39, wherein the controller is further configured to:

subsequent to the generation of the first aft control force, actuate said aft control device to generate a second aft control force acting on said aft portion, said second aft control force having a component acting in a direction that, relative to the aft portion, is substantially opposite to the direction of said component of said first aft force.

42. A control system in accordance with claim 39, wherein the controller is further configured to:

actuate, prior to the generation of the first aft control force, said aft control device to briefly generate a preliminary aft control force acting on said aft portion, said preliminary aft control force having a component acting in a direction that is substantially opposite to the direction of the commanded maneuver.

43. A control system in accordance with claim 42, wherein the controller is further configured to:

subsequent to the generation of the first aft control force, actuate said aft control device to generate a second aft control force acting on said aft portion, said second aft control force having a component acting in a direction that, relative to the aft portion, is substantially opposite to the direction of said component of said first aft force.

44. A control system in accordance with claim 39, wherein the controller is further configured to:

attenuate usage of the forward control device when the frequency of the commanded maneuver is low; and attenuate usage of the aft control device when the frequency of the commanded maneuver is high.

45. A memory device for use with an autopilot controller for maneuvering a vehicle toward a direction of a commanded maneuver, said vehicle having:

(i) a forward portion,

(ii) an aft portion,

(iii) a forward steering device, and

(iv) an aft steering device,

said memory device encoding instructions executable by the autopilot controller to:

actuate said forward steering device to generate a forward control force, acting on said forward portion, said forward control force having a component acting in a direction that is substantially the same as the direction of the commanded maneuver; and

actuate said aft steering device to generate a first aft control force, acting upon said aft portion, said first aft control force having a component acting in a direction that is substantially the same as the direction of the commanded maneuver;

wherein said forward control force is generated for a first period of time, wherein said first aft control force is generated for a second period of time, and wherein a major portion of said second period of time overlaps a major portion of said first period of time.

46. A memory device in accordance with claim 45, wherein said commanded maneuver is a maneuver requiring a change in transverse acceleration of the vehicle.

47. A memory device in accordance with claim 45, wherein the memory device further encodes instructions executable by the autopilot controller to:

actuate, subsequent to the actuation of said aft steering device to generate the first aft control force, said aft steering device to generate a second aft control force acting on said aft portion, said second aft control force having a component acting in a direction that, relative to the aft portion, is substantially opposite to the direction of said component of said first aft force.

48. A memory device in accordance with claim 45, wherein the memory device further encodes instructions executable by the autopilot controller to:

actuate, prior to the actuation of said aft steering device to generate the first aft control force, said aft steering device to briefly generate a preliminary aft control force acting on said aft portion, said preliminary aft control force having a component acting in a direction that is substantially opposite to the direction of the commanded maneuver.

49. A memory device in accordance with claim 48, wherein the memory device further encodes instructions executable by the autopilot controller to:

actuate, subsequent to the actuation of said aft steering device to generate the first aft control force, said aft

21

steering device to generate a second aft control force acting on said aft portion, said second aft control force having a component acting in a direction that, relative to the aft portion, is substantially opposite to the direction of said component of said first aft force.

50. A memory device in accordance with claim 45, wherein the memory device further encodes instructions executable by the autopilot controller to:

attenuate usage of the forward steering device when the frequency of the commanded maneuver is low; and attenuate usage of the aft steering device when the frequency of the commanded maneuver is high.

51. A memory device in accordance with claim 45, wherein a time of initiation of said first aft control force is substantially simultaneous with a time of initiation of said forward control force.

52. A memory device in accordance with claim 51, wherein a time of initiation of said first aft control force is simultaneous with a time of initiation of said forward control force.

53. A memory device in accordance with claim 45, wherein substantially all of said second period of time overlaps a portion of said first period of time.

54. A memory device for use with an autopilot controller for maneuvering a vehicle toward a direction of a commanded maneuver, said vehicle having:

- (i) a forward portion,
- (ii) an aft portion,
- (iii) a forward steering device, and
- (iv) an aft steering device,

said memory device encoding instructions executable by the autopilot controller to:

actuate said forward steering device to generate a forward control force, acting on said forward portion, said forward control force having a component acting in a direction that is substantially the same as the direction of the commanded maneuver; and

actuate said aft steering device to generate a first aft control force, acting upon said aft portion, said first aft control force having a component acting in a direction that is substantially the same as the direction of the commanded maneuver;

wherein a time of initiation of said first aft control force is substantially simultaneous with a time of initiation of said forward control force.

55. A memory device in accordance with claim 54, wherein said commanded maneuver is a maneuver requiring a change in transverse acceleration of the vehicle.

56. A memory device in accordance with claim 54, wherein the memory device further encodes instructions executable by the autopilot controller to:

actuate, subsequent to the actuation of said aft steering device to generate the first aft control force, said aft steering device to generate a second aft control force acting on said aft portion, said second aft control force having a component acting in a direction that, relative to the aft portion, is substantially opposite to the direction of said component of said first aft force.

57. A memory device in accordance with claim 54, wherein the memory device further encodes instructions executable by the autopilot controller to:

actuate, prior to the actuation of said aft steering device to generate the first aft control force, said aft steering device to briefly generate a preliminary aft control force acting on said aft portion, said preliminary aft

22

control force having a component acting in a direction that is substantially opposite to the direction of the commanded maneuver.

58. A memory device in accordance with claim 57, wherein the memory device further encodes instructions executable by the autopilot controller to:

actuate, subsequent to the actuation of said aft steering device to generate the first aft control force, said aft steering device to generate a second aft control force acting on said aft portion, said second aft control force having a component acting in a direction that, relative to the aft portion, is substantially opposite to the direction of said component of said first aft force.

59. A memory device in accordance with claim 54, wherein the memory device further encodes instructions executable by the autopilot controller to:

attenuate usage of the forward steering device when the frequency of the commanded maneuver is low; and attenuate usage of the aft steering device when the frequency of the commanded maneuver is high.

60. A method for generating control signals suitable for maneuvering a vehicle toward a direction of a commanded maneuver, said vehicle having:

(i) a forward portion and a forward control device controllable by forward control signals, and

(ii) an aft portion and an aft control device controllable by aft control signals, said method comprising:

generating a forward control signal suitable for actuating said forward control device to generate a forward control force, acting on said forward portion, said forward control force having a component acting in a direction that is substantially the same as the direction of the commanded maneuver; and

generating an aft control signal suitable for actuating said aft control device to generate a first aft control force, acting upon said aft portion, said first aft control force having a component acting in a direction that is substantially the same as the direction of the commanded maneuver;

wherein said forward control force is generated for a first period of time, wherein said first aft control force is generated for a second period of time, and wherein a major portion of said second period of time overlaps a major portion of said first period of time.

61. A method in accordance with claim 60, wherein said commanded maneuver is a maneuver requiring a change in transverse acceleration of the vehicle.

62. A method in accordance with claim 60, further comprising:

subsequent to the generation of the aft control signal suitable for actuating said aft control device to generate said first aft control force, generating a second aft control signal suitable for actuating said aft control device to generate a second aft control force acting on said aft portion, said second aft control force having a component acting in a direction that, relative to the aft portion, is substantially opposite to the direction of said component of said first aft force.

63. A method in accordance with claim 60, further comprising:

generating, prior to the generation of the aft control signal suitable for actuating said aft control device to generate said first aft control force, a second aft control signal suitable for actuating said aft control device to briefly generate a preliminary aft control force acting

on said aft portion, said preliminary aft control force having a component acting in a direction that is substantially opposite to the direction of the commanded maneuver.

64. A method in accordance with claim 63, further comprising:

subsequent to the generation of the aft control signal suitable for actuating said aft control device to generate said first aft control force, generating a second aft control signal suitable for actuating said aft control device to generate a second aft control force acting on said aft portion, said second aft control force having a component acting in a direction that, relative to the aft portion, is substantially opposite to the direction of said component of said first aft force.

65. A method in accordance with claim 60, further comprising:

attenuating usage of the forward control device when the frequency of the commanded maneuver is low; and attenuating usage of the aft control device when the frequency of the commanded maneuver is high.

66. A method in accordance with claim 60, wherein a time of initiation of said first aft control force is substantially simultaneous with a time of initiation of said forward control force.

67. A method in accordance with claim 66, wherein a time of initiation of said first aft control force is simultaneous with a time of initiation of said forward control force.

68. A method in accordance with claim 60, wherein substantially all of said second period of time overlaps a portion of said first period of time.

69. A method for generating control signals suitable for maneuvering a vehicle toward a direction of a commanded maneuver, said vehicle having:

(i) a forward portion and a forward control device controllable by forward control signals, and

(ii) an aft portion and an aft control device controllable by aft control signals, said method comprising:

generating a forward control signal suitable for actuating said forward control device to generate a forward control force, acting on said forward portion, said forward control force having a component acting in a direction that is substantially the same as the direction of the commanded maneuver; and

generating an aft control signal suitable for actuating said aft control device to generate a first aft control force, acting upon said aft portion, said first aft control force having a component acting in a direction that is substantially the same as the direction of the commanded maneuver;

wherein a time of initiation of said first aft control force is substantially simultaneous with a time of initiation of said forward control force.

70. A method in accordance with claim 69, wherein said commanded maneuver is a maneuver requiring a change in transverse acceleration of the vehicle.

71. A method in accordance with claim 69, further comprising:

subsequent to the generation of the aft control signal suitable for actuating said aft control device to generate said first aft control force, generating a second aft control signal suitable for actuating said aft control device to generate a second aft control force acting on said aft portion, said second aft control force having a component acting in a direction that, relative to the aft

portion, is substantially opposite to the direction of said component of said first aft force.

72. A method in accordance with claim 69, further comprising:

generating, prior to the generation of the aft control signal suitable for actuating said aft control device to generate said first aft control force, a second aft control signal suitable for actuating said aft control device to briefly generate a preliminary aft control force acting on said aft portion, said preliminary aft control force having a component acting in a direction that is substantially opposite to the direction of the commanded maneuver.

73. A method in accordance with claim 72, further comprising:

subsequent to the generation of the aft control signal suitable for actuating said aft control device to generate said first aft control force, generating a second aft control signal suitable for actuating said aft control device to generate a second aft control force acting on said aft portion, said second aft control force having a component acting in a direction that, relative to the aft portion, is substantially opposite to the direction of said component of said first aft force.

74. A method in accordance with claim 69, further comprising:

attenuating usage of the forward control device when the frequency of the commanded maneuver is low; and

attenuating usage of the aft control device when the frequency of the commanded maneuver is high.

75. An autopilot controller for generating control signals suitable for maneuvering a vehicle toward a direction of a commanded maneuver, said vehicle having:

(i) a forward portion,

(ii) an aft portion,

(iii) a forward steering device actuatable in response to forward control signals, and

(iv) an aft steering device actuatable in response to aft control signals,

said autopilot controller comprising:

(a) means for generating a forward control signal suitable for actuating said forward steering device to generate a forward control force, acting on said forward portion, said forward control force having a component acting in a direction that is substantially the same as the direction of the commanded maneuver; and

(b) means for generating an aft control signal suitable for actuating said aft steering device to generate a first aft control force, acting on said aft portion, said first aft control force having a component acting in a direction that is substantially the same as the direction of the commanded maneuver;

wherein said forward control force is generated for a first period of time, wherein said first aft control force is generated for a second period of time, and wherein a major portion of said second period of time overlaps a major portion of said first period of time.

76. An autopilot controller in accordance with claim 75, wherein said commanded maneuver is a maneuver requiring a change in transverse acceleration of the vehicle.

77. An autopilot controller in accordance with claim 75, further comprising:

means for generating, subsequent to the generation of the aft control signal suitable for actuating said aft control

device to generate said first aft control force, a second aft control signal suitable for actuating said aft control device to generate a second aft control force acting on said aft portion, said second aft control force having a component acting in a direction that, relative to the aft portion, is substantially opposite to the direction of said component of said first aft force.

78. An autopilot controller in accordance with claim 75, further comprising:

means for generating, prior to the generation of the aft control signal suitable for actuating said aft control device to generate said first aft control force, a second aft control signal suitable for actuating said aft control device to briefly generate a preliminary aft control force acting on said aft portion, said preliminary aft control force having a component acting in a direction that is substantially opposite to the direction of the commanded maneuver.

79. An autopilot controller in accordance with claim 78, further comprising:

means for generating, subsequent to the generation of the aft control signal suitable for actuating said aft control device to generate said first aft control force, a second aft control signal suitable for actuating said aft control device to generate a second aft control force acting on said aft portion, said second aft control force having a component acting in a direction that, relative to the aft portion, is substantially opposite to the direction of said component of said first aft force.

80. An autopilot controller in accordance with claim 75, further comprising:

means for attenuating usage of the forward control device when the frequency of the commanded maneuver is low; and

means for attenuating usage of the aft control device when the frequency of the commanded maneuver is high.

81. An autopilot controller in accordance with claim 75, wherein a time of initiation of said first aft control force is substantially simultaneous with a time of initiation of said forward control force.

82. An autopilot controller in accordance with claim 81, wherein a time of initiation of said first aft control force is simultaneous with a time of initiation of said forward control force.

83. An autopilot controller in accordance with claim 75, wherein substantially all of said second period of time overlaps a portion of said first period of time.

84. An autopilot controller for generating control signals suitable for maneuvering a vehicle toward a direction of a commanded maneuver, said vehicle having:

- (i) a forward portion,
- (ii) an aft portion,
- (iii) a forward steering device actuatable in response to forward control signals, and
- (iv) an aft steering device actuatable in response to aft control signals, said autopilot controller comprising:

(a) means for generating a forward control signal suitable for actuating said forward steering device to generate a forward control force, acting on said forward portion, said forward control force having a component acting in a direction that is substantially the same as the direction of the commanded maneuver; and

(b) means for generating an aft control signal suitable for actuating said aft steering device to generate a first aft control force, acting on said aft portion, said

first aft control force having a component acting in a direction that is substantially the same as the direction of the commanded maneuver; wherein a time of initiation of said first aft control force is substantially simultaneous with a time of initiation of said forward control force.

85. An autopilot controller in accordance with claim 84, wherein said commanded maneuver is a maneuver requiring a change in transverse acceleration of the vehicle.

86. An autopilot controller in accordance with claim 84, further comprising:

means for generating, subsequent to the generation of the aft control signal suitable for actuating said aft control device to generate said first aft control force, a second aft control signal suitable for actuating said aft control device to generate a second aft control force acting on said aft portion, said second aft control force having a component acting in a direction that, relative to the aft portion, is substantially opposite to the direction of said component of said first aft force.

87. An autopilot controller in accordance with claim 84, further comprising:

means for generating, prior to the generation of the aft control signal suitable for actuating said aft control device to generate said first aft control force, a second aft control signal suitable for actuating said aft control device to briefly generate a preliminary aft control force acting on said aft portion, said preliminary aft control force having a component acting in a direction that is substantially opposite to the direction of the commanded maneuver.

88. An autopilot controller in accordance with claim 87, further comprising:

means for generating, subsequent to the generation of the aft control signal suitable for actuating said aft control device to generate said first aft control force, a second aft control signal suitable for actuating said aft control device to generate a second aft control force acting on said aft portion, said second aft control force having a component acting in a direction that, relative to the aft portion, is substantially opposite to the direction of said component of said first aft force.

89. An autopilot controller in accordance with claim 84, further comprising:

means for attenuating usage of the forward control device when the frequency of the commanded maneuver is low; and

means for attenuating usage of the aft control device when the frequency of the commanded maneuver is high.

90. A memory device for generating control signals suitable for use with an autopilot controller for maneuvering a vehicle toward a direction of a commanded maneuver, said vehicle having

- (i) a forward portion,
- (ii) an aft portion,
- (iii) a forward steering device actuatable in response to forward control signals, and
- (iv) an aft steering device actuatable in response to aft control signals,

said memory device encoding instructions executable by the autopilot controller to:

generate a forward control signal suitable for actuating said forward steering device so as to generate a forward control force, acting on said forward portion, said forward control force having a compo-

nent acting in a direction that is substantially the same as the direction of the commanded maneuver; and

generate an aft control signal suitable for actuating said aft control device so as to generate a first aft control force, acting upon said aft portion, said first aft control force having a component acting in a direction that is substantially the same as the direction of the commanded maneuver;

wherein said forward control force is generated for a first period of time, wherein said first aft control force is generated for a second period of time, and wherein a major portion of said second period of time overlaps a major portion of said first period of time.

91. A memory device in accordance with claim 90, wherein said commanded maneuver is a maneuver requiring a change in transverse acceleration of the vehicle.

92. A memory device in accordance with claim 90, wherein the memory device further encodes instructions executable by the autopilot controller to:

generate, subsequent to the generation of said aft control signal suitable for actuating said aft steering device so as to generate said first aft control force, an aft control signal suitable for actuating said aft steering device to generate a second aft control force acting on said aft portion, said second aft control force having a component acting in a direction that, relative to the aft portion, is substantially opposite to the direction of said component of said first aft force.

93. A memory device in accordance with claim 90, wherein the memory device further encodes instructions executable by the autopilot controller to:

generate, prior to the generation of said aft control signal suitable for actuating said aft steering device so as to generate said first aft control force, an aft control signal suitable for actuating said aft steering device to briefly generate a preliminary aft control force acting on said aft portion, said preliminary aft control force having a component acting in a direction that is substantially opposite to the direction of the commanded maneuver.

94. A memory device in accordance with claim 93, wherein the memory device further encodes instructions executable by the autopilot controller to:

generate, subsequent to the generation of said aft control signal suitable for actuating said aft steering device so as to generate said first aft control force, an aft control signal suitable for actuating said aft steering device to generate a second aft control force acting on said aft portion, said second aft control force having a component acting in a direction that, relative to the aft portion, is substantially opposite to the direction of said component of said first aft force.

95. A memory device in accordance with claim 90, wherein the memory device further encodes instructions executable by the autopilot controller to:

attenuate usage of the forward steering device when the frequency of the commanded maneuver is low; and attenuate usage of the aft steering device when the frequency of the commanded maneuver is high.

96. A memory device in accordance with claim 90, wherein a time of initiation of said first aft control force is substantially simultaneous with a time of initiation of said forward control force.

97. A memory device in accordance with claim 96, wherein a time of initiation of said first aft control force is simultaneous with a time of initiation of said forward control force.

98. A memory device in accordance with claim 90, wherein substantially all of said second period of time overlaps a portion of said first period of time.

99. A memory device for generating control signals suitable for use with an autopilot controller for maneuvering a vehicle toward a direction of a commanded maneuver, said vehicle having

(i) a forward portion,

(ii) an aft portion,

(iii) a forward steering device actuatable in response to forward control signals, and

(iv) an aft steering device actuatable in response to aft control signals,

said memory device encoding instructions executable by the autopilot controller to:

generate a forward control signal suitable for actuating said forward steering device so as to generate a forward control force, acting on said forward portion, said forward control force having a component acting in a direction that is substantially the same as the direction of the commanded maneuver; and

generate an aft control signal suitable for actuating said aft control device so as to generate a first aft control force, acting upon said aft portion, said first aft control force having a component acting in a direction that is substantially the same as the direction of the commanded maneuver;

wherein a time of initiation of said first aft control force is substantially simultaneous with a time of initiation of said forward control force.

100. A memory device in accordance with claim 99, wherein said commanded maneuver is a maneuver requiring a change in transverse acceleration of the vehicle.

101. A memory device in accordance with claim 99, wherein the memory device further encodes instructions executable by the autopilot controller to:

generate, subsequent to the generation of said aft control signal suitable for actuating said aft steering device so as to generate said first aft control force, an aft control signal suitable for actuating said aft steering device to generate a second aft control force acting on said aft portion, said second aft control force having a component acting in a direction that, relative to the aft portion, is substantially opposite to the direction of said component of said first aft force.

102. A memory device in accordance with claim 99, wherein the memory device further encodes instructions executable by the autopilot controller to:

generate, prior to the generation of said aft control signal suitable for actuating said aft steering device so as to generate said first aft control force, an aft control signal suitable for actuating said aft steering device to briefly generate a preliminary aft control force acting on said aft portion, said preliminary aft control force having a component acting in a direction that is substantially opposite to the direction of the commanded maneuver.

103. A memory device in accordance with claim 102, wherein the memory device further encodes instructions executable by the autopilot controller to:

generate, subsequent to the generation of said aft control signal suitable for actuating said aft steering device so as to generate said first aft control force, an aft control signal suitable for actuating said aft steering device to generate a second aft control force acting on said aft

portion, said second aft control force having a component acting in a direction that, relative to the aft portion, is substantially opposite to the direction of said component of said first aft force.

104. A memory device in accordance with claim 99, wherein the memory device further encodes instructions executable by the autopilot controller to:

attenuate usage of the forward steering device when the frequency of the commanded maneuver is low; and attenuate usage of the aft steering device when the frequency of the commanded maneuver is high.

105. A method for maneuvering a vehicle, moving in a fluid medium, toward a direction of a commanded maneuver, said vehicle having:

- (i) a forward portion and a forward control device, and
- (ii) an aft portion and an aft control device, said method comprising:

actuating said forward control device to generate a forward control force, acting on said forward portion, said forward control force having a component acting in a direction that is substantially the same as the direction of the commanded maneuver; and

actuating said aft control device to generate a first aft control force, acting upon said aft portion, said first aft control force having a component acting in a direction that is substantially the same as the direction of the commanded maneuver;

wherein said first aft control force and said forward control force are generated in response to the commanded maneuver so as to obtain a divert capability for the vehicle that is greater than a divert capability for the vehicle which is obtainable for an identical commanded maneuver for the vehicle using (a) only a forward control force, (b) only an aft control force, or (c) a forward control force and an aft control force in an intuitive control scheme.

106. A method in accordance with claim 105, wherein said commanded maneuver is a maneuver requiring a change in transverse acceleration of the vehicle.

107. A method in accordance with claim 105, further comprising:

subsequent to the generation of the first aft control force, actuating said aft control device to generate a second aft control force acting on said aft portion, said second aft control force having a component acting in a direction that, relative to the aft portion, is substantially opposite to the direction of said component of said first aft force.

108. A method in accordance with claim 105, further comprising:

actuating, prior to the generation of the first aft control force, said aft control device to briefly generate a preliminary aft control force acting on said aft portion, said preliminary aft control force having a component acting in a direction that is substantially opposite to the direction of the commanded maneuver.

109. A method in accordance with claim 108, further comprising:

subsequent to the generation of the first aft control force, actuating said aft control device to generate a second aft control force acting on said aft portion, said second aft control force having a component acting in a direction that, relative to the aft portion, is substantially opposite to the direction of said component of said first aft force.

110. A method in accordance with claim 105, further comprising:

attenuating usage of the forward control device when the frequency of the commanded maneuver is low; and attenuating usage of the aft control device when the frequency of the commanded maneuver is high.

111. A method in accordance with claim 105, wherein a time of initiation of said first aft control force is substantially simultaneous with a time of initiation of said forward control force.

112. A method in accordance with claim 111, wherein a time of initiation of said first aft control force is simultaneous with a time of initiation of said forward control force.

113. A method in accordance with claim 105, wherein said first aft control force is generated for a first period of time, wherein said forward control force is generated for a second period of time, and wherein a major portion of said first period of time overlaps a major portion of said second period of time.

114. A control system for maneuvering a vehicle having a forward portion and an aft portion toward a direction of a commanded maneuver, said control system comprising:

- (a) a controller configured to generate control signals corresponding to the commanded maneuver;
 - (b) a forward control device controllable by the control signals; and
 - (c) an aft control device controllable by the control signals;
- (d) said controller configured to:

actuate said forward control device so as to generate a forward control force, acting on said forward portion, said forward control force having a component acting in a direction that is substantially the same as the direction of the commanded maneuver; actuate said aft control device so as to generate a first aft control force, acting on said aft portion, said first aft control force having a component acting in a direction that is substantially the same as the direction of the commanded maneuver;

wherein said first aft control force and said forward control force are generated in response to the commanded maneuver so as to obtain a divert capability for the vehicle that is greater than a divert capability for the vehicle which is obtainable for an identical commanded maneuver for the vehicle using (a) only a forward control force, (b) only an aft control force, or (c) a forward control force and an aft control force in an intuitive control scheme.

115. A control system in accordance with claim 114, wherein said commanded maneuver is a maneuver requiring a change in transverse acceleration of the vehicle.

116. A control system in accordance with claim 114, wherein the controller is further configured to:

subsequent to the generation of the first aft control force, actuate said aft control device to generate a second aft control force acting on said aft portion, said second aft control force having a component acting in a direction that, relative to the aft portion, is substantially opposite to the direction of said component of said first aft force.

117. A control system in accordance with claim 114, wherein the controller is further configured to:

actuate, prior to the generation of the first aft control force, said aft control device to briefly generate a preliminary aft control force acting on said aft portion, said preliminary aft control force having a component acting in a direction that is substantially opposite to the direction of the commanded maneuver.

118. A control system in accordance with claim 117, wherein the controller is further configured to:

subsequent to the generation of the first aft control force, actuate said aft control device to generate a second aft control force acting on said aft portion, said second aft control force having a component acting in a direction that, relative to the aft portion, is substantially opposite to the direction of said component of said first aft force.

119. A control system in accordance with claim 114, wherein the controller is further configured to:

attenuate usage of the forward control device when the frequency of the commanded maneuver is low; and attenuate usage of the aft control device when the frequency of the commanded maneuver is high.

120. A control system in accordance with claim 114, wherein a time of initiation of said first aft control force is substantially simultaneous with a time of initiation of said forward control force.

121. A control system in accordance with claim 120, wherein a time of initiation of said first aft control force is simultaneous with a time of initiation of said forward control force.

122. A control system in accordance with claim 114, wherein said first aft control force is generated for a first period of time, wherein said forward control force is generated for a second period of time, and wherein a major portion of said first period of time overlaps a major portion of said second period of time.

123. A method for maneuvering a vehicle, moving in a fluid medium, toward a direction of a commanded maneuver, said vehicle having:

- (i) a forward portion and a forward control device, and
- (ii) an aft portion and an aft control device, said method comprising:

actuating said forward control device to generate a forward control force, acting on said forward portion, said forward control force having a component acting in a direction that is substantially the same as the direction of the commanded maneuver; and

actuating said aft control device to generate a first aft control force, acting upon said aft portion, said first aft control force having a component acting in a direction that is substantially the same as the direction of the commanded maneuver;

wherein, for a period of time of 0.1 second beginning with an initiation of said step of actuating said forward control device to generate a forward control force, a major portion of a cumulative effect of said first aft control force acts in a direction that, with respect to the aft portion, is substantially the same as the direction of the commanded maneuver.

124. A method in accordance with claim 123, wherein said commanded maneuver is a maneuver requiring a change in transverse acceleration of the vehicle.

125. A method in accordance with claim 123, further comprising:

subsequent to the generation of the first aft control force, actuating said aft control device to generate a second aft control force acting on said aft portion, said second aft control force having a component acting in a direction that, relative to the aft portion, is substantially opposite to the direction of said component of said first aft force.

126. A method in accordance with claim 123, further comprising:

actuating, prior to the generation of the first aft control force, said aft control device to briefly generate a preliminary aft control force acting on said aft portion, said preliminary aft control force having a component acting in a direction that is substantially opposite to the direction of the commanded maneuver.

127. A method in accordance with claim 126, further comprising:

subsequent to the generation of the first aft control force, actuating said aft control device to generate a second aft control force acting on said aft portion, said second aft control force having a component acting in a direction that, relative to the aft portion, is substantially opposite to the direction of said component of said first aft force.

128. A method in accordance with claim 123, further comprising:

attenuating usage of the forward control device when the frequency of the commanded maneuver is low; and attenuating usage of the aft control device when the frequency of the commanded maneuver is high.

129. A method in accordance with claim 123, wherein a time of initiation of said first aft control force is substantially simultaneous with a time of initiation of said forward control force.

130. A method in accordance with claim 129, wherein a time of initiation of said first aft control force is simultaneous with a time of initiation of said forward control force.

131. A method in accordance with claim 123, wherein said first aft control force is generated for a first period of time, wherein said forward control force is generated for a second period of time, and wherein a major portion of said first period of time overlaps a major portion of said second period of time.

132. A control system for maneuvering a vehicle having a forward portion and an aft portion toward a direction of a commanded maneuver, said control system comprising:

- (a) a controller configured to generate control signals corresponding to the commanded maneuver;
- (b) a forward control device controllable by the control signals; and
- (c) an aft control device controllable by the control signals;
- (d) said controller configured to:

actuate said forward control device so as to generate a forward control force, acting on said forward portion, said forward control force having a component acting in a direction that is substantially the same as the direction of the commanded maneuver; actuate said aft control device so as to generate a first aft control force, acting on said aft portion, said first aft control force having a component acting in a direction that is substantially the same as the direction of the commanded maneuver;

wherein, for a period of time of 0.1 second beginning with an initiation of said actuation of said forward control device to generate a forward control force, a major portion of a cumulative effect of said first aft control force acts in a direction that, with respect to the aft portion, is substantially the same as the direction of the commanded maneuver.

133. A control system in accordance with claim 132, wherein said commanded maneuver is a maneuver requiring a change in transverse acceleration of the vehicle.

134. A control system in accordance with claim 132, wherein the controller is further configured to:

subsequent to the generation of the first aft control force, actuate said aft control device to generate a second aft control force acting on said aft portion, said second aft control force having a component acting in a direction that, relative to the aft portion, is substantially opposite to the direction of said component of said first aft force. 5

135. A control system in accordance with claim 132, wherein the controller is further configured to:

actuate, prior to the generation of the first aft control force, said aft control device to briefly generate a preliminary aft control force acting on said aft portion, said preliminary aft control force having a component acting in a direction that is substantially opposite to the direction of the commanded maneuver. 10

136. A control system in accordance with claim 135, wherein the controller is further configured to: 15

subsequent to the generation of the first aft control force, actuate said aft control device to generate a second aft control force acting on said aft portion, said second aft control force having a component acting in a direction that, relative to the aft portion, is substantially opposite to the direction of said component of said first aft force. 20

137. A control system in accordance with claim 132, wherein the controller is further configured to:

attenuate usage of the forward control device when the frequency of the commanded maneuver is low; and attenuate usage of the aft control device when the frequency of the commanded maneuver is high.

138. A control system in accordance with claim 132, wherein a time of initiation of said first aft control force is substantially simultaneous with a time of initiation of said forward control force.

139. A control system in accordance with claim 138, wherein a time of initiation of said first aft control force is simultaneous with a time of initiation of said forward control force.

140. A control system in accordance with claim 132, wherein said first aft control force is generated for a first period of time, wherein said forward control force is generated for a second period of time, and wherein a major portion of said first period of time overlaps a major portion of said second period of time.

* * * * *

UNITED STATES PATENT AND TRADEMARK OFFICE
CERTIFICATE OF CORRECTION

PATENT NO. : Re 37, 331 P2
DATED : August 14, 2001
INVENTOR(S) : Wayne K. Schroeder

Page 1 of 1

It is certified that error appears in the above-identified patent and that said Letters Patent is hereby corrected as shown below:

Title page,

ABSTRACT

Line 10, after "maneuver)", delete "which", and insert -- while --.

Column 1,

Line 46, delete "controls", and insert -- control --.

Column 2,

Line 17, after "applying", insert -- a moment --.

Column 4,

Lines 60 and 61, delete "directions", and insert -- direction --.

Column 13,

Line 38, delete "it", and insert -- is --.

Column 16,

Line 31, after "method", delete "of", and insert -- for --.

Column 18,

Line 52, delete "actuating", and insert -- actuate --.

Signed and Sealed this

Fifth Day of March, 2002

Attest:



Attesting Officer

JAMES E. ROGAN
Director of the United States Patent and Trademark Office

UNITED STATES PATENT AND TRADEMARK OFFICE
CERTIFICATE OF CORRECTION

PATENT NO. : RE 37,331 E
DATED : August 14, 2001
INVENTOR(S) : Wayne K. Schroeder

Page 1 of 1

It is certified that error appears in the above-identified patent and that said Letters Patent is hereby corrected as shown below:

Title page,

ABSTRACT,

Line 10, after “maneuver)”, delete “which”, and insert -- while --.

Column 1,

Line 46, delete “controls”, and insert -- control --.

Column 2,

Line 17, after “applying”, insert -- a moment --.

Column 4,

Lines 60 and 61, delete “directions”, and insert -- direction --.

Column 13,

Line 38, delete “it”, and insert -- is --.

Column 16,

Line 31, after “*method*”, delete “*of*”, and insert -- *for* --.

Column 18,

Line 52, delete “*actuating*”, and insert -- *actuate* --.

This certificate supersedes Certificate of Correction issued March 5, 2002.

Signed and Sealed this

Twenty-fifth Day of June, 2002

Attest:



Attesting Officer

JAMES E. ROGAN
Director of the United States Patent and Trademark Office