

T. CARROLL.
CASH REGISTER AND INDICATOR.

No. 521,334.

Patented June 12, 1894.

Fig. 1

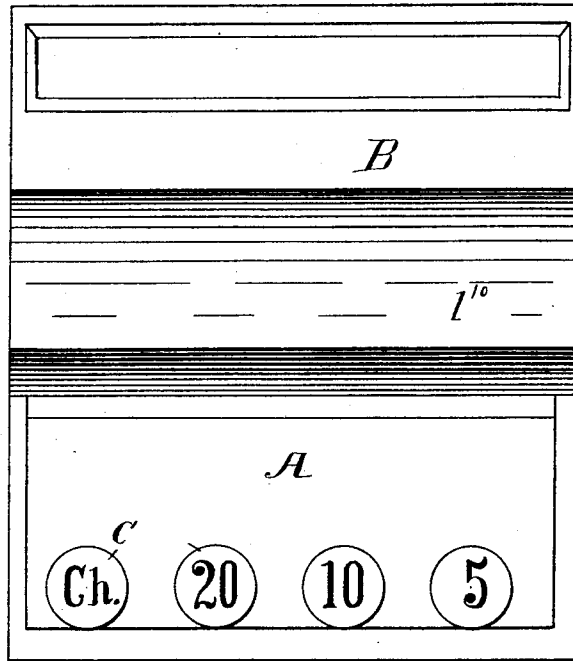
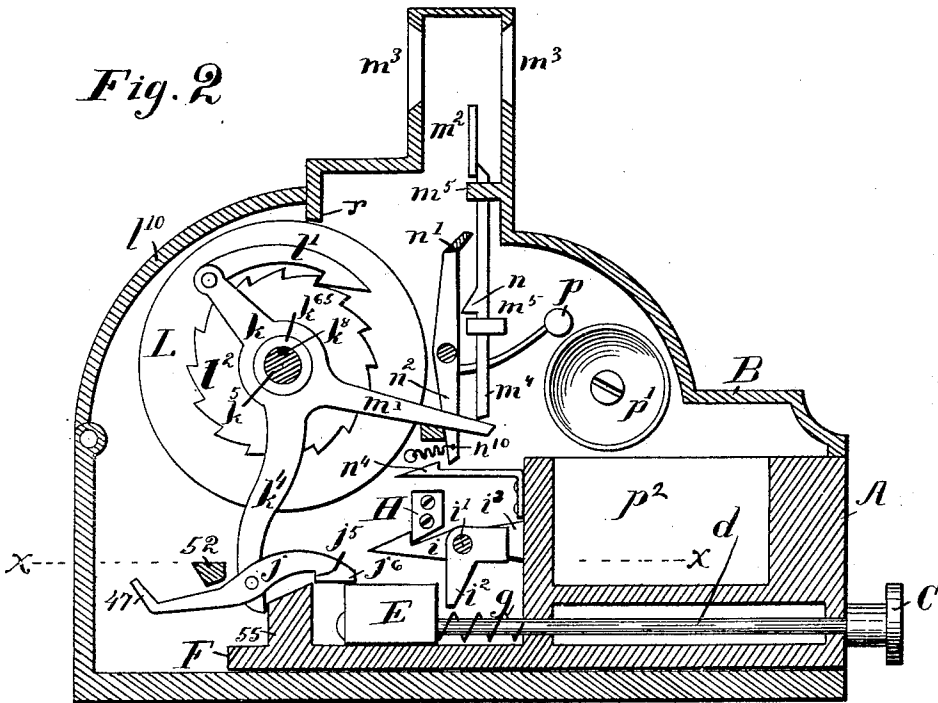

Fig. 2



Witnesses
Linus Barnes
Phillie Barnes

Inventor
Thomas Carroll

By George L. Barnes Attorney

T. CARROLL.
CASH REGISTER AND INDICATOR.

No. 521,334.

Patented June 12, 1894.

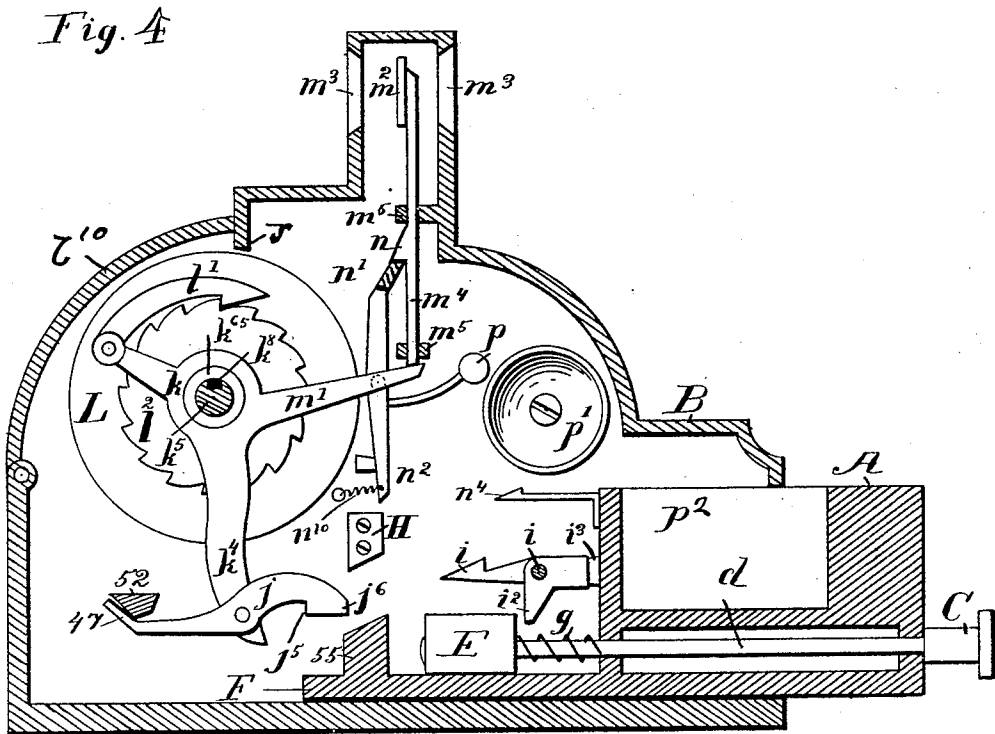
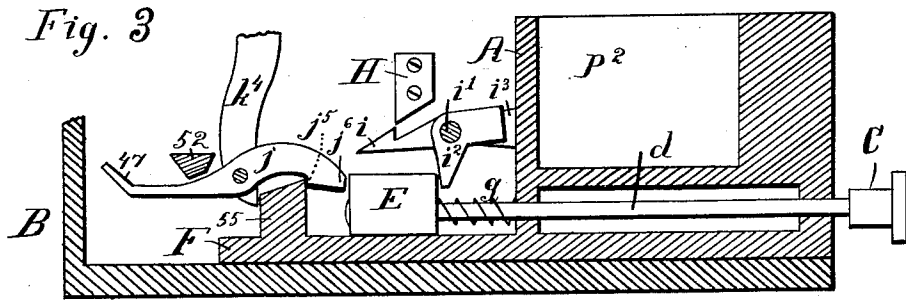

Witnesses
Linus Barnes
Phillip Barnes

Inventor
Thomas Carroll

By *George L. Barnes* Attorney

T. CARROLL.
CASH REGISTER AND INDICATOR.

No. 521,334.

Patented June 12, 1894.

Fig. 5

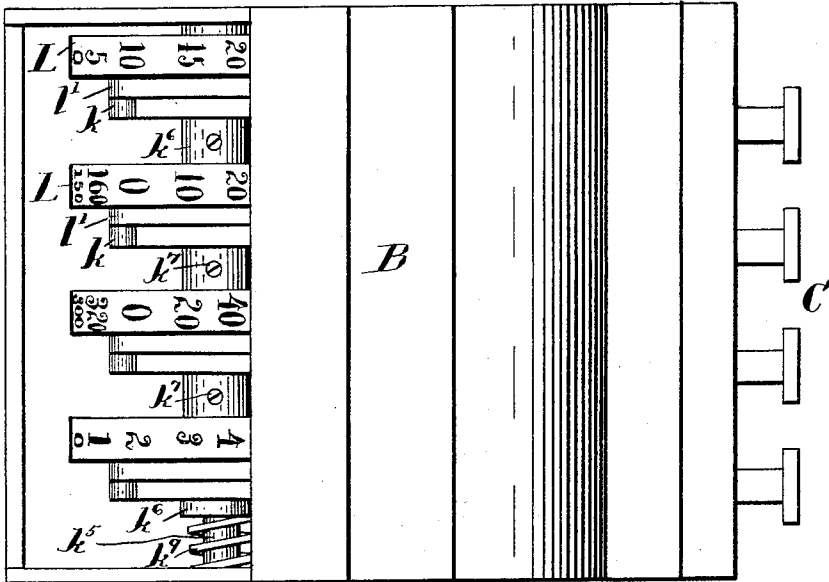
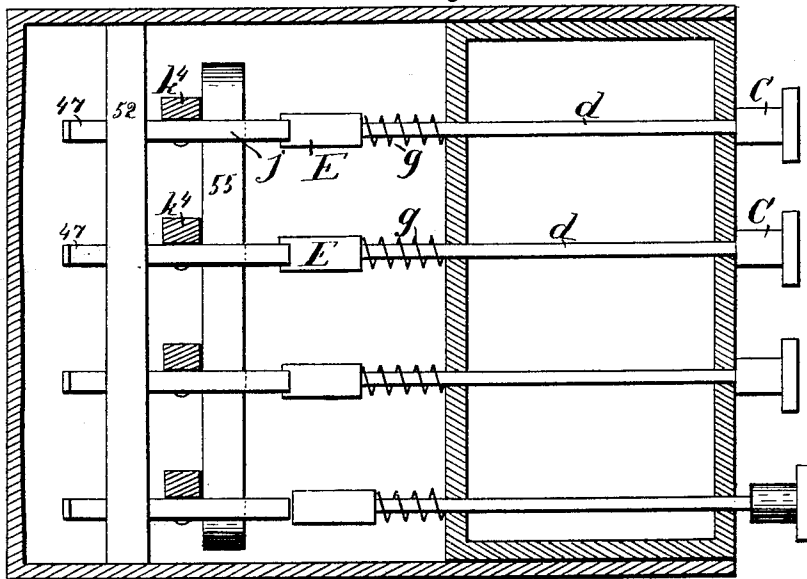

Fig. 6



Witnesses
Linn B. Barnes
Hills Barnes

Inventor
Thomas Carroll

By George L. Barnes Attorney

UNITED STATES PATENT OFFICE.

THOMAS CARROLL, OF NEW HAVEN, CONNECTICUT, ASSIGNOR TO THE HUBINGER CARROLL CASH REGISTER COMPANY, OF SAME PLACE.

CASH REGISTER AND INDICATOR.

SPECIFICATION forming part of Letters Patent No. 521,334, dated June 12, 1894.

Application filed October 6, 1893. Serial No. 487,402. (No model.)

To all whom it may concern:

Be it known that I, THOMAS CARROLL, a citizen of the United States, residing at New Haven, in the county of New Haven and State of Connecticut, have invented certain new and useful Improvements in Cash Registers and Indicators, of which the following is a specification.

My invention relates to an improvement in that class of cash registers and indicators in which the simple operation of drawing open the cash drawer by means of a knob or drawer pull or combination of knobs or drawer pulls representing different values and having operating rods and connections individually guided and adapted to a limited independent movement in the drawer, is adapted to accomplish the announcement, indication and registration of sales, the operation of the registering and indicating mechanism being effected by corresponding motive devices carried by the drawer, subject to control by the initial action of the drawer pulls, which action also is adapted to release the locking mechanism of the drawer. The number, combination, and values of the drawer pulls may vary indefinitely in this class of register, according to the requirements of different machines, each knob however having its own registering, indicating, and drawer releasing mechanism and motive devices.

The invention involves certain improvements in the invention for which Letters Patent of the United States, No. 499,192, were granted to Thomas Carroll under date of June 6, 1893, and it consists in the novel motive devices for actuating the registering mechanism, and in the improved tripping and restoring mechanism of the device, and construction of parts as hereinafter more fully described and claimed.

In the accompanying drawings forming a part of this specification, Figure 1 is a front elevation of a small sized cash register and indicator embodying present improvements, and having four knobs adapted respectively for registering "No sale" or "Change" and 5 cents, 10 cents, and 20 cents, and also amounts which are sums of those numbers, by the manipulation of combinations of the knobs, such register being adapted for use in

connection with a soda fountain or cigar stand. Fig. 2 is a vertical cross section through Fig. 1 showing the cash drawer closed and locked. Fig. 3 is a cross sectional view similar to Fig. 2, but showing the cash drawer unlocked, and the motive devices engaged to operate the registering and indicating mechanism. Fig. 4 is a similar cross sectional view but showing the cash drawer partly opened, the registering mechanism in the position assumed immediately after operation and before being retracted by the closing movement of the drawer; the indicating mechanism in the elevated or exposed position, and the trips restored to normal position. Fig. 5 is a plan view of the machine with the cover removed. Fig. 6 is a horizontal section on the line $x-x$ of Fig. 2.

Referring to the drawings, A designates the cash drawer, suitably arranged and fitted to slide in the case or inclosing frame B of the cash register. Exteriorly arranged on the front of the drawer is a series of knobs or drawer pulls C, mounted upon operating shanks or rods d which are extended through the drawer beneath the till p^2 or cash receptacle proper of the drawer, and guided and adapted to a limited travel or free independent movement therein. Each rod or operating shank d has an engaging head E on its inner end for the purpose hereinafter specified. Spiral springs g coiled around the rods d and compressed between the engaging heads E and the cash drawer serve to normally retain the rods at the rearward limit of their travel. Directly forward and in the paths of the engaging heads E is suspended a swing arm i^2 extending transversely across the case B, and having the journals i^1 pivoted in suitable bearings i^3 which are attached to the cash drawer A at the sides thereof. Said swing arm carries a horizontal latch i attached at one end thereof, the function of which is to engage a catch or hook H fastened upon the side of the case B, thereby being adapted to lock the cash drawer securely in the closed position, as shown in Fig. 2. The swing arm is suitably weighted as shown, to cause the interlocking of the latch and catch automatically as the drawer is closed. Thus arranged, an outward pull upon

either of the drawer pulls C will engage the corresponding engaging head E with the swing arm l^2 , and oscillate both the arm and latch i thereby releasing the drawer, which in operation is then free to be opened by continued pulling upon the drawer pull.

Any suitable system of registering mechanism which is adapted to be operated by a pawl and ratchet motion or analogous mechanical movement may be employed in my improved cash register, according to the registering limit desired.

The simplest form of registering apparatus, and which is here sufficient for purposes of explanation is a single dial, designated by the reference letter L in the drawings, provided with a ratchet l^2 integral therewith and actuated by a pawl l' pivoted to the arm k of the operating lever k^4 , said wheel having its periphery graduated and numbered to conform to the teeth of the ratchet l^2 . The said parts are multiplied to correspond to the series of drawer pulls, and arranged on an arbor k^5 which is secured transversely of the case, with suitable collars k^6 interposed between the respective wheels, which collars are prevented from turning on the arbor by screws or pins k^7 , the points of which are received in a suitable spline k^8 in the arbor. A spring k^9 on the arbor presses the parts together and imposes sufficient friction thereon to hold the registering wheels securely in any position, and in order that the operating levers k^4 may not be subjected to friction they are loosely journaled upon the collars k^6 as shown in the figures, being fitted upon the reduced parts k^{6a} .

Secured upon the rearwardly projecting base F of the cash drawer is a transverse bar or abutment 55, forward and in the path of the ends of the operating levers k^4 as they depend from the arbor k^5 . The upper side of said abutment is beveled rearwardly, as shown, having its highest point of the same height or slightly higher than the engaging heads E. A trip hook j is hinged to the end of each of the operating levers, having its hook j^5 placed at a distance from the forward side of the lever corresponding to the width of the abutment 55. The forward end j^6 of the trip normally rests upon the corresponding engaging head and wholly clear of the abutment 55 when the drawer is in closed position, but in operation, the withdrawal of any of the engaging heads from under the trip, by manipulation of the corresponding drawer pull, will permit the hook to fall by gravity and engage the abutment. Then in the opening movement of the cash drawer the abutment will actuate the trip hook and operating lever forward, thus operating the registering mechanism. The distance through which the cash drawer carries the lever in such opening movement is determined by the proportions of an inclined cam 47 on the rear end of each trip hook, which as the drawer moves outward engages a disengaging bar 52 fixed in the case, thus depressing the cam, and

elevating the trip hook to disengage it from the abutment, which is then free to proceed alone. On the return or closing movement of the drawer, the abutment will engage the lever, and carry it rearward to its original or normal position, and the engaging head will enter beneath the forward end j^6 of the trip hook, all the parts thus being restored to normal position. The rest of the trip hooks as they become depressed from the elevated position during the movement of the drawer and after the abutment 55 leaves them, will be reset by means of the inclined upper face of the abutment as it slides under the forward ends of the hooks. The space between the forward side of the abutment and the rear side of the engaging heads is made somewhat less than the length of the forward end j^6 of a trip hook, so that in the closing movement of the drawer the abutment will not pass out from under the forward end of the trip hooks until the engaging heads have entered beneath them, thus positively insuring the restoration of the parts at each operation of opening the cash drawer.

The registering wheels each bear a series of numbers in arithmetical progression having the number or representative value of the corresponding drawer pull for the lowest terms and also the common difference of the series. The drawer pulls being numbered 5, 10, 20, and "No sale," as hereinbefore described, the "No sale" wheel is numbered 1, 2, 3, 4, 5, 6, &c., the five cent wheel 5, 10, 15, 20, 25, 30, &c., the ten cent wheel 10, 20, 30, 40, &c., and the twenty cent wheel 20, 40, 60, 80, &c. When any wheel has reached its full registering limit all the wheels may be reset to zero by turning them ahead on their arbor until the zero mark is brought contiguous to the reading bar r on the side toward the cover of the case. The manipulation of any individual drawer pull, and the opening of the drawer thereby, thus will accomplish the registration of the action by advance of the corresponding registering wheel, the numbers of which may be read from a position just rearward of the reading bar r , when the cover 7^{10} is removed, as shown in Fig. 5. The registering wheels corresponding to the remaining drawer pulls which are not manipulated, will not be disturbed by the aforesaid opening movement of the drawer. But if two or more drawer pulls are operated in combination, as for instance the five cent and ten cent knobs, then corresponding registration of two or more wheels will take place, the same as if operated in successive movements of the drawer, the sum of the amounts registered being the value of the sale. It is immaterial in such operation which of the knobs of the combination is first pulled, or whether they are drawn singly or together, provided that the drawer is not opened before the withdrawal of the last knob.

The indication of the sales is performed as follows: Each of the operating levers k^4 is

provided with an arm m' which normally supports a rod m^4 arranged to slide vertically in the guides m^5 in the case, said rods bearing indicator tablets m^2 at their upper ends, which are raised and exposed to view through the slots m^3 in the case by means of the oscillation of the arms m' and operating levers k^4 by the opening movement of the drawer, the tablets being numbered to conform to the values of the corresponding drawer pulls, and adapted to indicate sales as determined by the manipulation of any particular knob. The rods m^4 are provided with projecting shoulders n beveled on their upper sides to form catches, adapted in their upward movement to push aside and swing the pawl n' hinged in the case, which then slides under the said projections, actuated by a suitable spring n^{10} fastened to the case, thereby holding the indicator tablets and their rods in the elevated position shown in Fig. 4, after the restoration of the operating levers to their original position. In this position the particular tablet raised by opening the drawer will remain until the next succeeding movement of the drawer, when the pushing aside of the pawl n' by the shoulder n thus being raised, will liberate the shoulder and rod previously raised, and the first tablet will drop out of sight to its original position. But in order to provide sufficient swing of the pawl n to insure inevitable release of all the indicator tablets even when some of the shoulders n are slightly longer than the others, the cash drawer carries a spring hook n^4 which in the opening movement of the drawer is adapted to engage, swing and release from the end of a lever n^2 depending from and integral with the pawl n' thus amply oscillating said pawl about the time that the beveled side of the shoulder n operates upon it, and insuring plenty of clearance to liberate the tablets and rods. Said lever n^2 carries a bell hammer p which in the said movement of the pawl is adapted to strike a bell p' attached on the case, thus announcing the act of opening the drawer.

I claim as my invention—

1. In a cash register the combination of an inclosing case, a cash drawer therein, a series of exterior knobs or drawer pulls and their operating rods movably mounted and carried on the drawer, latch mechanism for automatically locking the drawer in the case, and means for unlocking the latch mechanism by initial action of the drawer pulls, registering mechanism and operating levers therefor provided with movable trip hooks or latches, an actuating abutment or carrier mounted on the cash drawer, means for normally retaining the trip hooks free of the carrier and tripping them to hook upon the same by initial movement of the drawer pulls, and means for releasing the trip hooks from the carrier at a given point in the travel of the drawer, whereby the registration is effected by the opening

movement of the drawer, substantially as and for the purpose specified.

2. In a cash register the combination of an inclosing case, a cash drawer therein, a series of exterior knobs or drawer pulls having operating rods guided and adapted to a limited independent movement in the drawer, means for locking the drawer in the case, comprising a fixed hook and a vibratory latch relatively mounted upon the drawer and case, a swing arm connected to vibrate conjointly with the latch, engaging heads carried upon said operating rods and adapted to individually operate the swing arm and latch to release the drawer by initial movement of the drawer pulls, a series of registering mechanisms corresponding to the series of drawer pulls, operating levers and pawl and ratchet mechanism for operating the registering mechanisms, the series of trip hooks hinged or pivoted to the registering levers normally supported by the engaging heads, and a carrier or abutment secured upon the cash drawer and adapted in the opening movement thereof to operate the registering mechanism by engagement with the trip hooks when said trip hooks are released from the engaging heads by initial withdrawal of the drawer pulls, substantially as and for the purpose specified.

3. In a cash register the combination of the cash drawer, a series of drawer pulls and their connections guided and adapted to a limited independent movement in the drawer, the registering wheels, their operating levers, pawls and ratchets, the trip hooks or catches hinged or movably connected to said levers, a carrier or abutment carried on the cash drawer, means substantially as described for engaging the trip hooks with said carrier by the initial movement of the drawer pulls to operate the registering mechanism by the opening movement of the drawer, and the means for releasing the trip hooks from the carrier at the end of the throw of the registering lever, substantially as and for the purpose specified.

4. In a cash register the combination of the cash drawer, the registering wheels, their operating levers, pawls, and ratchets, the trip hooks pivoted to the said levers, a carrier or abutment carried on the cash drawer, means substantially as described for engaging the trip hooks and carrier to operate the registering mechanism by movement of the cash drawer, means substantially as described for releasing the trip hooks and carrier at a given position of the drawer a series of indicator tablets corresponding to the drawer pulls, levers for supporting the tablets, a holding latch for securing the indicator tablets in exposed position, and the release mechanism for disengaging the same, substantially as and for the purpose specified.

5. In a cash register the combination of an inclosing case, a cash drawer therein, a series of exterior knobs or drawer pulls having op-

erating rods guided and adapted to a limited independent movement in the drawer and carrying engaging heads, a movable part or swing arm guided or hinged upon and carried with the cash drawer in the paths of and subject to engagement by the said engaging heads, a vibratory latch connected to operate with the said swing bar by the initial movement of the drawer pulls and their operating rods and engaging heads, and a fixed hook or catch on the case or frame, adapted to be engaged by said latch to lock the drawer in closed position, the registering levers, pawls, wheels, and ratchets, the trips pivoted to the said levers normally supported by the engaging heads, a carrier or abutment carried by the drawer adapted to operate the levers by engagement with the trips on the opening movement of the drawer and retract them in the return movement thereof, said trip hooks having cam surfaces or releasing shoulders and the case being provided with a bar or stop in the path of said shoulders adapted to intercept and release the trips from the carrier, substantially in the manner and for the purpose specified.

6. In a cash register the combination of an inclosing case, a cash drawer therein, a series of exterior knobs or drawer pulls having operating rods guided and adapted to a limited

independent movement in the drawer, release mechanism substantially as described for unlocking the cash drawer by initial movement of the drawer pulls, a series of registering wheels and their ratchets, pawls for driving the ratchets, the operating levers for reciprocating the pawls, the trip hooks carried by said levers, the beveled lever actuating abutment carried by the drawer, the liberating mechanism for releasing the trips from said abutment, the arms carried by the registering levers, the rods and indicator tablets guided in the case and supported by said arms, the rods being provided with catches or beveled projections, a pawl adapted to swing under and engage said catches when the tablets are elevated into exposed position, a lever attached to the pawl, a spring for retaining the pawl in position to support the tablets in their exposed position, and a spring hook or elastic catch carried by the drawer and adapted to withdraw the pawl from engagement with the tablet rods to release the same by the movement of the cash drawer, substantially as and for the purpose specified.

THOMAS CARROLL.

Witnesses:

LEVI W. BROWN,
CHARLES CARROLL.