

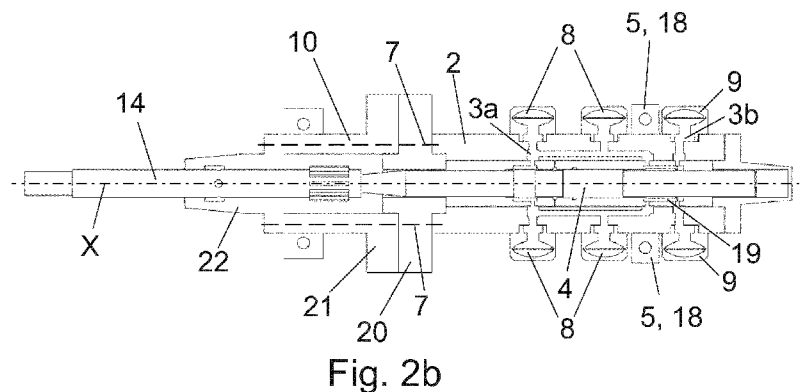

(43) International Publication Date
17 September 2020 (17.09.2020)

- (51) International Patent Classification:
E21B 4/14 (2006.01) *B25D 9/14* (2006.01)
- (21) International Application Number:
PCT/EP2020/057161
- (22) International Filing Date:
16 March 2020 (16.03.2020)
- (25) Filing Language: English
- (26) Publication Language: English
- (30) Priority Data:
19162773.6 14 March 2019 (14.03.2019) EP
- (71) Applicant: SANDVIK MINING AND CONSTRUCTION OY [FI/FI]; Pihtisulunkatu 9, 33330 Tampere (FI).
- (72) Inventors: KOSKIMÄKI, Antti; Pihtisulunkatu 9, 33330 Tampere (FI). HÄMÄLÄINEN, Mikko; Pihtisulunkatu 9, 33330 Tampere (FI).
- (74) Agent: SANDVIK ASSOCIATION; Sandvik Mining and Construction Oy PL 100, 33311 Tampere (FI).
- (81) Designated States (unless otherwise indicated, for every kind of national protection available): AE, AG, AL, AM, AO, AT, AU, AZ, BA, BB, BG, BH, BN, BR, BW, BY, BZ, CA, CH, CL, CN, CO, CR, CU, CZ, DE, DJ, DK, DM, DO, DZ, EC, EE, EG, ES, FI, GB, GD, GE, GH, GM, GT, HN, HR, HU, ID, IL, IN, IR, IS, JO, JP, KE, KG, KH, KN, KP, KR, KW, KZ, LA, LC, LK, LR, LS, LU, LY, MA, MD, ME, MG, MK, MN, MW, MX, MY, MZ, NA, NG, NI, NO, NZ, OM, PA, PE, PG, PH, PL, PT, QA, RO, RS, RU, RW, SA, SC, SD, SE, SG, SK, SL, ST, SV, SY, TH, TJ, TM, TN, TR, TT, TZ, UA, UG, US, UZ, VC, VN, WS, ZA, ZM, ZW.
- (84) Designated States (unless otherwise indicated, for every kind of regional protection available): ARIPO (BW, GH,

(54) Title: ROCK DRILLING ARRANGEMENT AND MACHINE

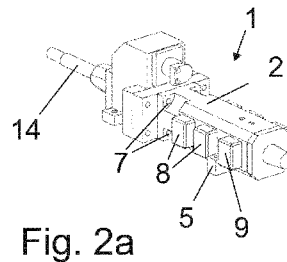

(57) Abstract: A rock drilling arrangement (100), comprising an impact device (1) comprising a frame (2) pressure chambers (3a, 3b) in the frame (2), and a piston (4) arranged in the impact device (1). The arrangement further comprises a rear mounting arrangement (5) for attaching the impact device (1) to a carriage (6), a front mounting arrangement (7) for attaching the impact device (1) to a machine component (10), at least one fore pressure accumulator (8) arranged on front side of the rear mounting arrangement (5) in an axial direction (X) of the piston, and at least one rear pressure accumulator (9) arranged on back side of the rear mounting arrangement (5). The fore pressure accumulator (8) and the rear pressure accumulator (9) are connected to one of the pressure chambers (3a, 3b) and arranged to absorb pressure fluctuations in said pressure chambers (3a, 3b).



GM, KE, LR, LS, MW, MZ, NA, RW, SD, SL, ST, SZ, TZ,
UG, ZM, ZW), Eurasian (AM, AZ, BY, KG, KZ, RU, TJ,
TM), European (AL, AT, BE, BG, CH, CY, CZ, DE, DK,
EE, ES, FI, FR, GB, GR, HR, HU, IE, IS, IT, LT, LU, LV,
MC, MK, MT, NL, NO, PL, PT, RO, RS, SE, SI, SK, SM,
TR), OAPI (BF, BJ, CF, CG, CI, CM, GA, GN, GQ, GW,
KM, ML, MR, NE, SN, TD, TG).

Published:

— *with international search report (Art. 21(3))*

ROCK DRILLING ARRANGEMENT AND MACHINE

BACKGROUND

The invention relates to a rock drilling arrangement.

The invention further relates to a rock drilling machine.

Rock drilling machines comprise an impact device that provides impact pulses to a tool for drilling material being operated. The impact device comprises a reciprocating piston that moves towards an impact direction and a return direction. The impact device comprises a rear pressure chamber and a front pressure chamber. In order to move the piston into the impact direction, a high pressure is provided into the rear pressure chamber. For moving the percussion piston back, a low pressure is provided into the rear pressure chamber, whereby the percussion piston moves back by an effect of a high pressure remaining constantly in the front pressure chamber. However, the movement of the piston may also be realized some other way, too.

Due to a continuous variation of the pressure of pressure medium in pressure chambers, cavitation may occur in the pressure chambers. This may lead to deterioration of the impact device. In order to decrease risk to cavitation, pressure accumulators are known to connect to the pressure chambers.

Use of long piston in impact device is advantageous when drilling holes having large diameter, because the long piston provides a better impact dynamics than a piston having regular dimensions. The long piston is clearly longer than a regular piston.

A problem with the long piston impact devices is that due to their dimensions, they require much more space compared to regular impact devices.

BRIEF DESCRIPTION

Viewed from a first aspect, there can be provided a rock drilling arrangement, comprising an impact device comprising a frame, pressure chambers in the frame, a piston arranged in the impact device, a rear mounting arrangement for attaching the impact device to a carriage, a front mounting arrangement for attaching the impact device to a machine component, at least one fore pressure accumulator arranged on front side of the rear mounting arrangement in an axial direction of the piston, and at least one rear pressure accumulator arranged on back side of the rear mounting arrangement, the fore pressure accumulator and the rear pressure accumulator being connected to one of the pressure chambers and arranged to absorb pressure fluctuations in said pressure chambers.

Thereby a rock drilling arrangement fitting in commonly used drilling machines may be achieved. Furthermore, a rock drilling arrangement having high capacity of pressure accumulators and thus ability to absorb pressure vibrations may be achieved.

Viewed from a second aspect, there can be provided a rock drilling machine comprising the drilling arrangement described above.

The arrangement and the method are characterised by what is stated in the independent claims. Some other embodiments are characterised by what is stated in the other claims. Inventive embodiments are also disclosed in the specification and drawings of this patent application. The inventive content of the patent application may also be defined in other ways than defined in the following claims. The inventive content may also be formed of several separate inventions, especially if the invention is ex-

amined in the light of expressed or implicit sub-tasks or in view of obtained benefits or benefit groups. Some of the definitions contained in the following claims may then be unnecessary in view of the separate inventive ideas. Features of the different embodiments of the invention may, within the scope of the basic inventive idea, be applied to other embodiments.

In one embodiment, the arrangement comprises at least two fore pressure accumulators. An advantage is that the accumulators are close to the front pressure chamber.

In one embodiment, the arrangement comprises four fore pressure accumulators. An advantage is that total volume of the pressure accumulators connected to pressure chambers arranged in the frame may be increased.

In one embodiment, the arrangement comprises at least two rear pressure accumulators. An advantage is that it is possible to arrange the accumulators close to a rear pressure chamber of the piston.

In one embodiment, at least one of the fore pressure accumulator(s) is a high pressure (HP) accumulator, the pre-charge pressure of which is in range of 50 - 150 bar. An advantage is that high pressure for providing an effective impact movement of the piston may be maintained in the front pressure chamber. In an embodiment, the pressure range is 50 - 100 bar. An advantage is that life-time of the components of the high pressure (HP) accumulator, such as an elastic diaphragm, may be extended.

In one embodiment, each of the fore pressure accumulator(s) is a high pressure (HP) accumulator. An advantage is that location of the HP accumulators may be optimized in relation to the piston.

In one embodiment, at least one of the rear pressure accumulator(s) is a low pressure (LP) accumulator, the pre-charge pressure of which is in range of 1 - 5 bar. An advantage is that the LP accumulators are close to the rear pressure chamber of the piston and may decrease risk to cavitation therein. In an embodiment, the pressure is 2 - 4 bar that is especially matching with typical tank pressure used with impact devices.

In one embodiment, each of the rear pressure accumulator(s) is a low pressure (LP) accumulator. An advantage is that risk to cavitation may be decreased effectively.

In one embodiment, the pressure accumulator is arranged on a side of the frame. An advantage is that the accumulator does not obstruct attachment of the impact device in the drilling arrangement.

In one embodiment, at least one of the pressure accumulators is arranged on a top of the frame. An advantage is that number and capacity of the pressure accumulators may be increased.

In one embodiment, the arrangement comprises two low pressure (LP) accumulators arranged at different positions in the axial direction X of the piston. An advantage is that the positions of the LP accumulators may be optimized in relation to the pressure chambers of the impact device.

In one embodiment, all the pressure accumulators are of same size. An advantage is that at least some of the parts of the accumulators may be identical, thus simplifying the service of the impact device.

In one embodiment, the rear mounting arrangement is aligned perpendicular in relation to the axial direction. An advantage is that the impact device is simple to attach to carriages commonly used in rock drilling machines.

In one embodiment, the rear mounting arrangement is aligned obliquely in relation to the axial direction. An advantage is that the position of the rear mounting makes it possible to optimize locations of the pressure accumulators.

In one embodiment, the piston is a long piston. An advantage is that it may provide better impact dynamics especially in making large-diameter holes.

BRIEF DESCRIPTION OF FIGURES

Some embodiments illustrating the present disclosure are described in more detail in the attached drawings, in which

Figure 1 is a schematic side view of a drilling machine,

Figure 2a is a schematic perspective view of a detail of an arrangement,

Figure 2b is a schematic side view of a detail of an arrangement in partial cross-section, and

Figures 3a - 3d are schematic side views of details of embodiments.

In the figures, some embodiments are shown simplified for the sake of clarity. Similar parts are marked with the same reference numbers in the figures.

DETAILED DESCRIPTION

Figure 1 is a schematic side view of a drilling machine that comprises a rock drilling arrangement 100. The rock drilling arrangement 100 is connected by means of a boom 12 to a movable carrier 11. However, the rock drilling arrangement 100 may be arranged to the carrier 11 some another way, too.

The shown movable carrier 11 moves on wheels. In another embodiments, the carrier 11 moves e.g. on tracks.

The rock drilling arrangement 100 is attached to a carriage 6 that is arranged in a feed beam 13. The carriage 6 and the rock drilling arrangement 100 therewith may be moved on the feed beam 13 by means of a feed device (not shown).

The rock drilling arrangement 100 comprises a shank 14 (shown in Figures 2a, 2b) at a front end thereof for connecting a tool 15. The tool 15 may comprise one or more drill rods 16 and a drill bit 17 arranged at a distal end of the tool 15.

The rock drilling arrangement 100 may further comprise a rotating device (not shown) for rotating the shank 14 and the tool 15.

The rock drilling arrangement 100 comprises an impact device 1 that is arranged to generate impact pulses to the tool 15. The details of the impact device are described later in this description.

At a drilling site, one or more drill holes are drilled with the rock drilling unit 100. The drill holes may be drilled in a horizontal direction, as shown in Figure 1, or in a vertical direction, or in any direction between

the horizontal direction and the vertical direction. The disclosed solution is known as top-hammer drilling.

Figure 2a is a schematic perspective view and **Figure 2b** is a schematic side view of a detail of a rock drilling arrangement in partial cross-section.

The rock drilling arrangement 100 has an impact device 1 comprising a frame 2, pressure chambers 3a, 3b in the frame 2, and a reciprocating piston 4 arranged in the impact device 1. The piston may be arranged to move to and fro in the frame 2 in axial direction X of the piston during a work cycle of the impact device 1. Said movement of the piston 4 is energized by pressurized pressure medium, typically hydraulic fluid, directed to the pressure chambers 3a, 3b of the frame and acting on working pressure surfaces of the piston 4. In the embodiment shown in Figure 2b, a distributor 19 controls access of fluid in the pressure chambers such that a suitable force moving the piston is caused between pressure chambers of the piston.

In an embodiment, the piston 4 used is clearly longer than regular piston. It is to be noted, however, that the invention may also be applied to impact devices comprising a piston having a regular length.

A rear mounting arrangement 5 is arranged for attachment the frame 2 to the carriage 6. The rear mounting arrangement 5 shown in Figures comprises two fastening lugs 18 having a through hole as a mounting hole and arranged perpendicular in relation to the axial direction.

A fastening device, such as screw or bolt, may be fitted in the mounting hole. The mounting hole may be blank or comprise thread(s). In an embodiment, the rear mounting arrangement 5 is without any attachment means, but just

comprises a contact surface that is arranged to take at least part of the weight of the impact device 1 and passing said weight to an underlying structure of the rock drilling arrangement 100, for instance to the carriage 6.

In another embodiment, the rear mounting arrangement 5 is realized without lugs or similar features but comprises a collar element that extends over the frame 2 and attaches the impact device 1 to e.g. the carriage 6.

Additionally, the impact device 1 may comprise at least one front mounting arrangement 7 for attaching the impact device 1 to a machine component 10. In the embodiment shown in Figures 2a, 2b, said machine component 10 is a spacer element 20 that is arranged between the impact device 1 and a gear box 21. The front mounting arrangement 7 comprises mounting holes that corresponds to mounting holes in said spacer element 20. The embodiment shown in Figures 2a, 2b comprises also a flushing unit 22 attached to the gear box 21.

In an embodiment, the machine component 10 is a gear box.

In an embodiment, the machine component 10 is a flushing unit.

In still another embodiment, the machine component 10 is the same carriage 6 to which the rear mounting arrangement 5 is attached.

According to an aspect, the impact device 1 comprises at least one fore pressure accumulator 8 arranged on front side of the rear mounting arrangement 5 in an axial direction X of the piston, and at least one rear pressure accumulator 9 arranged on back side of the rear mounting arrangement 5. The fore and the rear pressure accumulators

8, 9 are connected to one of the pressure chambers 3a, 3b of the frame.

The "front side of the rear mounting arrangement" means in this description parts or sections of the impact device lying between the rear mounting arrangement and the tool 15.

The "back side of the rear mounting arrangement" means in this description parts or sections of the impact device not lying between the rear mounting arrangement and the tool 15.

In the embodiment shown in Figure 2, there are four fore pressure accumulators 8 and two rear pressure accumulators 9 in the impact device 1.

Placing some of the accumulators 8, 9 on back side of the rear mounting arrangement 5 makes it possible to select the location of the rear mounting arrangement 5 so that even an impact device 1 equipped with a long piston may be attached to a carriage dimensioned for drilling machines dimensioned for impact devices having a regular piston.

The pressure accumulator 8, 9 is practically pressure storage reservoir in which hydraulic fluid is held under pressure that is applied by an external source. In the shown embodiment, the external source is a compressed gas. The gas may be e.g. nitrogen gas.

In this embodiment, the pressure accumulator comprises a cylinder with two chambers that are separated by an elastic diaphragm, a totally enclosed bladder, or a floating piston. One of the chambers contains hydraulic fluid and is connected to one of the pressure chambers 3a, 3b of the frame. The other chamber of the pressure accumulator con-

tains the gas under pressure that provides the compressive force on the hydraulic fluid. As the volume of the compressed gas changes, the pressure of the gas and the pressure on the hydraulic fluid changes inversely.

It is to be noted that in some another embodiments, the external source may be created instead of gas by e.g. a spring.

The pressure accumulators 8, 9 enable the hydraulic system of the impact device 1 to respond more quickly to a temporary demand of fluid, and to smooth out pulsations. It is a type of energy storage device. Additionally, especially the low pressure accumulators may reduce risks to cavitation in those pressure chambers of the frame and/or pressure chambers of the piston in which it is connected to.

The pressure accumulators 8, 9 are arranged on two sides of the frame 2 of the impact device such that the accumulators on a first side are face to face or opposite to the accumulators on a second side of the frame 2, i.e. they are in same position in the axial direction X of the piston. However, this arrangement is not compulsory one.

In the embodiment shown in Figure 2, all the fore pressure accumulators 8 are a high pressure (HP) accumulators, the pre-charge pressure of which may be selected in range of 50 - 150 bar, preferably 50 - 100 bar. Multiple HP accumulators may reduce pressure-pulses of a pressure hoses connected to the impact device 1.

Additionally, all the rear pressure accumulators 9 are low pressure (LP) accumulators. The pre-charge pressure of the low pressure accumulator may be selected in range of 1 - 5 bar, preferably 2 - 4 bar.

It is to be noted, however, that LP and HP accumulators may be organized differently in relation to the rear mounting arrangement 5.

In an embodiment, there are both LP and HP accumulators in the fore pressure accumulators 8. Also the rear pressure accumulators 9 may comprise both LP and HP accumulators. Thus there are short distance from at least one LP and one HP accumulators to the pressure chambers 3a, 3b.

In an embodiment, two LP accumulators are attached at least substantially opposite positions in the frame 2.

In an embodiment, two HP accumulators are attached at least substantially opposite positions in the frame 2.

In an embodiment, a LP accumulator is attached at least substantially opposite position with a HP accumulator.

Figures 3a - 3d are schematic side views of details of embodiments.

In **Figure 3a** it is shown an embodiment that comprises just one fore pressure accumulator 8 and one rear pressure accumulator 9. In some aspects, this may be the simplest embodiment of the invention. In an embodiment, the fore pressure accumulator 8 is a HP accumulator connected to the front pressure chamber of the frame 2, whereas the rear pressure accumulator 9 is a LP accumulator connected to the rear pressure chamber of the frame. It is to be noted, that the fore pressure accumulator 8 and the rear pressure accumulator 9 may be arranged on the same side of the frame 2. Furthermore, it is possible to arrange at least one of the accumulators on top of the frame 2, i.e. opposite position in relation to the carriage.

Figure 3b is showing an embodiment comprising three fore pressure accumulators 8 and two rear pressure accumulators 9. In an embodiment, the fore pressure accumulators 8 are HP accumulators both fore accumulators being connected to the front pressure chamber 3a of the frame 2. The rear pressure accumulators 9 are LP accumulators and connected to the rear pressure chamber 3b of the frame.

In some embodiments of the invention, at least one of the fore and rear pressure accumulators 8, 9 is arranged on a top of the frame 2. **Figure 3b** is showing an embodiment where one of the fore pressure accumulators 8 is arranged on top of the frame 2.

In an embodiment, the impact device comprises pressure accumulators having at least two sizes. **Figure 3c** is showing an example of this embodiment, which comprises four fore pressure accumulators 8, including two smaller accumulators and two larger accumulators. By selecting the size of the accumulators it is possible to optimize performance of the impact device 1 for working operations to be executed.

Figure 3d is showing an example of embodiments wherein the rear mounting arrangement 5 is aligned obliquely in relation to the axial direction X.

The invention is not limited solely to the embodiments described above, but instead many variations are possible within the scope of the inventive concept defined by the claims below. Within the scope of the inventive concept the attributes of different embodiments and applications can be used in conjunction with or replace the attributes of another embodiment or application.

The drawings and the related description are only intended to illustrate the idea of the invention. The invention may

vary in detail within the scope of the inventive idea defined in the following claims.

REFERENCE SYMBOLS

1	impact device
2	frame
3a, b	pressure chamber
4	piston
5	rear mounting arrangement
6	carriage
7	front mounting arrangement
8	fore pressure accumulator
9	rear pressure accumulator
10	machine component
11	carrier
12	boom
13	feed beam
14	shank
15	tool
16	drill rod
17	drill bit
18	fastening lug
19	distributor
20	spacer element
21	gear box
22	flushing unit
100	rock drilling arrangement
X	axial direction

CLAIMS

1. A rock drilling arrangement (100), comprising
 - an impact device (1) comprising
 - a frame (2),
 - pressure chambers (3a, 3b) in the frame (2),
 - a piston (4) arranged in the impact device (1),
 - a rear mounting arrangement (5) for attaching the impact device (1) to a carriage (6),
 - a front mounting arrangement (7) for attaching the impact device (1) to a machine component (10),
 - at least one fore pressure accumulator (8) arranged on front side of the rear mounting arrangement (5) in an axial direction (X) of the piston, and
 - at least one rear pressure accumulator (9) arranged on back side of the rear mounting arrangement (5),
 - the fore pressure accumulator (8) and the rear pressure accumulator (9) being connected to one of the pressure chambers (3a, 3b) and arranged to absorb pressure fluctuations in said pressure chambers (3a, 3b).
2. The arrangement as claimed in claim 1, comprising at least two fore pressure accumulators (8).
3. The arrangement as claimed in claim 1 or 2, comprising four fore pressure accumulators (8).
4. The arrangement as claimed in any of the preceding claims, comprising at least two rear pressure accumulators (9).
5. The arrangement as claimed in any of the preceding claims, wherein at least one of the fore pressure accumulator(s) (8) is a high pressure (HP) accumulator, the pre-charge pressure of which is in range of 50 - 150 bar, preferably 50 - 100 bar.

6. The arrangement as claimed in claim 5, wherein each of the fore pressure accumulator(s) (8) is a high pressure (HP) accumulator.

7. The arrangement as claimed in any of the preceding claims, wherein at least one of the rear pressure accumulator(s) (9) is a low pressure (LP) accumulator, the pre-charge pressure of which is in range of 1 - 5 bar, preferably 2 - 4 bar.

8. The arrangement as claimed in claim 7, wherein each of the rear pressure accumulator(s) (9) is a low pressure (LP) accumulator.

9. The arrangement as claimed in any of the preceding claims, wherein the pressure accumulator (8, 9) is arranged on a side of the frame (2).

10. The arrangement as claimed in any of the preceding claims, wherein at least one of the pressure accumulators (8, 9) is arranged on a top of the frame (2).

11. The arrangement as claimed in any of the preceding claims, comprising two low pressure (LP) accumulators arranged at different positions in the axial direction (X) of the piston.

12. The arrangement as claimed in any of the preceding claims, wherein the rear mounting arrangement (5) is aligned perpendicular in relation to the axial direction (X).

13. The arrangement as claimed in any of claims 1 - 12, wherein the rear mounting arrangement (5) is aligned obliquely in relation to the axial direction (X).

14. A rock drilling machine comprising a drilling arrangement (100) according any one of the preceding claims.

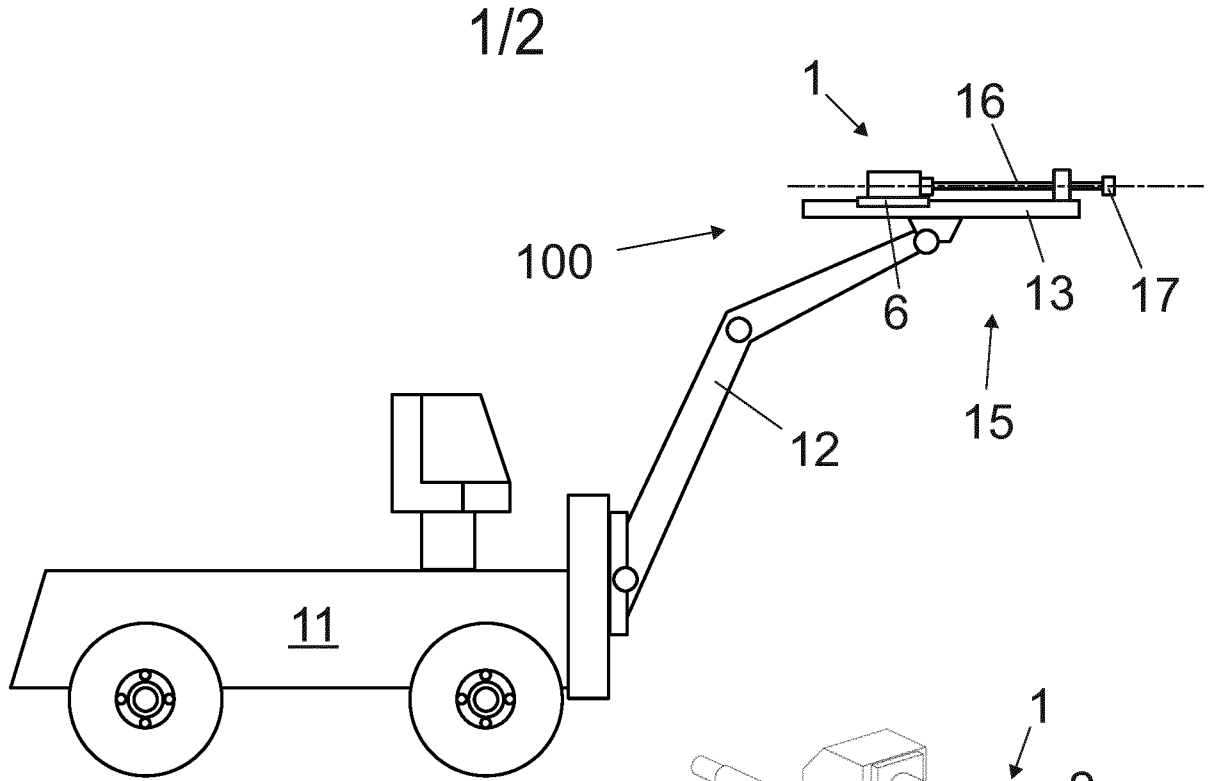

Fig. 1

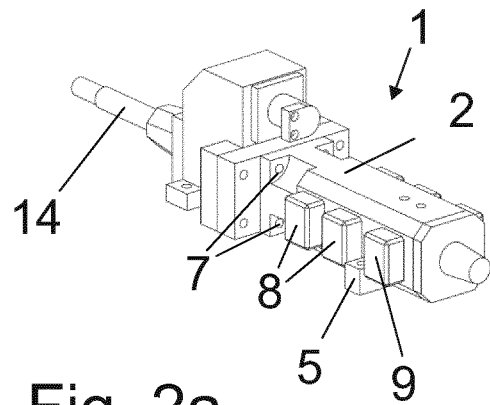

Fig. 2a

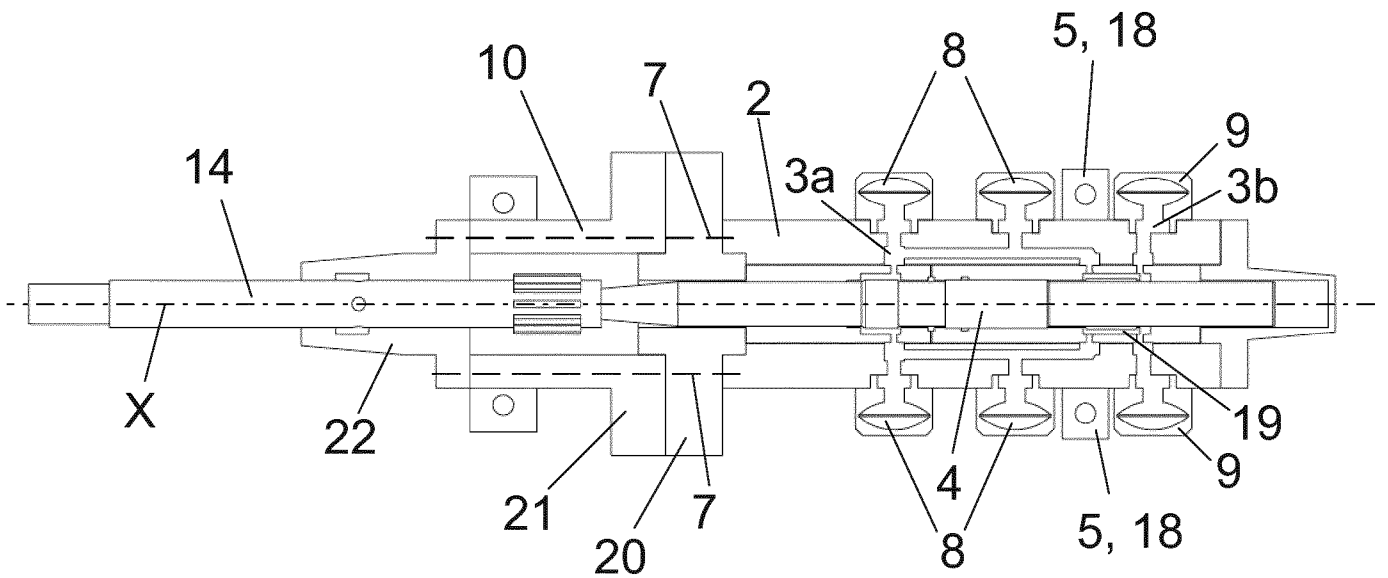

Fig. 2b

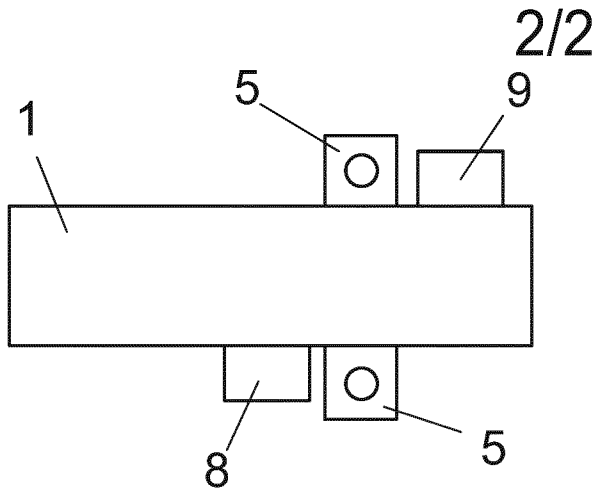

Fig. 3a

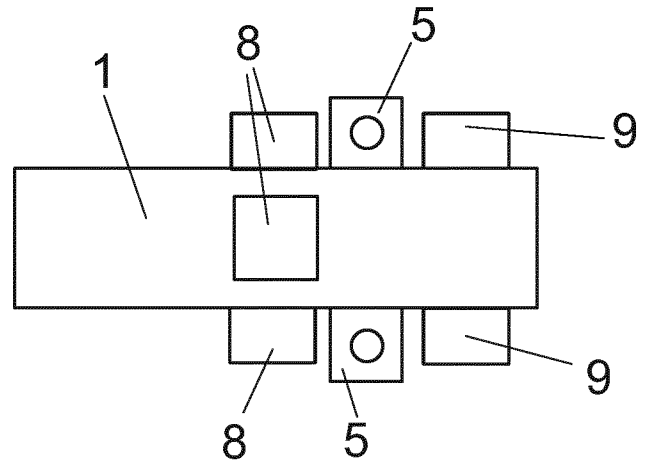

Fig. 3b

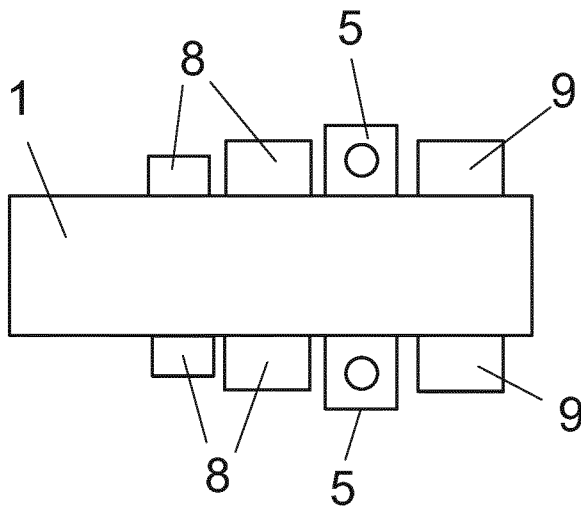

Fig. 3c

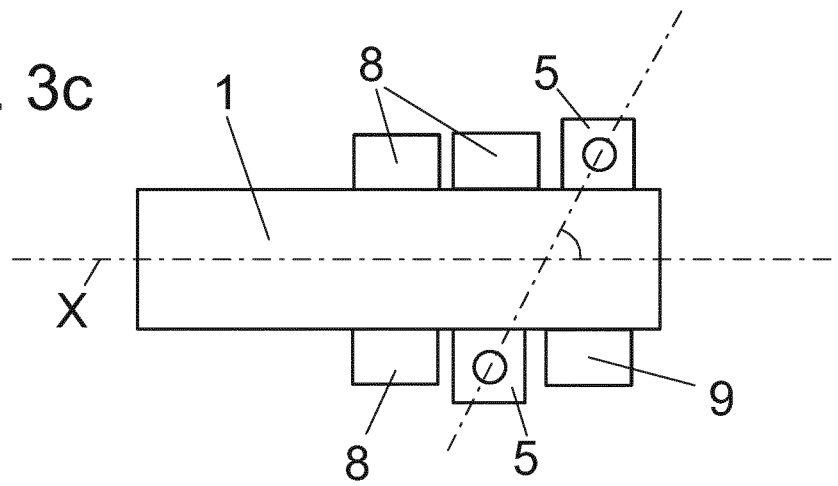

Fig. 3d

INTERNATIONAL SEARCH REPORT

International application No
PCT/EP2020/057161

A. CLASSIFICATION OF SUBJECT MATTER
 INV. E21B4/14 B25D9/14
 ADD.
 According to International Patent Classification (IPC) or to both national classification and IPC

B. FIELDS SEARCHED
 Minimum documentation searched (classification system followed by classification symbols)
 B25D E21B

Documentation searched other than minimum documentation to the extent that such documents are included in the fields searched

Electronic data base consulted during the international search (name of data base and, where practicable, search terms used)
 EPO-Internal, WPI Data

C. DOCUMENTS CONSIDERED TO BE RELEVANT

Category*	Citation of document, with indication, where appropriate, of the relevant passages	Relevant to claim No.
A	US 2016/001432 A1 (KELA TIMO [FI] ET AL) 7 January 2016 (2016-01-07) page 2, paragraph 26 - page 4, paragraph 46; figures 1,3	1-14
A	WO 2010/058073 A1 (SANDVIK MINING & CONSTR OY [FI]; MUUTTONEN TIMO [FI] ET AL.) 27 May 2010 (2010-05-27) figure 5	1-14
A	WO 2016/148575 A1 (RESONATOR AS [NO]) 22 September 2016 (2016-09-22) the whole document	1-14
A	US 2015/053076 A1 (LUNDGREN ANDERS [SE]) 26 February 2015 (2015-02-26) the whole document	1-14
	----- -/--	

Further documents are listed in the continuation of Box C.

See patent family annex.

* Special categories of cited documents :

<p>"A" document defining the general state of the art which is not considered to be of particular relevance</p> <p>"E" earlier application or patent but published on or after the international filing date</p> <p>"L" document which may throw doubts on priority claim(s) or which is cited to establish the publication date of another citation or other special reason (as specified)</p> <p>"O" document referring to an oral disclosure, use, exhibition or other means</p> <p>"P" document published prior to the international filing date but later than the priority date claimed</p>	<p>"T" later document published after the international filing date or priority date and not in conflict with the application but cited to understand the principle or theory underlying the invention</p> <p>"X" document of particular relevance; the claimed invention cannot be considered novel or cannot be considered to involve an inventive step when the document is taken alone</p> <p>"Y" document of particular relevance; the claimed invention cannot be considered to involve an inventive step when the document is combined with one or more other such documents, such combination being obvious to a person skilled in the art</p> <p>"&" document member of the same patent family</p>
---	---

Date of the actual completion of the international search 6 May 2020	Date of mailing of the international search report 15/06/2020
--	---

Name and mailing address of the ISA/ European Patent Office, P.B. 5818 Patentlaan 2 NL - 2280 HV Rijswijk Tel. (+31-70) 340-2040, Fax: (+31-70) 340-3016	Authorized officer Morrish, Susan
--	---

INTERNATIONAL SEARCH REPORT

International application No
PCT/EP2020/057161

C(Continuation). DOCUMENTS CONSIDERED TO BE RELEVANT		
Category*	Citation of document, with indication, where appropriate, of the relevant passages	Relevant to claim No.
A	US 3 741 072 A (ROMELL G ET AL) 26 June 1973 (1973-06-26) the whole document	1-14
A	----- US 3 470 970 A (MAHY RAYMOND MARCEL ET AL) 7 October 1969 (1969-10-07) the whole document -----	1-14

INTERNATIONAL SEARCH REPORT

Information on patent family members

International application No
PCT/EP2020/057161

Patent document cited in search report	Publication date	Patent family member(s)	Publication date
US 2016001432	A1	07-01-2016	
		AU 2015203560 A1	21-01-2016
		CA 2894293 A1	03-01-2016
		CL 2015001885 A1	29-07-2016
		CN 105239923 A	13-01-2016
		EP 2963230 A1	06-01-2016
		KR 20160004941 A	13-01-2016
		US 2016001432 A1	07-01-2016

WO 2010058073	A1	27-05-2010	
		FI 20086099 A	21-05-2010
		WO 2010058073 A1	27-05-2010

WO 2016148575	A1	22-09-2016	
		NO 337771 B1	20-06-2016
		WO 2016148575 A1	22-09-2016

US 2015053076	A1	26-02-2015	
		CA 2863539 A1	22-08-2013
		SE 1250135 A1	18-08-2013
		US 2015053076 A1	26-02-2015
		WO 2013122533 A1	22-08-2013
		ZA 201405131 B	25-01-2017

US 3741072	A	26-06-1973	NONE

US 3470970	A	07-10-1969	
		AT 287620 B	25-01-1971
		BE 724324 A	02-05-1969
		CH 494093 A	31-07-1970
		DE 1810475 A1	19-06-1969
		FR 1593334 A	25-05-1970
		GB 1248604 A	06-10-1971
		NL 6816761 A	28-05-1969
		US 3470970 A	07-10-1969
