



(86) Date de dépôt PCT/PCT Filing Date: 1997/02/11  
 (87) Date publication PCT/PCT Publication Date: 1997/08/21  
 (45) Date de délivrance/Issue Date: 2008/04/22  
 (85) Entrée phase nationale/National Entry: 1998/08/13  
 (86) N° demande PCT/PCT Application No.: US 1997/002220  
 (87) N° publication PCT/PCT Publication No.: 1997/029793  
 (30) Priorités/Priorities: 1996/02/13 (US08/600,744);  
 1996/10/02 (US08/726,313)

(51) Cl.Int./Int.Cl. *C08J 3/28* (2006.01),  
*A61F 2/32* (2006.01), *A61F 2/46* (2006.01),  
*A61L 27/00* (2006.01), *A61L 27/16* (2006.01),  
*A61F 2/30* (2006.01), *A61F 2/00* (2006.01),  
*A61F 2/34* (2006.01), *A61F 2/36* (2006.01),  
*B29C 35/08* (2006.01), *B29C 43/00* (2006.01),  
*B29C 43/16* (2006.01), *C08F 110/02* (2006.01)

(72) Inventeurs/Inventors:  
 MERRILL, EDWARD W., US;  
 HARRIS, WILLIAM H., US;  
 JASTY, MURALI, US;

(73) Propriétaires/Owners:

(54) Titre : DISPOSITIFS DE PROTHESE A BASE DE POLYETHYLENE A POIDS MOLECULAIRE TRES ELEVE,  
 TRAITES PAR FUSION ET RAYONNEMENT  
 (54) Title: RADIATION AND MELT TREATED ULTRA HIGH MOLECULAR WEIGHT POLYETHYLENE PROSTHETIC  
 DEVICES

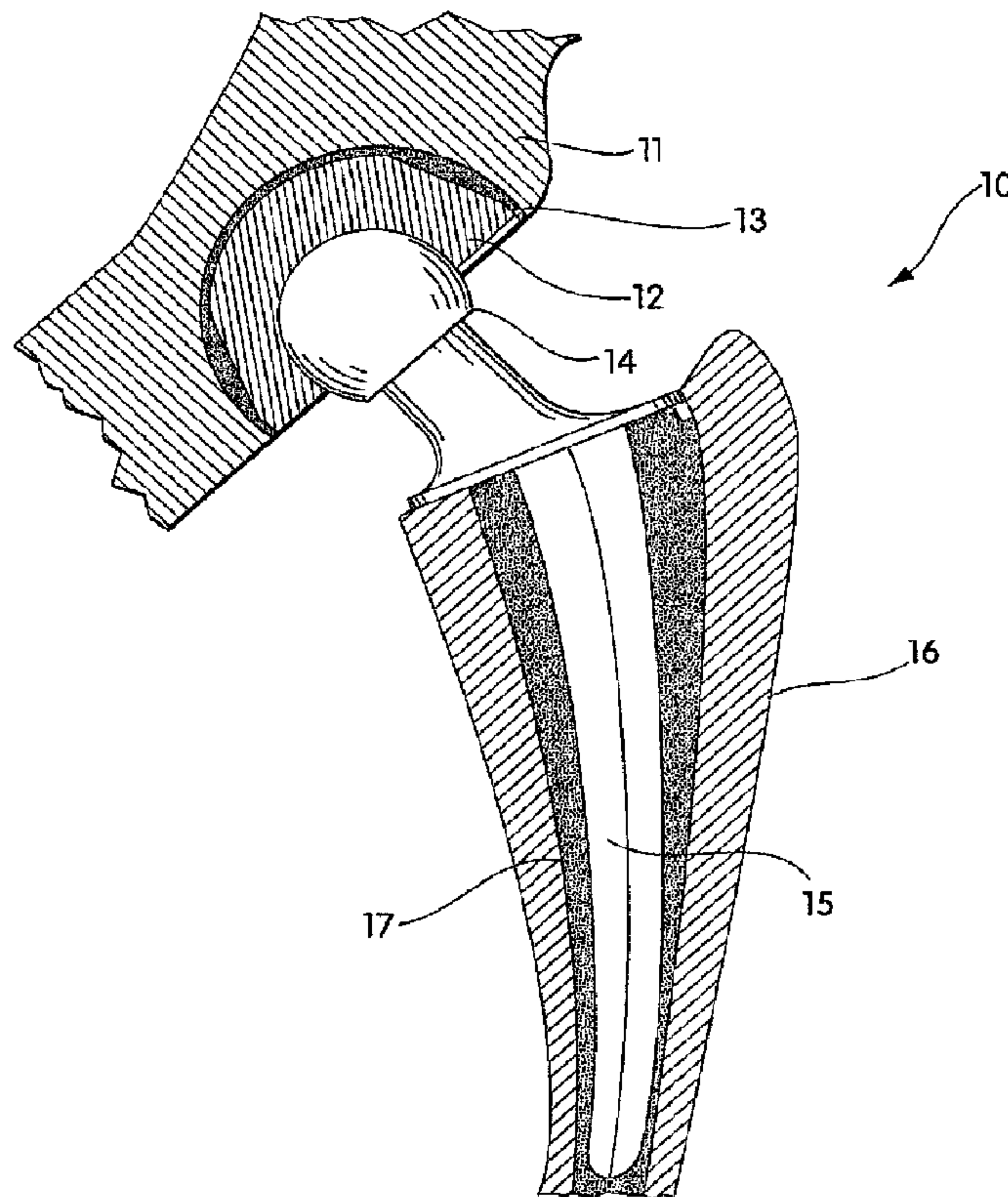

(57) Abrégé/Abstract:

A medical prosthesis for use within the body which is formed of radiation treated ultra high molecular weight polyethylene having substantially no detectable free radicals, is described. Preferred prostheses exhibit reduced production of particles from the prosthesis during wear of the prosthesis, and are substantially oxidation resistant. Methods of manufacture of such devices and material used therein are also provided.

(72) **Inventeurs(suite)/Inventors(continued)**: MURATOGLU, ORHUN, US; BRAGDON, CHARLES R., US;  
O'CONNOR, DANIEL O., US; VENUGOPALAN, PREMNATH, US

(73) **Propriétaires(suite)/Owners(continued)**: MASSACHUSETTS INSTITUTE OF TECHNOLOGY, US;  
THE GENERAL HOSPITAL CORPORATION, US

(74) **Agent**: OGILVY RENAULT LLP/S.E.N.C.R.L., S.R.L.



**RADIATION AND MELT TREATED ULTRA HIGH MOLECULAR WEIGHT  
POLYETHYLENE PROSTHETIC DEVICES**

**FIELD OF THE INVENTION**

5 The present invention relates to the orthopedic field and the provision of prostheses, such as hip and knee implants, as well as methods of manufacture of such devices and material used therein.

**BACKGROUND OF THE INVENTION**

10 The use of synthetic polymers, e.g., ultra high molecular weight polyethylene, with metallic alloys has revolutionized the field of prosthetic implants, e.g., their use in total joint replacements for the hip or knee. Wear of the synthetic polymer against the metal of the articulation, however, can result in  
15 severe adverse effects which predominantly manifest after several years. Various studies have concluded that such wear can lead to the liberation of ultrafine particles of polyethylene into the periprosthetic tissues. It has been suggested that the abrasion stretches the chain folded  
20 crystallites to form anisotropic fibrillar structures at the articulating surface. The stretched-out fibrils can then rupture, leading to production of submicron sized particles. In response to the progressive ingress of these polyethylene particles between the prosthesis and bone, macrophage-induced  
25 resorption of the periprosthetic bone is initiated. The macrophage, often being unable to digest these polyethylene particles, synthesize and release large numbers of cytokines and growth factors which can ultimately result in bone resorption by osteoclasts and monocytes. This osteolysis can contribute to  
30 mechanical loosening of the prosthesis components, thereby sometimes requiring revision surgery with its concomitant problems.

Summary of the Invention

It is an object of the invention to provide an implantable prosthesis device formed at least in part of radiation treated  
5 ultra high molecular weight polyethylene (UHMWPE) having no detectable free radicals, so as to reduce production of fine particles from the prosthesis during wear of the prosthesis.

It is another object of the invention to reduce osteolysis and inflammatory reactions resulting from prosthesis implants.

10 It is yet another object of the invention to provide a prosthesis which can remain implanted within a person for prolonged periods of time.

It is yet another object of the invention to provide improved UHMWPE which can be used in the prostheses of the  
15 preceding objects and/or in other fabricated articles.

Still another object of the invention is to provide improved UHMWPE which has a high density of cross-links and no detectable free radicals.

A still further object of the invention is to provide  
20 improved UHMWPE which has improved wear resistance.

According to the invention, a medical prosthesis for use within the body which is formed of radiation treated ultra high molecular weight polyethylene (UHMWPE) having substantially no detectable free radicals, is provided. The radiation can be,  
25 e.g., gamma or electron radiation. The UHMWPE has a cross-linked structure. Preferably, the UHMWPE is substantially not oxidized and is substantially oxidation resistant. Variations include, e.g., the UHMWPE having three melting peaks, two melting peaks or one melting peak. In certain embodiments,  
30 the UHMWPE has a polymeric structure with less than about 50% crystallinity, less than about 290Å lamellar thickness and less than about 940 MPa tensile elastic modulus, so as to reduce production of fine particles from the prosthesis during wear of the prosthesis. Part of the prosthesis can be, e.g., in the  
35 form of a cup or tray shaped article having a load bearing surface made of this UHMWPE. This load bearing surface can be in contact with a second part of the prosthesis having a mating load bearing surface of a metallic or ceramic material.

Another aspect of the invention is radiation treated UHMWPE

having substantially no detectable free radicals. This UHMWPE has a cross-linked structure. Preferably, this UHMWPE is substantially not oxidized and is substantially oxidation resistant. Variations include, e.g., the UHMWPE having three melting peaks, two melting peaks or one melting peak.

Other aspects of the invention are fabricated articles, e.g., with a load bearing surface, and wear resistant coatings, made from such UHMWPE. One embodiment is where the fabricated article is in the form of a bar stock which is capable of being shaped into articles by conventional methods, e.g., machining.

Yet another aspect of the invention includes a method for making a cross-linked UHMWPE having substantially no detectable free radicals. Conventional UHMWPE having polymeric chains is provided. This UHMWPE is irradiated so as to cross-link said polymeric chains. The UHMWPE is heated above the melting temperature of the UHMWPE so that there are substantially no detectable free radicals in the UHMWPE. The UHMWPE is then cooled to room temperature. In certain embodiments, the cooled UHMWPE is machined and/or sterilized.

One preferred embodiment of this method is called CIR-SM, i.e., cold irradiation and subsequent melting. The UHMWPE that is provided is at room temperature or below room temperature.

Another preferred embodiment of this method is called WIR-SM, i.e., warm irradiation and subsequent melting. The UHMWPE that is provided is pre-heated to a temperature below the melting temperature of the UHMWPE.

Another preferred embodiment of this method is called WIR-AM, i.e., warm irradiation and adiabatic melting. In this embodiment, the UHMWPE that is provided is pre-heated to a temperature below the melting temperature of the UHMWPE, preferably between about 100°C to below the melting temperature of the UHMWPE. Preferably, the UHMWPE is in an insulating material so as to reduce heat loss from the UHMWPE during processing. The pre-heated UHMWPE is then irradiated to a high enough total dose and at a fast enough dose rate so as to generate enough heat in the polymer to melt substantially all the crystals in the material and thus ensure elimination of substantially all detectable free radicals generated by, e.g., the irradiating step. It is preferred that the irradiating step

use electron irradiation so as to generate such adiabatic heating.

Another aspect of this invention is the product made in accordance with the above described method.

5 Yet another aspect of this invention, called MIR, i.e., melt irradiation, is a method for making crosslinked UHMWPE. Conventional UHMWPE is provided. Preferably, the UHMWPE is surrounded with an inert material that is substantially free of oxygen. The UHMWPE is heated above the melting temperature of  
10 the UHMWPE so as to completely melt all crystalline structure. The heated UHMWPE is irradiated, and the irradiated UHMWPE is cooled to about 25°C.

In an embodiment of MIR, highly entangled and crosslinked UHMWPE is made. Conventional UHMWPE is provided. Preferably,  
15 the UHMWPE is surrounded with an inert material that is substantially free of oxygen. The UHMWPE is heated above the melting temperature of the UHMWPE for a time sufficient to enable the formation of entangled polymer chains in the UHMWPE. The heated UHMWPE is irradiated so as to trap the polymer chains  
20 in the entangled state, and the irradiated UHMWPE is cooled to about 25°C.

The invention also features a method of making a medical prosthesis from radiation treated UHMWPE having substantially no detectable free radicals, the prosthesis resulting in reduced  
25 production of particles from the prosthesis during wear of the prosthesis. Radiation treated UHMWPE having no detectable free radicals is provided. A medical prosthesis is formed from this UHMWPE so as to reduce production of particles from the prosthesis during wear of the prosthesis, the UHMWPE forming a  
30 load bearing surface of the prosthesis. Formation of the prosthesis can be accomplished by standard procedures known to those skilled in the art, e.g., machining.

Also provided in this invention is a method of treating a body in need of a medical prosthesis. A shaped prosthesis  
35 formed of radiation treated UHMWPE having substantially no detectable free radicals is provided. The prosthesis is applied to the body in need of the prosthesis. The prosthesis reduces production of particles from the prosthesis during wear of the prosthesis. In preferred embodiments, the UHMWPE forms a load

bearing surface of the prosthesis.

The above and other objects, features and advantages of the present invention will be better understood from the following specification when read in conjunction with the accompanying  
5 drawings.

#### Brief Description of the Drawings

FIG. 1 is a cross-sectional view through the center of a medical hip joint prosthesis in accordance with a preferred  
10 embodiment of this invention;

FIG. 2 is a side view of an acetabular cup liner as shown in FIG. 1;

FIG. 3 is a cross-sectional view through line 3-3 of FIG.  
2;

15 FIG. 4 is a graph showing the crystallinity and melting point of melt-irradiated UHMWPE at different irradiation doses;

FIG. 5 is an environmental scanning electron micrograph of an etched surface of conventional UHMWPE showing its crystalline structure;

20 FIG. 6 is an environmental scanning electron micrograph of an etched surface of melt-irradiated UHMWPE showing its crystalline structure at approximately the same magnification as in FIG. 5; and

FIG. 7 is a graph showing the crystallinity and melting  
25 point at different depths of a melt-irradiated UHMWPE cup.

FIG. 8 is a graph showing DSC melting endotherms for Hoechst-Celanese GUR 4050 UHMWPE prepared using warm irradiation and partial adiabatic melting (WIR-AM), with and without subsequent heating.

30 FIG. 9 is a graph showing DSC melting endotherms for Hoechst-Celanese GUR 1050 UHMWPE prepared using warm irradiation and partial adiabatic melting (WIR-AM), with and without subsequent heating.

FIG. 10 is a graph showing adiabatic heating of UHMWPE  
35 treated by WIR-AM with a pre-heat temperature of 130°C.

FIG. 11 is a graph showing tensile deformation behavior of unirradiated UHMWPE, CIR-SM treated UHMWPE, and WIR-AM treated UHMWPE.

Detailed Description

This invention provides a medical prosthesis for use within the body which is formed of radiation treated ultra high molecular weight polyethylene (UHMWPE) which has substantially  
5 no detectable free radicals.

A medical prosthesis in the form of a hip joint prosthesis is generally illustrated at 10 in FIG. 1. The prosthesis shown has a conventional ball head 14 connected by a neck portion to a stem 15 which is mounted by conventional cement 17 to the femur  
10 16. The ball head can be of conventional design and formed of stainless steel or other alloys as known in the art. The radius of the ball head closely conforms to the inner cup radius of an acetabular cup 12 which can be mounted in cement 13 directly to the pelvis 11. Alternatively, a metallic acetabular shell can  
15 be cemented to the pelvis 11 and the acetabular cup 12 can form a coating or liner connected to the metallic acetabular shell by means as are known in the art.

The specific form of the prosthesis can vary greatly as known in the art. Many hip joint constructions are known and  
20 other prostheses such as knee joints, shoulder joints, ankle joints, elbow joints and finger joints are known. All such prior art prostheses can be benefited by making at least one load bearing surface of such prosthesis of a high molecular weight polyethylene material in accordance with this invention.  
25 Such load bearing surfaces can be in the form of layers, linings or actual whole devices as shown in FIG. 1. In all cases, it is preferred that the load bearing surface act in conjunction with a metallic or ceramic mating member of the prosthesis so that a sliding surface is formed therebetween. Such sliding surfaces  
30 are subject to breakdown of the polyethylene as known in the prior art. Such breakdown can be greatly diminished by use of the materials of the present invention.

FIG. 2 shows the acetabular cup 12 in the form of a half hollow ball-shaped device better seen in the cross-section of  
35 FIG. 3. As previously described, the outer surface 20 of the acetabular cup need not be circular or hemispherical but can be square or of any configuration to be adhered directly to the pelvis or to the pelvis through a metallic shell as known in the art. The radius of the acetabular cup shown at 21 in FIG. 3 of

-7-

the preferred embodiment ranges from about 20 mm to about 35 mm. The thickness of the acetabular cup from its generally hemispherical hollow portion to the outer surface 20 is preferably about 8 mm. The outer radius is preferably in the  
5 order of about 20 mm to about 35 mm.

In some cases, the ball joint can be made of the UHMWPE of this invention and the acetabular cup formed of metal, although it is preferred to make the acetabular cup or acetabular cup liner of UHMWPE to mate with the metallic ball. The particular  
10 method of attachment of the components of the prosthesis to the bones of the body can vary greatly as known in the art.

The medical prosthesis of this invention is meant to include whole prosthetic devices or portions thereof, e.g., a component, layer or lining. The medical prosthesis includes,  
15 e.g., orthopedic joint and bone replacement parts, e.g., hip, knee, shoulder, elbow, ankle or finger replacements. The prosthesis can be in the form, e.g., of a cup or tray shaped article which has a load bearing surface. Other forms known to those skilled in the art are also included in the invention.  
20 Medical prostheses are also meant to include any wearing surface of a prosthesis, e.g., a coating on a surface of a prosthesis in which the prosthesis is made from a material other than the UHMWPE of this invention.

The prostheses of this invention are useful for contact  
25 with metal containing parts formed of, e.g., cobalt chromium alloy, stainless steel, titanium alloy or nickel cobalt alloy, or with ceramic containing parts. For example, a hip joint is constructed in which a cup shaped article having an inner radius of 25 mm, is contacted with a metal ball having an outer radius  
30 of 25 mm, so as to closely mate with the cup shaped article. The load bearing surface of the cup shaped article of this example is made from the UHMWPE of this invention, preferably having a thickness of at least about 1 mm, more preferably having a thickness of at least about 2 mm, more preferably  
35 having a thickness of at least about ¼ inch, and more preferably yet having a thickness of at least about ⅓ inch.

The prostheses can have any standard known form, shape, or configuration, or be a custom design, but have at least one load bearing surface of UHMWPE of this invention.

-8-

The prostheses of this invention are non-toxic to humans. They are not subject to deterioration by normal body constituents, e.g., blood or interstitial fluids. They are capable of being sterilized by standard means, including, e.g.,  
5 heat or ethylene oxide.

By UHMWPE is meant linear non-branched chains of ethylene that have molecular weights in excess of about 500,000, preferably above about 1,000,000, and more preferably above about 2,000,000. Often the molecular weights can be at least as  
10 high as about 8,000,000. By initial average molecular weight is meant the average molecular weight of the UHMWPE starting material, prior to any irradiation.

Conventional UHMWPE is standardly generated by Ziegler-Natta catalysis, and as the polymer chains are generated  
15 from the surface catalytic site, they crystallize, and interlock as chain folded crystals. Examples of known UHMWPE powders include Hifax Grade 1900 polyethylene (obtained from Montell, Wilmington, Delaware), having a molecular weight of about 2 million g/mol and not containing any calcium stearate; GUR 4150,  
20 also known as GUR 415, (obtained from Hoescht Celanese Corp., Houston, TX), having a molecular weight of about 4-5 million g/mol and containing 500 ppm of calcium stearate; GUR 4050 (obtained from Hoescht Celanese Corp., Houston, TX), having a molecular weight of about 4-5 million g/mol and not containing  
25 any calcium stearate; GUR 4120 (obtained from Hoescht Celanese Corp., Houston, TX), having a molecular weight of about 2 million g/mol and containing 500 ppm of calcium stearate; GUR 4020 (obtained from Hoescht Celanese Corp., Houston, TX), having a molecular weight of about 2 million g/mol and not containing  
30 any calcium stearate; GUR 1050 (obtained from Hoescht Celanese Corp., Germany), having a molecular weight of about 4-5 million g/mol and not containing any calcium stearate; GUR 1150 (obtained from Hoescht Celanese Corp., Germany), having a molecular weight of about 4-5 million g/mol and containing 500  
35 ppm of calcium stearate; GUR 1020 (obtained from Hoescht Celanese Corp., Germany), having a molecular weight of about 2 million g/mol and not containing any calcium stearate; and GUR 1120 (obtained from Hoescht Celanese Corp., Germany), having a molecular weight of about 2 million g/mol and containing 500 ppm

of calcium stearate. Preferred UHMWPEs for medical applications are GUR 4150, GUR 1050 and GUR 1020. By resin is meant powder.

UHMWPE powder can be consolidated using a variety of different techniques, e.g., ram extrusion, compression molding or direct compression molding. In ram extrusion, the UHMWPE powder is pressurized through a heated barrel whereby it is consolidated into a rod stock, i.e., bar stock (can be obtained, e.g., from Westlake Plastics, Lenni, PA). In compression molding, the UHMWPE powder is consolidated under high pressure into a mold (can be obtained, e.g., from Poly-Hi Solidur, Fort Wayne, IN, or Perplas, Stanmore, U.K.). The shape of the mold can be, e.g., a thick sheet. Direct compression molding is preferably used to manufacture net shaped products, e.g., acetabular components or tibial knee inserts (can be obtained, e.g., from Zimmer, Inc., Warsaw, IN). In this technique, the UHMWPE powder is compressed directly into the final shape. "Hockey pucks", or pucks, are generally machined from ram extruded bar stock or from a compression molded sheet.

By radiation treated UHMWPE is meant UHMWPE which has been treated with radiation, e.g., gamma radiation or electron radiation, so as to induce cross-links between the polymeric chains of the UHMWPE.

By substantially no detectable free radicals is meant substantially no free radicals as measured by electron paramagnetic resonance, as described in Jahan et al., J. Biomedical Materials Research 25:1005 (1991). Free radicals include, e.g., unsaturated trans-vinylene free radicals. UHMWPE that has been irradiated below its melting point with ionizing radiation contains cross-links as well as long-lived trapped free radicals. These free radicals react with oxygen over the long-term and result in the embrittlement of the UHMWPE through oxidative degradation. An advantage of the UHMWPE and medical prostheses of this invention is that radiation treated UHMWPE is used which has no detectable free radicals. The free radicals can be eliminated by any method which gives this result, e.g., by heating the UHMWPE above its melting point such that substantially no residual crystalline structure remains. By eliminating the crystalline structure, the free radicals are able to recombine and thus are eliminated.

-10-

The UHMWPE which is used in this invention has a cross-linked structure. An advantage of having a cross-linked structure is that it will reduce production of particles from the prosthesis during wear of the prosthesis.

5 It is preferred that the UHMWPE be substantially not oxidized. By substantially not oxidized is meant that the ratio of the area under the carbonyl peak at  $1740\text{ cm}^{-1}$  in the FTIR spectra to the area under the peak at  $1460\text{ cm}^{-1}$  in the FTIR spectra of the cross-linked sample be of the same order of  
10 magnitude as the ratio for the sample before cross-linking.

It is preferred that the UHMWPE be substantially oxidation resistant. By substantially oxidation resistant is meant that it remains substantially not oxidized for at least about 10 years. Preferably, it remains substantially not oxidized for at  
15 least about 20 years, more preferably for at least about 30 years, more preferably yet for at least about 40 years, and most preferably for the entire lifetime of the patient.

In certain embodiments, the UHMWPE has three melting peaks. The first melting peak preferably is about  $105^{\circ}\text{C}$  to about  $120^{\circ}\text{C}$ ,  
20 more preferably is about  $110^{\circ}\text{C}$  to about  $120^{\circ}\text{C}$ , and most preferably is about  $118^{\circ}\text{C}$ . The second melting peak preferably is about  $125^{\circ}\text{C}$  to about  $140^{\circ}\text{C}$ , more preferably is about  $130^{\circ}\text{C}$  to about  $140^{\circ}\text{C}$ , more preferably yet is about  $135^{\circ}\text{C}$ , and most preferably is about  $137^{\circ}\text{C}$ . The third melting peak preferably is  
25 about  $140^{\circ}\text{C}$  to about  $150^{\circ}\text{C}$ , more preferably is about  $140^{\circ}\text{C}$  to about  $145^{\circ}\text{C}$ , and most preferably is about  $144^{\circ}\text{C}$ . In certain embodiments, the UHMWPE has two melting peaks. The first melting peak preferably is about  $105^{\circ}\text{C}$  to about  $120^{\circ}\text{C}$ , more preferably is about  $110^{\circ}\text{C}$  to about  $120^{\circ}\text{C}$ , and most preferably is  
30 about  $118^{\circ}\text{C}$ . The second melting peak preferably is about  $125^{\circ}\text{C}$  to about  $140^{\circ}\text{C}$ , more preferably is about  $130^{\circ}\text{C}$  to about  $140^{\circ}\text{C}$ , more preferably yet is about  $135^{\circ}\text{C}$ , and most preferably is about  $137^{\circ}\text{C}$ . In certain embodiments, the UHMWPE has one melting peak. The melting peak preferably is about  $125^{\circ}\text{C}$  to about  $140^{\circ}\text{C}$ , more  
35 preferably is about  $130^{\circ}\text{C}$  to about  $140^{\circ}\text{C}$ , more preferably yet is about  $135^{\circ}\text{C}$ , and most preferably is about  $137^{\circ}\text{C}$ . Preferably, the UHMWPE has two melting peaks. The number of melting peaks is determined by differential scanning calorimetry (DSC) at a heating rate of  $10^{\circ}\text{C}/\text{min}$ .

-11-

The polymeric structure of the UHMWPE used in the prostheses of this invention results in the reduction of production of UHMWPE particles from the prosthesis during wear of the prosthesis. As a result of the limited number of particles being shed into the body, the prosthesis exhibits longer implant life. Preferably, the prosthesis can remain implanted in the body for at least 10 years, more preferably for at least 20 years and most preferably for the entire lifetime of the patient.

The invention also includes other fabricated articles made from radiation treated UHMWPE having substantially no detectable free radicals. Preferably, the UHMWPE which is used for making the fabricated articles has a cross-linked structure. Preferably, the UHMWPE is substantially oxidation resistant. In certain embodiments, the UHMWPE has three melting peaks. In certain embodiments, the UHMWPE has two melting peaks. In certain embodiments, the UHMWPE has one melting peak. Preferably, the UHMWPE has two melting peaks. The fabricated articles include shaped articles and unshaped articles, including, e.g., machined objects, e.g., cups, gears, nuts, sled runners, bolts, fasteners, cables, pipes and the like, and bar stock, films, cylindrical bars, sheeting, panels, and fibers. Shaped articles can be made, e.g., by machining. The fabricated article can be, e.g., in the form of a bar stock which is capable of being shaped into a second article by machining. The fabricated articles are particularly suitable for load bearing applications, e.g., high wear resistance applications, e.g., as a load bearing surface, e.g., an articulating surface, and as metal replacement articles. Thin films or sheets of the UHMWPE of this invention can also be attached, e.g., with glue, onto supporting surfaces, and thus used as a wear resistant load bearing surface.

The invention also includes radiation treated UHMWPE which has substantially no detectable free radicals. The UHMWPE has a cross-linked structure. Preferably, the UHMWPE is substantially not oxidized and is substantially oxidation resistant. In certain embodiments, the UHMWPE has three melting peaks. In certain embodiments, the UHMWPE has two melting peaks. In certain embodiments, the UHMWPE has one melting peak.

-12-

Preferably, the UHMWPE has two melting peaks. Depending upon the particular processing used to make the UHMWPE, certain impurities may be present in the UHMWPE of this invention, including, e.g., calcium stearate, mold release agents, extenders, anti-oxidants and/or other conventional additives to polyethylene polymers.

The invention also provides a method for making cross-linked UHMWPE having substantially no detectable free radicals. Preferably, this UHMWPE is for use as a load bearing article with high wear resistance. Conventional UHMWPE having polymeric chains is provided. The conventional UHMWPE can be in the form of, e.g., a bar stock, a shaped bar stock, e.g., a puck, a coating, or a fabricated article, e.g., a cup or tray shaped article for use in a medical prosthesis. By conventional UHMWPE is meant commercially available high density (linear) polyethylene of molecular weights greater than about 500,000. Preferably, the UHMWPE starting material has an average molecular weight of greater than about 2 million. By initial average molecular weight is meant the average molecular weight of the UHMWPE starting material, prior to any irradiation. The UHMWPE is irradiated so as to cross-link the polymeric chains. The irradiation can be done in an inert or non-inert environment. Preferably, the irradiation is done in a non-inert environment, e.g., air. The irradiated UHMWPE is heated above the melting temperature of the UHMWPE so that there are substantially no detectable free radicals in the UHMWPE. The heated UHMWPE is then cooled to room temperature. Preferably, the cooling step is at a rate greater than about 0.1°C/minute. Optionally, the cooled UHMWPE can be machined. For example, if any oxidation of the UHMWPE occurred during the irradiating step, it can be machined away if desired, by any method known to those skilled in the art. And optionally, the cooled UHMWPE, or the machined UHMWPE, can be sterilized by any method known to those skilled in the art.

One preferred embodiment of this method is called CIR-SM, i.e., cold irradiation and subsequent melting. In this embodiment, the UHMWPE that is provided is at room temperature or below room temperature. Preferably, it is about 20°C. Irradiation of the UHMWPE can be with, e.g., gamma irradiation

or electron irradiation. In general, gamma irradiation gives a high penetration depth but takes a longer time, resulting in the possibility of more in-depth oxidation. In general, electron irradiation gives more limited penetration depths but takes a shorter time, and the possibility of extensive oxidation is reduced. The irradiation is done so as to cross-link the polymeric chains. The irradiation dose can be varied to control the degree of cross-linking and crystallinity in the final UHMWPE product. Preferably, the total absorbed dose of the irradiation is about 0.5 to about 1,000 Mrad, more preferably about 1 to about 100 Mrad, more preferably yet about 4 to about 30 Mrad, more preferably yet about 20 Mrad, and most preferably about 15 Mrad. Preferably, a dose rate is used that does not generate enough heat to melt the UHMWPE. If gamma irradiation is used, the preferred dose rate is about 0.05 to about 0.2 Mrad/minute. If electron irradiation is used, preferably the dose rate is about 0.05 to about 3,000 Mrad/minute, more preferably about 0.05 to about 5 Mrad/minute, and most preferably about 0.05 to about 0.2 Mrad/minute. The dose rate in electron irradiation is determined by the following parameters: (i) the power of the accelerator in kW, (ii) the conveyor speed, (iii) the distance between the surface of the irradiated specimen and the scan horn, and (iv) the scan width. The dose rate at an e-beam facility is often measured in Mrads per pass under the rastering e-beam. The dose rates indicated herein as Mrad/minute can be converted to Mrad/pass by using the following equation:

$$D_{\text{Mrad/min}} = D_{\text{Mrad/pass}} \times v_c \div l$$

where  $D_{\text{Mrad/min}}$  is the dose rate in Mrad/min,  $D_{\text{Mrad/pass}}$  is the dose rate in Mrad/pass,  $v_c$  is the conveyor speed and  $l$  is the length of the specimen that travels through the e-beam raster area. When electron irradiation is used, the energy of the electrons can be varied to change the depth of penetration of the electrons. Preferably, the energy of the electrons is about 0.5 MeV to about 12 MeV, more preferably about 5 MeV to about 12 MeV. Such manipulability is particularly useful when the irradiated object is an article of varying thickness or depth,

-14-

e.g., an articular cup for a medical prosthesis.

The irradiated UHMWPE is heated above the melting temperature of the UHMWPE so that there are no detectable free radicals in the UHMWPE. The heating provides the molecules with sufficient mobility so as to eliminate the constraints derived from the crystals of the UHMWPE, thereby allowing essentially all of the residual free radicals to recombine. Preferably, the UHMWPE is heated to a temperature of about 137°C to about 300°C, more preferably about 140°C to about 300°C, more preferably yet about 140°C to about 190°C, more preferably yet about 145°C to about 300°C, more preferably yet about 145°C to about 190°C, more preferably yet about 146°C to about 190°C, and most preferably about 150°C. Preferably, the temperature in the heating step is maintained for about 0.5 minutes to about 24 hours, more preferably about 1 hour to about 3 hours, and most preferably about 2 hours. The heating can be carried out, e.g., in air, in an inert gas, e.g., nitrogen, argon or helium, in a sensitizing atmosphere, e.g., acetylene, or in a vacuum. It is preferred that for the longer heating times, that the heating be carried out in an inert gas or under vacuum.

Another preferred embodiment of this method is called WIR-SM, i.e., warm irradiation and subsequent melting. In this embodiment, the UHMWPE that is provided is pre-heated to a temperature below the melting temperature of the UHMWPE. The pre-heating can be done in an inert or non-inert environment. It is preferred that this pre-heating is done in air. Preferably, the UHMWPE is pre-heated to a temperature of about 20°C to about 135°C, more preferably to a temperature greater than about 20°C to about 135°C, and most preferably to a temperature of about 50°C. The other parameters are as described above for the CIR-SM embodiment, except that the dose rate for the irradiating step using electron irradiation is preferably about 0.05 to about 10 Mrad/minute, and more preferably is about 4 to about 5 Mrad/minute; and the dose rate for the irradiating step using gamma irradiation is preferably about 0.05 to about 0.2 Mrad/minute, and more preferably is about 0.2 Mrad/minute.

Another preferred embodiment of this method is called WIR-AM, i.e., warm irradiation and adiabatic melting. In this

-15-

embodiment, the UHMWPE that is provided is pre-heated to a temperature below the melting temperature of the UHMWPE. The pre-heating can be done in an inert or non-inert environment. It is preferred that this pre-heating is done in air. The pre-heating can be done, e.g., in an oven. It is preferred that the pre-heating is to a temperature between about 100°C to below the melting temperature of the UHMWPE. Preferably, the UHMWPE is pre-heated to a temperature of about 100°C to about 135°C, more preferably the temperature is about 130°C, and most preferably is about 120°C. Preferably, the UHMWPE is in an insulating material so as to reduce heat loss from the UHMWPE during processing. The heat is meant to include, e.g., the pre-heat delivered before irradiation and the heat generated during irradiation. By insulating material is meant any type of material which has insulating properties, e.g., a fiberglass pouch.

The pre-heated UHMWPE is then irradiated to a high enough total dose and at a fast enough dose rate so as to generate enough heat in the polymer to melt substantially all the crystals in the material and thus ensure elimination of substantially all detectable free radicals generated by, e.g., the irradiating step. It is preferred that the irradiating step use electron irradiation so as to generate such adiabatic heating. By adiabatic heating is meant no loss of heat to the surroundings during irradiation. Adiabatic heating results in adiabatic melting if the temperature is above the melting point. Adiabatic melting is meant to include complete or partial melting. The minimum total dose is determined by the amount of heat necessary to heat the polymer from its initial temperature (i.e., the pre-heated temperature discussed above) to its melting temperature, and the heat necessary to melt all the crystals, and the heat necessary to heat the polymer to a pre-determined temperature above its melting point. The following equation describes how the amount of total dose is calculated:

$$\text{Total Dose} = c_{p_s} (T_m - T_i) + \Delta H_m + c_{p_m} (T_f - T_m)$$

where  $c_{p_s}$  (= 2 J/g/°C) and  $c_{p_m}$  (= 3 J/g/°C) are heat

-16-

capacities of UHMWPE in the solid state and melt state, respectively,  $\Delta H_m$  (= 146 J/g) is the heat of melting of the unirradiated Hoescht Celanese GUR 415 bar stock,  $T_i$  is the initial temperature, and  $T_f$  is the final temperature. The final  
5 temperature should be above the melting temperature of the UHMWPE.

Preferably, the final temperature of the UHMWPE is about 140°C to about 200°C, more preferably it is about 145°C to about 190°C, more preferably yet it is about 146°C to about 190°C, and  
10 most preferably it is about 150°C. At above 160°C, the polymer starts to form bubbles and cracks. Preferably, the dose rate of the electron irradiation is about 2 to about 3,000 Mrad/minute, more preferably yet is about 2 to about 30 Mrad/minute, more preferably yet is about 7 to about 25 Mrad/minute, more  
15 preferably yet is about 20 Mrad/minute, and most preferably is about 7 Mrad/minute. Preferably, the total absorbed dose is about 1 to about 100 Mrad. Using the above equation, the absorbed dose for an initial temperature of 130°C and a final temperature of 150°C is calculated to be about 22 Mrad.

20 In this embodiment, the heating step of the method results from the adiabatic heating described above.

In certain embodiments, the adiabatic heating completely melts the UHMWPE. In certain embodiments, the adiabatic heating only partially melts the UHMWPE. Preferably, additional heating  
25 of the irradiated UHMWPE is done subsequent to the irradiation induced adiabatic heating so that the final temperature of the UHMWPE after the additional heating is above the melting temperature of the UHMWPE, so as to ensure complete melting of the UHMWPE. Preferably, the temperature of the UHMWPE from the  
30 additional heating is about 140°C to about 200°C, more preferably is about 145°C to about 190°C, more preferably yet is about 146°C to about 190°C, and most preferably is about 150°C.

Yet another embodiment of this invention is called CIR-AM, i.e., cold irradiation and adiabatic heating. In this  
35 embodiment, UHMWPE at room temperature or below room temperature is melted by adiabatic heating, with or without subsequent additional heating, as described above.

This invention also includes the product made in accordance with the above described method.

Also provided in this invention is a method of making a medical prosthesis from UHMWPE having substantially no detectable free radicals, the prosthesis resulting in the reduced production of particles from the prosthesis during wear of the prosthesis. Radiation treated UHMWPE having no detectable free radicals is provided. A medical prosthesis is formed from this UHMWPE so as to reduce production of particles from the prosthesis during wear of the prosthesis, the UHMWPE forming a load bearing surface of the prosthesis. Formation of the prosthesis can be accomplished by standard procedures known to those skilled in the art, e.g., machining.

Also provided in this invention is a method of treating a body in need of a medical prosthesis. A shaped prosthesis formed of radiation treated UHMWPE having substantially no detectable free radicals is provided. This prosthesis is applied to the body in need of the prosthesis. The prosthesis reduces production of fine particles from the prosthesis during wear of the prosthesis. In preferred embodiments, the ultra high molecular weight polyethylene forms a load bearing surface of the prosthesis.

In yet another embodiment of this invention, a medical prosthesis for use within the body which is formed of ultra high molecular weight polyethylene (UHMWPE) which has a polymeric structure with less than about 50% crystallinity, less than about 290Å lamellar thickness and less than about 940 MPa tensile elastic modulus, so as to reduce production of fine particles from the prosthesis during wear of the prosthesis, is provided.

The UHMWPE of this embodiment has a polymeric structure with less than about 50% crystallinity, preferably less than about 40% crystallinity. By crystallinity is meant the fraction of the polymer that is crystalline. The crystallinity is calculated by knowing the weight of the sample ( $w$ , in g), the heat absorbed by the sample in melting ( $E$ , in cal) and the calculated heat of melting of polyethylene in the 100% crystalline state ( $\Delta H^\circ = 69.2$  cal/g), and using the following equation:

$$\% \text{ crystallinity} = \frac{E}{w \cdot \Delta H^\circ}$$

-18-

The UHMWPE of this embodiment has a polymeric structure with less than about 290Å lamellar thickness, preferably less than about 200Å lamellar thickness, and most preferably less than about 100Å lamellar thickness. By lamellar thickness (l) is meant the calculated thickness of assumed lamellar structures in the polymer using the following expression:

$$l = \frac{2 \cdot \sigma_e \cdot T_m^\circ}{\Delta H^\circ \cdot (T_m^\circ - T_m) \cdot \rho}$$

where,  $\sigma_e$  is the end free surface energy of polyethylene ( $2.22 \times 10^{-6}$  cal/cm<sup>2</sup>),  $\Delta H^\circ$  is the calculated heat of melting of polyethylene in the 100% crystalline state (69.2 cal/g),  $\rho$  is the density of the crystalline regions (1.005 g/cm<sup>3</sup>),  $T_m^\circ$  is the melting point of a perfect polyethylene crystal (418.15K) and  $T_m$  is the experimentally determined melting point of the sample.

The UHMWPE of this embodiment has less than about 940 MPa tensile elastic modulus, preferably less than about 600 MPa tensile elastic modulus, more preferably less than about 400 MPa tensile elastic modulus, and most preferably less than about 200 MPa tensile elastic modulus. By tensile elastic modulus is meant the ratio of the nominal stress to corresponding strain for strains less than 0.5% as determined using the standard test ASTM 638 M III.

Preferably, the UHMWPE of this embodiment has a polymeric structure with about 40% crystallinity, about 100Å lamellar thickness and about 200 MPa tensile elastic modulus.

The UHMWPE of this embodiment has no trapped free radicals, e.g., unsaturated trans-vinylene free radicals. It is preferred that the UHMWPE of this embodiment have a hardness less than about 65 on the Shore D scale, more preferably a hardness less than about 55 on the Shore D scale, most preferably a hardness less than about 50 on the Shore D scale. By hardness is meant the instantaneous indentation hardness measured on the Shore D scale using a durometer described in ASTM D2240. It is preferred that the UHMWPE of this embodiment be substantially not oxidized. The polymeric structure has extensive cross-linking such that a substantial portion of the polymeric structure does not dissolve in Decalin. By substantial portion

-19-

is meant at least 50% of the polymer sample's dry weight. By not dissolve in Decalin is meant does not dissolve in Decalin at 150°C over a period of 24 hours. Preferably, the UHMWPE of this embodiment has a high density of entanglement so as to cause the formation of imperfect crystals and reduce crystallinity. By the density of entanglement is meant the number of points of entanglement of polymer chains in a unit volume; a higher density of entanglement being indicated by the polymer sample's inability to crystallize to the same extent as conventional UHMWPE, thus leading to a lesser degree of crystallinity.

The invention also includes other fabricated articles made from the UHMWPE of this embodiment having a polymeric structure with less than about 50% crystallinity, less than about 290Å lamellar thickness and less than about 940 MPa tensile elastic modulus. Such articles include shaped articles and unshaped articles, including, e.g., machined objects, e.g., cups, gears, nuts, sled runners, bolts, fasteners, cables, pipes and the like, and bar stock, films, cylindrical bars, sheeting, panels, and fibers. Shaped articles can be made, e.g., by machining. The fabricated articles are particularly suitable for load bearing applications, e.g., as a load bearing surface, and as metal replacement articles. Thin films or sheets of UHMWPE, which have been melt-irradiated can also be attached, e.g., with glue, onto supporting surfaces, and thus used as a transparent, wear resistant load bearing surface.

The invention also includes an embodiment in which UHMWPE has a unique polymeric structure characterized by less than about 50% crystallinity, less than about 290Å lamellar thickness and less than about 940 MPa tensile elastic modulus. Depending upon the particular processing used to make the UHMWPE, certain impurities may be present in the UHMWPE of this invention, including, e.g., calcium stearate, mold release agents, extenders, anti-oxidants and/or other conventional additives to polyethylene polymers. In certain embodiments, the UHMWPE has high transmissivity of light, preferably a transmission greater than about 10% of light at 517 nm through a 1 mm thick sample, more preferably a transmission greater than about 30% of light at 517 nm through a 1 mm thick sample, and most preferably a transmission greater than about 40% of light at 517 nm through a

-20-

1 mm thick sample. Such UHMWPE is particularly useful for thin films or sheets which can be attached onto supporting surfaces of various articles, the film or sheet being transparent and wear resistant.

5 In another embodiment of this invention, a method for making crosslinked UHMWPE is provided. This method is called melt irradiation (MIR). Conventional UHMWPE is provided. Preferably, the UHMWPE is surrounded with an inert material that is substantially free of oxygen. The UHMWPE is heated above the  
10 melting temperature of the UHMWPE so as to completely melt all crystalline structure. The heated UHMWPE is irradiated, and the irradiated UHMWPE is cooled to about 25°C.

Preferably, the UHMWPE made from this embodiment has a polymeric structure with less than about 50% crystallinity, less  
15 than about 290Å lamellar thickness and less than about 940 MPa tensile elastic modulus. Conventional UHMWPE, e.g., a bar stock, a shaped bar stock, a coating, or a fabricated article is provided. By conventional UHMWPE is meant commercially available high density (linear) polyethylene of molecular  
20 weights greater than about 500,000. Preferably, the UHMWPE starting material has an average molecular weight of greater than about 2 million. By initial average molecular weight is meant the average molecular weight of the UHMWPE starting material, prior to any irradiation. It is preferred that this  
25 UHMWPE is surrounded with an inert material that is substantially free of oxygen, e.g., nitrogen, argon or helium. In certain embodiments, a non-inert environment can be used. The UHMWPE is heated above its melting temperature for a time sufficient to allow all the crystals to melt. Preferably, the  
30 temperature is about 145°C to about 230°C, and more preferably, is about 175° to about 200°C. Preferably, the heating is maintained so to keep the polymer at the preferred temperature for about 5 minutes to about 3 hours, and more preferably for about 30 minutes to about 2 hours. The UHMWPE is then  
35 irradiated with gamma irradiation or electron irradiation. In general, gamma irradiation gives a high penetration depth but takes a longer time, resulting in the possibility of some oxidation. In general, electron irradiation gives more limited penetration depths but takes a shorter time, and hence the

-21-

possibility of oxidation is reduced. The irradiation dose can be varied to control the degree of crosslinking and crystallinity in the final UHMWPE product. Preferably, a dose of greater than about 1 Mrad is used, more preferably a dose of greater than about 20 Mrad is used. When electron irradiation is used, the energy of the electrons can be varied to change the depth of penetration of the electrons, thereby controlling the degree of crosslinking and crystallinity in the final UHMWPE product. Preferably, the energy is about 0.5 MeV to about 12 MeV, more preferably about 1 MeV to about 10 MeV, and most preferably about 10 MeV. Such manipulability is particularly useful when the irradiated object is an article of varying thickness or depth, e.g., an articular cup for a prosthesis. The irradiated UHMWPE is then cooled to about 25°C. Preferably, the cooling rate is equal to or greater than about 0.5°C/min, more preferably equal to or greater than about 20°C/min. In certain embodiments, the cooled UHMWPE can be machined. In preferred embodiments, the cooled irradiated UHMWPE has substantially no detectable free radicals. Examples 1, 3 and 6 describe certain preferred embodiments of the method. Examples 2, 4 and 5, and FIGS. 4 through 7, illustrate certain properties of the melt-irradiated UHMWPE obtained from these preferred embodiments, as compared to conventional UHMWPE.

This invention also includes the product made in accordance with the above described method.

In an embodiment of MIR, highly entangled and crosslinked UHMWPE is made. Conventional UHMWPE is provided. Preferably, the UHMWPE is surrounded with an inert material that is substantially free of oxygen. The UHMWPE is heated above the melting temperature of the UHMWPE for a time sufficient to enable the formation of entangled polymer chains in the UHMWPE. The heated UHMWPE is irradiated so as to trap the polymer chains in the entangled state. The irradiated UHMWPE is cooled to about 25°C.

This invention also includes the product made in accordance with the above described method.

Also provided in this invention is a method of making a prosthesis from UHMWPE so as to reduce production of fine particles from the prosthesis during wear of the prosthesis.

-22-

UHMWPE having a polymeric structure with less than about 50% crystallinity, less than about 290Å lamellar thickness and less than about 940 MPa tensile elastic modulus is provided. A prosthesis is formed from this UHMWPE, the UHMWPE forming a load bearing surface of the prosthesis. Formation of the prosthesis can be accomplished by standard procedures known to those skilled in the art, e.g., machining.

Also provided in this invention is a method of treating a body in need of a prosthesis. A shaped prosthesis formed of ultra high molecular weight polyethylene having a polymeric structure with less than about 50% crystallinity, less than about 290Å lamellar thickness and less than about 940 MPa tensile elastic modulus, is provided. This prosthesis is applied to the body in need of the prosthesis. The prosthesis reduces production of fine particles from the prosthesis during wear of the prosthesis. In preferred embodiments, the ultra high molecular weight polyethylene forms a load bearing surface of the prosthesis.

The products and processes of this invention also apply to other polymeric materials such as high-density-polyethylene, low-density-polyethylene, linear-low-density-polyethylene and polypropylene.

The following non-limiting examples further illustrate the present invention.

#### EXAMPLES

##### Example 1: Method of Making Melt-Irradiated UHMWPE (MIR)

This example illustrates electron irradiation of melted UHMWPE.

A cuboidal specimen (puck) of size 10 mm x 12 mm x 60 mm, prepared from conventional ram extruded UHMWPE bar stock (Hoescht Celanese GUR 415 bar stock obtained from Westlake Plastics, Lenni, PA) was placed in a chamber. The atmosphere within the chamber consisted of low oxygen nitrogen gas (<0.5 ppm oxygen gas) (obtained from AIRCO, Murray Hill, NJ). The pressure in the chamber was approximately 1 atm. The temperature of the sample and the irradiation chamber was controlled using a heater, a variac and a thermocouple readout (manual) or temperature controller (automatic). The chamber was

-23-

heated with a 270 W heating mantle. The chamber was heated (controlled by the variac) at a rate such that the steady state temperature of the sample was about 175°C. The sample was held at the steady state temperature for 30 minutes before starting  
5 the irradiation.

Irradiation was done using a van de Graaff generator with electrons of energy 2.5 MeV and a dose rate of 1.67 MRad/min. The sample was given a dose of 20 MRad with the electron beam hitting the sample on the 60 mm x 12 mm surface. The heater was  
10 switched off after irradiation, and the sample was allowed to cool within the chamber under inert atmosphere, nitrogen gas, to 25°C at approximately 0.5°C/minute. As a control, similar specimens were prepared using unheated and unirradiated bar stock of conventional UHMWPE.

15

Example 2: Comparison of Properties of GUR 415 UHMWPE Bar Stock and Melt-Irradiated (MIR) GUR 415 UHMWPE Bar Stock (20 MRad)

20

This example illustrates various properties of the irradiated and unirradiated samples of UHMWPE bar stock (GUR 415) obtained from Example 1. The tested samples were as follows: the test sample was bar stock which was molten and then irradiated while molten; control was bar stock (no  
25 heating/melting, no irradiation).

(A) Differential Scanning Calorimetry (DSC)

A Perkin-Elmer DSC7 was used with an ice-water heat sink and a heating and cooling rate of 10°C/minute with a continuous nitrogen purge. The crystallinity of the samples obtained from  
30 Example 1 was calculated from the weight of the sample and the heat of melting of polyethylene crystals (69.2 cal/g). The temperature corresponding to the peak of the endotherm was taken as the melting point. The lamellar thickness was calculated by assuming a lamellar crystalline morphology, and knowing  $\Delta H^\circ$  the  
35 heat of melting of 100% crystalline polyethylene (69.2 cal/g), the melting point of a perfect crystal (418.15 K), the density of the crystalline regions (1.005 g/cm<sup>3</sup>) and the end free surface energy of polyethylene (2.22 x 10<sup>-6</sup> cal/cm<sup>2</sup>). The results are shown in Table 1 and FIG. 4.

40

-24-

Table 1: DSC (10°C/min)

<u>Property</u>	GUR 415 (unirradiated) <u>0 MRad</u>	GUR 415 (melt-irradiated) <u>20 MRad</u>
Crystallinity (%)	50.2	37.8
Melting Point (C)	135.8	125.5
Lamellar thickness (Å)	290	137

10

The results indicate that the melt-irradiated sample had a more entangled and less crystalline polymeric structure than the unirradiated sample, as evidenced by lower crystallinity, lower lamellar thickness and lower melting point.

15

(B) Swell Ratio

The samples were cut into cubes of size 2 mm x 2 mm x 2 mm and kept submerged in Decalin at 150°C for a period of 24 hours. An antioxidant (1% N-phenyl-2-naphthylamine) was added to the Decalin to prevent degradation of the sample. The swell ratio and percent extract were calculated by measuring the weight of the sample before the experiment, after swelling for 24 hours and after vacuum drying the swollen sample. The results are shown in Table 2.

25

Table 2: Swelling in Decalin with Antioxidant for 24 hours at 150°C

<u>Property</u>	GUR 415 (unirradiated) <u>0 MRad</u>	GUR 415 (melt-irradiated) <u>20 MRad</u>
Swell Ratio	dissolves	2.5
Extract (%)	approx. 100%	0.0

35

The results indicate that the melt-irradiated UHMWPE sample was highly crosslinked, and hence did not allow dissolution of polymer chains into the hot solvent even after 24 hours, while the unirradiated sample dissolved completely in the hot solvent in the same period.

40

(C) Tensile Elastic Modulus

ASTM 638 M III of the samples was followed. The displacement rate was 1 mm/minute. The experiment was performed on a MTS machine. The results are shown in Table 3.

45

-25-

Table 3: Elastic Test (ASTM 638 M III, 1 mm/min.)

	<u>Property</u>	GUR 415 (unirradiated) <u>0 MRad</u>	GUR 415 (melt-irradiated) <u>20 MRad</u>
5	Tensile Elastic modulus (MPa)	940.7	200.8
	Yield stress	22.7	14.4
	Strain at break (%)	953.8	547.2
10	Engineering UTS (MPa)	46.4	15.4

The results indicate that the melt-irradiated UHMWPE sample had a significantly lower tensile elastic modulus than the unirradiated control. The lower strain at break of the melt-irradiated UHMWPE sample is yet further evidence for the crosslinking of chains in that sample.

(D) Hardness

The hardness of the samples was measured using a durometer on the shore D scale. The hardness was recorded for instantaneous indentation. The results are shown in Table 4.

Table 4: Hardness (Shore D)

	<u>Property</u>	GUR 415 (unirradiated) <u>0 MRad</u>	GUR 415 (melt-irradiated) <u>20 MRad</u>
25	Hardness (D Scale)	65.5	54.5

The results indicate that the melt-irradiated UHMWPE was softer than the unirradiated control.

(E) Light Transmissivity (transparency)

Transparency of the samples was measured as follows: Light transmission was studied for a light of wave length 517 nm passing through a sample of approximately 1 mm in thickness placed between two glass slides. The samples were prepared by polishing the surfaces against 600 grit paper. Silicone oil was spread on the surfaces of the sample and then the sample was placed in between two slides. The silicone oil was used in order to reduce diffuse light scattering due to the surface roughness of the polymer sample. The reference used for this purpose was two similar glass slides separated by a thin film of silicone oil. The transmissivity was measured using a Perkin

Elmer Lambda 3B uv-vis spectrophotometer. The absorption coefficient and transmissivity of a sample exactly 1 mm thick were calculated using the Lambert-Beer law. The results are shown in Table 5.

5 Table 5: Transmissivity of Light at 517 nm

<u>Property</u>	GUR 415 (unirradiated) <u>0 MRad</u>	GUR 415 (melt-irradiated) <u>20 MRad</u>
10 Transmission (%) (1 mm sample)	8.59	39.9
15 Absorption coefficient (cm <sup>-1</sup> )	24.54	9.18

The results indicate that the melt-irradiated UHMWPE sample transmitted much more light through it than the control, and hence is much more transparent than the control.

(F) Environmental Scanning Electron Microscopy (ESEM)

ESEM (ElectroScan, Model 3) was performed on the samples at 10 kV (low voltage to reduce radiation damage to the sample) with an extremely thin gold coating (approximately 20Å to enhance picture quality). By studying the surface of the polymer under the ESEM with and without the gold coating, it was verified that the thin gold coating did not produce any artifacts.

30 The samples were etched using a permanganate etch with a 1:1 sulfuric acid to orthophosphoric acid ratio and a 0.7% (w/v) concentration of potassium permanganate before being viewed under the ESEM.

FIG. 5 shows an ESEM (magnification of 10,000 x) of an etched surface of conventional UHMWPE (GUR 415; unheated; unirradiated). FIG. 6 shows an ESEM (magnification of 10,500 x) of an etched surface of melt-irradiated UHMWPE (GUR 415; melted; 20 MRad). The ESEMs indicated a reduction in size of the crystallites and the occurrence of imperfect crystallization in the melt-irradiated UHMWPE as compared to the conventional UHMWPE.

(G) Fourier Transform Infra Red Spectroscopy (FTIR)

FTIR of the samples was performed using a microsampler on the samples rinsed with hexane to remove surface impurities.

-27-

The peaks observed around 1740 to 1700  $\text{cm}^{-1}$  are bands associated with oxygen containing groups. Hence, the ratio of the area under the carbonyl peak at 1740  $\text{cm}^{-1}$  to the area under the methylene peak at 1460  $\text{cm}^{-1}$  is a measure of the degree of oxidation.

The FTIR spectra indicate that the melt-irradiated UHMWPE sample showed more oxidation than the conventional unirradiated UHMWPE control, but a lot less oxidation than an UHMWPE sample irradiated in air at room temperature and given the same irradiation dose as the melt-irradiated sample.

(H) Electron Paramagnetic Resonance (EPR)

EPR was performed at room temperature on the samples which were placed in a nitrogen atmosphere in an air tight quartz tube. The instrument used was the Bruker ESP 300 EPR spectrometer and the tubes used were Taperlok EPR sample tubes obtained from Wilmad Glass Company, Buena, NJ.

The unirradiated samples do not have any free radicals in them since irradiation is the process which creates free radicals in the polymer. On irradiation, free radicals are created which can last for several years under the appropriate conditions.

The EPR results indicate that the melt-irradiated sample did not show any free radicals when studied using an EPR immediately after irradiation, whereas the sample which was irradiated at room temperature under nitrogen atmosphere showed trans-vinylene free radicals even after 266 days of storage at room temperature. The absence of free radicals in the melt-irradiated UHMWPE sample means that any further oxidative degradation was not possible.

(I) Wear

The wear resistance of the samples was measured using a bi-axial pin-on-disk wear tester. The wear test involved the rubbing action of UHMWPE pins (diameter = 9 mm; height = 13 mm) against a Co-Cr alloy disk. These tests were carried out to a total of 2 million cycles. The unirradiated pin displayed a wear rate of 8 mg/million-cycles while the irradiated pin had a wear rate of 0.5 mg/million cycles. The results indicate that the melt-irradiated UHMWPE has far superior wear resistance than the unirradiated control.

Example 3: Method of Making Melt-Irradiated (MIR) UHMWPE Conventional Articular Cups

This example illustrates electron irradiation of a melted  
5 UHMWPE conventional articular cup.

A conventional articular cup (high conformity unsterilized  
UHMWPE cup made by Zimmer, Inc., Warsaw, IN) of internal  
diameter 26 mm and made of GUR 415 ram extruded bar stock, was  
irradiated under controlled atmosphere and temperature condi-  
10 tions in an air-tight chamber with a titanium cup holder at the  
base and a thin stainless steel foil (0.001 inches thick) at the  
top. The atmosphere within this chamber consisted of low oxygen  
nitrogen gas (< 0.5 ppm oxygen gas) (obtained from AIRCO, Murray  
Hill, NH). The pressure in the chamber was approximately 1 atm.  
15 The chamber was heated using a 270 W heating mantle at the base  
of the chamber which was controlled using a temperature control-  
ler and a variac. The chamber was heated such that the tempera-  
ture at the top surface of the cup rose at approximately 1.5° to  
2°C/min, finally asymptotically reaching a steady state tempera-  
20 ture of approximately 175°C. Due to the thickness of the sample  
cup and the particular design of the equipment used, the steady  
state temperature of the cup varied between 200°C at the base to  
175°C at the top. The cup was held at these temperatures for a  
period of 30 minutes before starting the irradiation.

25 Irradiation was done using a van de Graaff generator with  
electrons of energy 2.5 MeV and a dose rate of 1.67 MRad/min.  
The beam entered the chamber through the thin foil at top and  
hit the concave surface of the cup. The dose received by the  
cup was such that a maximum dose of 20 MRad was received  
30 approximately 5 mm below the surface of the cup being hit by the  
electrons. After irradiation, the heating was stopped and the  
cup was allowed to cool to room temperature (approximately 25°C)  
while still in the chamber with nitrogen gas. The rate of cool-  
ing was approximately 0.5°C/min. The sample was removed from  
35 the chamber after the chamber and the sample had reached room  
temperature.

The above irradiated cup which increases in volume (due to  
the decrease in density accompanying the reduction of  
crystallinity following melt-irradiation) can be remachined to  
40 the appropriate dimensions.

Example 4: Swell Ratio and Percent Extract at Different Depths for Melt-Irradiated (MIR) UHMWPE Articular Cups

5 This example illustrates the swell ratio and percent extract at different depths of the melt-irradiated articular cup obtained from Example 3. Samples of size 2 mm x 2 mm x 2 mm were cut from the cup at various depths along the axis of the cup. These samples were then kept submerged in Decalin at 150°C  
 10 for a period of 24 hours. An antioxidant (1% N-phenyl-2-naphthylamine) was added to the Decalin to prevent degradation of the sample. The swell ratio and percent extract were calculated by measuring the weight of the sample before the experiment, after swelling for 24 hours, and after vacuum drying  
 15 the swollen sample. The results are shown in Table 6.

Table 6: The Swell Ratio and Percent Extract at Different Depths on the Melt-Irradiated UHMWPE Articular Cup

Depth (mm)	Swell Ratio (Decalin, 150 °C, 1 day)	% Extract
0-2	2.43	0.0
2-4	2.52	0.0
25 4-6	2.51	0.0
6-8	2.64	0.0
8-10	2.49	0.0
10-12	3.68	0.0
> 12	6.19	35.8
30 Unirradiated	Dissolves	Approx. 100%

The results indicate that the UHMWPE in the cup had been crosslinked to a depth of 12 mm due to the melt-irradiation  
 35 process to such an extent that no polymer chains dissolved out in hot Decalin over 24 hours.

Example 5: Crystallinity and Melting Point at Different Depths for the Melt-Irradiated (MIR) UHMWPE Articular Cups

40 This example illustrates the crystallinity and melting point at different depths of the melt-irradiated cup obtained from Example 3.

45 Samples were taken from the cup at various depths along the axis of the cup. The crystallinity is the fraction of the polymer that is crystalline. The crystallinity was calculated

by knowing the weight of the sample ( $w$ , in g), the heat absorbed by the sample in melting ( $E$ , in cal which was measured experimentally using a Differential Scanning Calorimeter at  $10^{\circ}\text{C}/\text{min}$ ) and the heat of melting of polyethylene in the 100% crystalline state ( $\Delta H^{\circ} = 69.2 \text{ cal/g}$ ), using the following equation:

$$\% \text{ crystallinity} = \frac{E}{w \cdot \Delta H^{\circ}}$$

The melting point is the temperature corresponding to the peak in the DSC endotherm. The results are shown in FIG. 7.

The results indicate that the crystallinity and the melting point of the melt-irradiated UHMWPE in the articular cups obtained from Example 3 were much lower than the corresponding values of the conventional UHMWPE, even to a depth of 1 cm (the thickness of the cup being 1.2 cms).

Example 6: Second Method of Making Melt-Irradiated (MIR) UHMWPE Articular Cups

This example illustrates a method for making articular cups with melt-irradiated UHMWPE.

Conventional ram extruded UHMWPE bar stock (GUR 415 bar stock obtained from West Lake Plastics, Lenni, PA) was machined to the shape of a cylinder, of height 4 cm and diameter 5.2 cm. One circular face of the cylinder was machined to include an exact hemispherical hole, of diameter 2.6 cm, such that the axis of the hole and the cylinder coincided. This specimen was enclosed in an air-tight chamber with a thin stainless steel foil (0.001 inches thick) at the top. The cylindrical specimen was placed such that the hemispherical hole faced the foil. The chamber was then flushed and filled with an atmosphere of low oxygen nitrogen gas (<0.5 ppm oxygen gas) obtained from AIRCO, Murray Hill, NJ). Following this flushing and filling, a slow continuous flow of nitrogen was maintained while keeping the pressure in the chamber at approximately 1 atm. The chamber was heated using a 270 W heating mantle at the base of the chamber which was controlled using a temperature controller and a variac. The chamber was heated such that the temperature at the top surface of the cylindrical specimen rose at approximately  $1.5^{\circ}\text{C}$  to  $2^{\circ}\text{C}/\text{min}$ , finally asymptotically reaching a steady state

-31-

temperature of approximately 175°C. The specimen was then held at this temperature for a period of 30 minutes before starting irradiation.

Irradiation was done using a van de Graaff generator with 5 electrons of energy 2.5 MeV and a dose rate of 1.67 MRad/min. The beam entered the chamber through the thin foil at top and hit the surface with the hemispherical hole. The dose received by the specimen was such that a maximum dose of 20 MRad was received approximately 5 mm below the surface of the polymer 10 being hit by the electrons. After irradiation, the heating was stopped and the specimen was allowed to cool to room temperature (approximately 25°C) while still in the chamber with nitrogen gas. The rate of cooling was approximately 0.5°C/min. The sample was removed from the chamber after the chamber and the 15 sample had reached room temperature.

This cylindrical specimen was then machined into an articular cup with the dimensions of a high conformity UHMWPE articular cup of internal diameter 26 mm manufactured by Zimmer, Inc., Warsaw, IN, such that the concave surface of the 20 hemispherical hole was remachined into the articulating surface. This method allows for the possibility of relatively large changes in dimensions during melt irradiation.

Example 7: Electron Irradiation of UHMWPE Pucks

25 This example illustrates that electron irradiation of UHMWPE pucks gives a non-uniform absorbed dose profile.

Conventional UHMWPE ram extruded bar stock (Hoescht Celanese GUR 415 bar stock obtained from Westlake Plastics, Lenni, PA) was used. The GUR 415 resin used for the bar stock 30 had a molecular weight of 5,000,000 g/mol and contained 500 ppm of calcium stearate. The bar stock was cut into "hockey puck" shaped cylinders (height 4 cm, diameter 8.5 cm).

The pucks were irradiated at room temperature with an electron-beam incident to one of the circular bases of the pucks 35 with a linear electron accelerator operated at 10 MeV and 1 kW (AECL, Pinawa, Manitoba, Canada), with a scan width of 30 cm and a conveyor speed of 0.08 cm/sec. Due to a cascade effect, electron beam irradiation results in a non-uniform absorbed dose profile. Table 7 illustrates the calculated absorbed dose

values at various depths in a specimen of polyethylene irradiated with 10 MeV electrons. The absorbed doses were the values measured at the top surface (surface of e-beam incidence).

5 Table 7: The variation of absorbed dose as a function of depth in polyethylene

	<u>Depth (mm)</u>	<u>Absorbed Dose (Mrad)</u>
	0	20
10	0.5	22
	1.0	23
	1.5	24
	2.0	25
	2.5	27
15	3.0	26
	3.5	23
	4.0	20
	4.5	8
	5.0	3
20	5.5	1
	6.0	0

---

25 Example 8: Method of Making UHMWPE Using Cold Irradiation and Subsequent Melting (CIR-SM)

This example illustrates a method of making UHMWPE that has a cross-linked structure and has substantially no detectable free radicals, by cold irradiating and then melting the UHMWPE.

30 Conventional UHMWPE ram extruded bar stock (Hoescht Celanese GUR 415 bar stock obtained from Westlake Plastics, Lenni, PA) was used. The GUR 415 resin used for the bar stock had a molecular weight of 5,000,000 g/mol and contained 500 ppm of calcium stearate. The bar stock was cut into "hockey puck" shaped cylinders (height 4 cm, diameter 8.5 cm).

40 The pucks were irradiated at room temperature at a dose rate of 2.5 Mrad per pass to 2.5, 5, 7.5, 10, 12.5, 15, 17.5, 20, 30, and 50 Mrad total absorbed dose as measured on the top surface (electron-beam incidence) (AECL, Pinawa, Manitoba, Canada). The pucks were not packaged and the irradiation was carried out in air. Subsequent to irradiation, the pucks were heated to 150°C under vacuum for 2 hours so as to melt the polymer and thereby result in the recombination of free radicals leading to substantially no detectable residual free radicals. 45 The pucks were then cooled to room temperature at a rate of 5°C/min.

The residual free radicals are measured by electron paramagnetic resonance as described in Jahan et al., J. Biomedical Materials Research 25:1005 (1991).

5 Example 9:            Method of Making UHMWPE Using Warm Irradiation and Subsequent Melting (WIR-SM)

This example illustrates a method of making UHMWPE that has a cross-linked structure and has substantially no detectable  
10 free radicals, by irradiating UHMWPE that has been heated to below the melting point, and then melting the UHMWPE.

Conventional UHMWPE ram extruded bar stock (Hoescht Celanese GUR 415 bar stock obtained from Westlake Plastics, Lenni, PA) was used. The GUR 415 resin used for the bar stock  
15 had a molecular weight of 5,000,000 g/mol and contained 500 ppm of calcium stearate. The bar stock was cut into "hockey puck" shaped cylinders (height 4 cm, diameter 8.5 cm).

The pucks were heated to 100°C in air in an oven. The heated pucks were then irradiated with an electron beam to a  
20 total dose of 20 Mrad at a dose rate of 2.5 Mrad per pass (E-Beam Services, Cranbury, NJ), with a scan width of 30 cm and a conveyor speed of 0.08 cm/sec. Subsequent to irradiation, the pucks were heated to 150°C under vacuum for 2 hours, thereby allowing the free radicals to recombine leading to substantially  
25 no detectable residual free radicals. The pucks were then cooled to room temperature at a rate of 5°C/min.

30 Example 10:            Method of Making UHMWPE Using Warm Irradiation and Adiabatic Melting (WIR-AM)

This example illustrates a method of making UHMWPE that has a cross-linked structure and has substantially no detectable  
35 free radicals, by irradiating UHMWPE that has been heated to below the melting point so as to generate adiabatic melting of the UHMWPE.

Conventional UHMWPE ram extruded bar stock (Hoescht Celanese GUR 415 bar stock obtained from Westlake Plastics, Lenni, PA) was used. The GUR 415 resin used for the bar stock  
40 had a molecular weight of 5,000,000 g/mol and contained 500 ppm of calcium stearate. The bar stock was cut into "hockey puck" shaped cylinders (height 4 cm, diameter 8.5 cm).

-34-

Two pucks were packed in a fiberglass pouch (obtained from Fisher Scientific Co., Pittsburgh, PA) to minimize heat loss in subsequent processing steps. First, the wrapped pucks were heated overnight in an air convection oven kept at 120°C. As soon as the pucks were removed from the oven they were placed under an electron-beam incident to one of the circular bases of the pucks from a linear electron accelerator operated at 10 MeV and 1kW (AECL, Pinawa, Manitoba, Canada), and immediately irradiated to a total dose of 21 and 22.5 Mrad, respectively. The dose rate was 2.7 Mrad/min. Therefore, for 21 Mrad, radiation was for 7.8 min., and for 22.5 Mrad, radiation was for 8.3 min. Following the irradiation, the pucks were cooled to room temperature at a rate of 5°C/minute, at which point the fiberglass pouch was removed and the specimens analyzed.

Example 11: Comparison of Properties of GUR 415 UHMWPE Bar Stock Pucks and CIR-SM and WIR-AM-Treated Bar Stock Pucks

This example illustrates various properties of the irradiated and unirradiated samples of UHMWPE bar stock GUR 415 obtained from Examples 8 and 10. The tested samples were as follows: (i) test samples (pucks) from bar stock which was irradiated at room temperature, subsequently heated to about 150°C for complete melting of polyethylene crystals, followed by cooling to room temperature (CIR-SM), (ii) test samples (pucks) from bar stock which was heated to 120°C in a fiberglass pouch so as to minimize heat loss from the pucks, followed by immediate irradiation to generate adiabatic melting of the polyethylene crystals (WIR-AM), and (iii) control bar stock (no heating/melting, no irradiation).

A. Fourier Transform Infra-Red Spectroscopy (FTIR)

Infra-red (IR) spectroscopy of the samples was performed using a BioRad UMA 500 infrared microscope on thin sections of the samples obtained from Examples 8 and 10. The thin sections (50  $\mu\text{m}$ ) were prepared with a sledge microtome. The IR spectra were collected at 20  $\mu\text{m}$ , 100  $\mu\text{m}$ , and 3 mm below the irradiated surface of the pucks with an aperture size of 10 x 50  $\mu\text{m}^2$ . The peaks observed around 1740 to 1700  $\text{cm}^{-1}$  are associated with the

oxygen containing groups. Hence, the ratio of the area under the carbonyl peak at  $1740\text{ cm}^{-1}$  to the area under the methylene peak at  $1460\text{ cm}^{-1}$ , after subtracting the corresponding baselines, was a measure of the degree of oxidation. Tables 8 and 9 summarize the degree of oxidation for the specimens described in Examples 8 and 10.

These data show that following the cross-linking procedures there was some oxidation within a thin layer of about  $100\mu\text{m}$  thickness. Upon machining this layer away, the final product would have the same oxidation levels as the unirradiated control.

Table 8: Degree of oxidation of specimens from Example 8 (CIR-SM)(with post-irradiation melting in vacuum)

<u>Specimen</u>	<u>Oxidation Degree at various depths (A.U.)</u>		
	<u>20 <math>\mu\text{m}</math></u>	<u>100 <math>\mu\text{m}</math></u>	<u>3 mm</u>
Unirradiated Control	0.01	0.01	0.02
Irradiated to 2.5 Mrad	0.04	0.03	0.03
Irradiated to 5 Mrad	0.04	0.03	0.01
Irradiated to 7.5 Mrad	0.05	0.02	0.02
Irradiated to 10 Mrad	0.02	0.03	0.01
Irradiated to 12.5 Mrad	0.04	0.03	0.01
Irradiated to 15 Mrad	0.03	0.01	0.02
Irradiated to 17.5 Mrad	0.07	0.05	0.02
Irradiated to 20 Mrad	0.03	0.02	0.01

Table 9: Degree of oxidation of specimens from Example 10 (WIR-AM)

<u>Specimen</u>	<u>Oxidation Degree at (A.U.)</u>		
	<u>20 <math>\mu\text{m}</math></u>	<u>100 <math>\mu\text{m}</math></u>	<u>3 mm</u>
Unirradiated Control	0.01	0.01	0.02
Irradiated to 21 Mrad	0.02	0.01	0.03
Irradiated to 22.5 Mrad	0.02	0.02	0.01

#### B. Differential Scanning Calorimetry (DSC)

A Perkin-Elmer DSC7 was used with an ice-water heat sink and a heating and cooling rate of  $10^{\circ}\text{C}/\text{minute}$  with a continuous nitrogen purge. The crystallinity of the specimens obtained from Examples 8 and 10 was calculated from the weight of the sample and the heat of melting of polyethylene crystals measured during the first heating cycle. The percent crystallinity is

given by the following equation:

$$\% \text{ crystallinity} = \frac{E}{w \cdot \Delta H^\circ}$$

5 where E and w are the heat of melting (J or cal) and weight (grams) of the specimen tested, respectively, and  $\Delta H^\circ$  is the heat of melting of 100% crystalline polyethylene in Joules/gram (291 J/g or 69.2 cal/g). The temperature corresponding to the peak  
10 of the endotherm was taken as the melting point. In some cases where there were multiple endotherm peaks, multiple melting points corresponding to these endotherm peaks have been reported. The crystallinities and melting points for the specimens described in Examples 8 and 10 are reported in Tables  
15 10 and 11.

Table 10: DSC at a heating rate of 10°C/min for specimens of Example 8 (CIR-SM)

<u>Specimen</u>	<u>Crystallinity(%)</u>	<u>Melting Point(°C)</u>
Unirradiated Control	59	137
Irradiated to 2.5 Mrad	54	137
Irradiated to 5 Mrad	53	137
25 Irradiated to 10 Mrad	54	137
Irradiated to 20 Mrad	51	137
Irradiated to 30 Mrad	37	137

Table 11: DSC at a heating rate of 10°C/min for specimens of Example 10 (WIR-AM)

<u>Specimen</u>	<u>Crystallinity(%)</u>	<u>Melting Point(°C)</u>
Unirradiated Control	59	137
Irradiated to 21 Mrad	54	120-135-145
Irradiated to 22.5 Mrad	48	120-135-145

40 The data shows that the crystallinity does not change significantly up to absorbed doses of 20 Mrad. Therefore, the elastic properties of the cross-linked material should remain  
45 substantially unchanged upon cross-linking. On the other hand, one could tailor the elastic properties by changing the crystallinity with higher doses. The data also shows that the WIR-AM material exhibited three melting peaks.

### C. Pin-on-Disc Experiments for Wear Rate

The pin-on-disc (POD) experiments were carried out on a bi-axial pin-on-disc tester at a frequency of 2 Hz where polymeric pins were tested by a rubbing action of the pin against a highly polished Co-Cr disc. Prior to preparing cylindrical shaped pins (height 13 mm, diameter 9 mm), one millimeter from the surface of the pucks was machined away in order to remove the outer layer that had been oxidized during irradiation and post- and pre-processing. The pins were then machined from the core of the pucks and tested on the POD such that the surface of e-beam incidence was facing the Co-Cr disc. The wear tests were carried out to a total of 2,000,000 cycles in bovine serum. The pins were weighed at every 500,000 cycle and the average values of weight loss (wear rate) are reported in Tables 12 and 13 for specimens obtained from Examples 8 and 10 respectively.

Table 12: POD wear rates for specimens of Example 8 (CIR-SM)

<u>Specimen</u>	<u>Wear Rate (mg/million cycle)</u>
Unirradiated Control	9.78
Irradiated to 2.5 Mrad	9.07
Irradiated to 5 Mrad	4.80
Irradiated to 7.5 Mrad	2.53
Irradiated to 10 Mrad	1.54
Irradiated to 15 Mrad	0.51
Irradiated to 20 Mrad	0.05
Irradiated to 30 Mrad	0.11

Table 13: POD wear rates for specimens of Example 10 (WIR-AM)

<u>Specimen</u>	<u>Wear Rate (mg/million cycle)</u>
Unirradiated Control	9.78
Irradiated to 21 Mrad	1.15

The results indicate that the cross-linked UHMWPE has far superior wear resistance than the unirradiated control.

### D. Gel Content and Swell Ratio

The samples were cut in cubes of size 2 x 2 x 2 mm<sup>3</sup> and kept submerged in xylene at 130°C for a period of 24 hours. An antioxidant (1% N-phenyl-2-naphthylamine) was added to the xylene to prevent degradation of the sample. The swell ratio

-38-

and gel content were calculated by measuring the weight of the sample before the experiment, after swelling for 24 hours and after vacuum drying the swollen sample. The results are shown in Tables 14 and 15 for the specimens obtained from Examples 8 and 10.

Table 14: Gel content and swell ratio for specimens of Example 8 (CIR-SM)

<u>Specimen</u>	<u>Gel Content(%)</u>	<u>Swell Ratio</u>
Unirradiated Control	89.7	12.25
Irradiated to 5 Mrad	99.2	4.64
Irradiated to 10 Mrad	99.9	2.48
Irradiated to 20 Mrad	99.0	2.12
Irradiated to 30 Mrad	99.9	2.06

Table 15: Gel content and swell ratio for specimens of Example 10 (WIR-AM)

<u>Specimen</u>	<u>Gel Content(%)</u>	<u>Swell Ratio</u>
Unirradiated Control	89.7	12.25
Irradiated to 21 Mrad	99.9	2.84
Irradiated to 22.5 Mrad	100	2.36

The results show that the swell ratio decreased with increasing absorbed dose indicating an increase in the cross-link density. The gel content increased indicating the formation of a cross-linked structure.

Example 12: Free Radical Concentration for UHMWPE Prepared by Cold Irradiation With and Without Subsequent Melting (CIR-SM)

This example illustrates the effect of melting subsequent to cold irradiation of UHMWPE on the free radical concentration. Electron paramagnetic resonance (EPR) was performed at room temperature on the samples after placing in a nitrogen atmosphere in an air tight quartz tube. The instrument used was the Bruker ESP 300 EPR spectrometer and the tubes used were Taperlok EPR sample tubes (obtained from Wilmad Glass Co., Buena, NJ).

The unirradiated samples did not have any detectable free radicals in them. During the process of irradiation, free radicals are created which can last for at least several years under the appropriate conditions.

The cold-irradiated UHMWPE specimens exhibited a strong

-39-

free radical signal when tested with the EPR technique. When the same samples were examined with EPR following a melting cycle, the EPR signal was found to be reduced to undetectable levels. The absence of free radicals in the cold irradiated subsequently melted (recrystallized) UHMWPE sample means that any further oxidative degradation cannot occur via attack on entrapped radicals.

Example 13: Crystallinity and Melting Point at Different Depths for UHMWPE Prepared by Cold Irradiation and Subsequent Melting (CIR-SM)

This example illustrates the crystallinity and melting point at different depths of the cross-linked UHMWPE specimens obtained from Example 8 with 20 Mrad total radiation dose. Samples were taken at various depths from the cross-linked specimen. The crystallinity and the melting point were determined using a Perkin Elmer differential scanning calorimeter as described in Example 10(B). The results are shown in Table 16.

Table 16: DSC at a heating rate of 10°C/min for specimen of Example 8 irradiated to a total dose of 20 Mrad (CIR-SM)

<u>Depth (mm)</u>	<u>Crystallinity(%)</u>	<u>Melting Point(°C)</u>
0-2	53	137
6-8	54	137
9-11	54	137
14-16	34	137
20-22	52	137
26-28	56	137
29-31	52	137
37-40	54	137
Unirradiated Control	59	137

The results indicate that the crystallinity varied as a function of depth away from the surface. The sudden drop in 16 mm is the consequence of the cascade effect. The peak in the absorbed dose was located around 16 mm where the dose level could be as high as 27 Mrad.

Example 14: Comparison of UHMWPE Prepared by CIR-SM Using Melting in Air Versus Melting Under Vacuum

This example illustrates that the oxidation levels of

-40-

UHMWPE pucks prepared by CIR-SM, whether melted in air or under vacuum, are the same as unirradiated pucks at a depth of 3mm below the surface of the pucks.

Conventional UHMWPE ram extruded bar stock (Hoescht  
5 Celanese GUR 415 bar stock obtained from Westlake Plastics,  
Lenni, PA) was used. The GUR 415 resin used for the bar stock  
had a molecular weight of 5,000,000 g/mol and contained 500 ppm  
of calcium stearate. The bar stock was cut into "hockey puck"  
shaped cylinders (height 4 cm, diameter 8.5 cm).

10 Two pucks were irradiated at room temperature with a dose  
rate of 2.5 Mrad per pass to 17.5 Mrad total absorbed dose as  
measured on the top surface (e-beam incidence) (AECL, Pinawa,  
Manitoba, Canada), with a scan width of 30 cm and a conveyor  
speed of 0.07 cm/sec. The pucks were not packaged and the  
15 irradiation was carried out in air. Subsequent to irradiation,  
one puck was heated under vacuum to 150°C for 2 hours, and the  
other puck was heated in air to 150°C for 2 hours, so as to  
attain a state of no detectable residual crystalline content and  
no detectable residual free radicals. The pucks were then  
20 cooled to room temperature at a rate of 5°C/min. The pucks were  
then analyzed for the degree of oxidation as described in  
Example 11(A). Table 17 summarizes the results obtained for the  
degree of oxidation.

25 Table 17: Degree of oxidation of specimens melted in air  
versus in vacuum

<u>(A.U.)</u>	<u>Specimen</u>	<u>Post-Melting Environment</u>	<u>Oxidation Degree at various depths</u>		
			<u>20 <math>\mu</math>m</u>	<u>100 <math>\mu</math>m</u>	<u>3 mm</u>
	Unirradiated Control	N/A	0.01	0.01	0.02
	Irradiated to 17.5 Mrad	Vacuum	0.07	0.05	0.02
	Irradiated to 17.5 Mrad	Air	0.15	0.10	0.01

35 The results indicated that within 3 mm below the free  
surfaces the oxidation level in the irradiated UHMWPE specimens  
dropped to oxidation levels observed in unirradiated control  
UHMWPE. This was the case independent of post-irradiation  
40 melting atmosphere (air or vacuum). Therefore, post-irradiation  
melting could be done in an air convection oven without  
oxidizing the core of the irradiated puck.

Example 15:        Method of Making UHMWPE Using Cold Irradiation and Subsequent Melting Using Gamma Irradiation (CIR-SM)

5            This example, illustrates a method of making UHMWPE that has a cross-linked structure and has substantially no detectable free radicals, by cold irradiating with gamma-radiation and then melting the UHMWPE.

10           Conventional UHMWPE ram extruded bar stock (Hoescht Celanese GUR 415 bar stock obtained from Westlake Plastics, Lenni, PA) was used. The GUR 415 resin used for the bar stock had a molecular weight of 5,000,000 g/mol and contained 500 ppm of calcium stearate. The bar stock was cut into "hockey puck" shaped cylinders (height 4 cm, diameter 8.5 cm).

15           The pucks were irradiated at room temperature at a dose rate of 0.05 Mrad/minute to 4 Mrad total absorbed dose as measured on the top surface (gamma ray incidence) (Isomedix, Northboro, MA). The pucks were not packaged and irradiation was carried out in air. Subsequent to irradiation, the pucks were  
20           heated to 150°C under vacuum for 2 hours so as to melt the polymer and thereby result in the recombination of free radicals leading to substantially no detectable residual free radicals.

25           Example 16:        I. Method of Making UHMWPE Using Warm Irradiation and Partial Adiabatic Melting with Subsequent Complete Melting (WIR-AM)

30           This example illustrates a method of making UHMWPE that has a cross-linked structure, exhibits two distinct melting endotherms in a differential scanning calorimeter (DSC), and has substantially no detectable free radicals, by irradiating UHMWPE that has been heated to below the melting point so as to generate adiabatic partial melting of the UHMWPE and by subsequently melting the UHMWPE.

35           A GUR 4050 bar stock (made from ram extruded Hoescht Celanese GUR 4050 resin obtained from Westlake Plastics, Lenni, PA) was machined into 8.5 cm diameter and 4 cm thick hockey pucks. Twenty-five pucks, 25 aluminum holders and 25 20cm x 20cm fiberglass blankets were preheated to 125°C overnight in an  
40           air convection oven. The preheated pucks were each placed in a preheated aluminum holder which was covered by a preheated fiberglass blanket to minimize heat loss to the surroundings

-42-

during irradiation. The pucks were then irradiated in air using a 10 MeV, 1 kW electron beam with a scan width of 30 cm (AECL, Pinawa, Manitoba, Canada). The conveyor speed was 0.07 cm/sec which gave a dose rate of 70 kGy per pass. The pucks were irradiated in two passes under the beam to achieve a total absorbed dose of 140 kGy. For the second pass, the conveyor belt motion was reversed as soon as the pucks were out of the electron beam raster area to avoid any heat loss from the pucks. Following the warm irradiation, 15 pucks were heated to 150°C for 2 hours so as to obtain complete melting of the crystals and substantial elimination of the free radicals.

A. Thermal Properties (DSC) of the specimens prepared in Example 16

A Perkin-Elmer DSC 7 was used with an ice water heat sink and a heating and cooling rate of 10°C/min with a continuous nitrogen purge. The crystallinity of the samples obtained from Example 16 was calculated from the weight of the sample and the heat of melting of polyethylene crystals (69.2 cal/gm). The temperature corresponding to the peak of the endotherm was taken as the melting point. In the case of multiple endotherm peaks, multiple melting points were reported.

Table 18 shows the variations obtained in the melting behavior and crystallinity of the polymer as a function of depth away from the e-beam incidence surface. FIG. 8 shows representative DSC melting endotherms obtained at 2 cm below the surface of e-beam incidence obtained both before and after the subsequent melting.

30

**Table 18: WIR-AM GUR 4050 barstock, Total dose=140 kGy, 75 kGy/pass**

Depth (mm)	T 1st peak after irradiation (°C)	T 2nd peak after irradiation (°C)	T 3rd peak after irradiation (°C)	T 1st peak after subsequent melting (°C)	T 2nd peak after subsequent melting (°C)	Crystallinity after irradiation (%)	Crystallinity after subsequent melting (%)
1.77	109.70	NP	145.10	116.35	139.45	53.11	45.26
5.61	118.00	NP	147.80	117.10	141.60	52.61	45.46
9.31	113.00	NP	146.40	117.30	141.10	50.13	44.42
13.11	113.47	138.07	145.23	116.03	139.83	47.29	43.33
16.89	113.40	137.40	144.80	115.90	139.30	47.68	43.05
20.95	113.70	138.33	145.17	115.17	139.63	44.99	43.41
24.60	112.40	134.20	143.90	114.90	138.70	49.05	44.40
28.57	112.30	NP	145.70	115.90	139.90	50.84	44.40
31.89	111.20	NP	144.50	114.90	138.80	51.88	45.28
34.95	NP	NP	143.90	112.00	138.45	50.09	45.36
39.02	NP	NP	139.65	114.95	138.30	49.13	46.03

\*NP: The peak is not present

-44-

These results indicate that the melting behavior of UHMWPE changes drastically after the subsequent melting step in this embodiment of the WIR-AM process. Before the subsequent melting, the polymer exhibited three melting peaks, while after subsequent melting it exhibited two melting peaks.

B. Electron Paramagnetic Resonance (EPR) of the specimens prepared in Example 16

EPR was performed at room temperature on samples obtained from Example 16 after placing the samples in an air tight quartz tube in a nitrogen atmosphere. The instrument used was the Bruker ESP 300 EPR spectrometer and the tubes used were Taperlok EPR sample tubes (obtained from Wilmad Glass Co., Buena, NJ).

The unirradiated samples did not have any detectable free radicals in them. During the process of irradiation, free radicals are created which can last for at least several years under the appropriate conditions.

Before the subsequent melting, the EPR results showed a complex free radical peak composed of both peroxy and primary free radicals. After the subsequent melting the EPR free radical signal was reduced to undetectable levels. These results indicated that the free radicals induced by the irradiation process were substantially eliminated after the subsequent melting step. Thus, the UHMWPE was highly resistant to oxidation.

Example 17: II. Method of Making UHMWPE Using Warm Irradiation and Partial Adiabatic Melting with Subsequent Complete Melting (WIR-AM)

This example illustrates a method of making UHMWPE that has a cross-linked structure, exhibits two distinct melting endotherms in DSC, and has substantially no detectable free radicals, by irradiating UHMWPE that has been heated to below the melting point so as to generate the adiabatic partial melting of the UHMWPE and by subsequently melting the UHMWPE.

A GUR 4020 bar stock (made from ram extruded Hoescht Celanese GUR 4020 resin obtained from Westlake Plastics, Lenni, PA) was machined into 8.5 cm diameter and 4 cm thick hockey pucks. Twenty-five pucks, 25 aluminum holders and 25 20cm x 20cm fiberglass blankets were preheated to 125°C overnight in an

-45-

air convection oven. The preheated pucks were each placed in a preheated aluminum holder which was covered by a preheated fiberglass blanket to minimize heat loss to the surroundings during irradiation. The pucks were then irradiated in air using a 10 MeV, 1 kW electron beam with a scan width of 30 cm (AECL, Pinawa, Manitoba, Canada). The conveyor speed was 0.07 cm/sec which gave a dose rate of 70 kGy per pass. The pucks were irradiated in two passes under the beam to achieve a total absorbed dose of 140 kGy. For the second pass, the conveyor belt motion was reversed as soon as the pucks were out of the electron beam raster area to avoid any heat loss from the pucks. Following the warm irradiation, 15 pucks were heated to 150°C for 2 hours so as to obtain complete melting of the crystals and substantial elimination of the free radicals.

Example 18: III. Method of Making UHMWPE Using Warm Irradiation and Partial Adiabatic Melting with Subsequent Complete Melting (WIR-AM)

This example illustrates a method of making UHMWPE that has a cross-linked structure, exhibits two distinct melting endotherms in DSC, and has substantially no detectable free radicals, by irradiating UHMWPE that has been heated to below the melting point so as to generate adiabatic partial melting of the UHMWPE and by subsequently melting the UHMWPE.

A GUR 1050 bar stock (made from ram-extruded Hoescht Celanese GUR 1050 resin obtained from Westlake Plastics, Lenni, PA) was machined into 8.5 cm diameter and 4 cm thick hockey pucks. Eighteen pucks, 18 aluminum holders and 18 20cm x 20cm fiberglass blankets were preheated to 125°C, 90°C, or 70°C, in an air convection oven overnight. Six pucks were used for each different pre-heat temperature. The preheated pucks were each placed in a preheated aluminum holder which was covered by a preheated fiberglass blanket to minimize heat loss to the surroundings during irradiation. The pucks were then irradiated in air using a 10 MeV and 1 kW electron beam with a scan width of 30 cm (AECL, Pinawa, Manitoba, Canada). The conveyor speed was 0.06 cm/sec which gave a dose rate of 75 kGy per pass. The pucks were irradiated in two passes under the beam to accumulate a total of 150 kGy of absorbed dose. For the second pass, the

-46-

conveyor belt motion was reversed as soon as the pucks were out of the electron beam raster area to avoid any heat loss from the pucks. Following the warm irradiation, half of the pucks were heated to 150°C for 2 hours so as to obtain complete melting of the crystals and substantial elimination of the free radicals.

A. Thermal Properties of the Specimens Prepared in Example 18

10 A Perkin-Elmer DSC 7 was used with an ice water heat sink and a heating and cooling rate of 10°C/min with a continuous nitrogen purge. The crystallinity of the samples obtained from Example 18 was calculated from the weight of the sample and the heat of melting of polyethylene crystals (69.2 cal/gm). The  
15 temperature corresponding to the peak of the endotherm was taken as the melting point. In the case of multiple endotherm peaks, multiple melting points were reported.

Table 19 shows the effect of pre-heat temperature on the melting behavior and crystallinity of the polymer. FIG. 9 shows  
20 the DSC profile of a puck processed with the WIR-AM method at a pre-heat temperature of 125°C both before and after subsequent melting.

**Table 19: WIR-AM GUR 1050 barstock, Total dose = 150 kGy, 75 kGy/pass**

Preheat (°C)	T 1st peak after irradiation (°C)	T 2nd peak after irradiation (°C)	T 3rd peak after irradiation (°C)	T 1st peak after subsequent melting (°C)	T 2nd peak after subsequent melting (°C)	Crystallinity after irradiation (%)	Crystallinity after subsequent melting (%)
125	114.6	135.70	143.5	114.85	135.60	42.81	40.85
90	NP	142.85	NP	116.75	136.95	52.39	44.31
70	NP	141.85	NP	NP	136.80	51.59	44.62

\*NP: The peak is not present

These results indicate that the melting behavior of UHMWPE changes drastically after the subsequent melting step in this embodiment of the WIR-AM process. Before the subsequent melting, the polymer exhibited three melting peaks, while after subsequent melting it exhibited two melting peaks.

Example 19:      IV. Method of Making UHMWPE Using Warm Irradiation and Partial Adiabatic Melting with Subsequent Complete Melting (WIR-AM)

This example illustrates a method of making UHMWPE that has a cross-linked structure, exhibits two distinct melting endotherms in DSC, and has substantially no detectable free radicals, by irradiating UHMWPE that has been heated to below the melting point so as to generate adiabatic partial melting of the UHMWPE and by subsequently melting the polymer.

A GUR 1020 bar stock (made from ram extruded Hoescht Celanese GUR 1020 resin obtained from Westlake Plastics, Lenni, PA) was machined in 7.5 cm diameter and 4 cm thick hockey pucks. Ten pucks, 10 aluminum holders and 10 20cm x 20cm fiberglass blankets were preheated to 125°C overnight in an air convection oven. The preheated pucks were each placed in a preheated aluminum holder which was covered by a preheated fiberglass blanket to minimize heat loss to the surroundings during irradiation. The pucks were then irradiated in air using a 10 MeV, 1 kW linear electron beam accelerator (AECL, Pinawa, Manitoba, Canada). The scan width and the conveyor speed was adjusted to achieve the desired dose rate per pass. The pucks were then irradiated to 61, 70, 80, 100, 140, and 160 kGy of total absorbed dose. For 61, 70, 80 kGy absorbed dose, the irradiation was completed in one pass; while for 100, 140, and 160 it was completed in two passes. For each absorbed dose level, six pucks were irradiated. During the two pass experiments, for the second pass, the conveyor belt motion was reversed as soon as the pucks were out of the electron beam raster area to avoid any heat loss from the pucks. Following the irradiation, half of the pucks were heated to 150°C for 2 hours in an air convection oven so as to obtain complete melting of the crystals and substantial elimination of the free radicals.

Example 20: V. Method of Making UHMWPE Using Warm Irradiation and Partial Adiabatic Melting with Subsequent Complete Melting (WIR-AM)

5 This example illustrates a method of making UHMWPE that has a cross-linked structure, exhibits two distinct melting endotherms in DSC, and has substantially no detectable free radicals, by irradiating UHMWPE that has been heated to below the melting point so as to generate adiabatic partial melting of  
10 the UHMWPE and by subsequently melting the polymer.

A GUR 4150 bar stock (made from ram extruded Hoescht Celanese GUR 4150 resin obtained from Westlake Plastics, Lenni, PA) was machined into 7.5 cm diameter and 4 cm thick hockey pucks. Ten pucks, 10 aluminum holders and 10 20cm x 20cm  
15 fiberglass blankets were preheated to 125°C overnight in an air convection oven. The preheated pucks were each placed in a preheated aluminum holder which was covered by a preheated fiberglass blanket to minimize heat loss to the surroundings during irradiation. The pucks were then irradiated in air using  
20 a 10 MeV, 1 kW linear electron beam accelerator (AECL, Pinawa, Manitoba, Canada). The scan width and the conveyor speed was adjusted to achieve the desired dose rate per pass. The pucks were irradiated to 61, 70, 80, 100, 140, and 160 kGy of total absorbed dose. For each absorbed dose level, six pucks were  
25 irradiated. For 61, 70, 80 kGy absorbed dose, the irradiation was completed in one pass; for 100, 140 and 160 kGy, it was completed in two passes.

Following the irradiation, three pucks out of each different absorbed dose level were heated to 150°C for 2 hours  
30 to completely melt the crystals and reduce the concentration of free radicals to undetectable levels.

A. Properties of the Specimens Prepared in Example 20

A Perkin-Elmer DSC 7 was used with an ice water heat sink  
35 and a heating and cooling rate of 10°C per minute with a continuous nitrogen purge. The crystallinity of the samples obtained from Example 20 was calculated from the weight of the sample and the heat of melting of polyethylene crystals (69.2 cal/gm). The temperature corresponding to the peak of the  
40 endotherm was taken as the melting point. In the case of

-50-

multiple endotherm peaks, multiple melting points were reported.

The results obtained are shown in Table 20 as a function of total absorbed dose level. They indicate that crystallinity decreases with increasing dose level. At the absorbed dose  
5 levels studied, the polymer exhibited two melting peaks ( $T_1 =$   
 $\sim 118^\circ\text{C}$ ,  $T_2 = \sim 137^\circ\text{C}$ ) after the subsequent melting step.

Table 20: WIR-AM GUR 4150 barstock

Irradiation dose (kGy)	T 1st peak after irradiation (°C)	T 2nd peak after irradiation (°C)	T 3rd peak after irradiation (°C)	T 1st peak after subsequent melting (°C)	T 2nd peak after subsequent melting (°C)	Crystallinity after irradiation (%)	Crystallinity after subsequent melting (%)
160	113.4	135.10	143.20	114	135.90	41.97	39.58
140	114.6	135.10	143.60	116.2	138.60	45.25	41.51
100	118.7	125.10	143.50	118.2	138.20	47.18	42.58
80	115.7	NP	142.00	119.1	137.60	50.61	44.52
70	114.8	NP	141.40	118.9	137.00	52.36	44.95
61	114.6	NP	140.20	119.1	136.00	53.01	45.04

\*NP: The peak is not present

Example 21: Temperature Rise during WIR-AM Process

This example demonstrates that the temperature rises during the warm irradiation process leading to adiabatic partial or complete melting of the UHMWPE.

5 A GUR 4150 bar stock (made from ram extruded Hoescht  
Celanese GUR 4150 resin obtained from Westlake Plastics, Lenni,  
PA) was machined into a 8.5 cm diameter and 4 cm thick hockey  
puck. One hole was drilled into the body-center of the puck. A  
Type K thermocouple was placed in this hole. The puck was pre-  
10 heated to 130°C in air convection oven. The puck was then  
irradiated using 10 MeV, 1 kW electron beam (AECL, Pinawa,  
Manitoba, Canada). The irradiation was carried out in air with  
a scan width of 30 cm. The dose rate was 27 kGy/min and the  
puck was left stationary under the beam. The temperature of the  
15 puck was constantly measured during irradiation.

FIG. 10 shows the temperature rise in the puck obtained  
during the irradiation process. Initially, the temperature is  
at the pre-heat temperature (130°C). As soon as the beam is  
turned on, the temperature increases, during which time the  
20 UHMWPE crystals melt. There is melting of smaller size crystals  
starting from 130°C, indicating that partial melting occurs  
during the heating. At around 145°C where there is an abrupt  
change in the heating behavior, complete melting is achieved.  
After that point, temperature continues to rise in the molten  
25 material.

This example demonstrates that during the WIR-AM process,  
the absorbed dose level (duration of irradiation) can be  
adjusted to either partially or completely melt the polymer. In  
the former case, the melting can be completed with an additional  
30 melting step in an oven to eliminate the free radicals.

Example 22: Method of Making UHMWPE Using Cold Irradiation  
and Adiabatic Heating with Subsequent Complete  
Melting (CIR-AM)

35 This example illustrates a method of making UHMWPE that has  
a cross-linked structure, and has substantially no detectable  
free radicals, by irradiating UHMWPE at a high enough dose rate  
to generate adiabatic heating of the UHMWPE and by subsequently  
40 melting the polymer.

A GUR 4150 bar stock (made from ram extruded Hoescht Celanese GUR 4150 resin obtained from Westlake Plastics, Lenni, PA) was machined into 8.5 cm diameter and 4 cm thick hockey pucks. Twelve pucks were irradiated stationary, in air, at a dose rate of 60 kGy/min using 10 MeV, 30 kW electrons (E-Beam Services, Cranbury, NJ). Six of the pucks were irradiated to a total dose of 170 kGy, while the other six were irradiated to a total dose of 200 kGy. At the end of the irradiation the temperature of the pucks was greater than 100°C.

Following the irradiation, one puck of each series was heated to 150°C for 2 hours to melt all the crystals and reduce the concentration of free radicals to undetectable levels.

A. Thermal Properties of the Specimens Prepared in Example 22

A Perkin-Elmer DSC 7 was used with an ice water heat sink and a heating and cooling rate of 10°C per minute with a continuous nitrogen purge. The crystallinity of the samples obtained from Example 22 was calculated from the weight of the sample and the heat of melting of polyethylene crystals (69.2 cal/gm). The temperature corresponding to the peak of the endotherm was taken as the melting point.

Table 21 summarizes the effect of total absorbed dose on the thermal properties of CIR-AM UHMWPE both before and after the subsequent melting process. The results obtained indicate one single melting peak both before and after the subsequent melting step.

Table 21: CIR-AM GUR 4150 barstock

Irradiation dose (kGy)	T peak after irradiation (°C)	T peak after subsequent melting (°C)	Crystallinity after irradiation (%)	Crystallinity after subsequent melting (%)
170	143.67	137.07	58.25	45.27
200	143.83	136.73	54.74	43.28

Example 23: Comparison of Tensile Deformation Behavior of Unirradiated UHMWPE, Cold-Irradiated and Subsequently Melted UHMWPE (CIR-SM), and Warm Irradiated and Partially Adiabatic Melted and Subsequently Melted UHMWPE (WIR-AM)

This example compares the tensile deformation behavior of UHMWPE in its unirradiated form, and irradiated forms via CIR-SM and WIR-AM methods.

The ASTM D638 Type V standard was used to prepare dog bone specimens for the tensile test. The tensile test was carried out on an Instron 4120 Universal Tester at a cross-head speed of 10 mm/min. The engineering stress-strain behavior was calculated from the load-displacement data following ASTM D638.

The dog bone specimens were machined from GUR 4150 hockey pucks (made from ram extruded Hoescht Celanese GUR 4150 resin obtained from Westlake Plastics, Lenni, PA) that were treated by CIR-SM and WIR-AM methods. For the CIR-SM, the method described in Example 8 was followed, while for WIR-AM, the method described in Example 17 was followed. In both cases, the total dose administered was 150 kGy.

FIG. 11 shows the tensile behavior obtained for the unirradiated control, CIR-SM treated, and WIR-AM treated specimens. It shows the variation in tensile deformation behavior in CIR-SM and WIR-AM treated UHMWPE, even though in both methods the irradiation was carried out to 150 kGy. This difference is due to the two phase structure generated by using the WIR-AM method.

Those skilled in the art will be able to ascertain using no more than routine experimentation, many equivalents of the specific embodiments of the invention described herein. These and all other equivalents are intended to be encompassed by the following claims.

- 55 -

1. A medical prosthesis for use within the body, said prosthesis being formed of radiation treated ultra high molecular weight polyethylene (UHMWPE) having cross-links and multiple melting peaks, wherein the UHMWPE has a tensile elastic modulus of less than about 940 MPa, and wherein the UHMWPE is substantially oxidation resistant.
2. The prosthesis of claim 1 wherein said UHMWPE has a cross-linked structure, so as to reduce production of particles from said prosthesis during wear of said prosthesis.
3. The prosthesis of claim 1 wherein said UHMWPE is substantially not oxidized.
4. The prosthesis of claim 1 wherein said UHMWPE has three melting peaks.
5. The prosthesis of claim 1 wherein said UHMWPE has two melting peaks.
6. The prosthesis of claim 1 wherein said UHMWPE has been subjected to heating by irradiation.
7. The prosthesis of claim 1 wherein said polymeric structure has extensive cross-linking so that a substantial portion of said polymeric structure does not dissolve in xylene at 130°C or decalin at 150°C over a period of 24 hours.
8. The prosthesis of claim 1 wherein said UHMWPE has an initial average molecular weight of greater than about 1 million.
9. The prosthesis of claim 1 wherein part of said prosthesis is in the form of a cup or tray shaped article having a load bearing surface.

- 56 -

10. The prosthesis of claim 7 wherein a load bearing surface is in contact with a second part of said prosthesis having a mating load bearing surface of a metallic or ceramic material.
11. The prosthesis of claim 1 wherein said prosthesis is constructed and arranged for replacement of a joint selected from the group consisting of a hip joint, a knee joint, an elbow joint, a shoulder joint, an ankle joint and a finger joint.
12. The prosthesis of claim 1 wherein said UHMWPE has a polymeric structure with less than about 50% crystallinity and less than about 940 MPa tensile elastic modulus, so as to reduce production of fine particles from said prosthesis during wear of said prosthesis.
13. The prosthesis of claim 12 wherein said UHMWPE has a hardness of less than about 65 on the Shore D scale.
14. The prosthesis of claim 12 wherein said radiation treated UHMWPE is highly entangled.
15. The prosthesis of claim 12 wherein said UHMWPE has a polymeric structure with between about 40% to about 50% crystallinity.
16. Radiation treated ultra high molecular weight polyethylene (UHMWPE) having multiple melting peaks and cross-links, wherein the multiple melting peaks are a result of irradiation-generated heat, wherein the UHMWPE has a tensile elastic modulus of less than about 940 MPa and wherein the UHMWPE is substantially oxidation resistant.
17. The UHMWPE of claim 16 wherein said UHMWPE has three melting peaks.

- 57 -

18. The UHMWPE of claim 16 wherein said UHMWPE has two melting peaks.
19. The UHMWPE of claim 16 wherein said UHMWPE has been subjected to heating by irradiation.
20. The UHMWPE of claim 16 wherein said UHMWPE has a unique polymeric structure characterized by less than about 50% crystallinity and less than about 940 MPa tensile elastic modulus.
21. The UHMWPE of claim 20 wherein said UHMWPE has high transmissivity of light.
22. The UHMWPE of claim 20 wherein said UHMWPE is a film or sheet, said film or sheet being transparent and wear resistant.
23. A fabricated article formed of the radiation treated UHMWPE of any one of claims 16 to 21.
24. The fabricated article of claim 23 wherein said fabricated article is in the form of a bar stock capable of being shaped into a second article by machining.
25. The fabricated article of claim 23 wherein said fabricated article has a load bearing surface.
26. A method for making a cross-linked ultra high molecular weight polyethylene (UHMWPE) having multiple melting peaks, wherein the multiple melting peaks are a result of irradiation-generated heat, comprising the steps of:
  - a) providing UHMWPE having polymeric chains;
  - b) irradiating said UHMWPE so as to cross-link said polymeric chains; and

- 58 -

c) cooling said heated UHMWPE, wherein the UHMWPE has a tensile elastic modulus of less than about 940 MPa.

27. The method of claim 26 wherein said UHMWPE in said providing step is heated to a temperature above room temperature but below the melting temperature of said UHMWPE.

28. A method for making a cross-linked ultra high molecular weight polyethylene (UHMWPE), comprising the steps of:

a) providing UHMWPE having polymeric chains that is at room temperature or below room temperature;

b) irradiating said UHMWPE so as to cross-link said polymeric chains and to generate sufficient heat to at least partially melt the UHMWPE; and

c) cooling said heated UHMWPE, wherein the UHMWPE has a tensile elastic modulus of less than about 940 MPa.

29. A method for making cross-linked ultra high molecular weight polyethylene (UHMWPE), comprising the steps of:

a) providing UHMWPE at a temperature of no more than about 90°C;

b) irradiating said UHMWPE to cross-link the UHMWPE and to generate sufficient heat to at least partially melt the UHMWPE; and

c) cooling said irradiated UHMWPE, wherein the UHMWPE has a tensile elastic modulus of less than about 940 MPa.

30. A method for making cross-linked ultra high molecular weight polyethylene (UHMWPE), comprising the steps of:

- 59 -

a) providing UHMWPE at a temperature ranging from about 90°C to below the melting point;

b) irradiating said UHMWPE to cross-link the UHMWPE and to generate sufficient heat to at least partially melt the UHMWPE; and

c) cooling said irradiated and heated UHMWPE, wherein the UHMWPE has a tensile elastic modulus of less than about 940 MPa.

31. A method for making a cross-linked ultra high molecular weight polyethylene (UHMWPE) having substantially no detectable free radicals, comprising the steps of:

a) providing UHMWPE having polymeric chains, wherein the UHMWPE is at a temperature below its melting point;

b) irradiating said UHMWPE with more than 5 Mrads of radiation so as to cross-link said polymeric chains; and

c) cooling said heated UHMWPE, wherein the UHMWPE has a tensile elastic modulus of less than about 940 MPa.

32. The method of claim 27 wherein the final temperature of said UHMWPE after said step (b) is above the melting temperature of said ultra high molecular weight polyethylene.

33. The method of any of claims 28 to 31, further comprising the a step of heating said irradiated UHMWPE so that the final temperature of said UHMWPE after said additional heating is above the melting temperature of said UHMWPE.

34. The method of any of claims 26 to 33 wherein step (b) uses electron irradiation.

- 60 -

35. The method of claim 31 wherein step (b) uses gamma irradiation.
36. The method of any of claims 26, 27 and 31 to 33, wherein said irradiation generates heating sufficient to at least partially melt said UHMWPE.
37. The method of any of claims 26 to 33, wherein step (b) uses electron irradiation and the dose rate of at least 4 Mrad/minute.
38. The method of any of claims 26 to 33, wherein step (b) uses electron irradiation and the dose rate of said electron irradiation is about 0.05 to about 3,000 Mrad/minute.
39. The method of any of claims 26 to 33, wherein the dose rate from said irradiating step is about 0.05 to about 5 Mrad/minute.
40. The methods of any of claims 26 to 33, wherein the dose rate from said irradiation is about 0.05 to about 10 Mrad/minute.
41. The methods of any of claims 26 to 33, wherein the dose rate from said irradiation is about 4 to about 5 Mrad/minute.
42. The method of any of claims 26 to 33, wherein the dose rate of said irradiation is about 2 to about 3,000 Mrad/minute.
43. The method of any of claims 26 to 33, wherein the dose rate of said irradiation is about 7 to about 25 Mrad/minute.
44. The method of any of claims 26 to 33, wherein the dose rate of said irradiation is about 7 Mrad/minute.
45. The method of any of claims 26 to 30, 32 and 33, wherein the total absorbed dose of said irradiation is about 0.5 to about 1,000 Mrad.

- 61 -

46. The methods according to claims 26 to 30, 32, and 33, wherein said irradiating step delivers a dose of greater than about 20 MRad to said heated UHMWPE.

47. The method of any of claims 26 to 30, 32 and 33, wherein the total absorbed dose of said irradiation is about 1 to about 100 Mrad.

48. The method of any of claims 26 to 33, wherein the total absorbed dose of said irradiation is about 4 to about 30 Mrad.

49. The method of any of claims 26 to 33, wherein the total absorbed dose of said irradiation is about 20 Mrad.

50. The method of any of claims 26 to 33, wherein the total absorbed dose of said irradiation is about 15 Mrad.

51. The method of any of claims 26 to 33, wherein the total absorbed dose of said irradiation is about 5 Mrad to about 22 Mrad.

52. The method according to claim 31, wherein the UHMWPE is irradiated with electrons at a dose rate greater than about 4 Mrads/minute.

53. The method according to claims 31, wherein the UHMWPE is subjected to more than about 10 Mrads of irradiation.

54. The method according to claims 31, wherein the UHMWPE is subjected to more than 15 Mrads of irradiation.

55. The method according to claims 31, wherein the ultra high molecular weight polyethylene is subjected to UHMWPE is subjected to more than 20 Mrads of irradiation.

- 62 -

56. The method of claim 27 wherein said heated temperature of said UHMWPE is about 20°C to about 135°C.

57. The method of claim 27 wherein said heated temperature of said UHMWPE is about 50°C.

58. The method of claim 27 wherein said heating is done in a non-inert environment.

59. The method of claim 27 wherein said heating is done in an inert environment.

60. The method of claim 27 wherein said temperature of said UHMWPE prior to said irradiating step is about 100°C to about 135°C.

61. The method of claim 27 wherein said heated temperature of said UHMWPE prior to the irradiating step is about 120°C.

62. The method of claim 32 wherein said final temperature is about 137°C to about 300°C.

63. The method of claim 32 wherein said final temperature is about 145°C to about 190°C.

64. The method of claim 32 wherein said final temperature is about 150°C.

65. The method of claim 33 wherein said temperature of said UHMWPE after said additional heating is about 137°C to about 300°C.

66. The method of claim 33 wherein said temperature of said UHMWPE after said additional heating is about 145°C to about 190°C.

- 63 -

67. The method of claim 33 wherein said temperature of said UHMWPE after said additional heating is about 150°C.
68. The methods according to claim 29 or 30, further comprising surrounding said UHMWPE with an inert material that is substantially free of oxygen.
69. The method according to claim 31, wherein the provided UHMWPE is at or below room temperature.
70. The method according to claim 31, wherein the provided UHMWPE is at a temperature that is no higher than the melting temperature.
71. The method according to claim 70, wherein the provided UHMWPE is at a temperature of no more than 130°C.
72. The method according to claim 70, wherein the provided UHMWPE is at a temperature of no more than 120°C.
73. The method according to claim 31, wherein the provided UHMWPE is above room temperature.
74. The method of any of claims 26 to 73 further comprising the step of sterilizing said cooled UHMWPE.
75. The method of any of claims 26 to 73 wherein said UHMWPE in said providing step is selected from the group consisting of a bar stock, a shaped bar stock, a coating and a fabricated article.
76. The method of any of claims 26 to 73 wherein said UHMWPE in said providing step is a cup or tray shaped article for use in a prosthesis.

- 64 -

77. The method of any of claims 26 to 73 further comprising the step of machining said cooled UHMWPE.
78. The method of any of claims 26 to 73 wherein said UHMWPE in said providing step has an initial average molecular weight of greater than about 1 million.
79. The method of any of claims 26 to 73 wherein said irradiating step is done in a non-inert environment.
80. The method of any of claims 26 to 73 wherein said irradiating step is done in an inert environment.
81. The method of any of claims 26 to 73, wherein said irradiating step uses electron irradiation and the energy of the electrons is about 0.5 MeV to about 12 MeV.
82. The method of any of claims 26 to 73, wherein said cooling step is at a rate greater than about 0.1°C/minute.
83. The method of any of claims 26 to 73, wherein said cooling step is at a rate greater than about 0.5°C/mm.
84. The method of any of claims 26 to 73, wherein said cooling step is at a rate of about 0.5°C/mm.
85. The method of any of claims 26 to 73, wherein said UHMWPE in step (a) is in an insulating material so as to reduce heat loss from said UHMWPE during processing.
86. The method of any of claims 26 to 73, wherein step (b) uses electron irradiation.
87. A method of making a medical prosthesis from radiation treated ultra high molecular weight polyethylene (UHMWPE) having multiple melting peaks, said prosthesis resulting in the reduced

- 65 -

production of particles from said prosthesis during wear of said prosthesis, comprising the steps of:

a) providing radiation treated UHMWPE having multiple melting peaks, wherein the UHMWPE has a tensile elastic modulus of less than about 940 MPa, and wherein the UHMWPE is substantially oxidation resistant; and

b) forming a medical prosthesis from said UHMWPE so as to reduce production of particles from said prosthesis during wear of said prosthesis, said UHMWPE forming a load bearing surface of said prosthesis.

88. A method of making a medical prosthesis from radiation treated ultra high molecular weight polyethylene (UHMWPE), said prosthesis resulting in the reduced production of particles from said prosthesis during wear of said prosthesis, comprising the steps of:

a) providing UHMWPE that has been irradiated above room temperature at a dose rate of at least 2 Mrads/hour, wherein the UHMWPE has a tensile elastic modulus of less than about 940 MPa, and wherein the UHMWPE is substantially oxidation resistant; and

b) forming a medical prosthesis from said UHMWPE so as to reduce production of particles from said prosthesis during wear of said prosthesis, said UHMWPE forming a load bearing surface of said prosthesis.

89. A method of making a medical prosthesis from radiation treated ultra high molecular weight polyethylene (UHMWPE) having multiple melting peaks, said prosthesis resulting in the reduced production of particles from said prosthesis during wear of said prosthesis, comprising the steps of:

- 66 -

a) providing radiation treated UHMWPE having multiple melting peaks made by the method of claim any of claims 26 to 74; and

b) forming a medical prosthesis from said UHMWPE so as to reduce production of particles from said prosthesis during wear of said prosthesis, said UHMWPE forming a load bearing surface of said prosthesis.

90. The method of claims 88 or 89, wherein said UHMWPE has a polymeric structure with less than about 50% crystallinity, and less than about 940 MPa tensile elastic modulus.

91. A method of making a medical prosthesis from radiation treated ultra high molecular weight polyethylene (UHMWPE), said prosthesis resulting in the reduced production of particles from said prosthesis during wear of said prosthesis, comprising the steps of:

a) providing UHMWPE that has been irradiated above room temperature at a dose rate of at least 4 Mrads/hour, wherein the UHMWPE has a tensile elastic modulus of less than about 940 MPa, and wherein the UHMWPE is substantially oxidation resistant; and

b) forming a medical prosthesis from said UHMWPE so as to reduce production of particles from said prosthesis during wear of said prosthesis, said UHMWPE forming a load bearing surface of said prosthesis.

92. A use of radiation treated ultra high molecular weight polyethylene (UHMWPE) having multiple melting peaks to form a medical prosthesis, wherein said UHMWPE is prepared by:

- 67 -

a) providing UHMWPE, wherein the UHMWPE has a tensile elastic modulus of less than about 940 MPa, and wherein the UHMWPE is substantially oxidation resistant;

b) irradiating the UHMWPE above room temperature at a dose rate of at least 2 Mrads/hour; and

c) forming said radiation treated UHMWPE having multiple melting peaks into said prosthesis.

93. A use of radiation treated ultra high molecular weight polyethylene (UHMWPE) having multiple melting peaks to form a medical prosthesis, wherein said UHMWPE is prepared by:

a) providing radiation treated UHMWPE having multiple melting peaks made by the method of claim any of claims 26 to 74; and

b) forming said radiation treated UHMWPE having multiple melting peaks into said prosthesis.

94. The use of claim 92 or 93, wherein said radiation treated UHMWPE has a polymeric structure with less than about 50% crystallinity, and less than about 940 MPa tensile elastic modulus.

95. A medical prosthesis for use within a body, wherein said prosthesis comprises cross-linked ultra high molecular weight polyethylene (UHMWPE) having a polymeric structure with less than about 50% crystallinity less than about 940 MPa tensile elastic modulus, and substantial oxidation resistance, so as to reduce production of fine particles from said prosthesis during wear of said prosthesis.

- 68 -

96. A method for making a fabricated article that comprises cross-linked ultra high molecular weight polyethylene (UHMWPE) having substantially no detectable free radicals, wherein the method comprises:

a) providing UHMWPE having polymeric chains, wherein the UHMWPE is at a temperature equal to or above its melting point;

b) irradiating said UHMWPE so as to cross-link said polymeric chains;

c) cooling said heated UHMWPE, wherein the UHMWPE has a tensile elastic modulus of less than about 940 MPa, and wherein the UHMWPE is substantially oxidation resistant; and

d) machining said cooled UHMWPE.

97. The method of claim 96, wherein said fabricated article is a medical prosthesis.

98. A method for making a cross-linked ultra high molecular weight polyethylene (UHMWPE), comprising the steps of:

a) providing UHMWPE having polymeric chains, wherein the UHMWPE is at a temperature that is below its melting point;

b) irradiating the UHMWPE so as to cross-link said polymeric chains and to generate sufficient heat to at least partially melt the UHMWPE; and

c) cooling said heated UHMWPE, wherein the UHMWPE has a tensile elastic modulus of less than about 940 MPa.

- 69 -

99. The method according to claim 98, wherein the UHMWPE is heated to at least to its melting point in order to substantially eliminate free radicals.

100. The method according to claim 99, wherein the irradiation melts the UHMWPE.

101. The method according to claim 99, wherein a heating source in addition to radiation melts the UHMWPE.

1/5

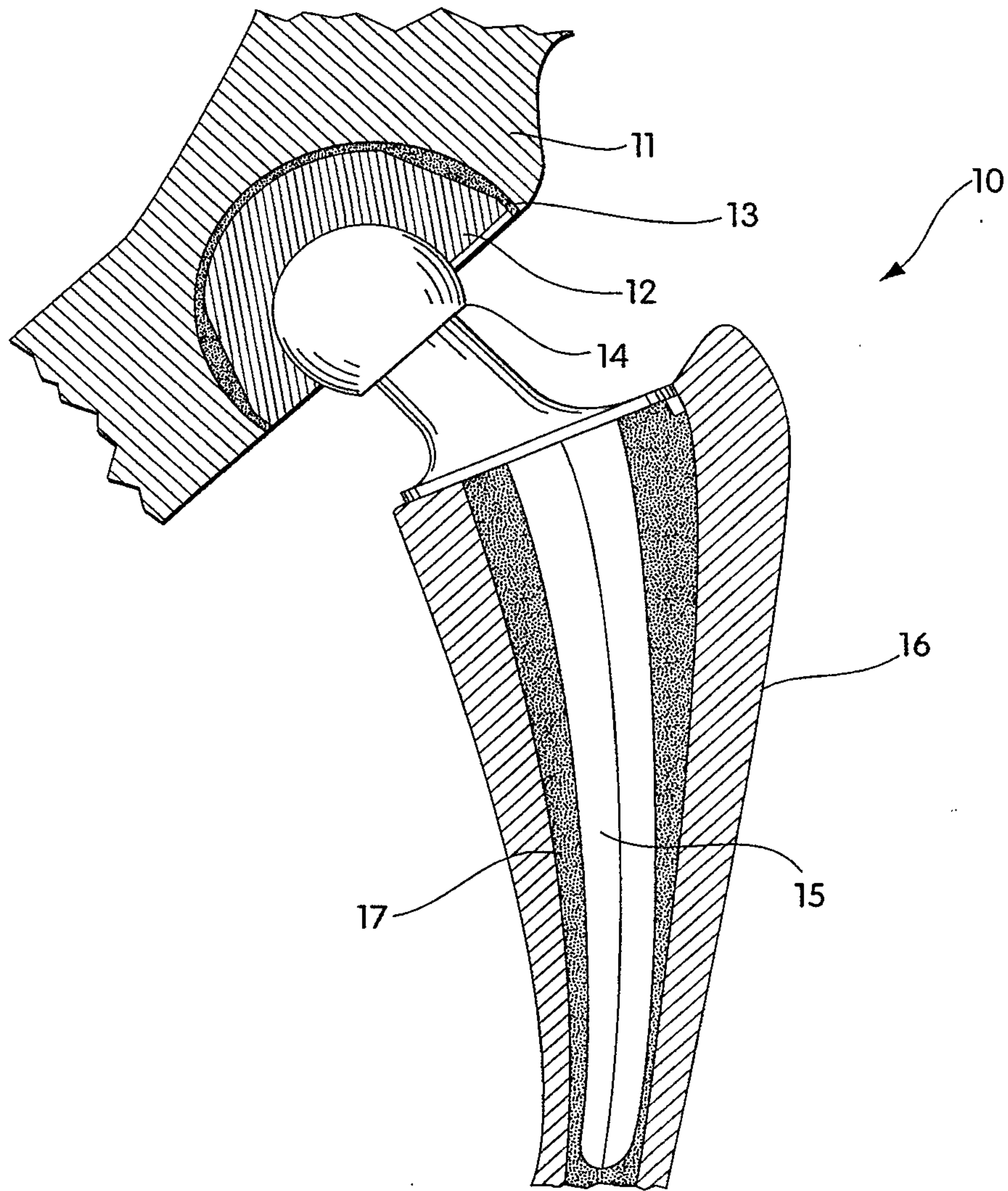

Fig. 1

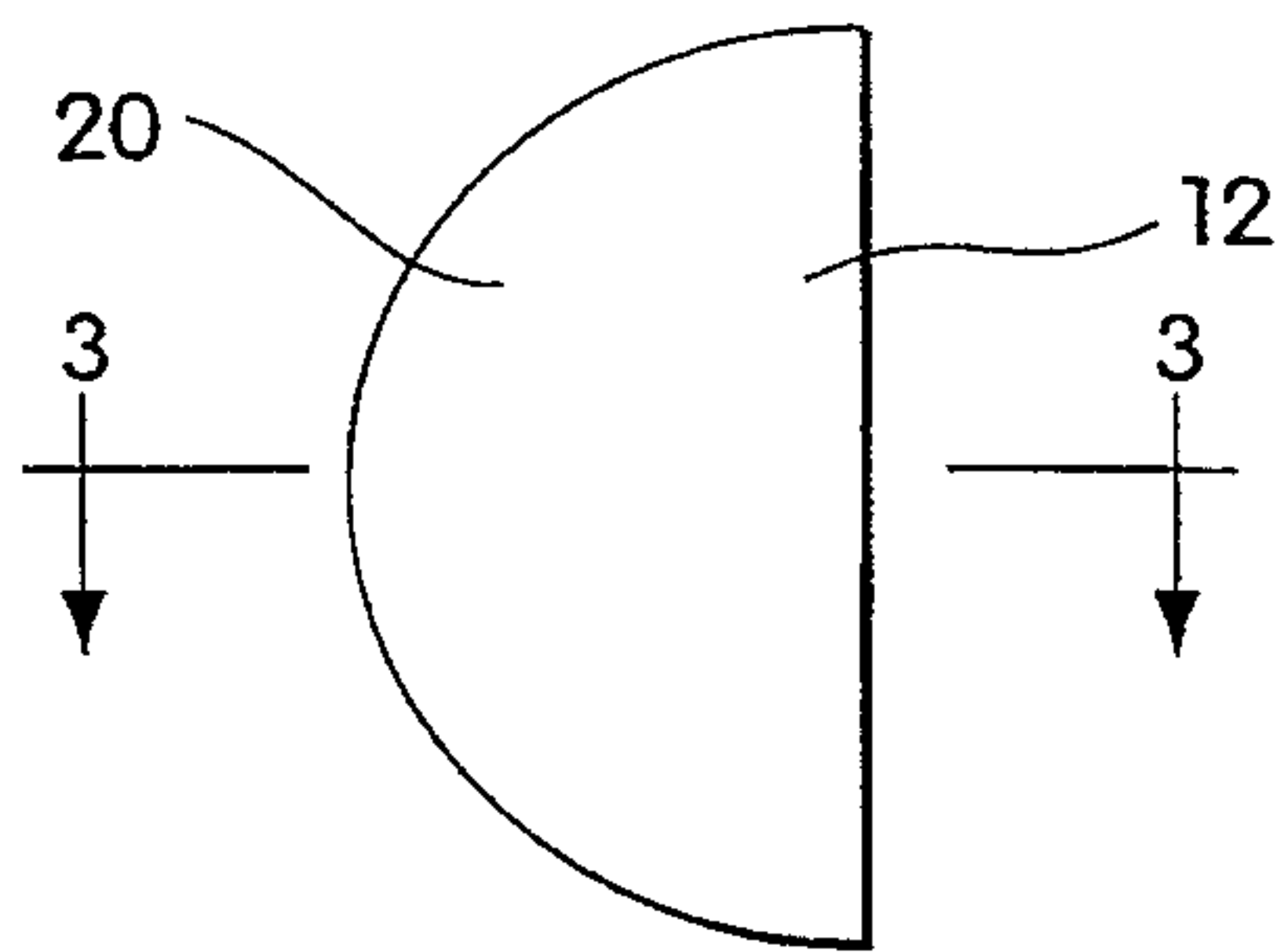

Fig. 2

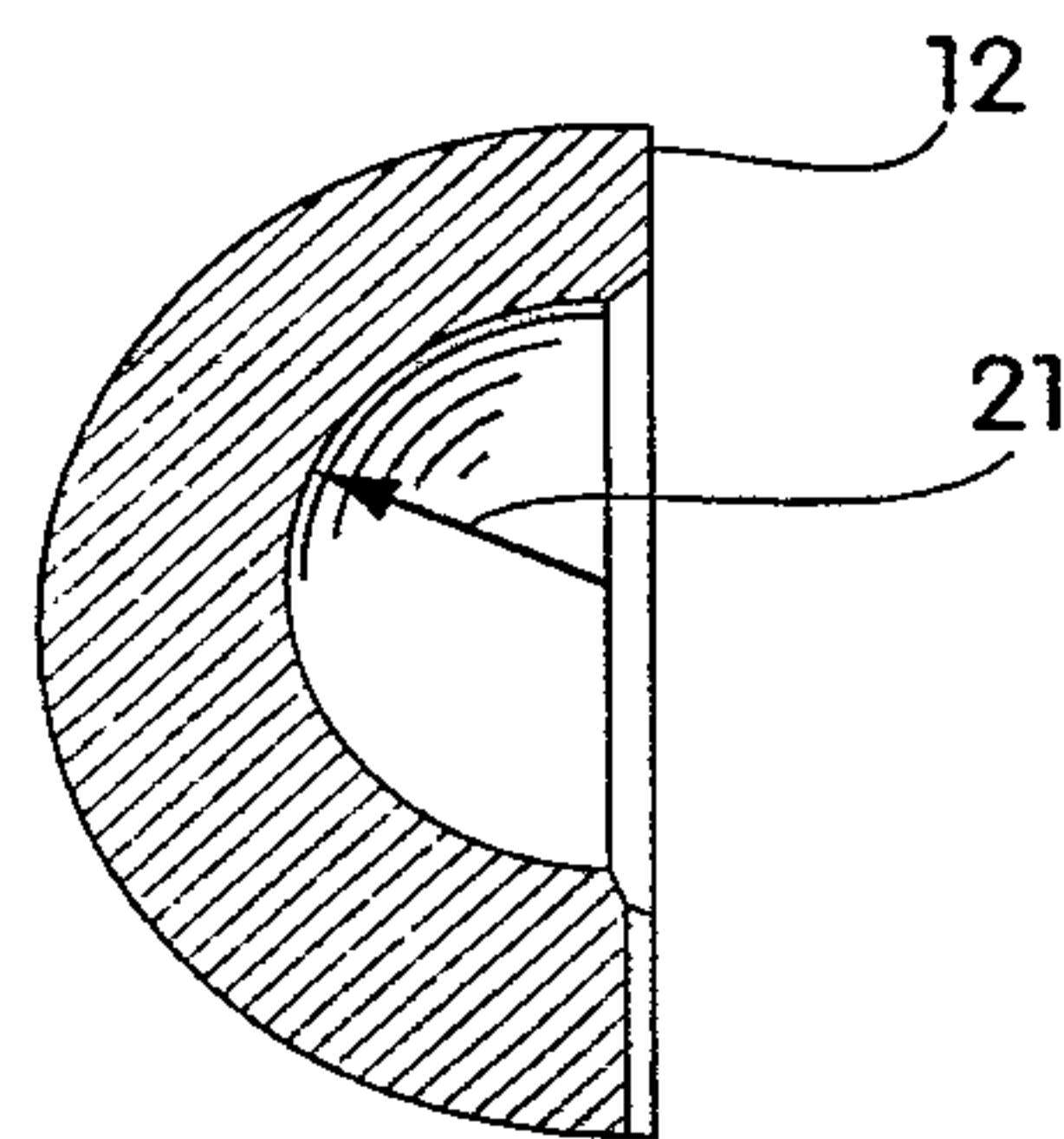

Fig. 3

2/5

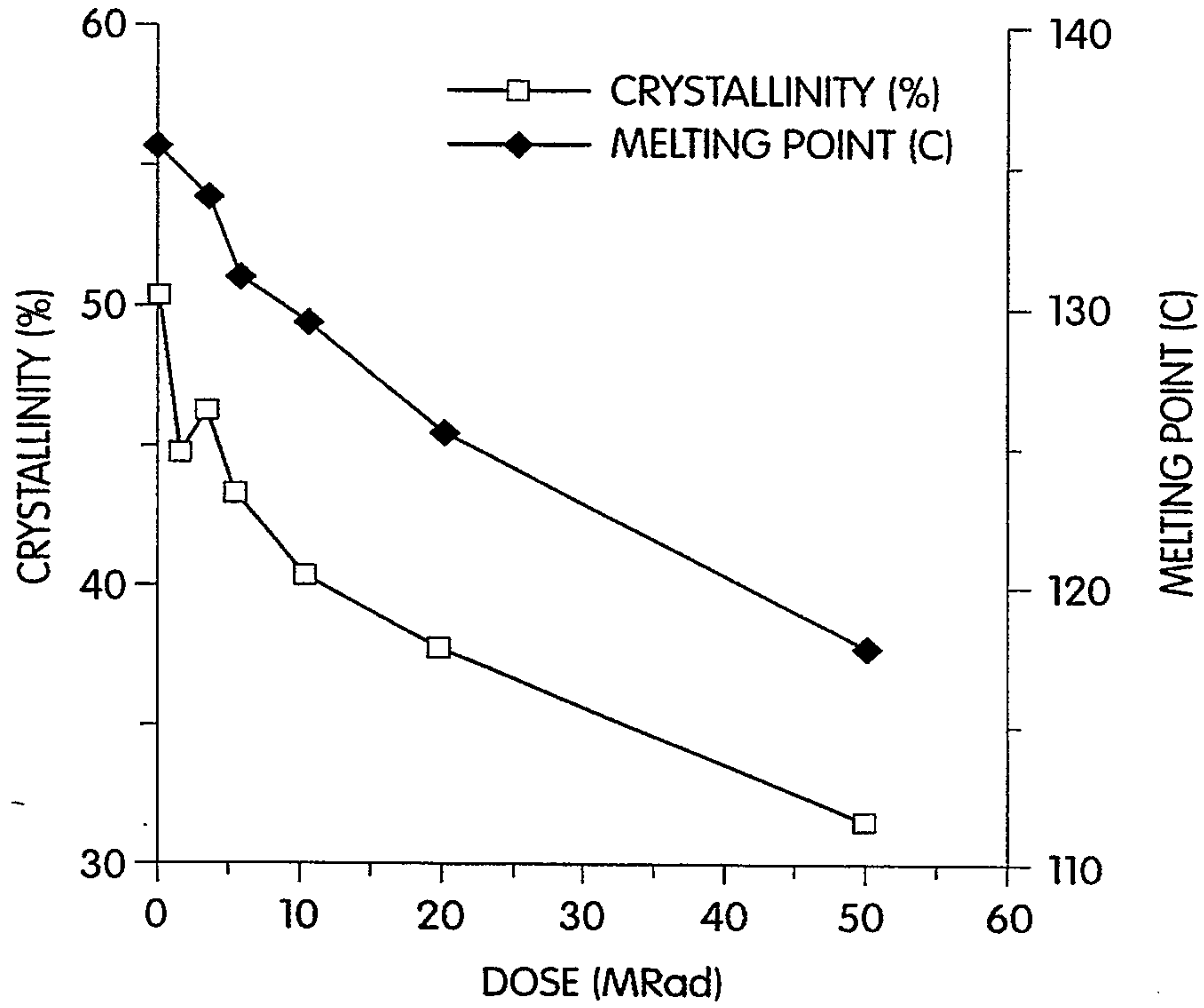

Fig. 4

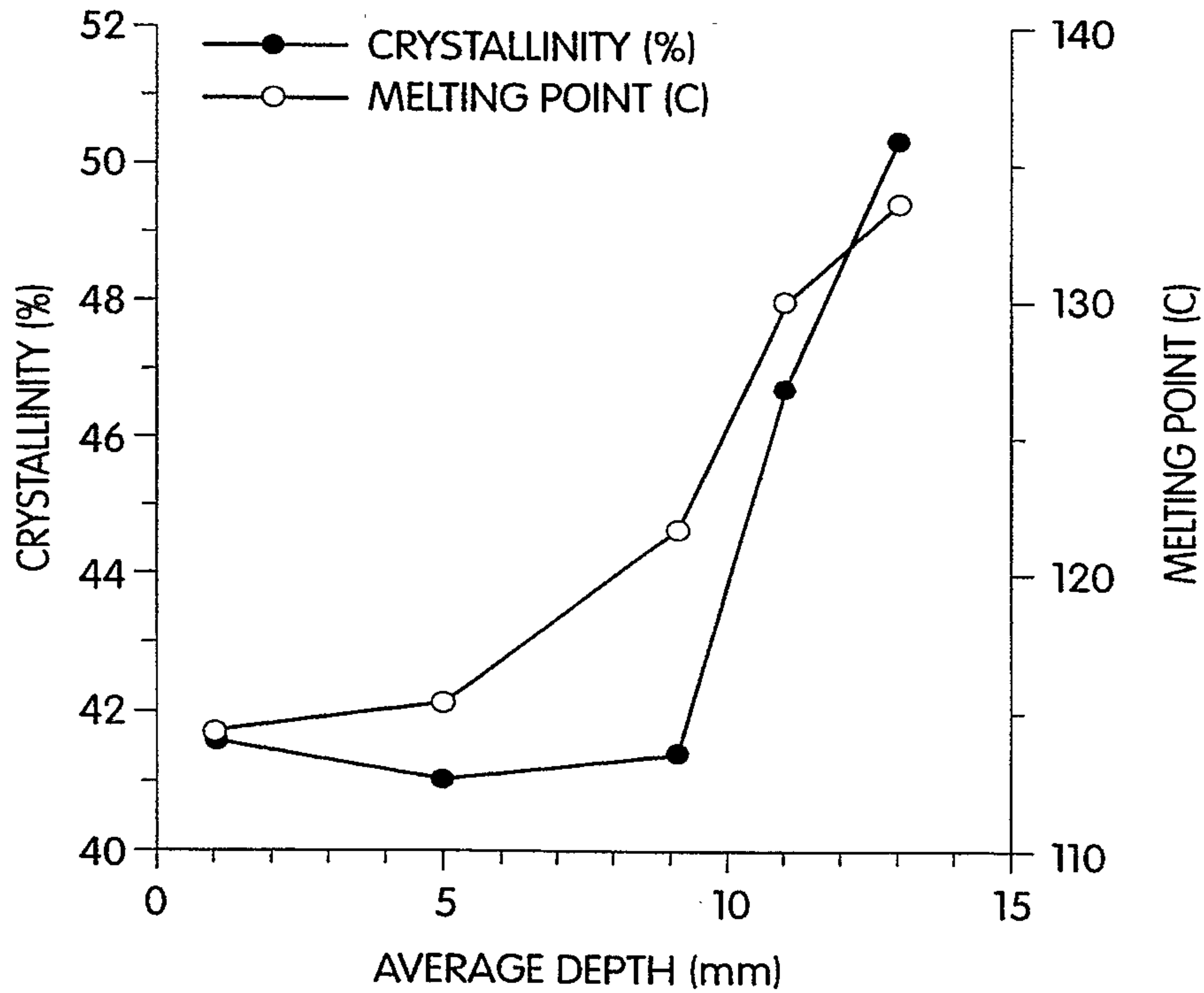

Fig. 7  
SUBSTITUTE SHEET (RULE 26)

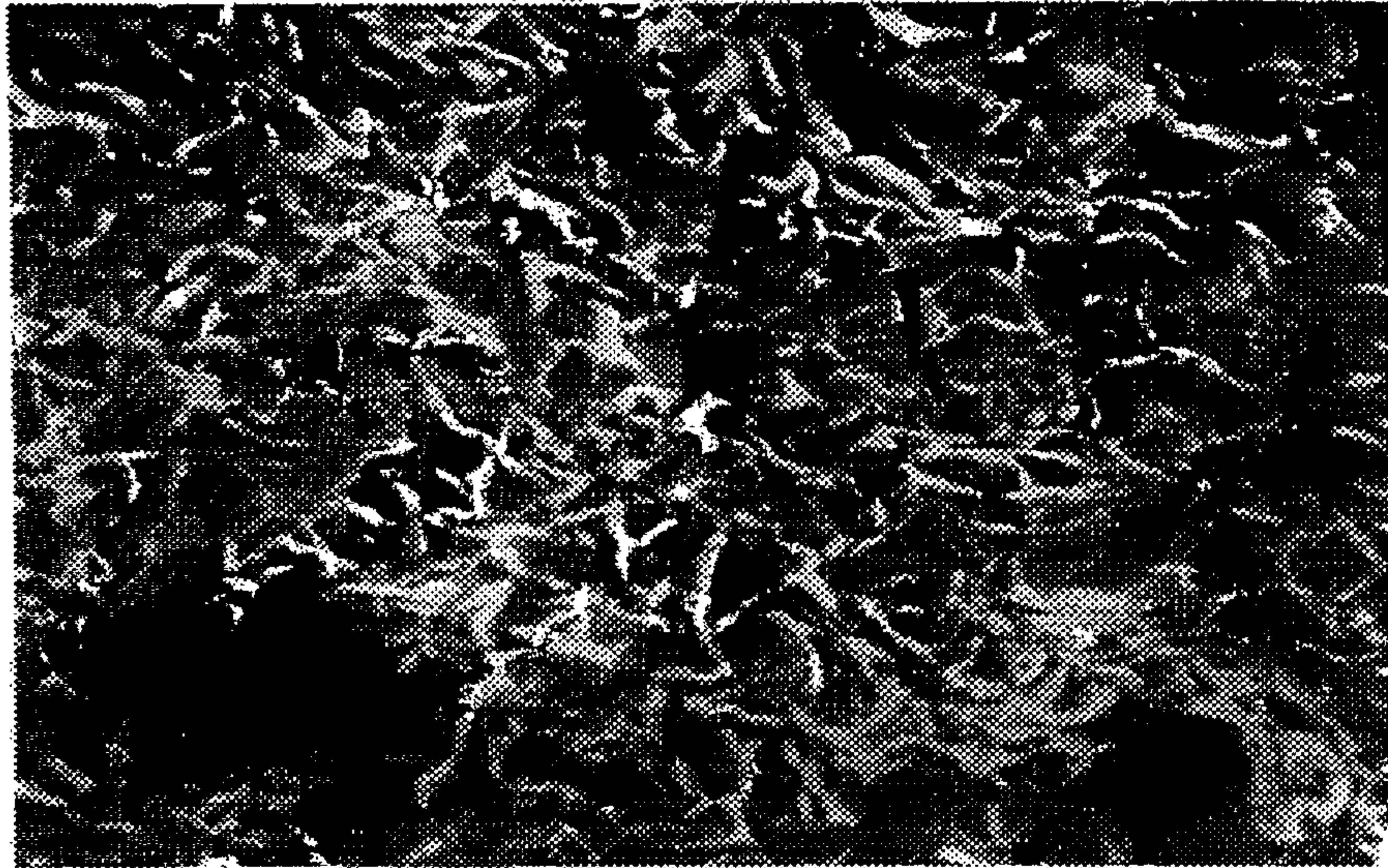

Fig. 5



Fig. 6  
SUBSTITUTE SHEET (RULE 26)

4/5

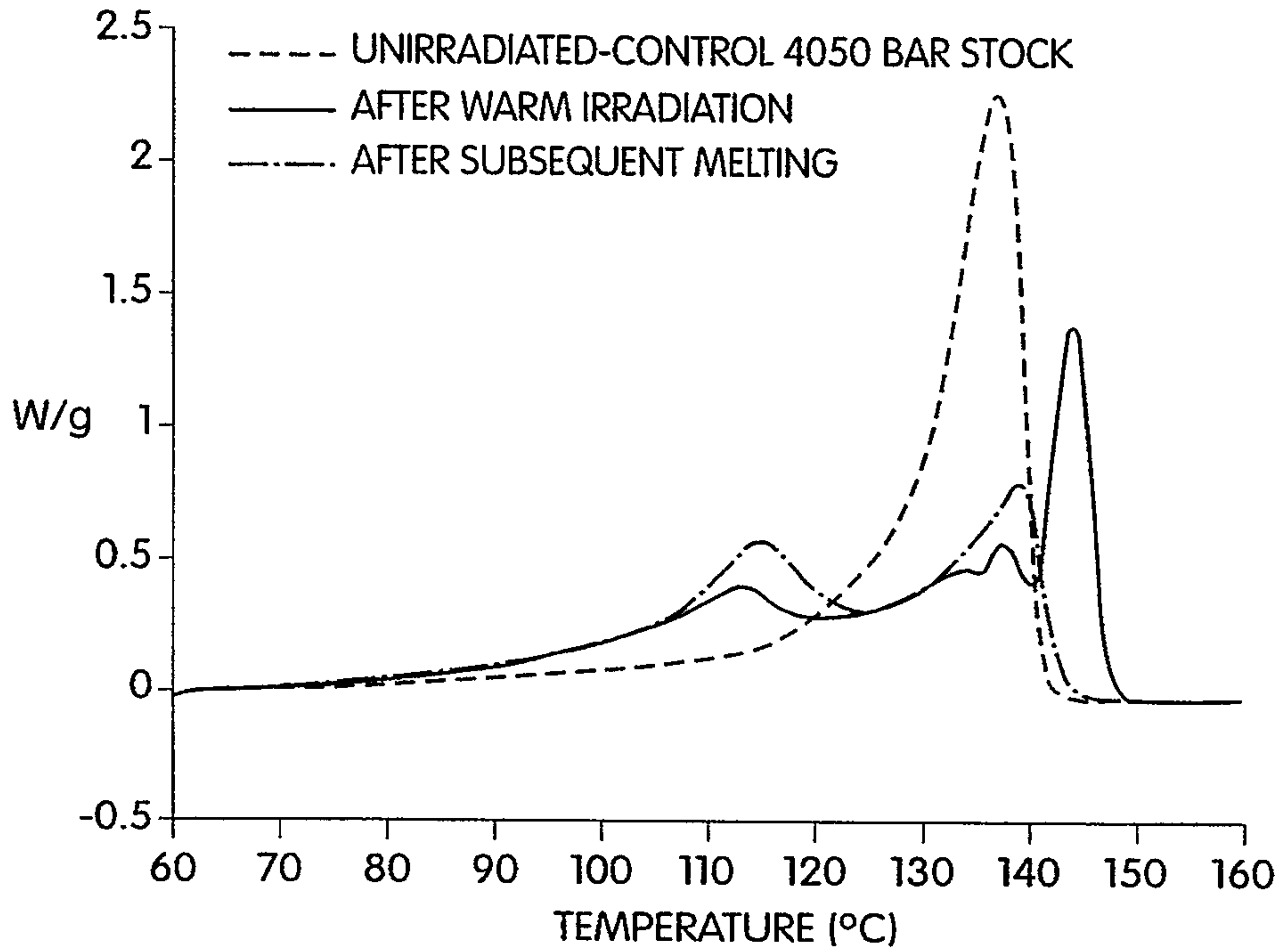

Fig. 8

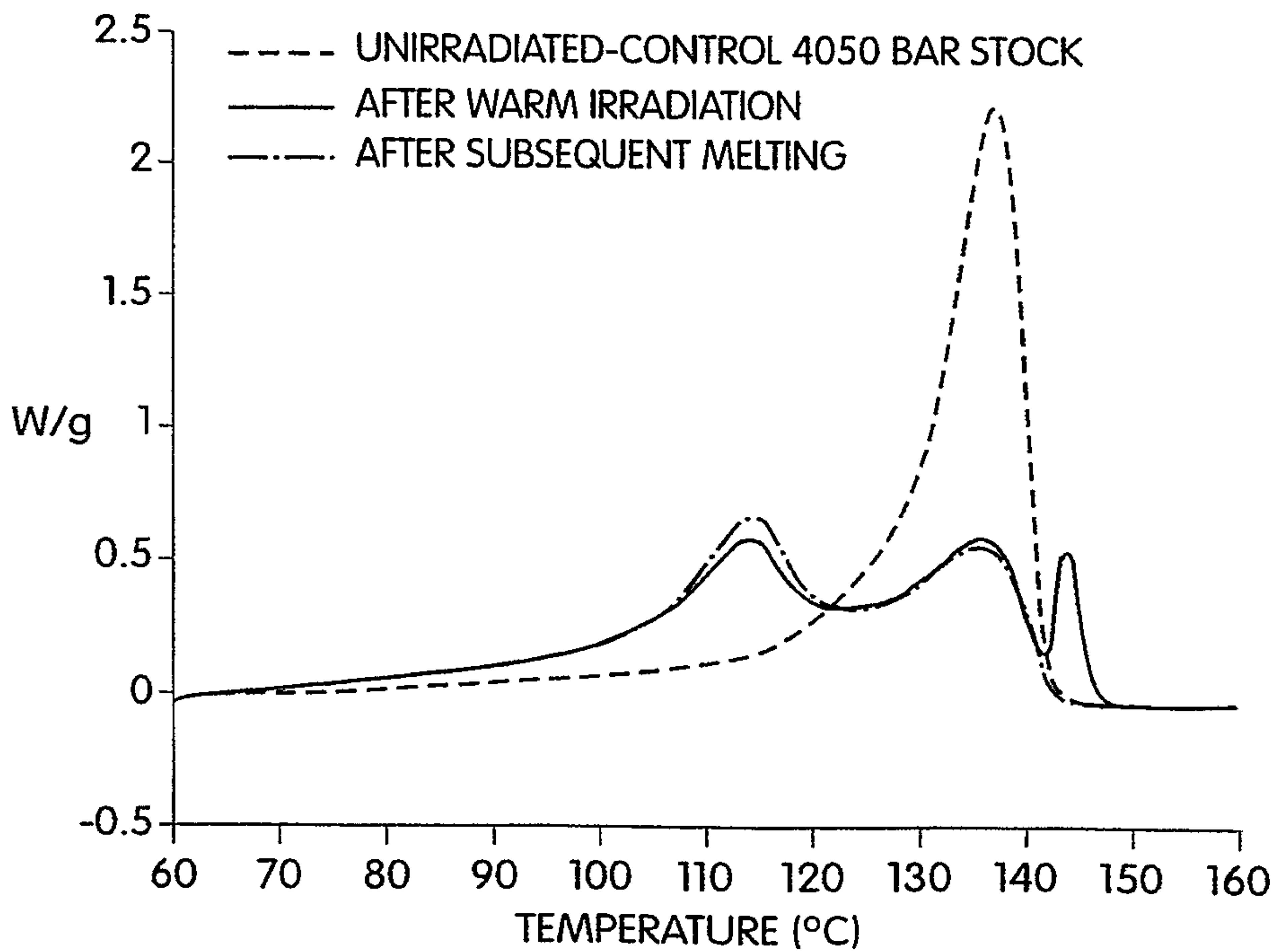

Fig. 9

5/5

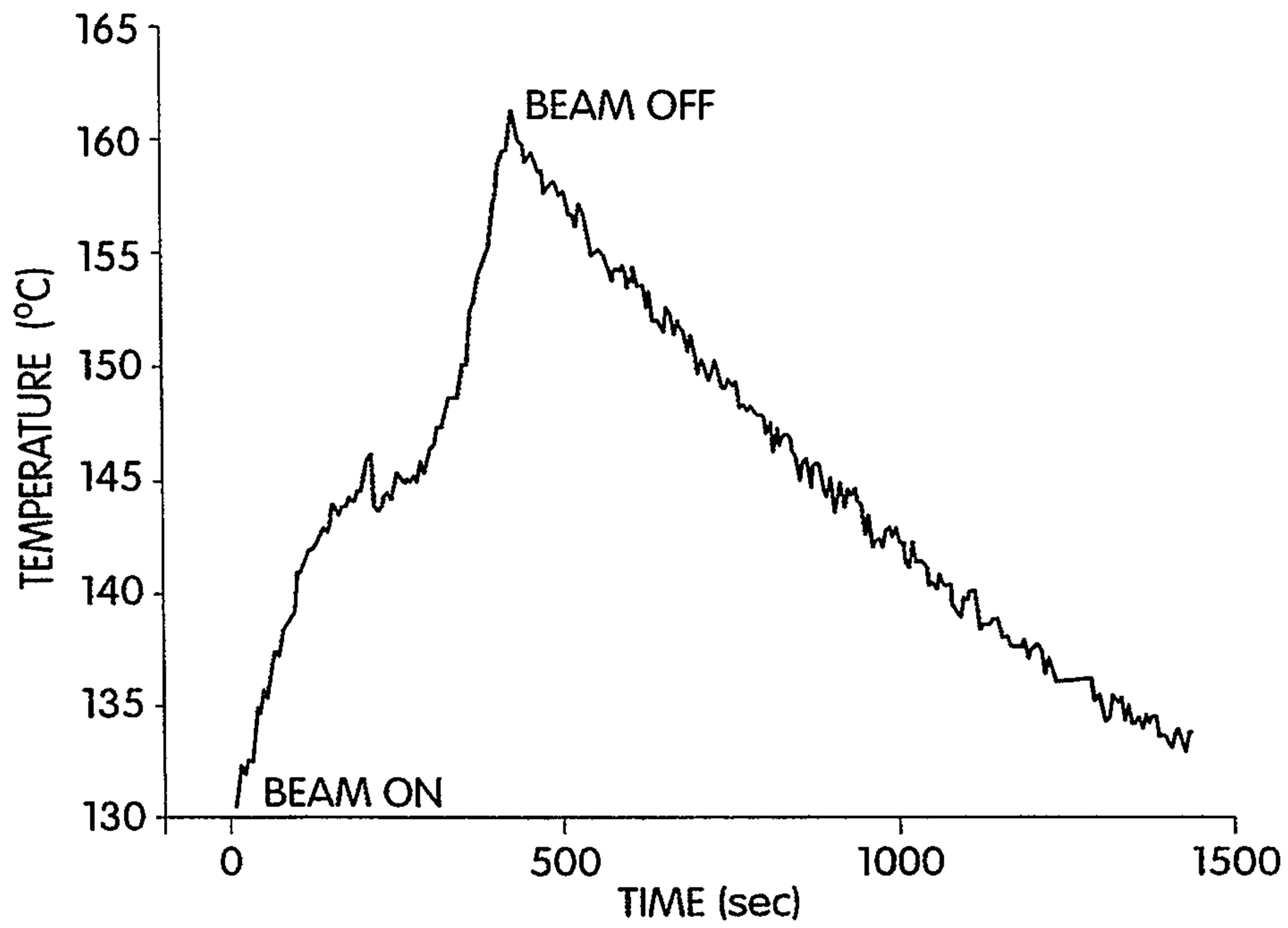

Fig. 10

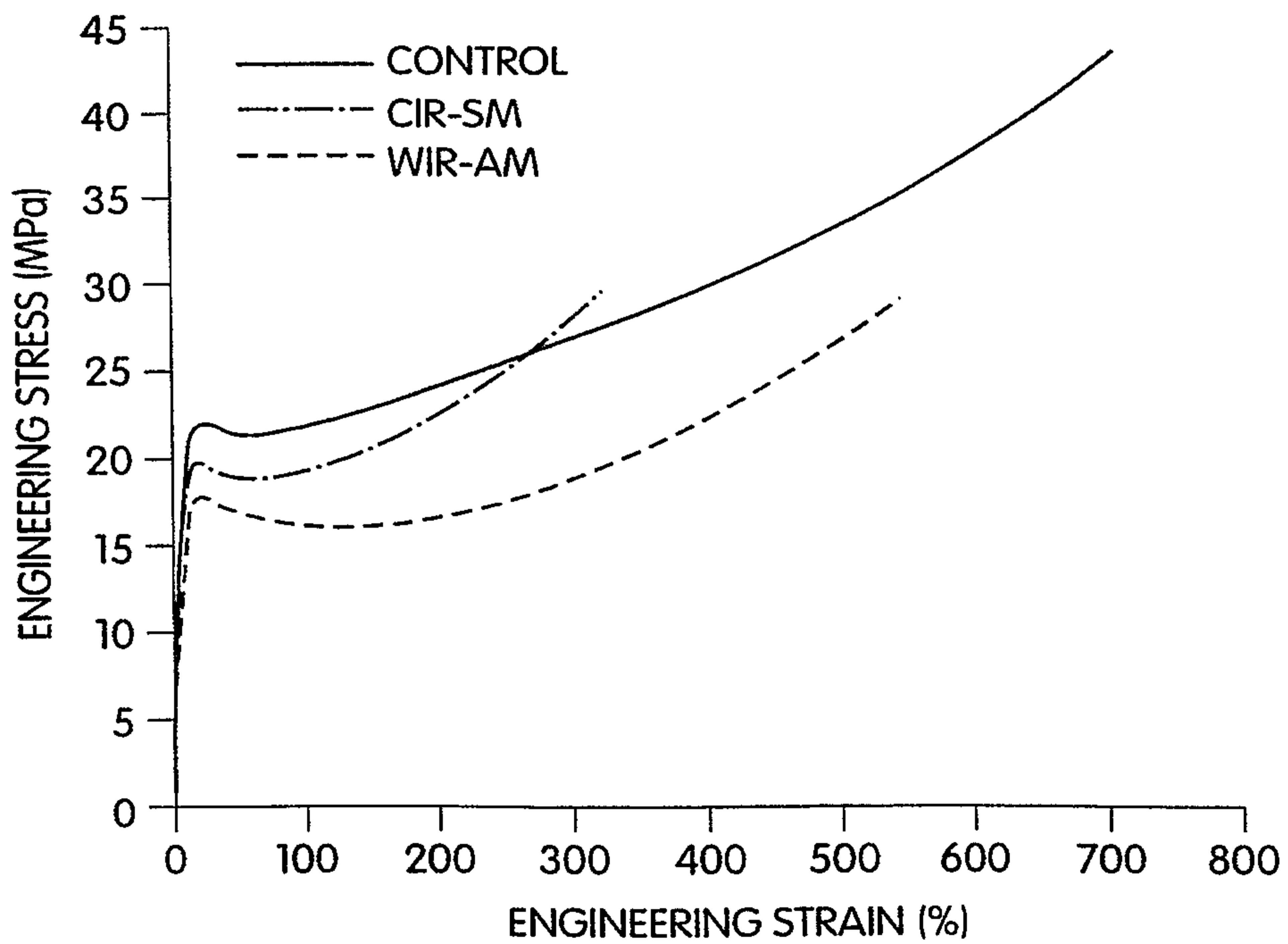

Fig. 11

