

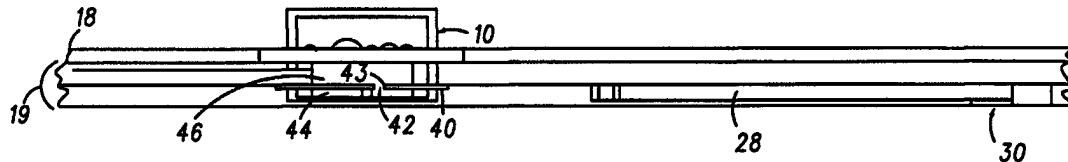

INTERNATIONAL APPLICATION PUBLISHED UNDER THE PATENT COOPERATION TREATY (PCT)

<p>(51) International Patent Classification ⁶ : F28F 7/00, F28D 15/00, H01L 23/34, H05K 7/20</p>	<p>A1</p>	<p>(11) International Publication Number: WO 98/44307 (43) International Publication Date: 8 October 1998 (08.10.98)</p>
<p>(21) International Application Number: PCT/US98/03648 (22) International Filing Date: 25 February 1998 (25.02.98) (30) Priority Data: 08/829,565 31 March 1997 (31.03.97) US (71) Applicant: MOTOROLA INC. [US/US]; 1303 East Algonquin Road, Schaumburg, IL 60196 (US). (72) Inventors: MORRIS, Garron, K.; 1940 Sherman Avenue #103, Evanston, IL 60201 (US). SCHMIDT, Detlef, W.; 1417 Harvard Lane, Schaumburg, IL 60193 (US). SMITH, John, M.; 9N556 Nokomis Lane, Elgin, IL 60123 (US). (74) Agents: CREPS, Heather, L. et al.; Motorola Inc., Intellectual Property Dept., 1303 East Algonquin Road, Schaumburg, IL 60196 (US).</p>		<p>(81) Designated States: AU, BR, CA, CN, JP, KR, MX, SG, European patent (AT, BE, CH, DE, DK, ES, FI, FR, GB, GR, IE, IT, LU, MC, NL, PT, SE). Published <i>With international search report.</i></p>

(54) Title: APPARATUS AND METHOD FOR COOLING AN ELECTRONIC HEAT SOURCE



(57) Abstract

According to an aspect of the present invention, the foregoing needs are addressed by an apparatus for cooling a heat source (10), including a carrier plate (19) having a channel (28, 38) therein. The channel has an inlet end (30) and an outlet end (31). A cooling region (46) is disposed in the carrier plate and is in communication with the channel. The cooling region is sized to be disposed proximate the heat source. A member (40) having an orifice (42) therein is disposed in the cooling region. A ratio between a thickness of the member and a width of the orifice is less than 0.9.

FOR THE PURPOSES OF INFORMATION ONLY

Codes used to identify States party to the PCT on the front pages of pamphlets publishing international applications under the PCT.

AL	Albania	ES	Spain	LS	Lesotho	SI	Slovenia
AM	Armenia	FI	Finland	LT	Lithuania	SK	Slovakia
AT	Austria	FR	France	LU	Luxembourg	SN	Senegal
AU	Australia	GA	Gabon	LV	Latvia	SZ	Swaziland
AZ	Azerbaijan	GB	United Kingdom	MC	Monaco	TD	Chad
BA	Bosnia and Herzegovina	GE	Georgia	MD	Republic of Moldova	TG	Togo
BB	Barbados	GH	Ghana	MG	Madagascar	TJ	Tajikistan
BE	Belgium	GN	Guinea	MK	The former Yugoslav Republic of Macedonia	TM	Turkmenistan
BF	Burkina Faso	GR	Greece	ML	Mali	TR	Turkey
BG	Bulgaria	HU	Hungary	MN	Mongolia	TT	Trinidad and Tobago
BJ	Benin	IE	Ireland	MR	Mauritania	UA	Ukraine
BR	Brazil	IL	Israel	MW	Malawi	UG	Uganda
BY	Belarus	IS	Iceland	MX	Mexico	US	United States of America
CA	Canada	IT	Italy	NE	Niger	UZ	Uzbekistan
CF	Central African Republic	JP	Japan	NL	Netherlands	VN	Viet Nam
CG	Congo	KE	Kenya	NO	Norway	YU	Yugoslavia
CH	Switzerland	KG	Kyrgyzstan	NZ	New Zealand	ZW	Zimbabwe
CI	Côte d'Ivoire	KP	Democratic People's Republic of Korea	PL	Poland		
CM	Cameroon	KR	Republic of Korea	PT	Portugal		
CN	China	KZ	Kazakstan	RO	Romania		
CU	Cuba	LC	Saint Lucia	RU	Russian Federation		
CZ	Czech Republic	LI	Liechtenstein	SD	Sudan		
DE	Germany	LK	Sri Lanka	SE	Sweden		
DK	Denmark	LR	Liberia	SG	Singapore		
EE	Estonia						

**APPARATUS AND METHOD FOR COOLING AN ELECTRONIC
HEAT SOURCE**

Field of the Invention

This invention relates generally to cooling heat sources, and, more particularly, to an apparatus and method for cooling an electronic heat source.

Background of the Invention

Electronic components such as integrated circuits, multi-chip modules, passive components and power transistors, which are generally mounted to surfaces such as circuit boards, may be heat sources which require cooling during normal operation as well as during testing and tuning.

Traditionally, electronic components have been cooled by natural or forced air convection which involves moving large volumes of air past the components or past heavy heat sinks attached to the components. Advances in electronic devices, however, have resulted in some electronic devices having power densities which exceed the capabilities of traditional natural or forced convective air cooling.

Evaporative spray cooling, cold plates and jet impingement cooling are examples of thermal management techniques which use liquid coolants, rather than air, to dissipate heat generated by electronic components.

Evaporative spray cooling, or two-phase cooling, features the spraying of atomized fluid droplets directly or indirectly onto a surface of a heat source such as an electronic component. When the fluid droplets impinge upon the component's surface, a thin film of liquid coats the component, and heat is removed

-2-

primarily by evaporation of the fluid from the component's surface.

Although evaporative spray cooling is a method of heat removal in many electronics applications, this cooling technique may require the use of expensive dielectric liquids. And because fluid is typically sprayed directly onto the surfaces of electronic components, the fluid may capture particulate matter from the electronic components, such as flux residue, which may clog spray nozzles and impede the effective spraying of the fluid. In addition, extensive sealing may be required prior to operation of a spray-cooling system, so that operation of the cooling system during the testing and tuning process of electronic components may be impractical.

The cold plate is typically a direct replacement for an air-cooled heat sink in which water or another fluid flows through internal passages where the heat sink was originally mounted. This technique cools the whole surface of an electronic module, rather than primary heat sources, such as individual electronic components, located on the surface of the module. And the complexity of flow passages in cold plates may makes it difficult to accurately predict heat transfer characteristics. Moreover, the heat transfer capabilities of cold plates are much less than those achievable using spray cooling, because heat typically must pass through several interfaces before reaching the fluid in the cold plate. Consequently, high flow rates (up to several gallons per minute) may be required for successful application of cold plate technology.

There is therefore a need for an apparatus and method for cooling a heat source such as an electronic component which, among other things, does not require the heat source to be in contact with the cooling fluid and does not require a phase change operation, which

-3-

cools only the heat generating portion of the electronic component, which features low flow rates and which allows the electronic component to be cooled during the testing and tuning process.

Summary of the Invention

According to an aspect of the present invention, the foregoing needs are addressed by an apparatus for cooling a heat source, including a carrier plate having a channel therein. The channel has an inlet end and an outlet end. A cooling region is disposed in the carrier plate and is in communication with the channel. The cooling region is sized to be disposed proximate the heat source. A member having an orifice therein is disposed in the cooling region. A ratio between a width of the orifice and a thickness of the member is less than 0.9.

According to another aspect of the present invention, an apparatus for cooling an electronic component mounted to a substrate is disclosed. The substrate has a first side and a second side and the electronic component is mounted to the first side. The apparatus includes a carrier plate coupled to the second side. The carrier plate has a first fluid distributing channel and a second fluid distributing channel therein. The first fluid distributing channel is in communication with a fluid inlet port and the second fluid distributing channel is in communication with a fluid outlet port. A first fluid receiving area, defining a first chamber, is disposed in the carrier plate and is in communication with the first fluid distributing channel. A second fluid receiving area, defining a second chamber, is disposed in the carrier plate and in communication with the second fluid distributing

-4-

channel. The second fluid receiving area substantially aligned with the electronic component. A plate having an orifice therein is disposed between the first chamber and the second chamber. A ratio between a thickness of the plate and a width of the orifice and is less than 0.9. The first fluid distribution channel receives a fluid from the fluid inlet port and conveys the fluid to the first chamber. The orifice accelerates the fluid and discharges the fluid into the second chamber and toward the second side of the substrate. The second fluid distribution channel receives the fluid from the second chamber and supplies the fluid to the fluid outlet port.

According to a further aspect of the present invention, a method for cooling a heat source includes providing a carrier plate having a channel therein, the channel having an inlet end and an outlet end; disposing a cooling region proximate the heat source, the cooling region disposed in the carrier plate and in communication with the channel; disposing a plate having an orifice therein within the cooling region, a ratio between a thickness of the plate and a width of the orifice being less than 0.9, the plate defining a first chamber and a second chamber within the cooling region; receiving a fluid by the inlet end; distributing the fluid to the first chamber; the orifice accelerating the fluid and discharging the fluid into the second chamber; and the outlet end removing the fluid from the second chamber.

Advantages of the present invention will become readily apparent to those skilled in the art from the following description of the preferred embodiment(s) of the invention which have been shown and described by way of illustration. As will be realized, the invention is capable of other and different embodiments, and its details are capable of modifications in various

-5-

respects. Accordingly, the drawings and description are to be regarded as illustrative in nature, and not as restrictive.

Brief Description of the Drawings

FIG. 1 is a perspective view of a typical electronic component.

FIG. 2 is a front view along line 2-2 of the electronic component depicted in FIG. 1, illustrating a typical manner of mounting the component to a substrate.

FIG. 3 is a perspective view of the electronic component mounted as shown in FIG. 2, further depicting a disassembled apparatus for cooling the electronic component according to a preferred embodiment of the present invention.

FIG. 4 is a side-view of the fully-assembled apparatus shown in FIG. 3.

FIG. 5 illustrates operation of the apparatus shown in FIG. 4 in conjunction with a cooling system having a closed-loop fluid flow, according to a preferred embodiment of the present invention.

FIG. 6 illustrates the vena contracta phenomenon, which occurs during operation of the cooling system shown in FIG. 5.

Detailed Description of the Preferred Embodiments

Turning now to the drawings, wherein like numerals designate like components, FIG. 1 is a perspective view of a typical electronic component **10**. Component **10** includes a number of terminals **14**, a base **17**, a cover **16** and one or more dies (not shown), which are protected by cover **16**.

Electronic component **10** may be, for example, an NPN Silicon Radio Frequency (RF) Power Transistor, such as a

-6-

flangeless RF power transistor, available from Motorola, order number SRF701. References to electronic component **10** will be understood to apply not only to component **10** as depicted in FIG. 1, but also to differently-configured power transistors such as a flanged RF power transistor, available from Motorola, order number MRF899, and to completely different components, including but not limited to passive components, all types of integrated circuits, multi-chip modules and hybrid circuits.

FIG. 2 is a front view along line 2-2 of electronic component **10** depicted in FIG. 1, illustrating a typical manner of electrically connecting component **10** to a substrate **18**. Substrate **18** comprises one or more layers of glass-filled epoxy, teflon, alumina, ceramic or plastic.

Base **17** of component **10** extends at least in part through substrate **18**. Terminals **14** may be attached to substrate **18** or to a device (not shown) located on substrate **18** in a variety of ways, such as soldering or conductive epoxy. Second side **21** of substrate **18** may be attached to a carrier plate (discussed further below).

FIG. 3 is a perspective view of the electronic component mounted as shown in FIG. 2, further depicting a disassembled apparatus for cooling the electronic component, according to a preferred embodiment of the present invention. A carrier plate **19**, to which second side **21** of substrate **18** is attached in accordance with a preferred embodiment of the present invention, includes two layers **24** and **26**.

Layer **24** includes a fluid inlet port **30**, a fluid distributing channel **28**, a fluid receiving area **32** and a fluid outlet port **31**. Fluid receiving area **32** is preferably located substantially under electronic component **10**.

-7-

Layer **26** includes a fluid receiving area **36** and a fluid distributing channel **38**. Fluid receiving area **36** is preferably located substantially under electronic component **10**.

A plate **40**, or member, having one or more orifices **42** (one shown) therein is installed between layers **24** and **26**. Plate **40** is preferably Aluminum Silicon Carbide (AlSiC), plastic or stainless steel, but may be any other suitable material. Orifice **42** may be any geometrical shape, including round or rectangular or another suitable shape. Preferably, a ratio of a thickness of plate **40** and a width (or a diameter) of orifice **42** is less than 0.9, and edges **43** of orifice **42** facing fluid receiving area **32** are sharp rather than rounded.

Layers **24** and **26** also include a number of vias **34**, which may be used, for example, for securing substrate **18** to layer **26**, and/or to attach the complete assembly to its mounting surface. Layers **24** and **26** are preferably permanently secured by brazing, but may be attached using various other methods, including but not limited to well-known techniques such as fasteners, compliant gaskets, ultrasonic welding, brazing, soldering or swaging and others.

Carrier plate **19** is made, for example, of copper, AlSiC, plastic or graphite. Although carrier plate **19** is shown as two layers **24** and **26**, it is contemplated that carrier plate **19** may be a single piece, and that orifice **42** may be formed simultaneously with carrier plate **19** using well-known casting techniques.

As can be seen in FIG. 4, an assembled side view of the apparatus shown in FIG. 3, fluid receiving area **32** and plate **40** define a chamber **44** in the region below plate **40**, while fluid receiving area **36** and plate **40** define a chamber **46** in the region above plate **40**.

-8-

FIG. 5 depicts operation of a closed-loop system for cooling electronic component **10**, according to a preferred embodiment of the present invention. A fluid pump **50**, which is connected via tube **52** to fluid inlet port **30**, supplies a coolant fluid **45**, which may be any coolant such as water, antifreeze or a dielectric coolant, to fluid distributing channel **28**. Tube **52** may be coupled to fluid inlet port **30** using a barbed fitting (not shown), for example, or by any other suitable means.

Fluid **45** passes into chamber **44** and through orifice **42**, which accelerates the fluid and causes it to impinge on second side **21** of substrate **18**. Alternatively, the fluid may impinge directly onto the underside of electronic component **10**, or onto the topside of component **10**, according to the orientation in which component **10** is mounted to substrate **18**. For example, if desired, a passage (not shown) may extend through substrate **18**, from first side **20** to a second side **21** of substrate **18**. The passage may be cylindrical, rectangular or of another suitable shape.

Orifice **42** is preferably configured such that the impingement point of the fluid is approximately aligned with the largest heat generating region or regions of component **10**. Fluid **45** may be discharged from orifice **42** at an angle to second side **21** of substrate **18**, preferably at a perpendicular angle to second side **21**, and may impact base **17** of component **10**, or may impact a thin member (not shown) between base **17** and carrier **19**, or a portion of carrier **19**. If a thin member separates electronic component **10** from carrier **19**, the surface of the thin member may be enhanced to increase heat transfer capabilities, using fins, a roughened surface, diamonds or a diamond-like carbon, for example.

Orifice **42** preferably exploits a hydrodynamic phenomenon known as the vena contracta, which occurs

-9-

when the ratio of the thickness of plate **40** and the width (or diameter) of orifice **42** is less than 0.9. When this condition is met, the effective flow area immediately downstream of the orifice is less than the actual area of orifice **42**. This reduced flow area causes the fluid to flow at a faster velocity than if the vena contracta was not present, and results in higher heat transfer coefficients in the impingement region.

The vena contracta phenomenon is illustrated in FIG. 6, where x **50** represents the width of orifice **42** and t **52** represents the thickness of plate **40**. It can be seen that flow area A **54** of fluid **45** is less than the area of orifice **42**.

Heated fluid enters chamber **46** and continues on through distributing channel **38** before exiting assembly **100** through fluid outlet port **31**. A portion of fluid **45** may remain for a period of time in recirculation region **47** of chamber **46**, and additional cooling benefits may be realized in region **47**, as well as in other portions of chamber **46**.

Excess fluid is removed from chamber **46** via fluid distributing channel **38**, where it exits assembly **100** via fluid outlet port **31**.

A heat exchanger **53**, connected to pump **50** by tube **54** and to fluid outlet port **48** by tube **56**, receives fluid from fluid outlet port **31**. Heat exchanger **53** rejects heat from the fluid, returning it to primarily a liquid phase. Fan **58** may be used to extend the cooling capacity of heat exchanger **53**. Cooled fluid is supplied from heat exchanger **53** to pump **50**. Thus, a closed-loop flow of coolant is formed. It will be appreciated that at any given point the coolant may be a vapor, a liquid or a vapor and liquid mixture.

It is contemplated that any conventional means for providing flow of a coolant may be used in conjunction

-10-

with the described embodiments of the present invention, and that more than one apparatus may be connected to a single source of coolant or that one or more sources of coolant may be connected to a single apparatus, for example, for redundancy purposes.

Sizes of fluid pump **50**, heat exchanger **53** and fan **58** should be selected based on heat removal and flow rate requirements. For example, a typical closed-loop fluid flow is 500 to 1000 milliliters per minute for 500 to 1000 Watts of heat dissipation. Pump and heat exchanger assemblies in various sizes, as well as acceptable tubing and fittings, are available from Cole-Parmer in Vernon Hills, Illinois, as well as other common sources.

An electronic component or a group of electronic components having a power density of up to 500 Watts per square centimeter is effectively cooled using the disclosed apparatus. The removal of heat directly from individual electronic components, rather than from an entire electronic module, helps to reduce operating temperatures of the components, increasing reliability through reduction of thermal variation and associated thermal stresses. In addition, efficient heat transfer at low flow rates may be realized.

Because fluid does not have to contact electronic components directly, the potential for contamination of the fluid is reduced. And fluid coolants may be used, for example, water and antifreeze may be used, which have very low toxicity and few handling problems.

The disclosed apparatus and method is thermally efficient, so that the operating temperature of the coolant fluid may reduce the size of a heat exchanger by fifty percent or more.

The apparatuses and methods described herein are also easily installed and removed. Thus, embodiments of the present invention are desirable for cooling an

-11-

electronic component during the testing and tuning process. For example, a test fixture may be designed to cool high heat-dissipating electronic components. But because the electronic component is mounted in a traditional fashion, the ease of assembly of the electronic component may be maintained.

The closed-loop fluid flow system described herein also has many advantages. For example, the system provides for unobstructed access to individual electronic components, further facilitating inspection, testing and repair of both the cooling system and the electronic components.

It should be appreciated that the present invention is not limited to cooling an electronic component, but may be adapted to cool any heat source, for example, a heat sink or flange which is mounted to a substrate in a traditional fashion.

It is further contemplated that wherever sealing and/or fastening may be required, numerous methods and materials may be used. For example, fasteners such as screws, compliant gaskets, ultrasonic welding, brazing, soldering or swaging may be utilized.

It will be apparent that other and further forms of the invention may be devised without departing from the spirit and scope of the appended claims and their equivalents, and it will be understood that this invention is not to be limited in any manner to the specific embodiments described above, but will only be governed by the following claims and their equivalents.

-12-

Claims

We claim:

1. An apparatus for cooling a heat source, the apparatus comprising:
 - a carrier plate having a channel therein, the channel having an inlet end and an outlet end;
 - a cooling region disposed in the carrier plate and in communication with the channel, the cooling region sized to be disposed proximate the heat source; and
 - a member disposed in the cooling region, the member having an orifice therein,wherein a ratio between a thickness of the member and a width of the orifice is less than 0.9.
2. The apparatus according to claim 1, wherein the member defines a first chamber and a second chamber within the cooling region,
 - the inlet end receiving a fluid and supplying the fluid to the first chamber via the channel, the orifice accelerating the fluid and discharging the fluid into the second chamber and toward the heat source.
3. The apparatus according to claim 2, wherein the fluid is selected from the group consisting of: water, antifreeze and a dielectric fluid.
4. The apparatus according to claim 1, wherein a shape of the orifice is any geometric shape.
5. The apparatus according to claim 1, wherein the heat source comprises an electronic component.
6. The apparatus according to claim 1, wherein the electronic component is one of a power transistor and an integrated circuit.

-13-

7. The apparatus according to claim 1, wherein the carrier plate is selected from the group consisting of: Aluminum Silicon Carbide (AlSiC), metal and plastic.

8. The apparatus according to claim 1, wherein the carrier plate comprises a first layer and a second layer.

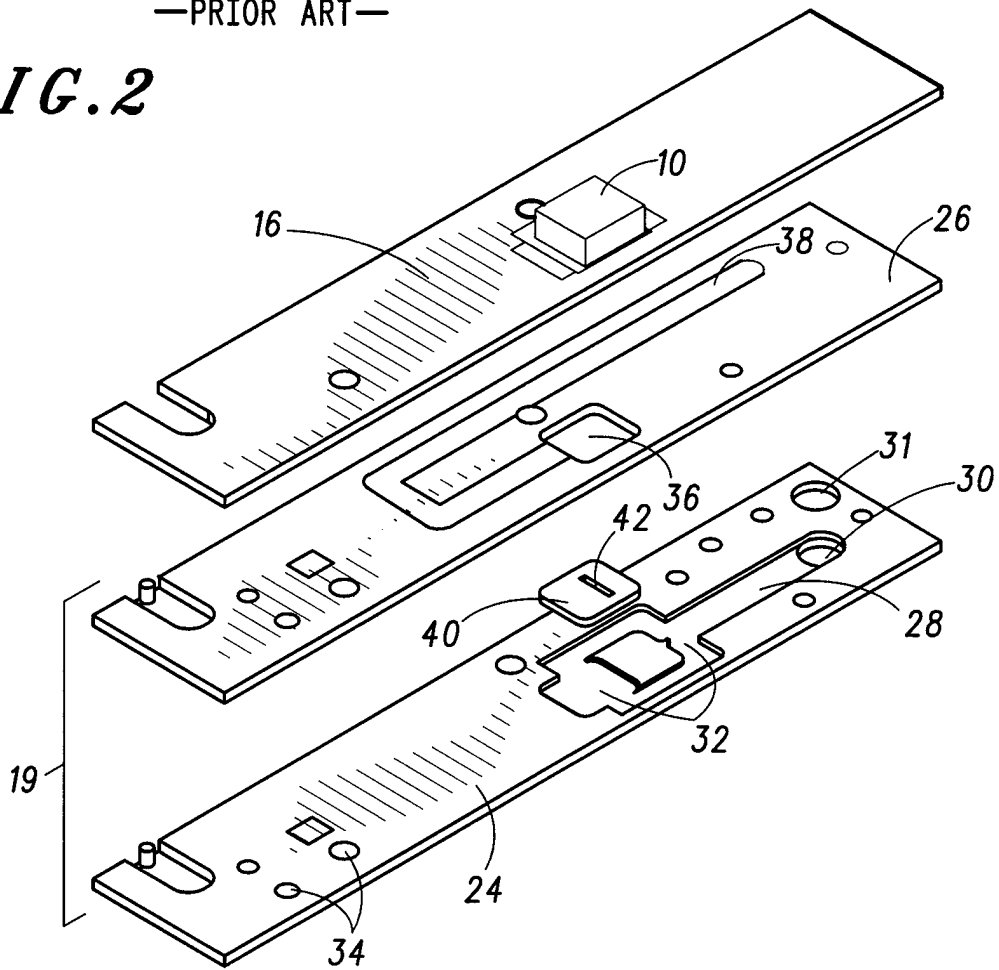
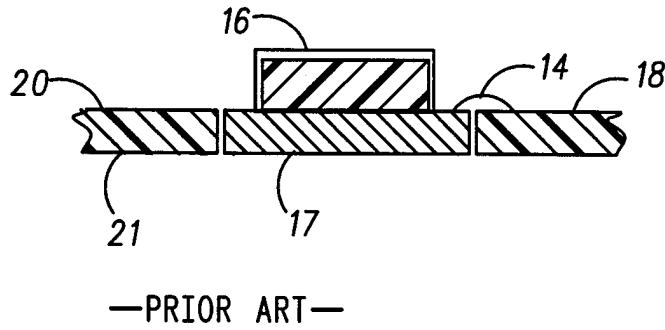
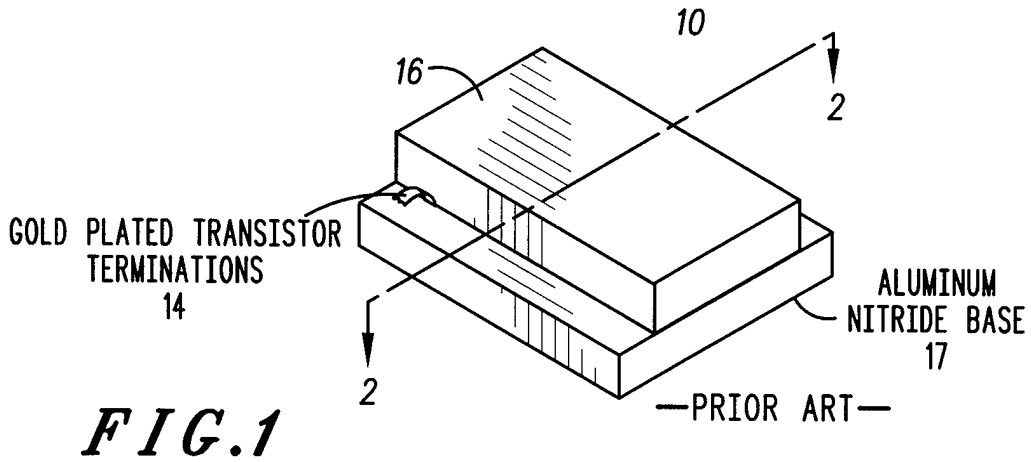

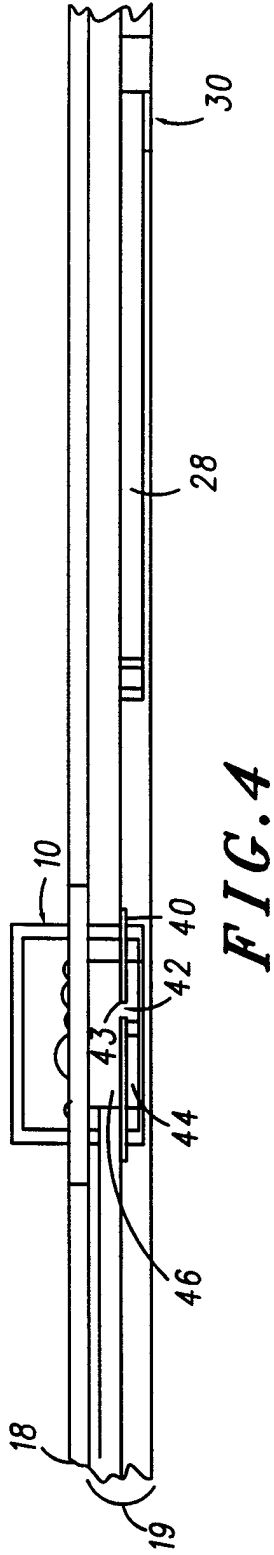

FIG. 4

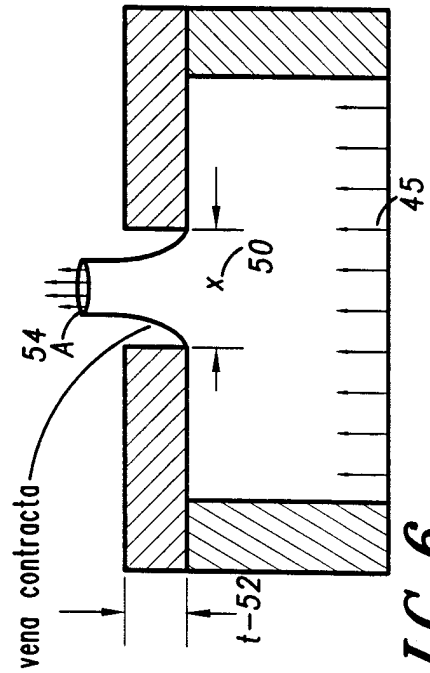
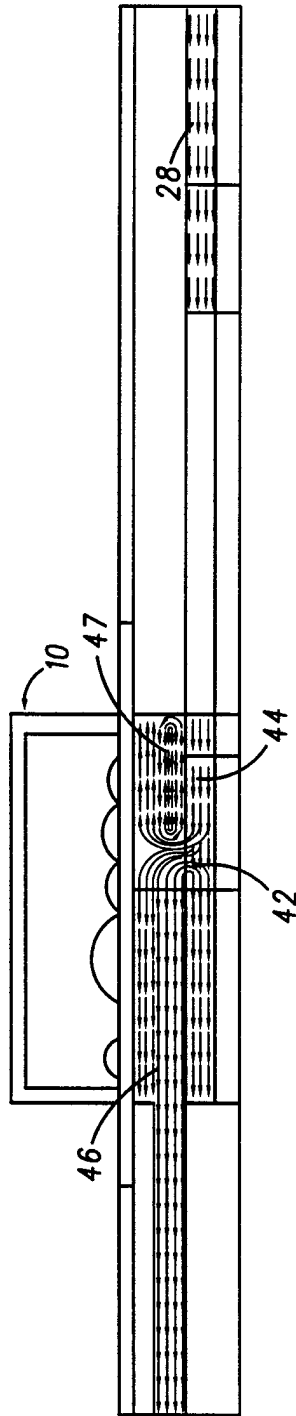
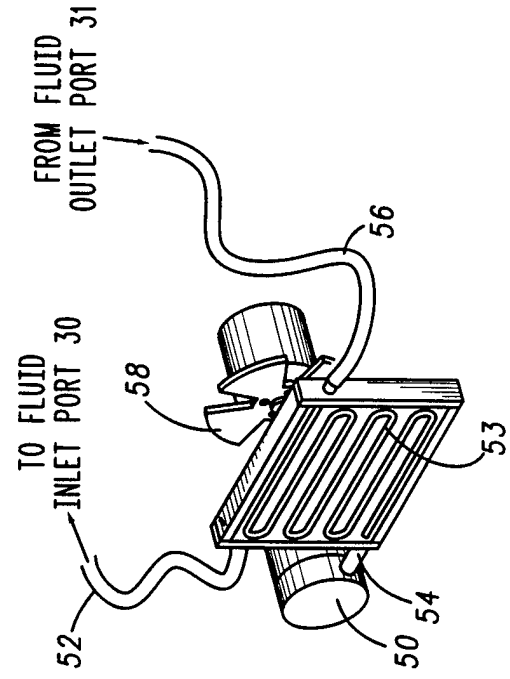

FIG. 5

FIG. 6



TO FLUID INLET PORT 30

FROM FLUID OUTLET PORT 31

INTERNATIONAL SEARCH REPORT

International application No.

PCT/US98/03648

A. CLASSIFICATION OF SUBJECT MATTER

IPC(6) :F28F 7/00; F28D 15/00; H01L 23/34; H05K 7/20

US CL :165/80.4, 104.33; 257/714; 361/699, 704, 710

According to International Patent Classification (IPC) or to both national classification and IPC

B. FIELDS SEARCHED

Minimum documentation searched (classification system followed by classification symbols)

U.S. : 165/80.4, 104.33; 257/714; 361/699, 704, 710

Documentation searched other than minimum documentation to the extent that such documents are included in the fields searched

Electronic data base consulted during the international search (name of data base and, where practicable, search terms used)

C. DOCUMENTS CONSIDERED TO BE RELEVANT

Category*	Citation of document, with indication, where appropriate, of the relevant passages	Relevant to claim No.
Y	US 5,316,075 A (QUON et al) 31 May 1994, SEE FIGURE 1.	1-8
A	US 5,263,536 A (HULBURD et al) 23 November 1993, SEE FIGURES 6, 7 and 9.	1-8
A	US 5,349,831 A (DAIKOKU et al) 27 September 1994, SEE FIGURE 1.	1-8
A	US 5,491,363 A (YOSHIKAWA) 13 February 1996, SEE FIGURE 4.	1-8

 Further documents are listed in the continuation of Box C.
 See patent family annex.

* Special categories of cited documents:	"T" later document published after the international filing date or priority date and not in conflict with the application but cited to understand the principle or theory underlying the invention
"A" document defining the general state of the art which is not considered to be of particular relevance	"X" document of particular relevance; the claimed invention cannot be considered novel or cannot be considered to involve an inventive step when the document is taken alone
"E" earlier document published on or after the international filing date	"Y" document of particular relevance; the claimed invention cannot be considered to involve an inventive step when the document is combined with one or more other such documents, such combination being obvious to a person skilled in the art
"I" document which may throw doubts on priority claim(s) or which is cited to establish the publication date of another citation or other special reason (as specified)	"&" document member of the same patent family
"O" document referring to an oral disclosure, use, exhibition or other means	
"P" document published prior to the international filing date but later than the priority date claimed	

Date of the actual completion of the international search

14 MAY 1998

Date of mailing of the international search report

30. 06. 1998

Name and mailing address of the ISA/US

Commissioner of Patents and Trademarks

Box PCT

Washington, D.C. 20231

Facsimile No. (703) 305-3230

Authorized officer

for CHRISTOPHER ATKINSON

Telephone No. (703) 308-2603