

(No Model.)

H. C. COWDREY.
HEATER.

No. 522,453.

Patented July 3, 1894.

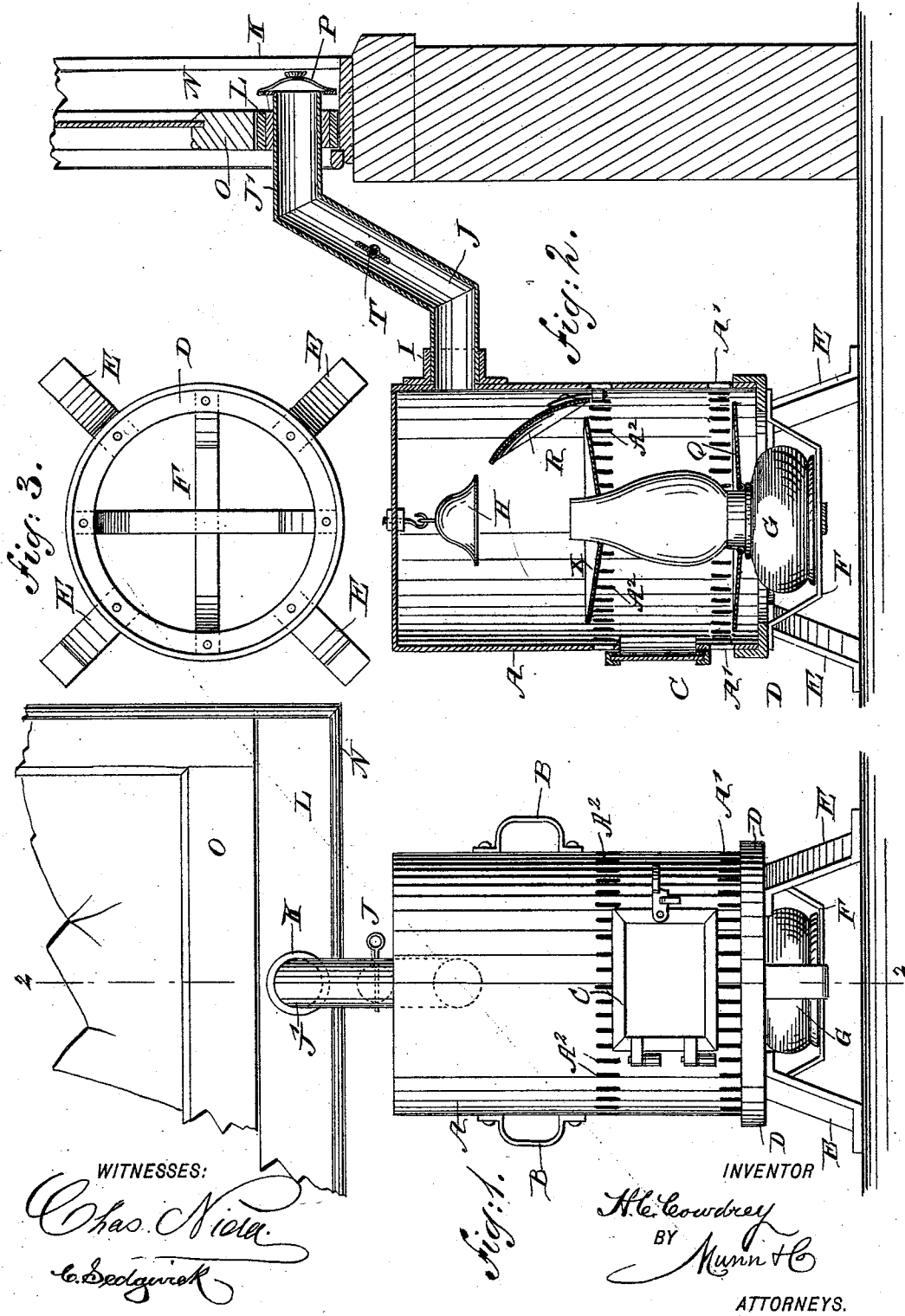

UNITED STATES PATENT OFFICE.

HARRIET CECIL COWDREY, OF NEW YORK, N. Y.

HEATER.

SPECIFICATION forming part of Letters Patent No. 522,453, dated July 3, 1894.

Application filed November 7, 1893. Serial No. 490,217. (No model.)

To all whom it may concern:

Be it known that I, HARRIET CECIL COWDREY, of the city, county, and State of New York, have invented a new and Improved Heater, of which the following is a full, clear, and exact description.

The object of the invention is to provide a new and improved heater, which is simple and durable in construction, and more especially designed for use in hall and other rooms, to conveniently heat the same by the employment of a lamp, and without any danger of vitiating the air in the room.

The invention consists of certain parts and details, and combinations of the same, as will be hereinafter described and then pointed out in the claims.

Reference is to be had to the accompanying drawings, forming a part of this specification, in which similar letters of reference indicate corresponding parts in all the figures.

Figure 1 is a front elevation of the improvement. Fig. 2 is a transverse section of the same on the line 2—2 of Fig. 1; and Fig. 3 is a plan view of the ring with its legs and basket.

The improved heater is provided with a shell A, preferably made of sheet metal and cylindrical in form, with the top closed and the bottom open, and the lower end provided with slits A' as plainly illustrated in Figs. 1 and 2. On the sides of the shell A are arranged suitable handles B, for conveniently carrying the shell for the purpose hereinafter more fully described.

On the front of the shell A and near the lower end thereof but above the slits A', is arranged a door C, preferably having a panel of thick mica, to view the light of the burning lamp without disclosing the outlines of the lamp used in the shell. The lower end of the shell A is set in the ring D, either formed in the top with a groove or made with an upwardly-turned flange, as illustrated in Fig. 2, so as to securely hold the lower end of the shell in place.

The ring D is provided with legs E, adapted to rest on the floor of the room and serving to hold the ring D and the shell A, a suitable distance above the floor. The ring D also supports a depending basket F, preferably made of a number of cross bars attached at

their upper ends to the under side of the ring and bent downwardly to form an open basket, for supporting the lamp G, of any approved construction, and at the same time affording an entrance for the air to the interior of the shell A. From the top of the shell A depends a smoke bell H, arranged directly over the chimney of the lamp G, as plainly shown in Fig. 2.

Near the upper end of the shell A and at the rear thereof is arranged a collar I, surrounding the opening in the shell and in this collar extends the lower end of a pipe J, for carrying off the smoke, gases, odors, &c., arising from the burning of the lamp G within the shell A. This pipe J may be connected with a chimney in case the room in which the heater is used is provided with a chimney, but as the heater is more especially intended for use in hall rooms having no chimneys, I prefer to pass the upper horizontal part J' of the pipe J through a collar K, made of asbestos, porcelain or other refractory material, the said collar being fitted into an opening formed in a bar L, made of wood and fitted into the guideway and resting on the sill of a window frame N, as plainly illustrated in Figs. 1 and 2.

In order to place the bar L in position, the lower sash O is raised a short distance to permit the insertion of the bar in the guideway of the casing, after which the sash O is lowered to rest with its lower cross bar, on top of the bar L. On the extreme outer end of the horizontal part J' of the pipe J is arranged an ornamental hood P to prevent the wind from blowing into the pipe J. The pipe end in the bar L is preferably made oblong to reduce the height of the bar L without however, reducing the exhausting capacity of the pipe.

In order to shield the front of the lamp G from the heat in the shell A, I provide an imperforate shield Q preferably made dish-like and of asbestos or other suitable material. This shield is set directly on the neck of the lamp and its outer edge terminates a suitable distance from the inner surface of the shell about in alignment with the lower ends of the slits A' to permit free circulation of air up into the shell A. Near the top of the lamp chimney S, I provide a similar shield X, and approximately in the plane of this shield the

shell A is provided with a second row of slits A². The shields Q and X fit tightly around the neck of the lamp and the chimney respectively, as will be seen in Fig. 2.

5 In order to retain the heated air as long as possible in the shell A to radiate the heat from the latter into the room, I provide a deflector R secured inside of the shell preferably below the opening leading to the pipe J
10 as illustrated in Fig. 2. This deflector tends to throw the rising air forward and downward to cause it to travel up on the front of the shell and along the top thereof in order to reach the opening to pipe J. In the latter is
15 preferably arranged a damper T to regulate the exit of the heated air, smoke, gases, &c.

The heater is used as follows: The shell A is taken hold of by the operator engaging the handles B to remove the shell from the ring
20 D, after which the lighted lamp G is set in the basket F and then the shell A is set on the ring D and connection is made between the pipe J and collar K. The flame of the lamp G is now dimly visible through the mica
25 of the door C, so as to give the heater the appearance of having a coal or other fire within the shell A. If necessary the door C can be opened to permit of attending to the wick raising device, so as to enlarge the flame or
30 decrease the same, or completely extinguish it, as the case may require. Now, it will be seen that the heat emanating from the burning of the lamp G, heats the surrounding air so that the shell A is heated, and the heat radiates therefrom to heat the room. Air necessary for combustion of the lamp G and for
35 circulation in the shell can pass to the shell A through the open basket F and slits A', and part of the air entering through the said slits
40 and heated as it travels upward along the chimney S issues into the room through the slits A², being checked and deflected by the upper shield, while a portion of the heated air, smoke, gases, odors, &c., arising in the

shell A are readily carried off through the
45 pipe J leading either to the chimney or through the window as above described. Thus the burning of the lamp will not cause any smoke, gases or odors in the room, but will serve to heat the same in a very complete and thor-
50 oughly economical manner.

The hood P prevents back draft in the pipe J, and the collar K prevents burning of the bar L set in the window frame N.

Having thus fully described my invention,
55 I claim as new and desire to secure by Letters Patent—

1. A heater provided with a flanged ring, a lamp, supporting basket secured to and depending from the said ring, legs extending
60 downwardly from the ring to support it on the floor, and a shell whose lower edge rests on the said ring, the said shell being provided near its lower end, with a row of openings for
65 the ingress of air, the shell being also provided, at a distance from the first row of openings approximately corresponding to the length of the lamp chimney to be used, with another row of openings for the egress of air,
70 substantially as described.

2. In a heater, the combination with a lamp and a shell having a series of openings, of a shield fitting tightly around the lamp and located in the shell approximately in line with
75 the lower ends of the openings and intermediate of the lamp burner and the fount, substantially as described.

3. The combination with a lamp and the shell having a series of openings near the top of the lamp chimney, of a shield fitting tightly
80 around the chimney near the top thereof, and arranged essentially in alignment with the said openings, substantially as described.

HARRIET CECIL COWDREY.

Witnesses:

THEO. G. HOSTER,
C. SEDGWICK.