

(19) World Intellectual Property Organization
International Bureau



(43) International Publication Date
8 November 2007 (08.11.2007)

PCT

(10) International Publication Number
WO 2007/124610 A1

(51) International Patent Classification:
C07K 16/28 (2006.01) *A61P 39/00* (2006.01)
A61K 39/00 (2006.01)

(21) International Application Number:
PCT/CH2007/000202

(22) International Filing Date: 27 April 2007 (27.04.2007)

(25) Filing Language: English

(26) Publication Language: English

(30) Priority Data:
60/795,831 28 April 2006 (28.04.2006) US

(71) Applicant (for all designated States except US): **ESBAT-ECH AG** [CH/CH]; Wagistrasse 21, CH-8952 Schlieren (CH).

(72) Inventors; and

(75) Inventors/Applicants (for US only): **AUF DER MAUR, Adrian** [CH/CH]; Herbstweg 110, CH-8050 Zürich (CH). **LICHTLEN, Peter** [CH/CH]; Soodrain 3, CH-8134 Adliswil (CH). **BARBERIS, Alcide** [CH/CH]; Allensmoosstrasse 64, CH-8057 Zürich (CH).

(74) Agent: **E. BLUM & CO. AG**; Vorderberg 11, CH-8044 Zürich (CH).

(81) Designated States (unless otherwise indicated, for every kind of national protection available): AE, AG, AL, AM,

AT, AU, AZ, BA, BB, BG, BH, BR, BW, BY, BZ, CA, CH, CN, CO, CR, CU, CZ, DE, DK, DM, DZ, EC, EE, EG, ES, FI, GB, GD, GE, GH, GM, GT, HN, HR, HU, ID, IL, IN, IS, JP, KE, KG, KM, KN, KP, KR, KZ, LA, LC, LK, LR, LS, LT, LU, LY, MA, MD, MG, MK, MN, MW, MX, MY, MZ, NA, NG, NI, NO, NZ, OM, PG, PH, PL, PT, RO, RS, RU, SC, SD, SE, SG, SK, SL, SM, SV, SY, TJ, TM, TN, TR, TT, TZ, UA, UG, US, UZ, VC, VN, ZA, ZM, ZW.

(84) Designated States (unless otherwise indicated, for every kind of regional protection available): ARIPO (BW, GH, GM, KE, LS, MW, MZ, NA, SD, SL, SZ, TZ, UG, ZM, ZW), Eurasian (AM, AZ, BY, KG, KZ, MD, RU, TJ, TM), European (AT, BE, BG, CH, CY, CZ, DE, DK, EE, ES, FI, FR, GB, GR, HU, IE, IS, IT, LT, LU, LV, MC, MT, NL, PL, PT, RO, SE, SI, SK, TR), OAPI (BF, BJ, CF, CG, CI, CM, GA, GN, GQ, GW, ML, MR, NE, SN, TD, TG).

Published:

- with international search report
- before the expiration of the time limit for amending the claims and to be republished in the event of receipt of amendments
- with sequence listing part of description published separately in electronic form and available upon request from the International Bureau

For two-letter codes and other abbreviations, refer to the "Guidance Notes on Codes and Abbreviations" appearing at the beginning of each regular issue of the PCT Gazette.



WO 2007/124610 A1

(54) Title: ANTIBODIES BINDING TO THE EXTRACELLULAR DOMAIN OF THE RECEPTOR TYROSINE KINASE ALK

(57) Abstract: The present invention concerns an antibody specific for human ALK (Anaplastic Lymphoma Kinase), in particular a scFv, a nucleic acid sequence encoding it, its production and its use as a pharmaceutical or for diagnostic purposes. Said antibody is suitable for the local treatment of tumors, in particular glioblastoma.

Antibodies binding to the extracellular domain of the Receptor Tyrosine Kinase ALK

Related Information

The application claims priority to U.S. provisional patent application number 60/795,831, filed on April 28, 2006, the entire contents of which are hereby incorporated by reference.

The contents of any patents, patent applications, and references cited throughout this specification are hereby incorporated by reference in their entireties.

Technical Field

The present invention concerns an antibody specific for human ALK (Anaplastic Lymphoma Kinase), in particular a scFv, a nucleic acid sequence encoding it, its production and its use as a pharmaceutical or for diagnostic purposes. Said antibody is suitable for the local treatment of tumors or cancer, in particular glioblastoma.

Background Art

ALK (Anaplastic Lymphoma Kinase; CD246) is a member of the receptor tyrosine kinase (RTK) family. As a typical member of this family, it is a type-I transmembrane protein essentially consisting of three domains: the extracellular ligand-binding domain (aa19-1038), which contains one LDL-receptor class A domain and two MAM domains (MAM: Meprin, A5 antigen, protein tyrosine phosphatase μ), a transmembrane domain (aa1039-1059) and a cytoplasmic domain (aa 1060-1620), containing the tyrosine kinase domain. A signal peptide is present at the N-

terminus of the nascent protein (aa 1-18), which is cleaved upon secretion.

The full-length human and mouse ALK were cloned in 1997 by two independent groups (Iwahara 1997; Morris 1997). ALK is highly similar to the RTK called Leukocyte Tyrosine Kinase (LTK) and belongs to the insulin receptor superfamily. ALK exhibits 57% aa identity and 71% aa similarity with LTK in their regions of overlap (Morris 2001). ALK is highly N-glycosylated and contains 21 putative N-glycosylation sites. Amino acids 687 to 1034 have significant similarity (50% aa identity) to LTK. However, the N-terminus proximal 686 aa sequence shows no homology to any known proteins with the exception of a very short sequence also found in the LDL receptor (Duyster 2001/SWISSPROT). In addition, it contains two MAM domains at aa264-427 and aa478-636 (Meprin, A5 antigen, protein tyrosine phosphatase μ). These domains are thought to have an adhesive function, as they are widespread among various adhesive proteins implicated in cell-to-cell interaction (De Juan 2002). Furthermore, there is a binding site for the ALK putative ligands corresponding to amino acids 396-406 (Stoica 2001; see below). The amino acid sequence of the kinase domain of murine ALK shows 98% aa-identity to human ALK, 78% identity to mouse LTK, 52% to mouse ros, 47% to human insulin-like growth factor receptor and 46% to human insulin receptor (Iwahara 1997; Ladanyi 2000). No splice variants of ALK have been described to date. However, ALK is often associated with chromosomal translocations (see below).

The ALK gene spans about 315kb and has 26 exons. Much of the gene consists of two large introns that span about 170kb. The ALK transcript is 6.5kb of length

(Kutok 2002). According to Morris, the cDNA spans 6226bp (Morris 2001).

ALK expression in mice starts during embryogenesis around the development stage E11 and is persisting in the neonatal periods of development where it is expressed in the nervous system. In the adult, its physiological expression is restricted to certain neuronal (neural and glial cells and probably endothelial cells) regions of the CNS at low levels (Morris 1997; Duyster 2001; Stoica 2001). Actually, the abundance of ALK decreases in the postnatal period (Morris 2001). Based on its expression pattern, a role for the receptor in brain development is suggested (Duyster 2001). The neural-restricted expression of ALK suggests that it serves as a receptor for neurotrophic factors (see later). Consistent with this, its expression pattern overlaps with the genes encoding the TRK family of neurotrophin receptors (Morris 2001). However, ALK knockout mice do not show any obvious phenotype (unpublished data), which might be due to some functional redundancy with TRK family members or other neurotrophin receptors. Notably, hematopoietic tissues show no detectable expression of ALK (see later) (Morris 2001).

Two potential ligands for ALK have recently been described, "pleiotrophin" (PTN) and "midkine" (MK) (Stoica 2001; Duyster 2001; Stoica 2002). The PTN-ALK interaction was identified by using purified human pleiotrophin protein to screen a phage display peptide library. By this method, a sequence of ALK present in its extracellular domain (aa 396-406) was identified. Importantly, this sequence is not shared with LTK, the RTK most closely related to ALK. This ligand-binding region is also conserved in the potential homologue of ALK in

Drosophila (Loren 2001). ALK is phosphorylated rapidly upon PTN binding (Bowden 2002). Moreover, ALK has been shown to be stimulated by pleiotrophin in cell culture. This makes the pleiotrophin/ALK interaction particularly interesting in the light of the pathological implications pleiotrophin has (Stoica 2001). Cell lines that lack ALK expression also fail to show a growth response to pleiotrophin and vice versa (Stoica 2001). In vivo, elevated pleiotrophin levels in the serum of patients suffering from various solid tumors have been demonstrated, and animal studies have suggested a contribution of pleiotrophin to tumor growth (Stoica 2001). The role of PTN as rate-limiting angiogenic factor in tumor growth is well established in animal models (Choudhuri 1997). In 1996 Czubyko et al. (Czubyko 1996) demonstrated the importance of PTN in tumor angiogenesis, in prevention of apoptosis and metastasis by modulating PTN levels with a ribozyme targeting approach. Serum level measurements of PTN in mice demonstrated a clear correlation with the size of the tumor. PTN plays a significant role in some of the most aggressive human cancer types such as melanoma and pancreatic cancer thus giving interesting perspectives for potential further applications of an ALK inhibitor (Weber 2000; Stoica 2001). In human patients, elevated serum pleiotrophin levels were found in patients with pancreatic cancer ($n = 41$; $P < .0001$) and colon cancer ($n = 65$; $P = .0079$). In healthy individuals, PTN is expressed in a tightly regulated manner during perinatal organ development and in selective populations of neurons and glia in the adult.

Co-expression of PTN and ALK, as found in several cancer cell lines, indicates that they could form an autocrine loop of growth stimulation (Stoica 2001). In

spite of all these data, literature tells that is not yet clear if the effects of PTN are mediated by ALK alone and/or by other unidentified PTN receptors (Duyster 2001). At least two other potential receptors of PTN have been suggested: the receptor tyrosine phosphatase RPTP β and the heparan sulfate proteoglycan N-syndecan. However, RPTP β might act as a signalling modulator of PTN/ALK signalling and N-syndecan as a chaperone for the ligand. (Bowden 2002).

Recently, another secreted growth factor related to pleiotrophin called midkine (MK) has been identified as a second ligand for ALK. Similarly to PTN, binding and activating functions (e.g. induction of soft agar colony formation in cell cultures) of MK can be blocked by the same antibody raised against the ALK-ECD (Stoica 2001). Like pleiotrophin, midkine is upregulated in many tumors, although its physiological expression is very restricted in adult normal tissues (Stoica 2002). Analysis of 47 bladder tumor samples revealed that MK expression is significantly (about four times) enhanced as compared to normal bladder tissue. Furthermore, pronounced overexpression correlates with poor patient survival (O'Brien 1996).

However, the affinity of MK for ALK is about 5 times lower than the one of pleiotrophin (Stoica 2002). Interestingly, as with pleiotrophin, inhibition of ALK via ribozymes also inhibits the effects of MK in cell culture (Stoica 2002). The authors of these studies also come to the conclusion that inhibition of the PTK/MK/ALK pathway opens very attractive possibilities for the treatment of various diseases, some of them having very limited treatment options so far, such as, for example, glioblastoma and pancreatic cancer. (Stoica 2002).

In healthy individuals, ALK mRNA expression peaks during the neonatal period and persists in adults in a few selected portions of the nervous system. Recently, expression of the ALK protein was also detected in endothelial cells that were associated to neuronal and glial cells. Evidence that at least a part of the malignant activities described for pleiotrophin are mediated through ALK came from experiments in which the expression of ALK was depleted by a ribozyme targeting approach. Such depletion of ALK prevented pleiotrophin-stimulated phosphorylation of the anti-apoptotic protein Akt and led to a prolonged survival of mice that had received xenografts. Indeed, the number of apoptotic cells in the tumor grafts was significantly increased, when ALK expression was depleted (Powers 2002).

Evidence that malignant activities described for MK are mediated through ALK came from experiments with monoclonal antibodies directed against the ALK ECD. Addition of a 1:25 dilution of hybridoma cell supernatant from two anti-ALK ECD antibodies leads to a significant decrease in colony formation of SW-13 cells in soft agar (Stoica 2002). Analysis of ten different cell lines revealed that the ability for a growth response to PTN perfectly correlated with the expression of ALK mRNA (the following cell lines responded to PTN and were found to express ALK mRNA: HUVEC, NIH3T3, SW-13, Colo357, ME-180, U87, MD-MB 231; Stoica 2001). Interestingly, in some cancer cell lines (Colo357 pancreatic cancer, Hs578T breast cancer and U87 glioblastoma), PTN and ALK are co-expressed, indicating that PTN and ALK form an autocrine loop of growth stimulation (Stoica 2001).

Interestingly, both PTN and MK have been shown to cause transcriptional up-regulation of the anti-

apoptotic bcl-2 protein (Stoica 2002). In addition activated Akt (which is a crucial downstream target of aberrant ALK signalling) phosphorylates the pro-apoptotic factor called bad, thus leading to dissociation from bcl-xl, which, when liberated from bad, can suppress apoptosis by blocking the release of cytochrome c (see Bowden 2002 for references).

Aberrant expression of ALK might be involved in the development of several cancers. However, it was first associated with a subgroup of high-malignant Non-Hodgkin lymphomas (NHLs), the so-called Anaplastic Large Cell Lymphomas (ALCLs). Non-Hodgkin lymphomas represent clonal neoplasias originating from various cells of lymphatic origin.

Most patients with the primary systemic clinical subtype of ALCL have the t2,5 translocation, expressing a fusion protein that joins the N-terminus of nucleophosmin (NPM) to the C-terminus of ALK. The fusion consists of aa 1-117 of NPM fused to aa 1058-1620 of ALK and the chromosomal breakage is located in an intron located between the exons encoding the TM and juxtamembrane domain of ALK (Duyster 2001). NPM-ALK is a transcript containing an ORF of 2040bp encoding a 680aa protein (Morris 2001). This corresponds to a breakage in intron 4 of NPM, which spans 911 bp and intron 16 of ALK which spans 2094bp (Kutok 2002). Most likely the ALK sequence in this fusion protein is the minimal sequence required for the protein to lead to ALCL (Duyster 2001). The inverse fusion (ALK-NPM) is not expressed, at least not in lymphoid cells (Kutok 2002). The wild-type NPM protein demonstrates ubiquitous expression and functions as a carrier of proteins from the cytoplasm into the nucleus. As a matter of fact, NPM is a 38kDa nuclear protein

encoded on chromosome 5 that contains a NLS, binds nuclear proteins and engages in cytoplasm/nuclear trafficking (Duyster 2001). NPM is one of the most abundant nucleolar proteins and is normally present as a hexamer (Morris 2001). Most importantly NPM normally undergoes self-oligomerization (hexamers) as well as hetero-oligomerization with NPM-ALK (Duyster 2001). The 2;5 translocation brings the ALK gene portion encoding the tyrosine kinase on chromosome 2 under the control of the strong NPM promoter on chromosome 5, producing permanent expression of the chimeric NPM-ALK protein (p80) (Duyster 2001). Hence, ALK kinase is deregulated and ectopic, both in terms of cell type (lymphoid) and cellular compartment (nucleus/nucleolus and cytoplasm) (Ladanyi 2000). The localization (cytoplasm or nucleus) of NPM seems not to affect its effect on lymphomagenesis (Duyster 2001). The resultant aberrant tyrosine kinase activity triggers malignant transformation via constitutive phosphorylation of intracellular targets. Various other less common ALK fusion proteins are associated with ALCL. All variants demonstrate linkage of the ALK tyrosine kinase domain to an alternative promoter that regulates its expression.

Full-length ALK has been reported to be also expressed in about 92% of primary neuroblastoma cells and in some rhabdomyosarcomas (Lamant 2000). However, no correlation between ALK expression and tumor biology has been demonstrated so far. This fact, taken together with the lack of evidence regarding significant levels of endogenously phosphorylated ALK in these tumors, suggest that ALK expression in neuroblastoma reflects its normal expression in immature neural cells rather than a primary oncogenic role and ALK in these tumors is not constitutively phosphorylated thus questioning an important role

for ALK in these tumors (Duyster 2001; Pulford 2001). Nevertheless, ALK signalling might be important in at least some neuroblastomas, as suggested by Miyake et al., who found overexpression and constitutive phosphorylation of ALK due to gene amplification in neuroblastoma-derived cell lines (Miyake 2002). However, other neuroblastoma-derived cell lines do not show constitutive activation of ALK, thus arguing against a general pathological involvement of ALK (Dirks 2002; Pulford 2004).

Most interestingly, ALK seems to be important for growth of glioblastoma multiforme, a highly malignant brain tumor that offers very limited therapeutic options (Powers 2002). Multiple genetic alterations have been shown to occur in these devastating tumors including loss or mutations of PTEN, p53 and INK4a-ARF. In addition, RTK signalling plays a particularly important role in growth and development of these tumors, which overexpress various growth factors such as PDGF, HGF, NGF and VEGF suggesting autocrine RTK signalling loops. Powers and colleagues have shown mRNA and protein expression of ALK in glioblastoma patient tumor samples, whereas the signals were not detectable in normal adjacent brain tissue (Powers 2002). Furthermore, human U87MG glioblastoma cells (which are derived from a patient and represent a well-characterized model system to study tumorigenesis and signalling in glioblastoma) show ALK-dependent anti-apoptotic behaviour in xenograft studies. When ALK is depleted in these tumor cells by the use of ribozymes, mice injected with these tumor cells survive at least twice as long as when injected with wild-type tumor cells, and these tumor cells show drastically increased apoptosis. Thus, ALK and its ligand(s) provide an essential survival signal that is rate-limiting for tumor growth of U87MG

cells in vivo (Powers 2002). These findings indicate that inhibition of ALK signalling could be a promising approach to improve life expectancy of glioblastoma patients.

Glioblastoma multiforme is by far the most common and malignant primary glial tumor with an incidence of about 2/100'000/y (about 15'000 cases in US and Western Europe per year). It affects preferentially the cerebral hemispheres, but can also affect the brain stem (mainly in children) or the spinal cord. The tumors may manifest de novo (primary glioblastoma) or may develop from lower grade astrocytomas (secondary glioblastoma). Primary and secondary glioblastomas show little molecular overlap and constitute different disease entities on molecular level. They both contain many genetic abnormalities including affection of p53, EGFR, MDM2, PDGF, PTEN, p16, RB.

No significant therapy advancement has occurred in the last 25 years. Therapies are only palliative and can expand the life expectancy from 3 months to 1 year. Patients usually present with slowly progressive neurological deficit, e.g. motor weakness, intracranial pressure symptoms, e.g. headache, nausea, vomiting, cognitive impairment, or seizures. Changes in personality can also be early signs. The etiology of glioblastoma is unknown, familial cases represent less than 1%. The only consistent risk factor identified is exposure to petrochemicals. Diagnosis is made mainly by imaging studies (CT, NMR) and biopsy. Completely staging most glioblastomas is neither practical nor possible because these tumors do not have clearly defined margins. Rather they exhibit well-known tendencies to invade locally and spread along compact white matter pathways. The primary reason

why no curative treatment is possible is because the tumor is beyond the reach of local control when diagnosed. The primary chemotherapeutic agents are carmustine (an alkylating agent) and cisplatinum but only 40% of patients show some response.

Although there are quite some uncertainties regarding the role of ALK in glioblastoma, this disease offers various approaches for ALK-directed drugs. In fact, for this devastating disease even a small improvement of current therapy options would serve an enormous medical need. It is important to note that since glioblastoma cells express the full-length ALK, for treating this cancer ALK could be considered as a target not only for small molecule kinase inhibitors but also for antibodies and/or antibody fragments such as scFvs, i.e. to induce apoptosis of tumor cells. The strict localization of glioblastoma to the CNS supports the use of scFvs, if they can be delivered efficiently to the CNS (no rapid clearance due to compartmentalization, but better tumor penetration compared to IgGs due to their smaller size). Antibodies and/or antibody fragments could be directed against the ligand-binding sequence of ALK (aa 396-406) or against other parts of the extracellular parts of the receptor.

The very limited expression of ALK in healthy tissues under physiological conditions indicates that tumors expressing ALK might be an excellent target for disease treatment using radioactive or toxin-labelled antibodies and/or antibody fragments, irrespective of whether ALK is involved in the pathogenesis of these tumors or not. In addition to glioblastoma cells, ALK expression has been found with high significance in melanoma cell lines and breast carcinoma cell lines (without being con-

stitutively phosphorylated) (Dirks 2002). The fact that a large portion of the extracellular domain of ALK seems to be rather unique in the human proteome should make this approach highly specific.

WO9515331/US5529925 discloses the cloning and sequencing of the human nucleic acid sequences, which are rearranged in the t(2;5)(p23;q35) chromosomal translocation event which occurs in human t(2;5) lymphoma. The rearrangement was found to bring sequences from the nucleolar phosphoprotein gene (the NPM gene) on chromosome 5q35 to those from a previously unidentified protein tyrosine kinase gene (hereinafter the ALK gene) on chromosome 2p23. The sequence of the fusion gene and fusion protein (NPM/ALK fusion gene or protein, respectively) were also disclosed.

The full-length ALK sequence is patented in US5770421, entitled "Human ALK Protein Tyrosine Kinase."

Furthermore, the patent US6174674B1 entitled "Method of detecting a chromosomal rearrangement involving a breakpoint in the ALK or NPM gene", discloses primers for detecting the NPM-ALK fusion sequence in patient samples. In another patent application, US6696548 entitled "ALK protein tyrosine kinase/receptor and ligands thereof", the use of ALK for detection of ALK ligands and antibodies binding to specific sequences of ALK is disclosed. It also discloses a method of identifying an agent capable of binding to the isolated ALK polypeptide.

WO0196394/US20020034768 discloses ALK as receptor of pleiotrophin. US20040234519 discloses anti-pleiotrophin antibodies, and WO2006020684 describes the detection of pleiotrophin.

Disclosure of the Invention

Hence, it is a general object of the invention to provide a stable and soluble antibody or antibody derivative, which binds the human ALK protein *in vitro* and *in vivo*. Most preferably, the antibody is specifically targeted against the ligand-binding domain of ALK (amino acids 396-406) and hence will block both the biologic effects of MK, which has a Kd for ALK of about 170 pM, as well as the biologic effects of PTN, which has a Kd for ALK of about 20 -30 pM (Stoica 2002; Stoica 2001). In a preferred embodiment said antibody or antibody fragment is a scFv antibody or a Fab fragment. In the following the term antibody comprises full-length antibodies as well as other antibody derivatives.

Now, in order to implement these and still further objects of the invention, which will become more readily apparent as the description proceeds, said antibody is manifested by the features that it comprises a variable heavy chain CDR3 of a sequence of at least 50% identity to the sequence SEQ. ID. No. 2. Preferably, the sequence identity is at least 60%, 65%, 75%, 85%, or more preferably at least 92%. Most preferably, said antibody has a VH CDR3 of the sequence SEQ. ID. No.2.

In one embodiment, the antibody or antigen binding portion thereof of the invention specifically binds to a particular epitope of the ALK protein. Such epitopes reside, for example, within amino acids 1-50, 50-100, 100-150, 150-200, 200-250, 250-300, 300-350, 350-400, 400-450, 450-500, 500-550, 550-600, 600-650, 650-700, 700-750, 750-800, 800-900, 900-1000, 1000-1100, 1100-1200, 1200-1300, 1300-1400, 1400-1500, or 1500-1620 of the ALK protein, or any interval, portion or range thereof. In one embodiment, the antibody or antigen binding portion thereof specifically binds to an epitope

comprising, essentially consisting of or a fragment of the region spanning amino acid residues 391 ± 3 and 406 ± 3 (SEQ. ID No: 91 shows amino acid residues 388 to 409 of the human ALK protein), preferably amino acids 391-406 (SEQ. ID.No: 1) of the ALK protein (SEQ ID NO: 1). It is understood that the indicated range is not to be considered as having sharp boundaries, but that the antibody or antigen binding portion thereof may bind or partially bind in a region closely situated to or within the ligand-binding domain of ALK. Preferably, the antibodies or antibody-derivatives bind to an epitope of the ALK protein of 10 to 20 amino acids in length.

In another embodiment the antibody or antigen binding portion thereof can be characterized as specifically binding to an ALK protein with a K_D of less than about 10×10^{-6} M. In a particular embodiment, the antibody or antigen binding portion thereof specifically binds to an ALK protein (or fragment thereof) with a K_D of at least about 10×10^{-7} M, at least about 10×10^{-8} M, at least about 10×10^{-9} M, at least about 10×10^{-10} M, at least about 10×10^{-11} M, or at least about 10×10^{-12} M or a K_D even more favorable.

In various other embodiments, the antibody or antigen binding portion thereof includes a variable heavy chain region comprising an amino acid sequence at least 80%, 85%, 90%, 95%, 98%, or more preferably at least 99% identical to a variable heavy chain region amino acid sequence as set forth in SEQ ID NO: 4.

In other embodiments, the antibody or antigen binding portion thereof includes a variable light chain region comprising an amino acid sequence at least 80%, 85%, 90%, 95%, 98% or more preferably at least 99% iden-

tical to a variable light chain region amino acid sequence as set forth in SEQ ID NO: 5.

In still other embodiments, the antibody or antigen binding portion thereof includes both a variable heavy chain region comprising an amino acid sequence at least 80%, 85%, 90%, 95%, 98% or more preferably at least 99% identical to a variable heavy chain region amino acid sequence as set forth in SEQ ID NO: 4 and a variable light chain region comprising an amino acid sequence at least 80%, 85%, 90%, 95%, 98% or more preferably at least 99% identical to a variable light chain amino acid sequence as set forth in SEQ ID NO: 5.

In certain other embodiments, the antibody or antigen binding portion thereof specifically bind to an epitope that overlaps with an epitope bound by an antibody or antibody derivative of ESBA521 (Seq. ID. No. 19) and/or competes for binding to an ALK protein, or portion thereof, with an antibody or antibody derivative of ESBA521. In a related embodiment, the antibody or antigen binding portion thereof specifically binds to an epitope comprising residues 391-406 (SEQ ID NO: 1) of an ALK protein, or portion thereof.

The variable heavy and light chain regions of the antibodies or antigen binding portions thereof typically include one or more complementarity determining regions (CDRs). These include the CDR1, CDR2, and CDR3 regions. In particular embodiments, the variable heavy chain CDRs are at least 80%, 85%, 90%, 95%, or more preferably 100% identical to a CDR of the ESBA521 antibody. In other particular embodiments, variable light chain CDRs are at least 80%, 85%, 90%, 95%, or more preferably 100%, identical to a CDR of a variable light chain region of the ESBA521 antibody.

Accordingly, particular antibodies or fragments of the invention comprise a variable heavy chain region that includes one or more complementarity determining regions (CDRs) that are at least 80%, 85%, 90%, 95%, or more preferably 100%, identical to a CDR of a variable heavy chain region of the ESBA521 and a variable light chain region that includes one or more CDRs that are at least 80%, 85%, 90%, 95% or more preferably 100%, identical to a CDR of a variable light chain region of the ESBA521 antibody.

The variable heavy chain region of the antibodies or antigen binding portions thereof can also include all three CDRs that are at least 80%, 85%, 90%, 95%, or more preferably 100%, identical to the CDRs of the variable heavy chain region of the ESBA521 antibody and/or all three CDRs that are at least 80%, 85%, 90%, 95% or more preferably 100%, identical to the CDRs of the variable light chain region of the ESBA521 antibody.

In another embodiment of the invention, the antibodies or antigen binding portions thereof (a) include a heavy chain variable region that is encoded by or derived from (i.e. is the product of) a human VH gene (e.g., H3 type); and/or (b) include a light chain variable region that is encoded by or derived from a human V kappa or lambda gene (e.g., lambda1 type).

The antibodies of the present invention include full-length antibodies, for example, monoclonal antibodies, that include an effector domain, (e.g., an Fc domain), as well as antibody portions or fragments, such as single-chain antibodies and Fab fragments. The antibodies can also be linked to a variety of therapeutic agents (e.g., anticancer agents, chemotherapeutics, or toxins) and/or a label (e.g., radiolabel).

In another aspect, the invention features isolated nucleic acids including a sequence encoding an antibody heavy chain variable region which is at least 75%, 80%, 85%, 90%, 95%, or more preferably at least 99%, identical to SEQ ID NO: 22. The invention also features isolated nucleic acids that include a sequence encoding an antibody light chain variable region which is at least 75%, 80%, 85%, 90%, 95%, or more preferably at least 99%, identical to SEQ ID NO: 21.

The invention also features expression vectors including any of the foregoing nucleic acids either alone or in combination (e.g., expressed from one or more vectors), as well as host cells comprising such expression vectors.

Suitable host cells for expressing antibodies of the invention include a variety of eukaryotic cells, e.g., yeast cells, mammalian cells, e.g., Chinese hamster ovary (CHO) cells, NS0 cells, myeloma cells, or plant cells. The molecules of the invention can also be expressed in prokaryotic cells, e.g., *E. coli*.

The invention also features methods for making the antibodies or antigen binding portions thereof by expressing nucleic acids encoding antibodies in a host cell (e.g., nucleic acids encoding the antigen binding region portion of an antibody). In yet another aspect, the invention features a hybridoma or transfectoma including the aforementioned nucleic acids.

In another embodiment, the invention provides an antigen comprising an epitope of the ALK protein, preferably of the PTN ligand binding domain, more preferably a fragment comprising, essentially consisting of or a fragment of the region spanning amino acid residues 391 ± 3 and 406 ± 3 (see SEQ. ID No: 91 which shows amino

acid residues 388 to 409 of the human ALK protein), most preferably amino acids 391-406 (SEQ. ID.No: 1). The antigen can be used for raising, screening, or detecting the presence of an anti-ALK antibody or can be used as an agent in active immunotherapy, i.e. as a vaccine.

As a vaccine, the antigen can be used alone or in combination with an appropriate adjuvant or haptent, e.g., mixed or conjugated either chemically or genetically. The antigen when used for active immunotherapy can also be used in combination with passive immunotherapy, for example, with any of the anti-ALK antibodies disclosed herein, or in combination with a monoclonal or polyclonal preparation of anti-ALK antibodies, e.g., serum gammaglobulin from a seropositive donor.

In another embodiment, the antibody molecules (or VL and VH binding regions) are fully human. Treatment of humans with human monoclonal antibodies offers several advantages. For example, the antibodies are likely to be less immunogenic in humans than non-human antibodies. The therapy is also rapid because ALK inactivation can occur as soon as the antibody reaches a cancer site (where ALK is expressed). Therefore, in a related embodiment, the antibody is a scFv antibody, i.e., ESBA521 or an antibody comprising a VL and/or VH region(s) (or CDRs thereof; e.g., VL CDR3 (SEQ ID NO:3) and/or VH CDR3 (SEQ ID NO: 2)) of ESBA521.

Human antibodies also localize to appropriate sites in humans more efficiently than non-human antibodies. Furthermore, the treatment is specific for ALK, is recombinant and highly purified and, unlike traditional therapies, avoids the potential of being contaminated with adventitious agents. Alternatively, antibodies and

antibody-derivatives of the present invention may be produced by chemical synthesis.

In another embodiment, the invention provides compositions for treating a cancer (or the making of a medicament so suited) that can prevent neoplasia in a subject by competing with ligands of ALK such as midkine (MK) and/or pleiotrophin (PTN) and thereby block ALK-signaling mediated by such ligands. Such composition can be administered alone or in combination with in the art recognized anti-cancer agents, for example, methotrexate, and the like.

The antibody of the invention and/or ALK vaccine can be used alone or in combined with a known therapeutic, e.g., an anti-cancer agent, e.g., methotrexate and the like.

Other features and advantages of the invention will be apparent from the following detailed description, and from the claims.

Brief Description of the Drawings

The invention will be better understood and objects other than those set forth above will become apparent when consideration is given to the following detailed description thereof. Such description makes reference to the annexed drawings, wherein:

Figure 1 shows a scheme of the human ALK protein used. A 16 amino acid peptide of the PTN binding site (dashed) is used as the epitope in a two hybrid screen for scFv binders.

Figure 2 shows the stepwise randomization of VH CDR3, VL CDR 3 and VH CDR 2 portions to obtain ESBA521

as secondary binder and a set of scFvs as tertiary binders (see Tab. 1). X stands for any amino acid residue.

Fig. 3 shows an ELISA experiment wherein the binding characteristics of improved scFvs are compared to that of the framework they originate from.

Fig. 4 shows immunostaining of transiently transfected HeLa cells with ESBA521 (left panels) and a polyclonal ALK specific antibody (right panels). Middle panel: same cells visualized by light microscopy.

Figure 5 shows an ELISA experiment comparing the ESBA512 to the improved tertiary binders.

Detailed Description of the Invention

In order that the present invention may be more readily understood, certain terms are first defined.

Definitions

The term "ALK" and "Alk-1" includes the human ALK protein encoded by the ALK (Anaplastic Lymphoma Kinase) gene which is a membrane-spanning protein tyrosine kinase (PTK)/receptor.

The term "antibody" refers to whole antibodies and any antigen binding fragment (*i.e.*, "antigen-binding portion," "antigen binding polypeptide," or "immunobinder") or single chain thereof. An "antibody" refers to a glycoprotein comprising at least two heavy (H) chains and two light (L) chains inter-connected by disulfide bonds, or an antigen binding portion thereof. Each heavy chain is comprised of a heavy chain variable region (abbreviated herein as V_H) and a heavy chain constant region. The heavy chain constant region is comprised of three domains, CH1, CH2 and CH3. Each light chain is comprised of a light chain variable region (abbreviated

herein as V_L) and a light chain constant region. The light chain constant region is comprised of one domain, CL. The V_H and V_L regions can be further subdivided into regions of hypervariability, termed complementarity determining regions (CDR), interspersed with regions that are more conserved, termed framework regions (FR). Each V_H and V_L is composed of three CDRs and four FRs, arranged from amino-terminus to carboxy-terminus in the following order: FR1, CDR1, FR2, CDR2, FR3, CDR3, FR4. The variable regions of the heavy and light chains contain a binding domain that interacts with an antigen. The constant regions of the antibodies may mediate the binding of the immunoglobulin to host tissues or factors, including various cells of the immune system (e.g., effector cells) and the first component (Clq) of the classical complement system.

The term "antigen-binding portion" of an antibody (or simply "antibody portion") refer to one or more fragments of an antibody that retain the ability to specifically bind to an antigen (e.g., ALK). It has been shown that the antigen-binding function of an antibody can be performed by fragments of a full-length antibody. Examples of binding fragments encompassed within the term "antigen-binding portion" of an antibody include (i) a Fab fragment, a monovalent fragment consisting of the V_L , V_H , CL and CH1 domains; (ii) a $F(ab')_2$ fragment, a bivalent fragment comprising two Fab fragments linked by a disulfide bridge at the hinge region; (iii) a Fd fragment consisting of the V_H and CH1 domains; (iv) a Fv fragment consisting of the V_L and V_H domains of a single arm of an antibody, (v) a single domain or dAb fragment (Ward et al., (1989) *Nature* 341:544-546), which consists of a V_H domain; and (vi) an isolated complementarity determining

region (CDR) or (vii) a combination of two or more isolated CDRs which may optionally be joined by a synthetic linker. Furthermore, although the two domains of the Fv fragment, V_L and V_H , are coded for by separate genes, they can be joined, using recombinant methods, by a synthetic linker that enables them to be made as a single protein chain in which the V_L and V_H regions pair to form monovalent molecules (known as single chain Fv (scFv); see e.g., Bird et al. (1988) *Science* 242:423-426; and Huston et al. (1988) *Proc. Natl. Acad. Sci. USA* 85:5879-5883). Such single chain antibodies are also intended to be encompassed within the term "antigen-binding portion" of an antibody. These antibody fragments are obtained using conventional techniques known to those with skill in the art, and the fragments are screened for utility in the same manner as are intact antibodies. Antigen-binding portions can be produced by recombinant DNA techniques, or by enzymatic or chemical cleavage of intact immunoglobulins. Antibodies can be of different isotype, for example, an IgG (e.g., an IgG1, IgG2, IgG3, or IgG4 subtype), IgA1, IgA2, IgD, IgE, or IgM antibody.

The term "frameworks" refers to the art recognized portions of an antibody variable region that exist between the more divergent CDR regions. Such framework regions are typically referred to as frameworks 1 through 4 (FR1, FR2, FR3, and FR4) and provide a scaffold for holding, in three-dimensional space, the three CDRs found in a heavy or light chain antibody variable region, such that the CDRs can form an antigen-binding surface. Such frameworks can also be referred to as scaffolds as they provide support for the presentation of the more divergent CDRs. Other CDRs and frameworks of the immunoglobulin superfamily, such as ankyrin repeats and fibronectin,

can be used as antigen binding molecules (see also, for example, U.S. Patent Nos. 6,300,064, 6,815,540 and U.S. Pub. No. 20040132028).

The term "epitope" or "antigenic determinant" refers to a site on an antigen to which an immunoglobulin or antibody specifically binds (e.g., ALK, for example, amino acid residues 391-406 of human ALK-1 (see e.g., SEQ ID NO: 1). An epitope typically includes at least 3, 4, 5, 6, 7, 8, 9, 10, 11, 12, 13, 14 or 15 amino acids in a unique spatial conformation. See, e.g., *Epitope Mapping Protocols in Methods in Molecular Biology*, Vol. 66, G. E. Morris, Ed. (1996).

The terms "specific binding," "selective binding," "selectively binds," and "specifically binds," refer to antibody binding to an epitope on a predetermined antigen. Typically, the antibody binds with an affinity (K_D) of approximately less than 10^{-7} M, such as approximately less than 10^{-8} M, 10^{-9} M or 10^{-10} M or even lower.

The term " K_D ," refers to the dissociation equilibrium constant of a particular antibody-antigen interaction. Typically, the antibodies of the invention bind to ALK with a dissociation equilibrium constant (K_D) of less than approximately 10^{-7} M, such as less than approximately 10^{-8} M, 10^{-9} M or 10^{-10} M or even lower, for example, as determined using surface plasmon resonance (SPR) technology in a BIACORE instrument.

The terms "neutralizes ALK," "inhibits ALK," and "blocks ALK" are used interchangeably to refer to the ability of an antibody of the invention to prevent ALK from interacting with one or more target ligands and, for example, triggering signal transduction.

The term "nucleic acid molecule," refers to DNA molecules and RNA molecules. A nucleic acid molecule

may be single-stranded or double-stranded, but preferably is double-stranded DNA. A nucleic acid is "operably linked" when it is placed into a functional relationship with another nucleic acid sequence. For instance, a promoter or enhancer is operably linked to a coding sequence if it affects the transcription of the sequence.

For nucleic acids, the term "substantial homology" indicates that two nucleic acids, or designated sequences thereof, when optimally aligned and compared, are identical, with appropriate nucleotide insertions or deletions, in at least about 80% of the nucleotides, usually at least about 90% to 95%, and more preferably at least about 98% to 99.5% of the nucleotides. Alternatively, substantial homology exists when the segments will hybridize under selective hybridization conditions, to the complement of the strand. Such hybridization conditions are known in the art, and described, e.g., in Sambrook et al. *infra*.

The percent identity between two sequences is a function of the number of identical positions shared by the sequences, taking into account the number of gaps, and the length of each gap, which need to be introduced for optimal alignment of the two sequences. The comparison of sequences and determination of percent identity between two sequences can be accomplished using a mathematical algorithm, as described in the non-limiting examples below.

The percent identity between two nucleotide sequences can be determined using the GAP program in the GCG software package, using a NWSgapdna. CMP matrix and a gap weight of 40, 50, 60, 70, or 80 and a length weight of 1, 2, 3, 4, 5, or 6. The percent identity between two nucleotide or amino acid sequences can also be determined

using the algorithm of E. Meyers and W. Miller (CABIOS, 4:11-17 (1989)) which has been incorporated into the ALIGN program (version 2.0), using a PAM120 weight residue table, a gap length penalty of 12 and a gap penalty of 4. In addition, the percent identity between two amino acid sequences can be determined using the Needleman and Wunsch (*J. Mol. Biol.* (48):444-453 (1970)) algorithm which has been incorporated into the GAP program in the GCG software package, using either a Blossum 62 matrix or a PAM250 matrix, and a gap weight of 16, 14, 12, 10, 8, 6, or 4 and a length weight of 1, 2, 3, 4, 5, or 6.

The nucleic acid and protein sequences of the present invention can further be used as a "query sequence" to perform a search against public databases to, for example, identify related sequences. Such searches can be performed using the NBLAST and XBLAST programs (version 2.0) of Altschul, et al. (1990) *J. Mol. Biol.* 215:403-10. BLAST nucleotide searches can be performed with the NBLAST program, score = 100, wordlength = 12 to obtain nucleotide sequences homologous to the nucleic acid molecules of the invention. BLAST protein searches can be performed with the XBLAST program, score = 50, wordlength = 3 to obtain amino acid sequences homologous to the protein molecules of the invention. To obtain gapped alignments for comparison purposes, Gapped BLAST can be utilized as described in Altschul et al., (1997) *Nucleic Acids Res.* 25(17):3389-3402. When utilizing BLAST and Gapped BLAST programs, the default parameters of the respective programs (e.g., XBLAST and NBLAST) can be used.

The present invention also encompasses "conservative sequence modifications" of the sequences set

forth in the SEQ ID NOs of the present invention, i.e., nucleotide and amino acid sequence modifications which do not abrogate the binding of the antibody encoded by the nucleotide sequence or containing the amino acid sequence, to the antigen. Such conservative sequence modifications include nucleotide and amino acid substitutions, additions and deletions. For example, modifications can be introduced by standard techniques known in the art, such as site-directed mutagenesis and PCR-mediated mutagenesis. Conservative amino acid substitutions include ones in which the amino acid residue is replaced with an amino acid residue having a similar side chain. Families of amino acid residues having similar side chains have been defined in the art. These families include amino acids with basic side chains (e.g., lysine, arginine, histidine), acidic side chains (e.g., aspartic acid, glutamic acid), uncharged polar side chains (e.g., glycine, asparagine, glutamine, serine, threonine, tyrosine, cysteine, tryptophan), nonpolar side chains (e.g., alanine, valine, leucine, isoleucine, proline, phenylalanine, methionine), beta-branched side chains (e.g., threonine, valine, isoleucine) and aromatic side chains (e.g., tyrosine, phenylalanine, tryptophan, histidine). Thus, a predicted nonessential amino acid residue in a human anti-ALK antibody is preferably replaced with another amino acid residue from the same side chain family. Methods of identifying nucleotide and amino acid conservative substitutions which do not eliminate antigen binding are well-known in the art (see, e.g., Brummell et al., *Biochem.* 32:1180-1187 (1993); Kobayashi et al. *Protein Eng.* 12(10):879-884 (1999); and Burks et al. *Proc. Natl. Acad. Sci. USA* 94:412-417 (1997))

Alternatively, in another embodiment, mutations are randomly introduced along all or part of an anti-ALK antibody coding sequence, such as by saturation mutagenesis, and the resulting modified anti-ALK antibodies can be screened for binding activity. A "consensus sequence" is a sequence formed from the most frequently occurring amino acids (or nucleotides) in a family of related sequences (See e.g., Winnaker, *From Genes to Clones* (Verlagsgesellschaft, Weinheim, Germany 1987). In a family of proteins, each position in the consensus sequence is occupied by the amino acid occurring most frequently at that position in the family. If two amino acids occur equally frequently, either can be included in the consensus sequence.

By reference to the tables and figures provided herein a consensus sequence for the antibody heavy / light chain variable region CDR(s) can be derived by optimal alignment of the amino acid sequences of the variable region CDRs of the antibodies which are reactive against epitope 390-406 of the human ALK-1 protein.

The term "vector," refers to a nucleic acid molecule capable of transporting another nucleic acid to which it has been linked. One type of vector is a "plasmid," which refers to a circular double stranded DNA loop into which additional DNA segments may be ligated. Another type of vector is a viral vector, wherein additional DNA segments may be ligated into the viral genome. Certain vectors are capable of autonomous replication in a host cell into which they are introduced (e.g., bacterial vectors having a bacterial origin of replication and episomal mammalian vectors). Other vectors (e.g., non-episomal mammalian vectors) can be integrated into the genome of a host cell upon introduction into the host

cell, and thereby are replicated along with the host genome.

The term "host cell" refers to a cell into which an expression vector has been introduced. Host cells can include bacterial, microbial, plant or animal cells. Bacteria, which are susceptible to transformation, include members of the enterobacteriaceae, such as strains of *Escherichia coli* or *Salmonella*; Bacillaceae, such as *Bacillus subtilis*; Pneumococcus; Streptococcus, and *Haemophilus influenzae*. Suitable microbes include *Saccharomyces cerevisiae* and *Pichia pastoris*. Suitable animal host cell lines include CHO (Chinese Hamster Ovary lines) and NS0 cells.

The terms "treat," "treating," and "treatment," refer to therapeutic or preventative measures described herein. The methods of "treatment" employ administration to a subject, in need of such treatment, an antibody of the present invention, for example, a subject having an ALK-mediated disorder or a subject who ultimately may acquire such a disorder, in order to prevent, cure, delay, reduce the severity of, or ameliorate one or more symptoms of the disorder or recurring disorder, or in order to prolong the survival of a subject beyond that expected in the absence of such treatment.

The term "ALK-mediated disorder" refers to disease states and/or symptoms associated with ALK-mediated cancers or tumors. In general, the term "ALK-mediated disorder" refers to any disorder, the onset, progression or the persistence of the symptoms of which requires the participation of ALK. Exemplary ALK-mediated disorders include, but are not limited to, for example, cancer, in particular, glioblastoma.

The term "effective dose" or "effective dosage" refers to an amount sufficient to achieve or at least partially achieve the desired effect. The term "therapeutically effective dose" is defined as an amount sufficient to cure or at least partially arrest the disease and its complications in a patient already suffering from the disease. Amounts effective for this use will depend upon the severity of the disorder being treated and the general state of the patient's own immune system.

The term "subject" refers to any human or non-human animal. For example, the methods and compositions of the present invention can be used to treat a subject with a cancer, e.g., glioblastoma.

Unless otherwise defined, all technical and scientific terms used herein have the same meaning as commonly understood by one of ordinary skill in the art to which this invention belongs. Although methods and materials similar or equivalent to those described herein can be used in the practice or testing of the present invention, suitable methods and materials are described below. In case of conflict, the present specification, including definitions, will control. In addition, the materials, methods, and examples are illustrative only and not intended to be limiting.

Various aspects of the invention are described in further detail in the following subsections. It is understood that the various embodiments, preferences and ranges may be combined at will. Further, depending of the specific embodiment, selected definitions, embodiments or ranges may not apply.

The present invention provides in a first aspect an antibody binding the human ALK protein, said antibody comprising a variable heavy chain CDR3 of a sequence with at least 50% sequence identity to the sequence SEQ. ID. No. 2. Preferably, the sequence identity is at least 60%, 70%, 75%, 80%, or more preferably at least 90%. Most preferably, the CDR3 has the precise sequence of SEQ. ID. No. 2.

In a preferred embodiment of the present invention the antibody binds specifically to the human ALK protein, i.e. it does not bind to the mouse ALK protein, whose PTN binding site differs in only 2 amino acid residues compared to the PTN binding site (SEQ. ID. No. 1) of the human ALK protein. The human isoleucine at position 3 is a valine and the aspartate is an alanine in the corresponding mouse sequence.

The antibody of the present invention can be a full-length antibody, but also an antibody fragment, such as for example a scFv or a Fab fragment. Antigen binding fragments are well known in the art. Preferably, a scFv antibody is used.

The heavy chain and the light chain are composed of framework sequences, each comprising three CDRs, CDR1, CDR2 and CDR3, which are predominantly involved in antigen binding. The antibody of the present invention comprises VH domain of the H3 type and a VL domain of the lambda1 type.

The VH and VL framework of the antibody of the present invention is stable and soluble so as to be functional in an intracellular reducing environment. Preferably it is the framework 4.4. that has previously been isolated by a yeast screening system referred to as the "Quality control system" (Auf der Maur et al., 2001;

Auf der Maur et al. 2004). The sequence of the framework can be deduced for example from SEQ. ID. No. 20 (see below), where the framework portions are represented by non-underlined and straight letters, while the CDR sequences are underlined and the linker sequence is in italics.

The antibody of the present invention is able to bind a 16-amino acid ALK epitope peptide of a sequence that is at least 75%, preferably 80%, 85%, 90%, 95%, or most preferably 100%, identical to the sequence of SEQ. ID. No. 1. This sequence is also referred to as PTN binding site and is a unique sequence in the entire human genome. The corresponding mouse sequence varies in 2 out of 16 amino acids, i.e., V at position 3 and A at position 7 instead of I or D, respectively. Preferably, the antibody of the present invention binds human but not mouse ALK, i.e., is specific for the human protein. The ALK epitope comprising about residues 391-406 or consisting of these residues is uniquely suited for selecting an antibody or antigen binding fragment that can specifically bind ALK and block or inhibit ALK-mediated activity. This epitope is also suitable for screening or raising antibodies that specifically block ALK activity. Thus, this epitope, especially an epitope comprising about residues 391-406 or consisting of about these residues, is uniquely suited for use as an active immunotherapeutic agent or vaccine as further described herein.

The antibody of the present invention has an affinity for the ALK epitope peptide with a K_D of 30 nM or less, preferably 10 nM or less, most preferably below 3 nM.

In another embodiment of the present invention, the antibody comprising a variable light chain CDR3

of a sequence with at least 50% sequence identity to the sequence SEQ.ID. No. 3. Preferably, the sequence identity is at least 60%, 70%, 80%, 85%, more preferably at least 90%. Most preferably, CDR3 is identical to SEQ. ID. No. 3. Again, this antibody binds a 16-amino-acid ALK epitope peptide of a sequence with at least 75%, preferably 80%, 85%, 90%, 95%, or most preferably 100%, amino acid identity to the sequence SEQ.ID. No. 1. Also, the antibody has an affinity for the ALK epitope peptide with a K_d of less than 10 nM, preferably less than 7 nM.

In a preferred embodiment of the present invention the antibody comprises a VH sequence of SEQ.ID. No. 4 and a VL sequence of SEQ.ID. No. 5. Additionally, it can comprise at least one mutation in at least one of the CDRs resulting in a higher affinity characterized by a K_d of less than about 3 nM. Said at least one mutation is preferably in CDR1 or CDR2 of VH and/or VL, most preferably in CDR2 of VH.

In another preferred embodiment of the present invention the antibody comprises a variable heavy chain CDR2 comprising a sequence selected from the group of SEQ. ID. No. 7, SEQ.ID. No. 8, SEQ. ID. No. 9, SEQ.ID. No. 10, SEQ.ID. No. 11, SEQ.ID. No. 12, or SEQ.ID. No. 13. Preferably these defined CDR2 sequences are preceded by the amino acids residues AI and followed by the sequences of SEQ.ID. No. 17, so that the entire CDR2 is defined.

A preferred antibody of the present invention comprises a VH sequence of SEQ. ID. No. 4 and a VL sequence of SEQ. ID. No. 5. In scFv antibodies, the domain structure can NH_2 -VL-linker-VH-COOH or NH_2 -VH-linker-VL-COOH; preferably, the linker has the sequence SEQ. ID. No. 16. Alternatively, the variable regions represented

by SEQ ID NOS: 4 and 5 can be engineered into a full length antibody, e.g., IgG or IgM. Constant regions suitable for combining with the variable regions of the invention are known in the art.

Within the scope of the present invention is the use of the antibody or antibody derivative as a medicament or as a diagnostic tool. Preferably, the production of a medicament for the treatment of cancers or tumors is envisaged. For this purpose an antibody can be radiolabelled using radionuclides or radiometal labeling. This is particularly valuable for tumor targeting, imaging and biodistribution studies. Also, recombinant DNA technology makes it possible to genetically fuse coding regions of variable V genes to modified toxin domains. For example, a scFv-toxin fusion wherein the scFv is specific for a tumor marker protein can target the toxin to the tumor, where the toxin causes cytotoxicity. Such targeted therapy results in the selective concentration of cytotoxic agents or radionuclides in tumors and should lessen the toxicity to normal tissues.

In a preferred embodiment of the present invention the antibody is used for a treatment of cancers or tumors, preferably neuroblastoma, glioblastoma, rhabdomyosarcoma, breast carcinoma, melanoma, pancreatic cancer, B-cell non-Hodgkin's lymphoma, thyroid carcinoma, small cell lung carcinoma, retinoblastoma, Ewing sarcoma, prostate cancer, colon cancer, or pancreatic cancer, preferably glioblastoma, neuroblastoma and rhabdomyosarcoma. ALK expression and protein has been detected in many soft tissue tumors (Li et al., 2004). Full-length ALK has been found in these human tumors. Furthermore, the antibody is preferably used for local treatments. Most preferred is local treatment of glioblastoma.

Another aspect of the present invention is to provide a DNA sequence encoding the antibody of the present invention. A suitable prokaryotic expression vector for ESBA512 (SEQ.ID.No: 19) is pTFT74 (see SEQ.ID.No: 90 for the sequence including the ESBA512 coding sequence). Therein, the ESBA512 coding sequence is under the control of the T7-promotor and the recombinant gene product is usually purified over inclusion bodies. Another preferred prokaryotic expression vector is pAK400, wherein the ESBA512 sequence is his-tagged for simplified purification (see SEQ.ID.No: 89 for the sequence including the ESBA512 coding sequence). The gene product is secreted by the host cell into the periplasm.

In addition, an expression vector comprising said DNA sequence and a suitable host cell transformed with said expression vector is provided. Preferably, said host cell is an E. coli cell.

Yet another aspect of the present invention is the production of the antibody of the present invention, comprising culturing the host cell that is transformed with the expression vector for said antibody, under conditions that allow the synthesis of said antibody and recovering it from said culture.

Another aspect of the present invention is to provide an ALK epitope, comprising or consisting essentially of residues 391-406 of SEQ ID NO: 1. Said epitope is suitable for identifying, screening, or raising anti-ALK antibodies or fragments thereof. Preferably, the antibody or antigen binding fragment thereof that is capable of specifically binding residues 391-406 (SEQ ID NO:1) of an isolated ALK protein or fragment thereof. More preferably, the antibody is a single chain antibody (scFv), Fab fragment, IgG, or IgM.

In a further aspect, an ALK vaccine comprising an isolated ALK protein or a fragment thereof, or a nucleic acid encoding an epitope of ALK is provided. Preferably, the vaccine comprises residues 391-406 of an isolated ALK protein. Said vaccine is preferably formulated with a carrier, adjuvant, and/or hapten to enhance the immune response.

The sequences of the present invention are the following ones:

SEQ.ID. No. 1: GRIGRPDNPFRVALEY

Human ALK epitope peptide (amino acids 391-406 of the ALK protein); underlined residues are different in the mouse homologue.

SEQ.ID. No. 2: RDAWLDVLS^USDGFDY

ESBA521 CDR 3 of VH. Residues obtained after randomization are underlined.

SEQ.ID. No. 3: ATWDNDK^UWGVV

ESBA521 CDR 3 of VL. Residues obtained after randomization are underlined.

SEQ.ID. No. 4:

EVQLVESGGGLVQPGGSLRLSCAASGFTFSSYAMSWVRQAPGKGLEWVSAISGSGGS
 TYYADSVKGRFTISRDNKNTLYLQMNSLRAEDTAVYYCARD^UAWLDVLS^UDGFDYWGQ
 GTLVTVSS

VH of ESBA521. CDRs are underlined.

SEQ.ID. No. 5:

QSVLTQPPSVSAAPGQKVTISCSG^USTSNIGD^UNYVSWYQQLPGTAPQLLIYD^UNTKRPS
 GIPDRFSGSKSGTSATLGITGLQTGDEADYYCATWDNDK^UWGVV^UFGGGTKLEVLG

'36

VL of ESBA521. CDRs are underlined.

SEQ.ID. No. 6:

AISGSGGSTYYADSVKG

VH CDR 2 of ESBA521

SEQ.ID. No. 7:

AINMKGNDRYYADSVKG

VH CDR 2 of scFv 265.1

SEQ.ID. No. 8:

AIRTNSKEYYADSVKG

VH CDR 2 of scFv 43.2

SEQ.ID. No. 9

AIKTDGNHKYYADSVKG

VH CDR 2 of scFv 100.2

SEQ.ID. No. 10:

RTDSKEQYYADSVKG

VH CDR 2 of scFv 2.11

SEQ.ID. No. 11:

ETSSGSTYYADSVKG

VH CDR 2 of scFv 28.11

SEQ.ID. No. 12:

NTGGGSTYYADSVKG

VH CDR 2 of scFv 33.11

SEQ.ID. No. 13:

NTRGQNEYADSVKG

VH CDR 2 of scFv 4.12

SEQ.ID. No. 16

GGGGSGGGSGGGSSGGGS

Linker connecting VL and VH

SEQ.ID. No. 17

YYADSVKG

C-terminal half of CDR2 of ESBA521 and its derivatives.

SEQ.ID. No. 18

DAGIAVAGTGFDY

VH CDR3 of FW4.4

SEQ.ID. No. 19

QSVLTQPPSVSAAPGQKVTISCSGSTSSNIGDNYVSWYQQLPGTAPQLLIYDNTKRPS
 GIPDRFSGSKSGTSATLGITGLQTGDEADYYCATWDNDKWGVVFGGGTKLEVLGGGG
 GSGGGSGGGSSGGGSEVQLVESGGGLVQPGGSLRLSCAASGFTFSSYAMSWVROA
 PGKGLEWVSAISGGSTYYADSVKGRFTISRDNKNTLYLQMNSLRAEDTAVYYCA
RDWLDVLSDGFDYWGQTLVTVSS

scFv ESBA521, CDRs underlined, linker in italics

SEQ. ID. No. 20

QSVLTQPPSVSAAPGQKVTISCSGSTSSNIGDNYVSWYQQLPGTAPQLLIYDNTKRPS
 GIPDRFSGSKSGTSATLGITGLQTGDEADYYCGTWDSSLSGVVFGGGTKLTVLGGGG
 GSGGGSGGGSSGGGSEVQLVESGGGLVQPGGSLRLSCAASGFTFSSYAMSWVROA
 PGKGLEWVSAISGGSTYYADSVKGRFTISRDNKNTLYLQMNSLRAEDTAVYYCA
RDAGIAVAGTGFDYWGQTLVTVSS

FW4.4, CDRs are underlined, linker in italics

SEQ ID No. 21

cagtctgtgctgacgcagccgccctcagtgtctgcgccccagga
 cagaaggtcaccatctcctgctccggaagcacctccaacattggcgataattatgta
tccctggtaccaacaactcccaggaacagcccccaactcctcatttatgacaatact
aaacgaccctcagggattcctgaccggttctctggctccaagtctggcacgtcagcc
 accctgggcatcaccggactccagactggggacgaggccgattattactgcgcgacc
 tgggataatgataagtggggtgtggttttcggcggagggaccaagctcgaggtcc-
 taggt

Nucleic acid sequence of ESBA521 VL
 CDRs are underlined

SEQ ID No. 22

gaggtgcagctggtggagtccgggggaggcttggtacagcctggg
 gggccctgagactctcctgtgcagcctctggattcacctttagcagctatgccatg
agctgggtccgccaggctccaggaaggggctggagtgggtctcagctattagtggg
agtgggtggtagcacatactacgcagactccgtgaagggccggttcaccatctccaga
 gacaattccaagaacacgctgtatctgcaaatgaacagcctgagagccgaggacacg
 gccgtatattactgcgcgctgatgcgtggttggtatgtgctttcggatggctttgac
tactggggccagggaaaccctggtcaccgtctcctcg

Nucleic acid sequence of ESBA521 VH
 CDRs are underlined

SEQ ID No. 23

cagtctgtgctgacgcagccgccctcagtgtctgcgccccagga
 cagaaggtcaccatctcctgctccggaagcacctccaacattggcgataattatgta
tccctggtaccaacaactcccaggaacagcccccaactcctcatttatgacaatact
aaacgaccctcagggattcctgaccggttctctggctccaagtctggcacgtcagcc
 accctgggcatcaccggactccagactggggacgaggccgattattactgcgcgacc
 tgggataatgataagtggggtgtggttttcggcggagggaccaagctcgaggtccta
 ggtggtggtggtggttcggtggtggtggttctggcggcggcggctccagtgggtggt
 ggatccgaggtgcagctggtggagtccgggggaggcttggtacagcctgggggggtcc
 ctgagactctcctgtgcagcctctggattcacctttagcagctatgccatgagctgg
 gtccgccaggctccaggaaggggctggagtgggtctcagctattagtggtagtggg
ggttagcacatactacgcagactccgtgaagggccggttcaccatctccagagacaat

tccaagaacacgctgtatctgcaaataaacagcctgagagccgaggacacggccgta
tattactgcgcgcgatgacgtggttgatgtgctttcggatggctttgactactgg
ggccaggggaaccctgggtcacccgtctcctcg

Nucleic acid sequence of ESBA521

CDRs are underlined, linker in italics

The invention is now further described by means of examples:

Materials and Methods

In general, the practice of the present invention employs, unless otherwise indicated, conventional techniques of chemistry, molecular biology, recombinant DNA technology, immunology (especially, e.g., antibody technology), and standard techniques in polypeptide preparation. See, e.g., Sambrook, Fritsch and Maniatis, *Molecular Cloning: Cold Spring Harbor Laboratory Press* (1989); *Antibody Engineering Protocols (Methods in Molecular Biology)*, 510, Paul, S., Humana Pr (1996); *Antibody Engineering: A Practical Approach* (Practical Approach Series, 169), McCafferty, Ed., Irl Pr (1996); *Antibodies: A Laboratory Manual*, Harlow et al., C.S.H.L. Press, Pub. (1999); and *Current Protocols in Molecular Biology*, eds. Ausubel et al., John Wiley & Sons (1992).

Experiment 1: Screening to identify Alk-binding scFvs

In a wealth of structural studies on antibody-antigen interactions it was found that residues in the complementarity-determining region 3 (CDR-H3) of the heavy chain generally contribute the most substantial contacts to the antigen (Chothia and Lesk, 1987; Chothia

et al., 1985; Padlan, 1994). We applied our recently described yeast two-hybrid antigen-antibody interaction screening technology to directly isolate antigen-binding scFvs by screening of four scFv libraries of randomized synthetic CDR-H3 sequences (Auf der Maur et al., 2002). The four libraries are based on four different stable human scFv frameworks in which 7 amino acids within the third CDR loop of the variable heavy chain (VH-CDR3) were randomized. The randomized parts were introduced by standard PCR cloning techniques. The scFv libraries were screened against a 16 amino acid peptide derived from the extracellular domain of the human tyrosine receptor kinase Anaplastic Lymphoma Kinase (ALK) by a yeast screening system called "Quality Control" (Auf der Maur et al., 2001; Auf der Maur et al., 2004). Briefly, the Quality Control technology is an antigen-independent intrabody selection system for identifying from a natural pool of human variable-light (VL) and variable-heavy (VH) chains those VL and VH combinations with favourable biophysical properties, such as stability, solubility and expression yield. One promising and specific binder from one of the four scFv libraries was isolated after the first screening round. This particular scFv was derived from the framework FW4.4 library. FW4.4 (SEQ. ID. No. 20) consists of a VL domain (λ 1) connected by a classical flexible glycine-serine linker (GGGGS)₄ to a VH₃ domain. The VH CDR3 of FW4.4 comprises 13 amino acids (DAGIAVAGTGFDY; SEQ.ID. No. 18). To construct the library, the central part of the VH CDR3 (DAXXXXXXXXXGFDY) was randomized by standard PCR-cloning methods using a degenerated oligonucleotide. The last two residues (Asp and Tyr) were kept constant, because their structural importance was demonstrated in many cases (Chothia and

Lesk, 1987). The remaining residues were not modified in order to keep the complexity of the library in manageable dimensions. The scFv library was cloned in a yeast expression vector (pLib1) as C-terminal fusion to the transcriptional activation domain of Gal4 (Auf der Maur et al., 2002).

The ligand-binding domain (LBD) of human Alk was chosen as antigen for the interaction screen (Stoica et al., 2001). This 16 amino acid peptide was cloned into another yeast expression vector (pBait1) as C-terminal fusion to the DNA-binding protein LexA.

The reporter yeast strain YDE173 (Auf der Maur et al., 2002) containing the stably integrated reporter genes *HIS3* and *lacZ* under the control of six LexA-binding sites was transformed with the bait vector expressing the Alk LBD fused to LexA together with the random CDR-H3 scFv library fused to the Gal4 activation domain. Transformed cells were selected on plates lacking histidine and containing 2.5 mM 3-amino-triazole (3-AT), which is a competitive inhibitor of the *HIS3* gene product. Growing colonies were picked over a period of six days and the library plasmids were isolated. The same reporter strain was transformed with the rescued plasmids to confirm antigen-dependent gene activation. A quantitative liquid β -galactosidase assay was performed to measure binding-strength between the Alk LBD, i.e. the 16 amino acid ALK peptide, and the selected scFv. The scFv with highest reporter gene activation also demonstrated best affinity (~31nM) for the Alk LBD peptide in ELISA (data not shown).

The sequences of other VH CDR3 sequences identified as contributing to ALK binding are provided below in Table 1a.

clone	VH CDR 3 (mutated residues)
WT FW4.4	DAGIAVAGTGFDY (SEQ. ID. No. 24)
H5 SH 2.1	DAKFMSDGGIGFDY (SEQ. ID. No. 25)
H5 SH 4.1	DAWGWTILSGFDY (SEQ. ID. No. 26)
H5 SH 5.1	DAAYMIRYEGFDY (SEQ. ID. No. 27)
H5 SH 2.3	DAWIYWAREGFDY (SEQ. ID. No. 28)
H5 SH 3.3	DACMTYSREGFDY (SEQ. ID. No. 29)
H5 SH 5.3	DAWLDVLSDGFDY (SEQ. ID. No. 30)
H5 SH 14.3	DAPSVNDREGFDY (SEQ. ID. No. 31)

The sequences of other suitable frameworks are provided below in Table 1b.

FW	Sequence
5.2	EIVLTQSPATLSLSPGERATLSCRASQTLTHYLAWYQOKPGQAPRLLIYD TSKRATGTPARFSGSGSSTDFTLTISSLEPEDSALYICQQRNSWPHTFGG GTKLEIKRGGGGSGGGSSGGGSEVQLVESGGGVAQPGGSLRVS CAASGFSFSSYAMQWVRQAPGKGLEWVAVISNDGRIEHYADAVRGRFTIS RDNSQNTVFLQMNSLRSDDTALYYCAREIGATGYLDNWGQGTLVTVSS (SEQ. ID. No. 15)

Experiment 2: Affinity maturation

In order to obtain an scFv with higher affinity, this primary binder was subjected to a further affinity maturation process by mutagenesis and a second screening round in yeast. Enabling affinity maturation, the expression level of the LexA Alk LBD peptide fusion protein was reduced in order to lessen reporter gene activation driven by the interaction of the primary binder with the Alk LBD peptide. The strong actin promoter on the pBait1 vector was exchanged with the truncated and thus less active version of the ADH promoter (alcohol dehydrogenase) resulting in pBait3. This reduction of the bait expression level, in the presence of the primary binder, was sufficient to inhibit growth on plates lacking histidine and containing 5 mM 3-AT. Mutagenesis of the primary

binder for affinity maturation was accomplished by randomizing parts of the CDR3 within the variable light chain. This was performed directly in yeast by homologous recombination (Schaerer-Brodbeck and Barberis, 2004). The VL CDR3 of FW4.4 comprises 11 amino acids (SEQ. ID. No. 14: GTWDSSLSGVV). The first two positions were partially randomized, such that the first position either encodes Gly, Ala or Gln, and the second position Thr, Ser or Ala. At the positions 5 to 8 within VL CDR3 all amino acid residues were allowed. The remaining positions were kept constant. Randomization was introduced by PCR. The resulting PCR product had a size of 356 bp and comprised the randomized CDR cassette with 267 bp upstream and 27 bp downstream framework sequences. This product is the so-called donor PCR fragment, which bears homologies to the target vector. The target vector is the yeast plasmid (pLib1) encoding the primary binder fused to the activation domain of Gal4. In order to improve efficiency of homologous recombination and to exclude false positives in the subsequent screening, the CDR-L3 in the target vector was slightly modified. A unique *SacI* restriction site was introduced in the middle of VL CDR3, which leads to a frameshift in the scFv encoding part of the fusion protein and results in a truncated protein unable to bind to the Alk LBD. In addition, the *SacI* site enables linearization of the target vector, which enhances recombination efficiency in yeast.

The screening was launched by pre-transformation of the reporter yeast strain YDE173 with the plasmid (pBait3) expressing the LexA Alk LBD from the truncated ADH promoter. This pre-transformed yeast cells were made competent again and co-transformed with the linearized target vector and with the donor PCR fragment,

which bears homologies upstream and downstream of the VL CDR3. Upon homologous recombination between the PCR product and the target vector, the novel VL CDR3 sequence is integrated into the corresponding site of the target vector. As a net result of this event the primordial VL CDR3 gets exchanged with the randomized VL CDR3. This allows reconstitution of a circular plasmid that expresses a fully functional fusion protein with a novel VL CDR3 sequence, which will activate reporter gene expression and enable growth on selective plates upon interaction with the Alk LBD peptide.

A total of 119 clones grew on selective plates over an observation period of 6 days. These clones were picked and the library plasmids were isolated and retransformed into the same reporter yeast strain. A quantitative liquid β -galactosidase assay was performed to measure binding strength between the Alk LBD (antigen) and the affinity-matured scFv. 20 clones with highest *lacZ* activation were also tested in ELISA with Alk LBD peptide. The best candidate revealed a K_D of about 7nM (Fig. 3) and was named ESBA521.

The sequences of other VL CDR3 sequences identified as contributing to ALK binding are provided below in Table 1c.

clone	VL CDR 3
WT FW4.4	GTWDSLSLGGVV (SEQ. ID. No. 32)
5.3-9.1	AAWDSVKHGGVV (SEQ. ID. No. 33)
5.3-21.1	AAWDNSMRGGVV (SEQ. ID. No. 34)
5.3-22.1	AAWDTMRYGGVV (SEQ. ID. No. 35)
5.3-25.1	AAWDTTRVGGVV (SEQ. ID. No. 36)
5.3-27.1	ASWDTMLKGGVV (SEQ. ID. No. 37)
5.3-28.1	ASWDTPTCGVV (SEQ. ID. No. 38)
5.3-29.1	ATWDISRCGGVV (SEQ. ID. No. 39)
5.3-46.1	ATWDTVCAGVV (SEQ. ID. No. 40)
5.3-53.1	ATWDDVDFGGVV (SEQ. ID. No. 41)

5.3-57.1	ATWDDVVGGVV (SEQ. ID. No. 42)
5.3-86.1	AAWDSFYNGVV (SEQ. ID. No. 43)
5.3-94.1	ASWDTLIEGVV (SEQ. ID. No. 44)
5.3-107.1	ATWDNDKNGVV (SEQ. ID. No. 45)
5.3-112.1	AAWDSTTCGVV (SEQ. ID. No. 46)
5.3-113.1	ATWDMWMKGVV (SEQ. ID. No. 47)
5.3-117.1	GTWDSLSLGGVV (SEQ. ID. No. 48)
5.3-118.1	AAWDWVLGGVV (SEQ. ID. No. 49)
14.3-6.1	ATWDNPGQGVV (SEQ. ID. No. 50)
14.3-7.1	ATWDDWVIGVV (SEQ. ID. No. 51)
14.3-8.1	ASWDDQKNGVV (SEQ. ID. No. 52)
14.3-9.1	ATWDTNRHGVV (SEQ. ID. No. 53)
14.3-12.1	ASWDDLHIGVV (SEQ. ID. No. 54)
14.3-13.1	ASWDEEAWGVV (SEQ. ID. No. 55)
14.3-21.1	ATWDYIKIGVV (SEQ. ID. No. 56)
14.3-48.1	ATWDTFERGVV (SEQ. ID. No. 57)
14.3-49.1	ATWDSNLIGVV (SEQ. ID. No. 58)
5.3-24.,1	ATWDNNTCGVV (SEQ. ID. No. 59)
5.3-3.1	AAWDCDINGVV (SEQ. ID. No. 60)
5.3-8.1	ASWDSMKIGVV (SEQ. ID. No. 61)
5.3-19.1	ATWDCTRAGVV (SEQ. ID. No. 62)

Experiment 3: The scFv ESBA521 specifically binds to the transmembrane form of human ALK

In order to test whether the newly identified scFv was able to also recognize the transmembrane human ALK protein on the surface of living cells, immunostaining experiments of transiently transfected HELA cells were performed. ESBA521 reacts with the ALK protein in a comparable way as a polyclonal antibody (Fig. 4). In a control experiment it was shown that the framework 4.4 scFv does not react with human ALK. Surprisingly, ESBA521 only binds to the human Alk protein, but not to the corresponding mouse protein, although the mouse antigenic peptide only differs in two amino acid positions from the human peptide sequence. By contrast, the polyclonal ALK antibody recognizes both human and mouse protein. Therefore, binding of ESBA521 is specific for the human ALK protein at the cell surface.

Experiment 4: Isolation of improved binders
by PCR mutagenesis of VH CDR 2

To further improve antigen binding, ESBA521 was used as the starting scFv in a further round of affinity maturation using the same two-hybrid approach as described for the first round of affinity maturation, except in this case CDR2 of VH was changed by PCR mutagenesis and transformed into the yeast recipient, wherein homologous recombination at CDR2 is enforced in analogous way. Again, a restriction site was introduced in CDR2 to enable linearization of the target plasmid. The mutations introduced in CDR2 are given in Table 2.

scFv (performing best)	VH CDR 2 (mutated residues)
WT (ESBA521)	AISGSGGSTYYADSVKG (SEQ. ID. No. 63)
1.1	AI-KTDGQNYADSVKG (SEQ. ID. No. 64)
17.1	AIRSDGNERYYADSVKG (SEQ. ID. No. 65)
35.1	AINTNGNEKYYADSVKG (SEQ. ID. No. 66)
64.1	AISTNGKERYADSVKG (SEQ. ID. No. 67)
130.1	AIRTQSQEEYYADSVKG (SEQ. ID. No. 68)
152.1	AIKRSRSEQYYADSVKG (SEQ. ID. No. 69)
167.1	AIKSHSQQYYADSVKG (SEQ. ID. No. 70)
214.1	AINSEGQQRYYADSVKG (SEQ. ID. No. 71)
225.1	AIKSKGQNKYYADSVKG (SEQ. ID. No. 72)
262.1	AIRTNSEEKYYADSVKG (SEQ. ID. No. 73)
265.1	AINMKGNDRYADSVKG (SEQ. ID. No. 74)
43.2	AI-RTNSKEYADSVKG (SEQ. ID. No. 75)
70.2	AIKTESQQRYYADSVKG (SEQ. ID. No. 76)
99.2	AINSNGKQDYYADSVKG (SEQ. ID. No. 77)
100.2	AIKTDGNHKKYYADSVKG (SEQ. ID. No. 78)
109.2	AIDTKGNGQYYADSVKG (SEQ. ID. No. 79)
146.2	AIRSDSSHKYYADSVKG (SEQ. ID. No. 80)
173.2	AINTKSNEQYYADSVKG (SEQ. ID. No. 81)
199.2	AIRTDKNSYYADSVKG (SEQ. ID. No. 82)
2.11	AIRTDKSEQYYADSVKG (SEQ. ID. No. 83)
19.11	AIRTNSKEEYYADSVKG (SEQ. ID. No. 84)
28.11	AIETSSGSTYYADSVKG (SEQ. ID. No. 85)

33.11	AINTEGGGSTYYADSVKG (SEQ. ID. No. 86)
4.12	AINTRGQNEYADSVKG (SEQ. ID. No. 87)
6.12	AISTSG-STYYADSVKG (SEQ. ID. No. 88)

Among the isolated scFvs obtained after this procedure, seven turned out to have significantly improved affinity with a K_d in the range of 2-3 nM (Fig. 5), the best of them being 28.11.

Experiment 5: Prevention of tumor-growth upon administration of anti-ALK antibody

The progenitors of the antibody ESBA521 were selected to bind to amino acids 391-406 of ALK, which comprises the amino acids (396-406) that are known to bind pleiotrophin (Stoica 2001). ESBA521 was obtained by randomizing additional amino acids in the CDRs of its progenitor and by selecting for binders that bind to the 391-406 amino acid stretch contained in its natural context of the ALK extracellular domain (ECD). These proceedings resulted in an antibody, which binds the ALK ECD with high affinity at the same site that binds PTN. To our knowledge. This is the first monoclonal antibody that specifically targets the PTN binding site of ALK. Accordingly, ESBA521 is predicted to have high affinity to the ALK ECD and efficiently competes with pleiotrophin (PTN) and midkine (MK) for binding to the ALK receptor, and thus, the ESBA521 antibody is suitable for inhibiting both MK and PTN ligand binding to the ALK protein.

Because ALK and its ligands are involved in neoplasia, tumor invasion and angiogenesis, inhibition of the interaction between ALK and its cognate ligands disrupts ALK mediated tumorigenesis.

The effect of ESBA521 on a specific tumor can be determined by the following two assays described below.

In a first assay, xenograft experiments are prepared in order to determine the cancer growth rate-limiting role of ALK (Powers 2002). Briefly, a U87MG cell suspension of 20 million cells/ml media supplemented with 10% fetal calf serum are prepared. These are injected into NU/NU mice and resultant tumors are measured. Test antibodies, preferably full length antibodies, more preferably, pegylated antibodies, are introduced and tumor growth is assessed.

While there are shown and described presently preferred embodiments of the invention, it is to be distinctly understood that the invention is not limited thereto but may be otherwise variously embodied and practiced within the scope of the following claims.

References:

Auf der Maur, A., Escher, D., and Barberis, A. (2001). Antigen-independent selection of stable intracellular single-chain antibodies. *FEBS Lett* 508, 407-412.

Auf der Maur, A., Tissot, K., and Barberis, A. (2004). Antigen-independent selection of intracellular stable antibody frameworks. *Methods* 34, 215-224.

Auf der Maur, A., et al., Direct in vivo screening of intrabody libraries constructed on a highly

stable single-chain framework. *J Biol Chem*, 277(47): p. 45075-85, 2002.

Bai RY. et al. Nucleophosmin-anaplastic lymphoma kinase associated with anaplastic large-cell lymphoma activates the phosphatidylinositol 3-kinase/Akt antiapoptotic signalling pathway. *Blood* 96(13), 4319-4327, 2000.

Bowden et. et al. Anti-apoptotic signaling of pleiotrophin through its receptor, anaplastic lymphoma kinase. *The Journal of Biological Chemistry* 277(39), 35862-35868, 2002.

Chothia, C., and Lesk, A. M. (1987). Canonical structures for the hypervariable regions of immunoglobulins. *J. Mol. Biol.* 196, 901-917.

Chothia, C., Novotny, J., Bruccoleri, R., and Karplus, M. (1985). Domain association in immunoglobulin molecules. The packing of variable domains. *J. Mol. Biol.* 186, 651-663.

Choudhuri et al., An Angiogenic Role for the Neurokines Midkine and Pleiotrophin in Tumorigenesis. *Cancer Res.* 57, 1814-1819, 1997.

Czubayko et al., Melanoma angiogenesis and metastasis modulated by ribozyme targeting of the secreted growth facator pleiotrophin. *PNAS* 93, 14753-14758, 1996.

De Juan C. et al. Genomic organization of a novel glycosylphosphatidylinositol MAM gene expressed in human tissues and tumors. *Oncogene* 21, 3089-3094, 2002.

Delsol G. et al. A new subtype of large B-cell lymphoma expressing the ALK kinase and lacking the 2;5 translocation. *Blood* 89(5), 1483-1490, 1997.

Dirks WG. et al. Expression and functional analysis of the anaplastic lymphoma kinase (ALK) gene in tumor cell lines. *International Journal of cancer* 100, 49-56, 2002.

Duyster J. et al. Translocations involving anaplastic lymphoma kinase (ALK). *Oncogene* 20, 5623-5637, 2001.

Ergin M. et al. Inhibition of tyrosine kinase activity induces caspase-dependent apoptosis in anaplastic large cell lymphoma with NPM-ALK (p80) fusion protein. *Experimental Hematology* 29, 1082-1090, 2001.

Fang et al., Pleiotrophin stimulates fibroblasts and endothelial and epithelial cells and is expressed in human cancer. *JBC* vol. 267 p. 25889, 1992.

Fiorani C. et al. Primary systemic anaplastic large-cell lymphoma (CD30+): advances in biology and current therapeutic approaches. *Clinical Lymphoma* 2(1), 29-37, 2001.

Iwahara T. et al. Molecular characterization of ALK, a receptor tyrosine kinase expressed specifically in the nervous system. *Oncogene* 14, 439-449, 1997.

Kutok JL. and Aster JC. Molecular biology of anaplastic lymphoma kinase-positive anaplastic large-cell lymphoma. *Journal of Clinical Oncology* 20(17), 3691-3702, 2002.

Ladanyi M. Aberrant ALK tyrosine kinase signalling. Different cellular lineages, common oncogenic mechanisms? *American Journal of Pathology* 157(2), 341-345, 2000.

Lamant et al. Expression of the ALK tyrosine kinase gene in neuroblastoma. *Am. J. Pathol.* 156, 1711-1721, 2000.

Li, X.-Q., Hisaoka, M., Shi, D.-R., Zhu, X.-Z., and Hashimoto, H. Expression of Anaplastic Lymphoma Kinase in soft tissue tumors: an immunohistochemical and molecular study of 249 cases. *Human pathology* 35, 711-721, 2004.

Loren CE. et al. Identification and characterization of Dalk: a novel *Drosophila melanogaster* RTK which drives ERK activation in vivo. *Genes to cells* 6(6), 531-544, 2001.

Miyake I. et al. Activation of anaplastic lymphoma kinase is responsible for hyperphosphorylation

of ShcC in neuroblastoma cell lines. *Oncogene* 21, 5823-5834, 2002.

Morris SW. et al. ALK, the chromosome 2 gene locus altered by the t(2;5) in non-Hodgkin's lymphoma, encodes a novel neural receptor tyrosine kinase that is highly related to leukocyte tyrosine kinase (LTK). *Oncogene* 14, 2175-2188, 1997.

Morris SW. et al. ALK+CD30+ lymphomas: A distinct molecular genetic subtype of non-Hodgkin's lymphoma. *British Journal of Haematology* 113, 275-295, 2001.

O'Brien et al., The angiogenic factor midkine is expressed in bladder cancer and overexpression correlates with a poor outcome in patients with invasive cancer. *Cancer Res.* 56, 2515-2518, 1996.

Padlan, E. A. (1994). Anatomy of the antibody molecule. *Mol Immunol* 31, 169-217.

Powers C. et al. Pleiotrophin signalling through anaplastic lymphoma kinase is rate-limiting for glioblastoma growth. *The Journal of biological chemistry* 277(16), 14153-14158, 2002.

Pulford K. et al. Anaplastic lymphoma kinase proteins and malignancy. *Current Opinion in Hematology* 81, 231-236, 2001.

Pulford K. et al. Anaplastic lymphoma kinase proteins in growth control and cancer. *J Cell Physiol* 199, 330-358, 2004.

Schaerer-Brodbeck, C. and A. Barberis, Coupling homologous recombination with growth selection in yeast: a tool for construction of random DNA sequence libraries. *Biotechniques*, 37(2): p. 202-206, 2004.

Stoica GE. et al. Identification of anaplastic lymphoma kinase as a receptor for the growth factor pleiotrophin. *The Journal of Biological Chemistry* 276(20), 16772-16779, 2001.

Stoica GE. et al. Midkine binds to anaplastic lymphoma kinase (ALK) and acts as a growth factor for different cell types. *The Journal of Biological Chemistry* 277 (39), 35990-35998, 2002.

Weber D. et al. Pleiotrophin can be rate-limiting for pancreatic cancer cell growth. *Cancer Research* 60, 5284-5288, 2000.

Wellstein et al., A Heparin-binding Growth Factor Secreted from Breast Cancer Cells Homologous to a Developmentally Regulated Cytokine. *JBC Vol 267*, p2582, 1992.

SWISSPROT: www.expasy.org

[www.emedicine.com/med/topic2692,htm](http://www.emedicine.com/med/topic2692.htm)

(glioblastoma)

www.emedicine.com/MED/topic3205.htm (ALCL)

Claims

1. An antibody which binds the human ALK protein, said antibody comprising a variable heavy chain CDR3 of a sequence with at least 50% sequence identity, preferably at least 60%, 70%, 75%, 85%, more preferably at least 90%, to the sequence SEQ. ID. No. 2.

2. The antibody of claim 1 comprising a variable heavy chain CDR3 of the sequence SEQ. ID. No. 2.

3. The antibody of claim 1 or 2, wherein binding the human ALK protein is specific.

4. The antibody of anyone of the preceding claims which is an antibody fragment, scFv antibody or a Fab fragment.

5. The antibody of anyone of the preceding claims which is an scFv antibody.

6. The antibody of anyone of the preceding claims comprising a H3 VH domain and a lambda1 VL domain.

7. The antibody of anyone of the preceding claims, wherein the framework of VH and VL is stable and soluble so as to be functional in an intracellular reducing environment.

8. The antibody of anyone of the preceding claims comprising the framework 4.4.

9. The antibody of anyone of the preceding claims, said antibody binding a 16-amino acid ALK epitope peptide of a sequence of at least 75% sequence identity to the sequence SEQ. ID. No. 1.

10. The antibody of claim 9, wherein the ALK epitope peptide has the sequence SEQ. ID. No 1.

11. The antibody of claim 9 or 10, whose affinity for the ALK epitope peptide is characterized by a K_d of 30 nM or less, preferably 10 nM or less, most preferably below 3 nM.

12. The antibody of anyone of the preceding claims comprising a variable light chain CDR3 of a sequence with at least 50% sequence identity, preferably at least 60%, 70%, 80%, 85%, or more preferably at least 90%, to the sequence SEQ.ID, No. 3.

13. The antibody of anyone of the preceding claims comprising a variable light chain CDR3 of the sequence SEQ. ID. No. 3.

14. The antibody of anyone of the preceding claims, which binds a 16-amino-acid ALK epitope peptide of a sequence with at least 75% , preferably 100%, amino acid identity to the sequence SEQ.ID. No. 1.

15. The antibody of anyone of the preceding claims whose affinity for the ALK epitope peptide is given by a K_d of less than 10 nM, preferably less than 7 nM.

16. The antibody of anyone of the preceding claims, said antibody comprising a VH sequence of SEQ.ID. No. 4 and a VL sequence of SEQ.ID. No. 5.

17. The antibody of anyone of the preceding claims comprising at least one mutation in at least one of the CDRs resulting in a higher affinity characterized by a K_D of less than about 3 nM.

18. The antibody of claim 17, wherein said mutation is in CDR1 or CDR2 of VH and/or VL.

19. The antibody of claim 17, wherein said mutation or said mutations are in CDR2 of VH.

20. The antibody of anyone of the preceding claims comprising a variable heavy chain CDR2 comprising a sequence selected from the group of SEQ. ID. No. 7, SEQ.ID. No. 8, SEQ.ID. No. 9, SEQ.ID. No. 10, SEQ.ID. No. 11, SEQ.ID. No. 12, or SEQ.ID. No. 13.

21. The antibody of claim 20 wherein said defined sequences of CDR2 are preceded by the amino acids residues AI and followed by the sequences of SEQ.ID. No. 17.

22. The antibody of anyone of the preceding claims, said antibody comprising a VH sequence of SEQ.ID. No. 14 and a VL sequence of SEQ.ID. No. 15.

23. The antibody of anyone of claims 5 to 22, said antibody comprising the structure NH₂-VL-linker-VH-

COOH or NH₂-VH-linker-VL-COOH, wherein the linker has the sequence SEQ.ID. No. 16.

24. The antibody of anyone of the preceding claims, said antibody being radiolabeled or toxin-labeled.

25. The antibody of anyone of the preceding claims as a medicament or a diagnostic tool.

26. The use of the antibody of anyone of the preceding claims for the production of a medicament for the treatment of cancers or tumors.

27. The use according to claim 26, wherein the medicament is suitable the inhibition of MK and/or PTN binding to ALK and/or ALK-mediated signaling.

28. The use of claim 26 or 27, wherein the medicament is a combined medicament suitable for administering said antibody in combination with an anticancer agent, e.g., methotrexate.

29. The use of claim 26, wherein the treatment is a treatment of neuroblastoma, glioblastoma, rhabdomyosarcoma, breast carcinoma, melanoma, pancreatic cancer, B-cell NHL, thyroid carcinoma, small cell lung carcinoma, retinoblastoma, ewing sarcoma, prostate cancer, colon cancer, pancreatic cancer, lipoma, liposarcoma, fibrosarcoma, in particular glioblastoma, neuroblastoma and rhabdomyosarcoma.

30. A DNA sequence encoding the antibody of anyone of claims 1 to 23.

31. An expression vector comprising the DNA sequence of claim 30.

32. A suitable host cell transformed with an expression vector of claim 31, in particular an *E. coli* cell.

33. A method for the production of an antibody of anyone of claims 1 to 23 comprising culturing the host cell of claim 32 under conditions that allow the synthesis of said antibody and recovering it from said culture.

34. An ALK vaccine comprising an isolated ALK protein or a fragment thereof, or a nucleic acid encoding an epitope of ALK.

35. The vaccine of claim 34, wherein the vaccine comprises residues 391-406 of an isolated ALK protein.

36. The vaccine of claims 34 or 35, wherein the vaccine consists of residues 391-406 of an isolated ALK protein formulated with a carrier, adjuvant, and/or hapten to enhance the immune response to the ALK protein or fragment thereof.

37. An antibody or antigen binding fragment thereof that is capable of specifically binding residues of the region spanning amino acid residues 391 ± 3 and

406 ± 3 (SEQ. ID. No: 91), most preferably amino acids 391-406 (SEQ. ID. No: 1), of an isolated ALK protein or fragment thereof.

38. The antibody of claim 37, wherein the antibody is a single chain antibody (scFv), Fab fragment, IgG, or IgM.

39. An ALK epitope suitable for identifying, screening, or raising anti-ALK antibodies or fragments thereof, wherein the ALK epitope is a fragment of, comprises or consists essentially of the region spanning amino acid residues 391 ± 3 and 406 ± 3 (SEQ. ID No: 91), most preferably amino acids 391-406 (SEQ. ID.No: 1).

40. The antibody of anyone of claims 1 to 8, said antibody binding an epitope being a fragment of, comprises or consists essentially of the region spanning amino acid residues 391 ± 3 and 406 ± 3 (SEQ. ID No: 91), most preferably amino acids 391-406 (SEQ. ID.No: 1).

Fig. 1

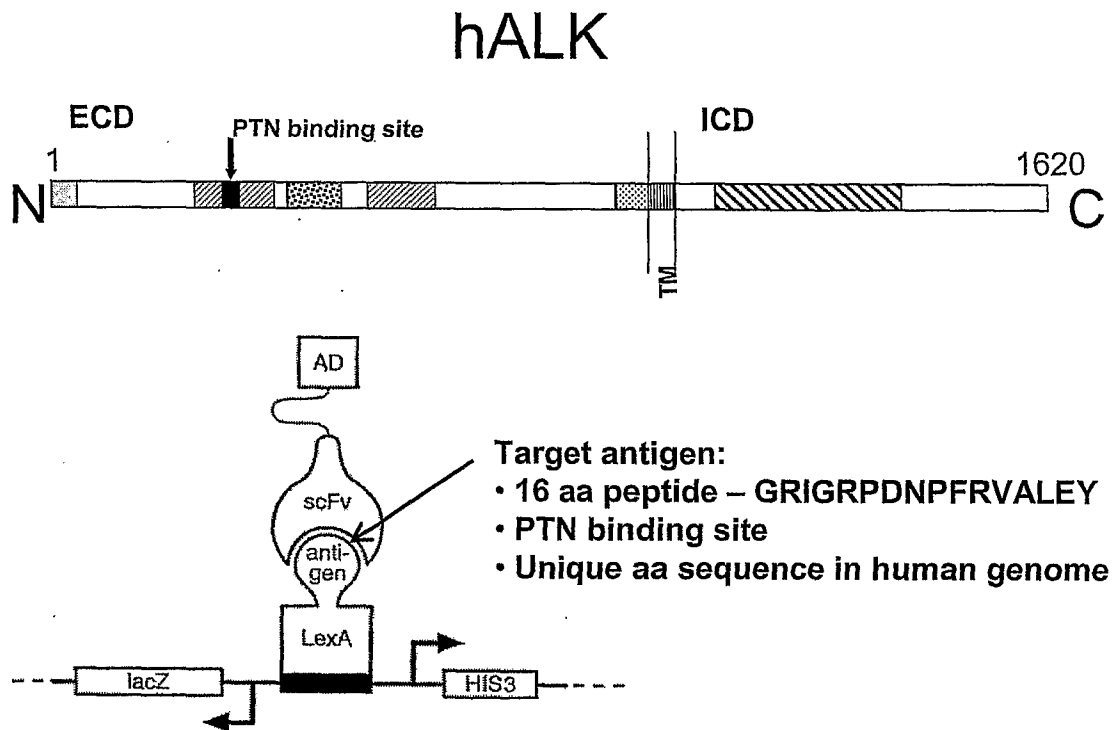

2/5

Fig. 2

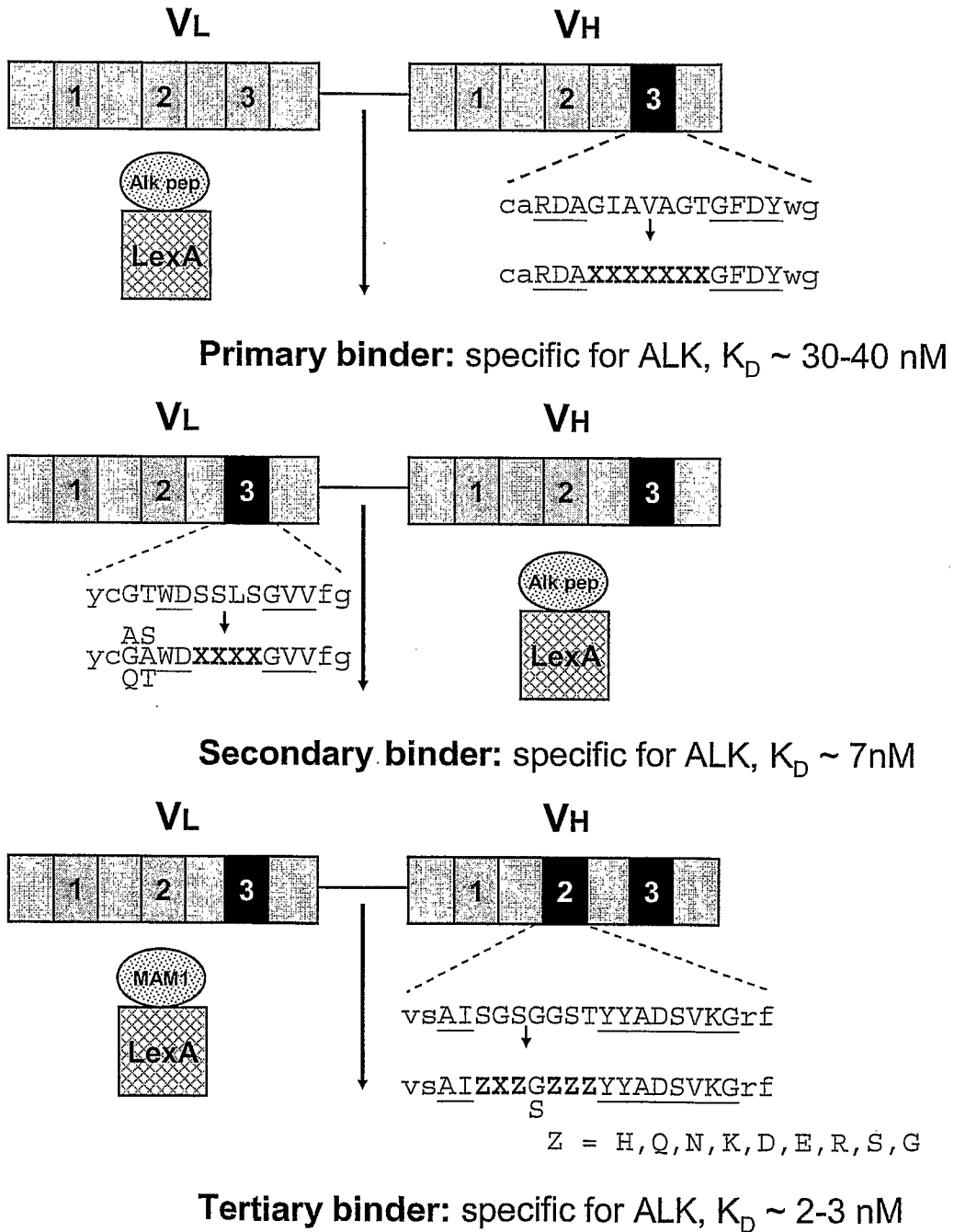

3/5

Fig. 3

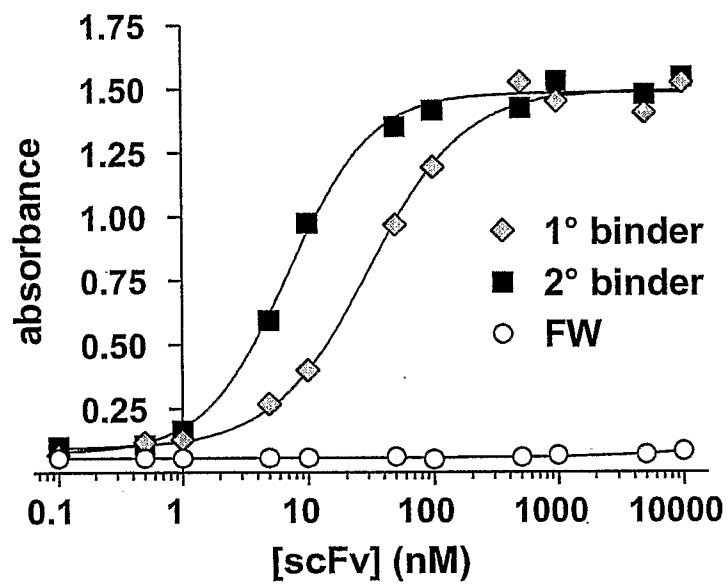

ELISA: GST-ALK peptide

 K_d 1° binder: 31.0 ± 1.3 nM2° binder: 7.2 ± 1.4 nM \rightarrow ESBA521

4/5

Fig. 4

Human ALK

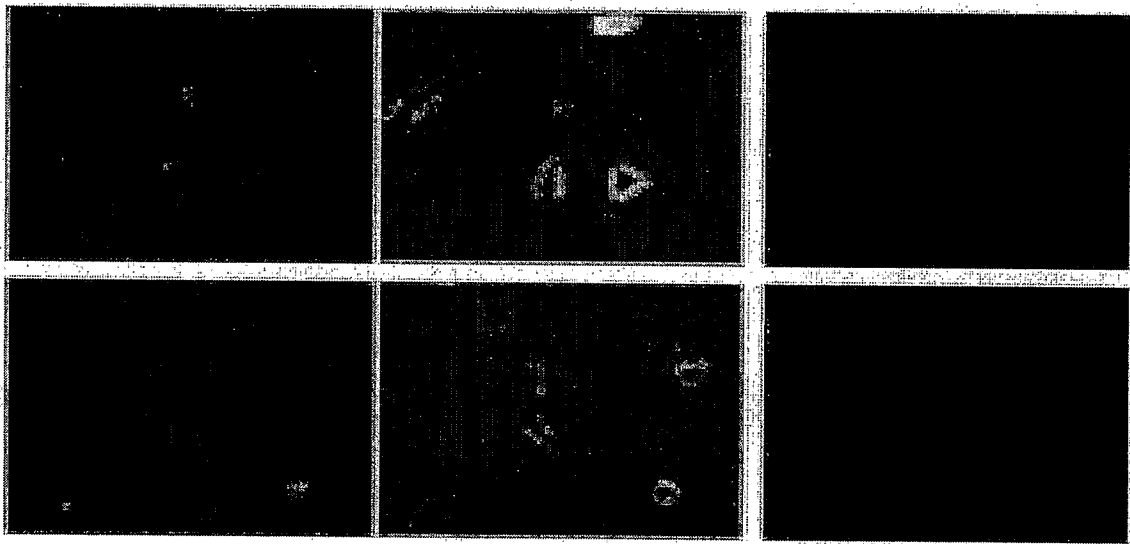

ESBA521

polyclonal AB

Fig. 5

5/5

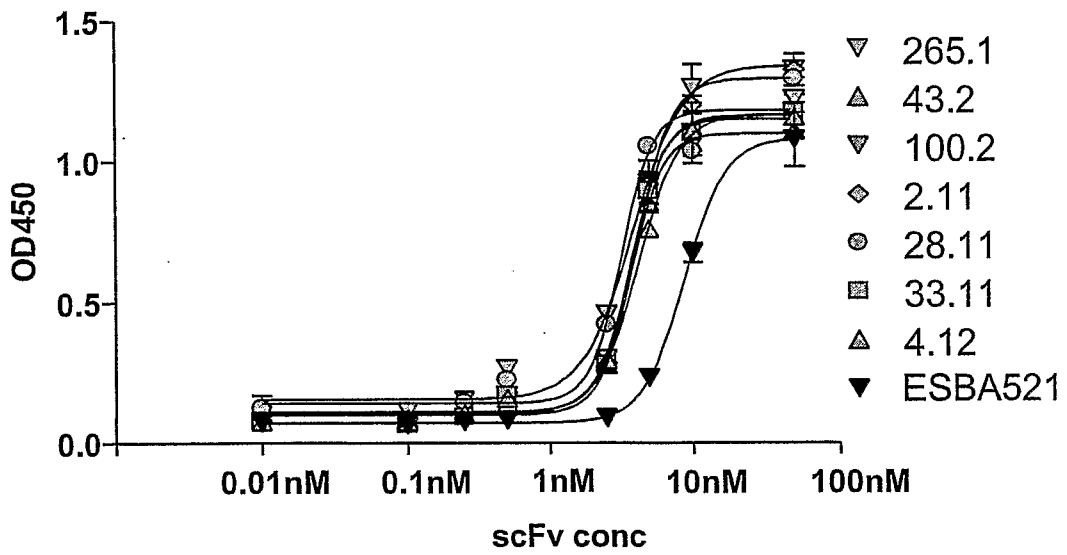

INTERNATIONAL SEARCH REPORT

International application No
PCT/CH2007/000202A. CLASSIFICATION OF SUBJECT MATTER
INV. C07K16/28 A61K39/00 A61P39/00

According to International Patent Classification (IPC) or to both national classification and IPC

B. FIELDS SEARCHED

Minimum documentation searched (classification system followed by classification symbols)
C07K A61K A61P

Documentation searched other than minimum documentation to the extent that such documents are included in the fields searched

Electronic data base consulted during the international search (name of data base and, where practical, search terms used)

EPO-Internal, BIOSIS, EMBASE, SCISEARCH, WPI Data

C. DOCUMENTS CONSIDERED TO BE RELEVANT

Category*	Citation of document, with indication, where appropriate, of the relevant passages	Relevant to claim No.
X	STOICA G E ET AL: "Identification of anaplastic lymphoma kinase as a receptor for the growth factor pleiotrophin" JOURNAL OF BIOLOGICAL CHEMISTRY, AMERICAN SOCIETY OF BIOCHEMICAL BIOLOGISTS, BIRMINGHAM,, US, vol. 276, no. 20, 18 May 2001 (2001-05-18), pages 16772-16779, XP002222815 ISSN: 0021-9258 page 16774 page 16778 ----- -/--	1-40

 Further documents are listed in the continuation of Box C. See patent family annex.

* Special categories of cited documents :

- *A* document defining the general state of the art which is not considered to be of particular relevance
- *E* earlier document but published on or after the international filing date
- *L* document which may throw doubts on priority claim(s) or which is cited to establish the publication date of another citation or other special reason (as specified)
- *O* document referring to an oral disclosure, use, exhibition or other means
- *P* document published prior to the international filing date but later than the priority date claimed

- *T* later document published after the international filing date or priority date and not in conflict with the application but cited to understand the principle or theory underlying the invention
- *X* document of particular relevance; the claimed invention cannot be considered novel or cannot be considered to involve an inventive step when the document is taken alone
- *Y* document of particular relevance; the claimed invention cannot be considered to involve an inventive step when the document is combined with one or more other such documents, such combination being obvious to a person skilled in the art.
- *Z* document member of the same patent family

Date of the actual completion of the international search

27 September 2007

Date of mailing of the international search report

19/10/2007

Name and mailing address of the ISA/

European Patent Office, P.B. 5818 Patentlaan 2
NL - 2280 HV Rijswijk
Tel. (+31-70) 340-2040, Tx. 31 651 epo nl,
Fax: (+31-70) 340-3016

Authorized officer

Domingues, Helena

INTERNATIONAL SEARCH REPORT

International application No

PCT/CH2007/000202

C(Continuation). DOCUMENTS CONSIDERED TO BE RELEVANT

Category*	Citation of document, with indication, where appropriate, of the relevant passages	Relevant to claim No.
X	<p>STOICA GERALD E ET AL: "Midkine binds to anaplastic lymphoma kinase (ALK) and acts as a growth factor for different cell types"</p> <p>JOURNAL OF BIOLOGICAL CHEMISTRY, AMERICAN SOCIETY OF BIOLOCHEMICAL BIOLOGISTS, BIRMINGHAM,, US, vol. 277, no. 39, 27 September 2002 (2002-09-27), pages 35990-35998, XP002290577 ISSN: 0021-9258 page 35991 figure 3 page 35997</p>	1-40
Y	<p>-----</p> <p>US 2001/021505 A1 (MORRIS STEPHAN W [US] ET AL MORRIS STEPHAN W [US] ET AL) 13 September 2001 (2001-09-13) column 8, paragraph 183; example 2</p>	1-40
Y	<p>-----</p> <p>AUF DER MAUR A ET AL: "Antigen-independent selection of intracellular stable antibody frameworks" METHODS : A COMPANION TO METHODS IN ENZYMOLOGY, ACADEMIC PRESS INC., NEW YORK, NY, US, vol. 34, no. 2, October 2004 (2004-10), pages 215-224, XP004526807 ISSN: 1046-2023 the whole document</p>	1-40
Y	<p>-----</p> <p>AUF DER MAUR A ET AL: "Direct in vivo screening of intrabody libraries constructed on a highly stable single-chain framework" JOURNAL OF BIOLOGICAL CHEMISTRY, AMERICAN SOCIETY OF BIOLOCHEMICAL BIOLOGISTS, BIRMINGHAM,, US, vol. 277, no. 47, 22 November 2002 (2002-11-22), pages 45075-45085, XP002284890 ISSN: 0021-9258 page 45075; figure 1 pages 45080-1</p>	1-40
Y	<p>-----</p> <p>EP 1 479 694 A (ESBATECH AG [CH]) 24 November 2004 (2004-11-24) the whole document</p>	1-40
Y	<p>-----</p> <p>WO 03/097697 A (ESBATECH AG [CH]; TISSOT KATHRIN [CH]; EWERT STEFAN [CH]; AUF DER MAUR) 27 November 2003 (2003-11-27) page 21; claim 6; examples 3,4; sequences 4,11</p> <p>-----</p>	1-40

INTERNATIONAL SEARCH REPORT

International application No.
PCT/CH2007/000202

Box II Observations where certain claims were found unsearchable (Continuation of item 2 of first sheet)

This International Search Report has not been established in respect of certain claims under Article 17(2)(a) for the following reasons:

1. Claims Nos.:
because they relate to subject matter not required to be searched by this Authority, namely:

2. Claims Nos.:
because they relate to parts of the International Application that do not comply with the prescribed requirements to such an extent that no meaningful International Search can be carried out, specifically:

3. Claims Nos.:
because they are dependent claims and are not drafted in accordance with the second and third sentences of Rule 6.4(a).

Box III Observations where unity of invention is lacking (Continuation of item 3 of first sheet)

This International Searching Authority found multiple inventions in this international application, as follows:

see additional sheet

1. As all required additional search fees were timely paid by the applicant, this International Search Report covers all searchable claims.
2. As all searchable claims could be searched without effort justifying an additional fee, this Authority did not invite payment of any additional fee.
3. As only some of the required additional search fees were timely paid by the applicant, this International Search Report covers only those claims for which fees were paid, specifically claims Nos.:
4. No required additional search fees were timely paid by the applicant. Consequently, this International Search Report is restricted to the invention first mentioned in the claims; it is covered by claims Nos.:

Remark on Protest

- The additional search fees were accompanied by the applicant's protest.
- No protest accompanied the payment of additional search fees.

FURTHER INFORMATION CONTINUED FROM PCT/ISA/ 210

This International Searching Authority found multiple (groups of) inventions in this international application, as follows:

1. claims: 1-33, 37, 38 and 40

Concerns aspects linked to an antibody which binds human ALK protein; particularly to the region spanning amino acid residues 391-406; a method for the production of said antibody and its use to inhibit MK and/or PTN binding to ALK and/or ALK mediated signalling.

2. claims: 34-36 and 39

Concerns an ALK epitope comprising or consisting essentially of the region spanning amino acid residues 391-406 and a vaccine comprising an isolated ALK protein or fragment thereof, particularly the fragment just mentioned.

INTERNATIONAL SEARCH REPORT

Information on patent family members

International application No

PCT/CH2007/000202

Patent document cited in search report		Publication date	Patent family member(s)	Publication date
US 2001021505	A1	13-09-2001	NONE	
EP 1479694	A	24-11-2004	DK 1242457 T3	20-12-2004
WO 03097697	A	27-11-2003	AU 2003238370 A1	02-12-2003
			CA 2483285 A1	27-11-2003
			CN 1662556 A	31-08-2005
			EP 1506236 A2	16-02-2005
			JP 2006508638 T	16-03-2006