



US00D738247S

(12) **United States Design Patent**  
**Dobbs**

(10) **Patent No.:** **US D738,247 S**

(45) **Date of Patent:** **\*\* Sep. 8, 2015**

(54) **ROADWAY MARKER**

(71) Applicant: **Blaine Alan Dobbs**, Sugar Land, TX  
(US)

(72) Inventor: **Blaine Alan Dobbs**, Sugar Land, TX  
(US)

(\*\*) Term: **14 Years**

(21) Appl. No.: **29/491,007**

(22) Filed: **May 15, 2014**

(51) **LOC (10) CL.** ..... **10-05**

(52) **U.S. CL.**  
USPC ..... **D10/113.1**

(58) **Field of Classification Search**  
USPC ..... D10/111, 113.1, 113.4, 109.1,  
D10/114.1–114.2, 114.4, 70; D26/97, 91,  
D26/28, 37  
CPC ..... F21V 7/00  
See application file for complete search history.

(56) **References Cited**

**U.S. PATENT DOCUMENTS**

D181,699 S *	12/1957	Abbott	.....	D10/113.1
D263,287 S *	3/1982	Maxeiner	.....	D10/111
D421,726 S *	3/2000	Yang et al.	.....	D10/111
D681,494 S *	5/2013	Beghelli	.....	D10/114.2

**OTHER PUBLICATIONS**

U.S. Appl. No. 61/994,013; Roadway Delineator and Safety Systems; Blaine Alan Dobbs; filed May 15, 2014.

\* cited by examiner

*Primary Examiner* — George D Kirschbaum  
(74) *Attorney, Agent, or Firm* — Finnegan, Henderson, Farabow, Garrett & Dunner, LLP

(57) **CLAIM**

The ornamental design for a roadway marker, as shown and described.

**DESCRIPTION**

FIG. 1 is a front right perspective view of a first embodiment of a roadway marker showing my new design; FIG. 2 is a front elevation view thereof, the rear elevation view being identical thereto; FIG. 3 is a left side view thereof, the right side view being identical thereto; FIG. 4 is a top plan view thereof; FIG. 5 is a front right perspective view of the second embodiment of a roadway marker showing my new design; FIG. 6 is a front elevation view thereof, the rear elevation view being identical thereto; FIG. 7 is a left side view thereof, the right side being identical thereto; and, FIG. 8 is a top plan view thereof. The broken lines shown in the drawings illustrate portions of the roadway marker that form no part of the claimed design. The bottom view of the roadway marker is not visible during ordinary use and forms no part of the claimed design.

**1 Claim, 8 Drawing Sheets**

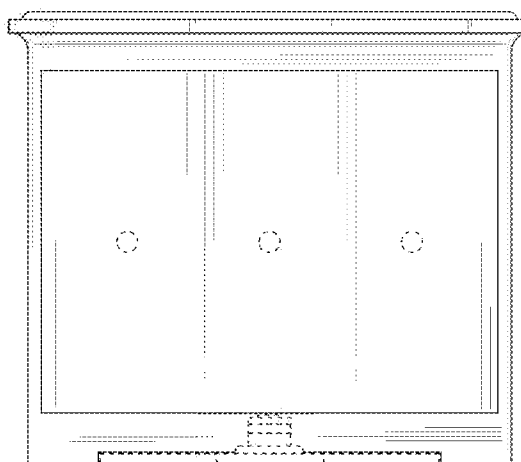
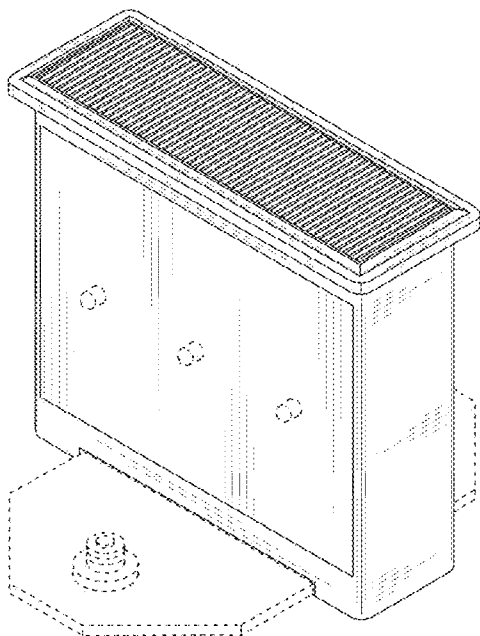

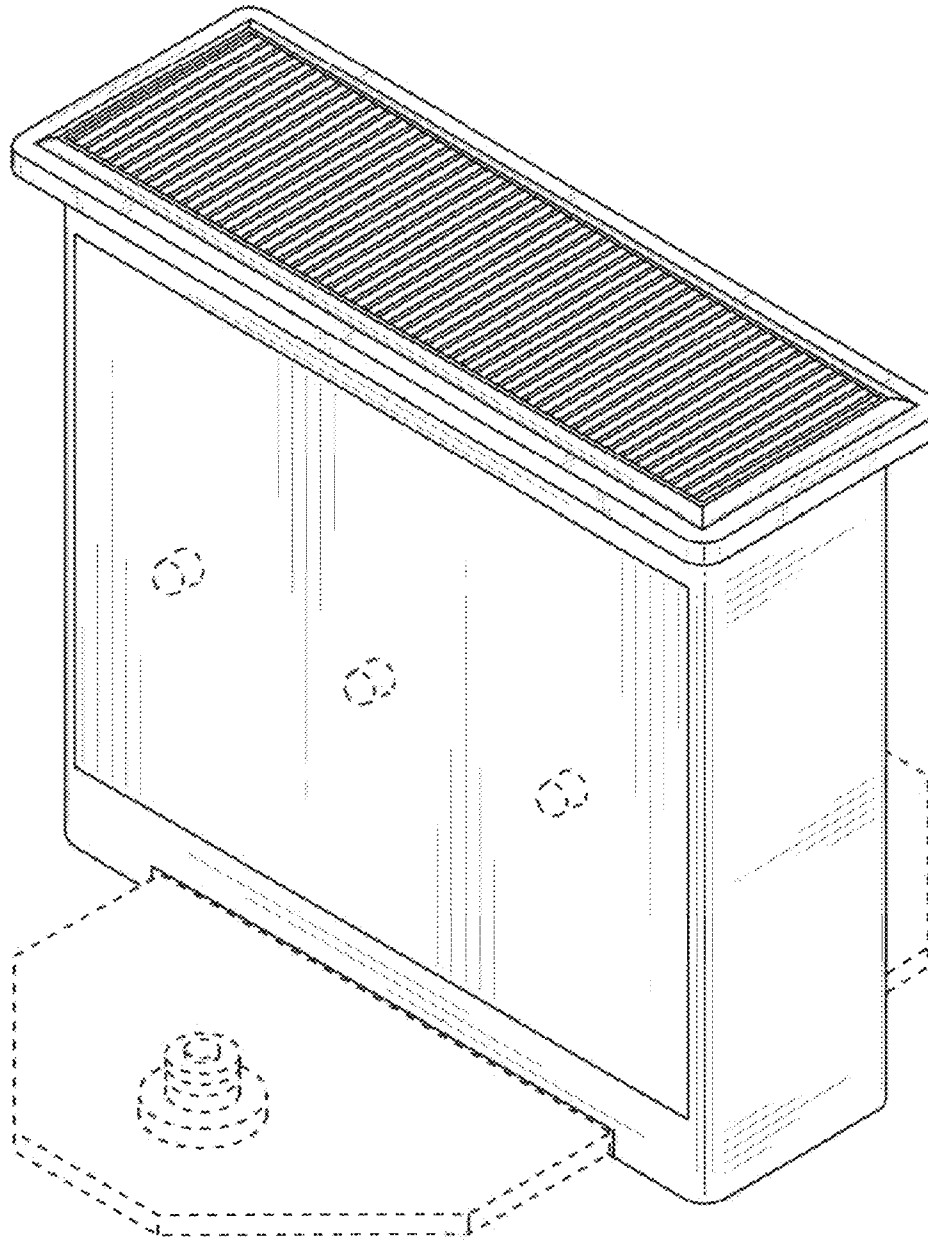

**FIG. 1**

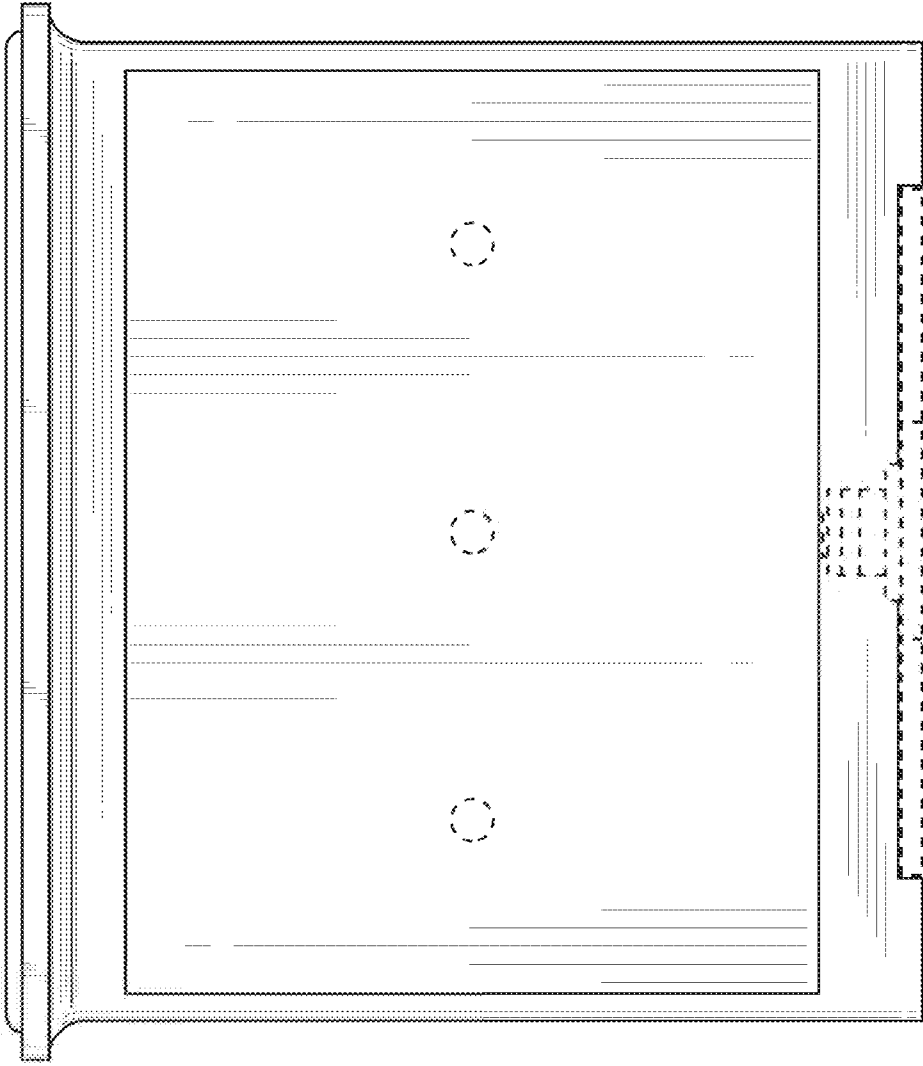

FIG. 2

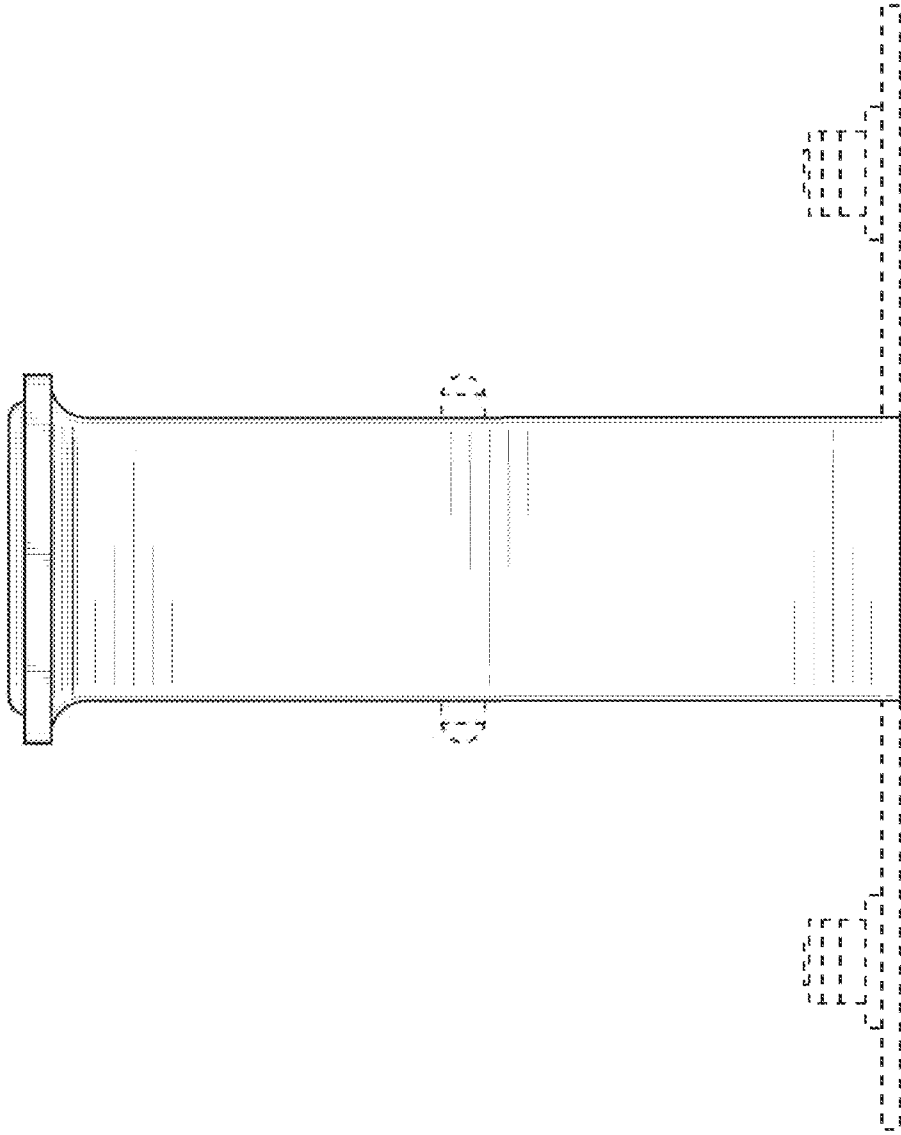
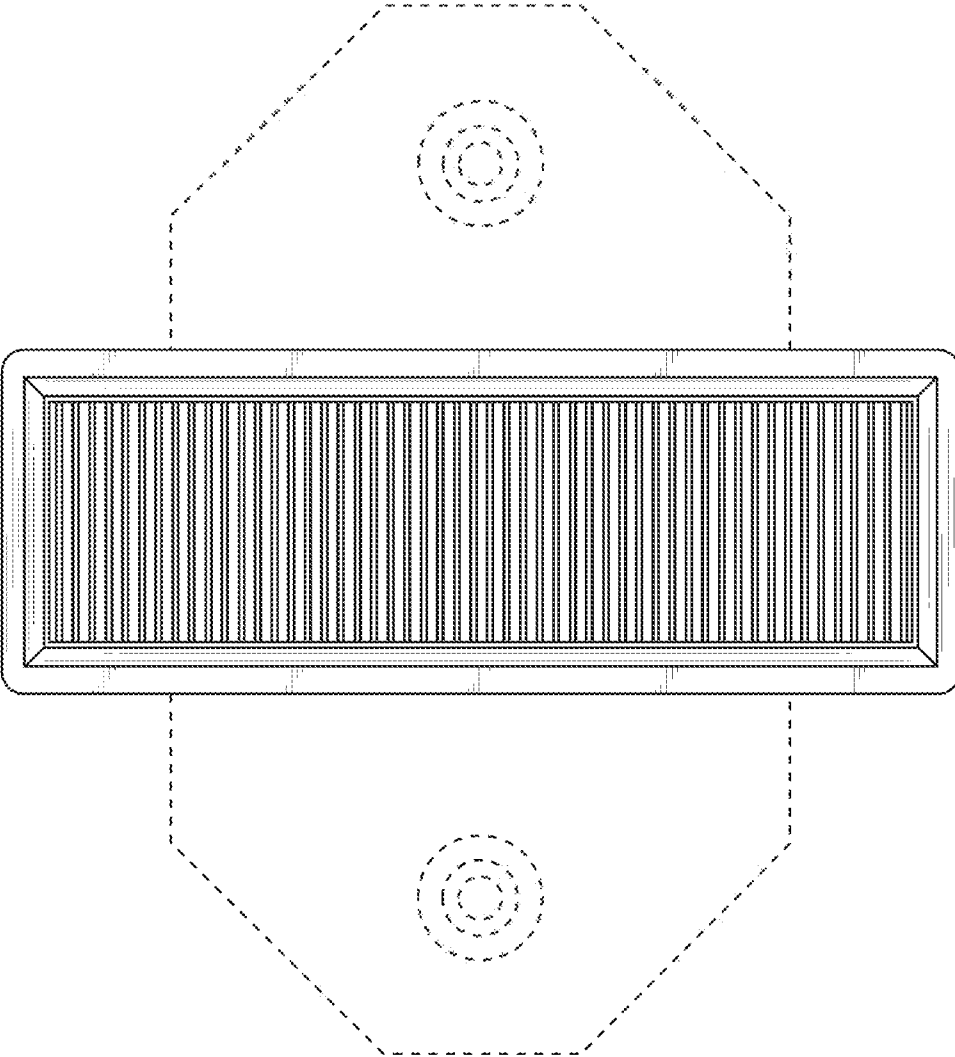
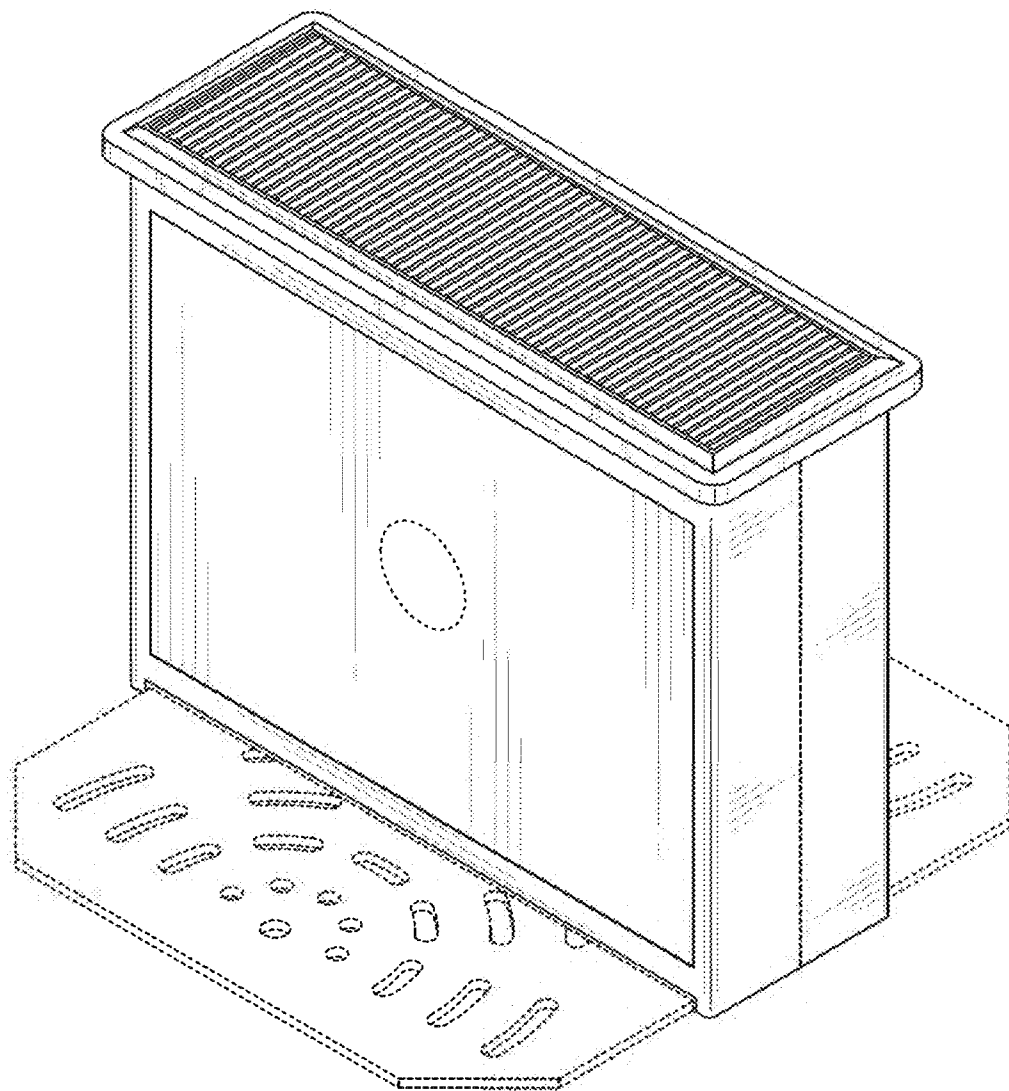

FIG. 3



**FIG. 4**



**FIG. 5**

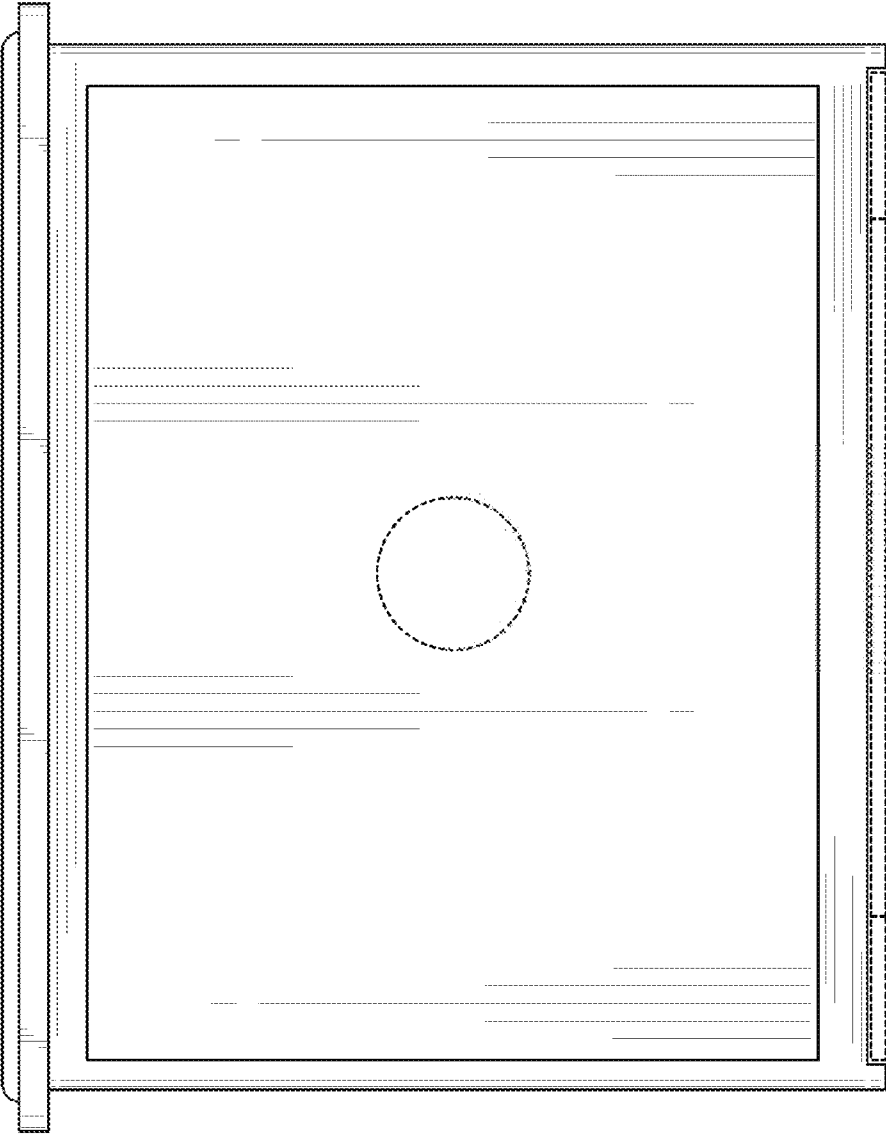

**FIG. 6**

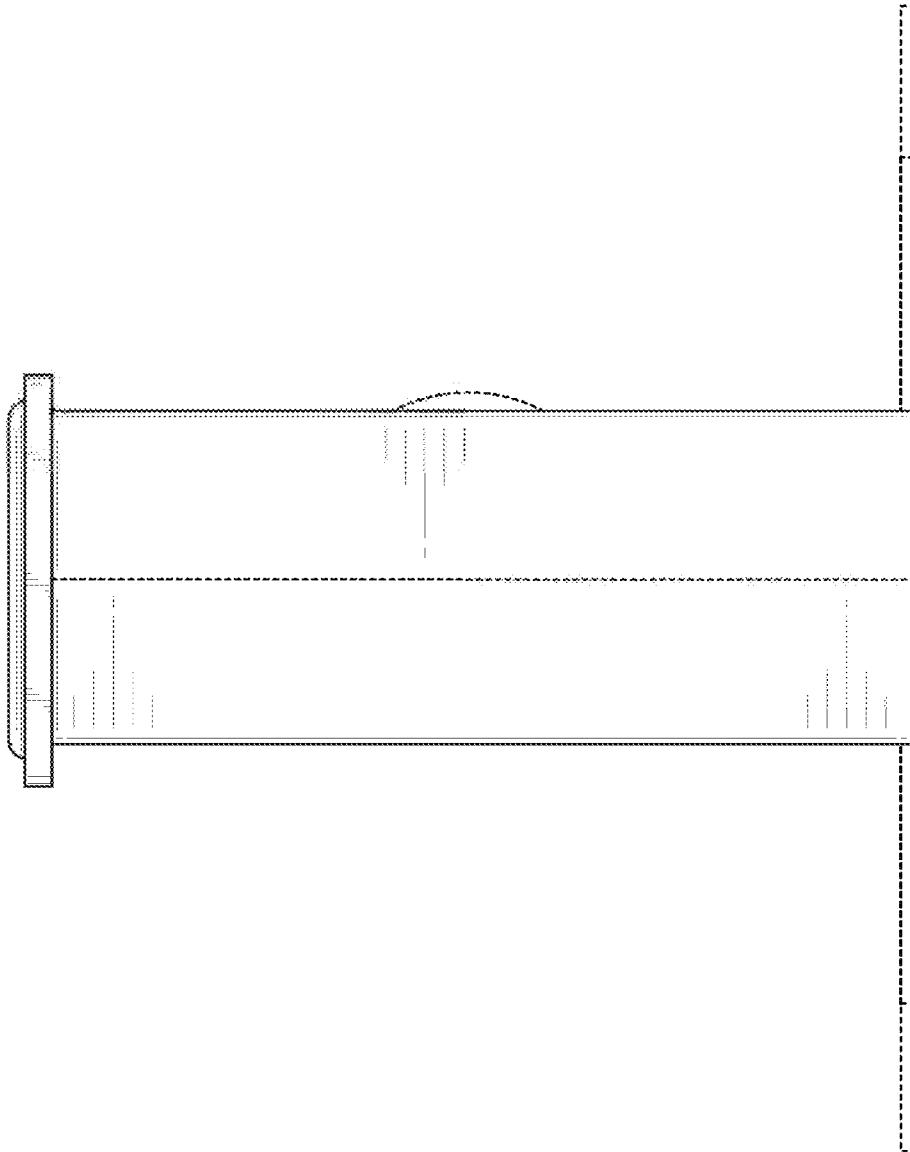

**FIG. 7**

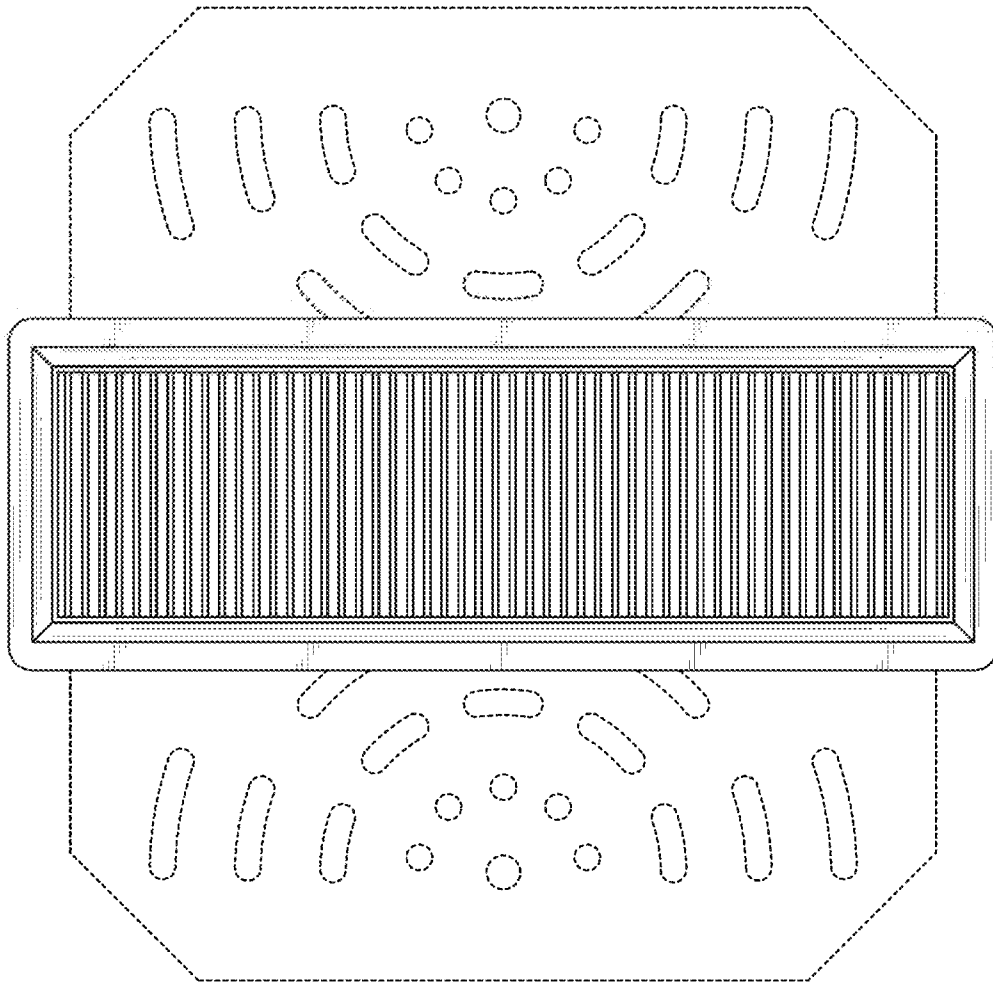

**FIG. 8**