

(19)



(11)

EP 4 353 577 B1

(12)

EUROPEAN PATENT SPECIFICATION

(45) Date of publication and mention of the grant of the patent:
19.02.2025 Bulletin 2025/08

(21) Application number: **22754909.4**

(22) Date of filing: **10.06.2022**

(51) International Patent Classification (IPC):
B63B 1/04 (2006.01)

(52) Cooperative Patent Classification (CPC):
**B63B 21/16; B63B 1/041; B63B 1/048;
B63B 21/10; B63B 21/502; B63B 39/00;
B63B 43/04; B63B 43/08; B63B 2001/044;
B63B 2035/442; B63B 2035/446**

(86) International application number:
PCT/IB2022/000334

(87) International publication number:
WO 2022/259042 (15.12.2022 Gazette 2022/50)

(54) **MOORING SYSTEM AND METHOD FOR INSTALLING A FLOATING PLATFORM USING SAID MOORING SYSTEM**

VERANKERUNGSSYSTEM UND VERFAHREN ZUR INSTALLATION EINER SCHWIMMENDEN PLATFORM UNTER VERWENDUNG DIESES VERANKERUNGSSYSTEMS

SYSTÈME DE MOUILLAGE ET PROCÉDÉ D'INSTALLATION D'UNE PLATEFORME FLOTTANT UTILISANT CE SYSTÈME DE MOUILLAGE

(84) Designated Contracting States:
**AL AT BE BG CH CY CZ DE DK EE ES FI FR GB
GR HR HU IE IS IT LI LT LU LV MC MK MT NL NO
PL PT RO RS SE SI SK SM TR**

(30) Priority: **10.06.2021 ES 202130534**

(43) Date of publication of application:
17.04.2024 Bulletin 2024/16

(73) Proprietor: **GAZELLE WIND POWER LIMITED
D04 TR29 (IE)**

(72) Inventor: **GARCÍA FERRÁNDEZ, Antonio Luís
28224 Madrid (ES)**

(74) Representative: **Elzaburu S.L.P.
Edificio Torre de Cristal
Paseo de la Castellana 259 C, planta 28
28046 Madrid (ES)**

(56) References cited:
**ES-A2- 2 629 867 US-A- 5 107 784
US-A1- 2018 148 140**

EP 4 353 577 B1

Note: Within nine months of the publication of the mention of the grant of the European patent in the European Patent Bulletin, any person may give notice to the European Patent Office of opposition to that patent, in accordance with the Implementing Regulations. Notice of opposition shall not be deemed to have been filed until the opposition fee has been paid. (Art. 99(1) European Patent Convention).

Description

Object of the invention

5 **[0001]** The present invention relates to an anchoring system especially suitable for floating platforms that serve as a base for wind turbines located in the sea. The anchoring system object of the present invention comprises a set of anchoring cables or chains (anchoring lines) fastened to piles buried in the seabed or to weights located or deposited on the seabed.

10 **[0002]** The anchoring system object of the present invention has unique characteristics that make it suitable to be used on floating platforms that serve as a basis for maritime structures where it is important to avoid pitching or rolling movement, as well as solving some drawbacks of other anchoring systems for floating platforms of the state of the art.

[0003] The present invention also relates to a method of installing a floating platform using said anchoring system.

15 **[0004]** The anchoring system object of the present invention is applicable to any type of structure intended to be located floating on the surface of the sea, and which needs to have several anchoring points on the seabed, to fasten the cables or anchoring chains of the floating platforms.

Background of the invention and technical problem to be solved

20 **[0005]** Floating platforms, especially those dedicated to supporting wind turbines for the generation of electrical energy from offshore wind energy, need anchoring systems that keep them in their position and contribute to their stability.

[0006] In the state of the art, platforms of the Tension Leg Platform (TLP) type are known. These platforms comprise three or more anchoring lines (usually chains or cables that connect the platform with piles anchored to the seabed). The anchoring lines of TLP platforms are designed to be disposed in tension, connecting the platform in an upright position to each of the piles anchored on the seabed. TLP platforms comprise a set of floats designed to produce an excess buoyancy of the platform (taking into account the weight of the structure that sits on the platform). This excess buoyancy ensures a high level of tension in the cables, which in turn ensures that they are always upright. In this way, the pitching and rolling movements of the platform and the structure that sits on the platform are avoided.

25 **[0007]** EP 2743170 A1 describes a TLP platform as described in the previous paragraph.

[0008] A disadvantage of TLP platforms is that the high tension of the cables necessary to keep them in vertical position and thus avoid pitching and/or rolling movements also results in blocking movement in the vertical direction of the platform. Thus, when the tide rises, the platform cannot move upwards (due to the fact that the anchoring lines have reduced or no extensibility) and, therefore, the tension in the anchoring lines increases considerably. This causes a high risk of breakage of the anchoring lines and requires having high-section anchoring lines or increasing the number of anchoring lines.

30 **[0009]** Additionally, in TLP platforms, in very low tide situations, the platform also descends and the anchoring lines can lose much of their tension, increasing the risk that the platform moves both vertically and laterally in an uncontrolled manner, and also increasing the risk that pitching and/or rolling movements occur (due to the thrust of the wind and/or waves on the platform and the structure that sits on it) that can result in the overturning of the platform.

35 **[0009]** To avoid the aforementioned drawbacks, other types of floating platforms are known where the anchoring lines are connected to a counterweight through pulleys located on the platform. These types of platforms allow the vertical and lateral displacement of the platform in the face of tides, waves and wind, thus making it unnecessary to have a large number of anchoring lines or anchoring lines of a high section.

40 **[0010]** Document ES 2629867 A2 describes a platform as described in the previous paragraph.

[0011] An existing problem with the anchoring system described in the document mentioned in the previous paragraph is that floating platforms that use said anchoring system are subjected to pitching and/or rolling movements that can become important, which make the anchoring system described in said document not the most suitable for:

45

- applications where there are persons likely to become seasick with the movements of the platform (i.e. other than marine professionals), such as young children, tourists, scientists, guests and visitors in general;

50

- floating platforms on which offshore marine wind turbines are installed, where it is important to avoid rolling and/or excessive pitching of the platform;
- applications in which the equipment installed and the activity to which it is dedicated (laboratories, research centers, factories) require that the movements and accelerations of the platform are small;

55

- floating platforms that may be subjected (at some point) to extremely severe storms, that could endanger the safety of the same structure or that may overturn it (if the pitching movements were very large).

Description of the invention

[0012] In order to remedy the aforementioned drawbacks, the present invention relates to a anchoring system.

[0013] The anchoring system object of the present invention comprises a floating platform (for example, to support a wind turbine) and at least one pair of anchoring lines (for example, anchoring cables or anchoring chains), configured to fix or anchor the floating platform to the seabed (for example to piles driven into the seabed, or to bottom weights or anchoring rings deposited on the seabed) by at least one bottom section of each anchoring line.

[0014] Each anchoring line also comprises a central section attached to a counterweight.

[0015] Each pair of anchoring lines comprises two anchoring lines arranged in a plane passing through a central axis of the floating platform. These anchoring lines arranged in the same plane are located respectively on either side of the central axis of the floating platform.

[0016] The central axis of the floating platform preferably defines a radial symmetry of the floating platform.

[0017] The anchoring system comprises at least one first rotary fixing means (e.g., a pulley) for each anchoring line, wherein each first rotary fixing means is fixed to a first point of the floating platform and is configured to fix each anchoring line to the floating platform at said first point of the floating platform, allowing sliding of the anchoring line on said first rotary fixing means.

[0018] As a novel feature, in the anchoring system object of the present invention:

- each anchoring line comprises at least one direct subline and one cross subline. These sublines are chains or cables that run in parallel, at least in their bottom section. Each direct subline runs from the first rotary fastening means to the counterweight without passing through the central axis of the floating platform. Each cross subline runs from the first rotary fastening means to the counterweight through the central axis of the floating platform. The first rotary fastening means may, for example, be formed by a pulley with two sheaves (for the passage/sliding of the two anchoring sublines), or by a set of two pulleys.

- The system comprises at least one second rotary fixing means (e.g., a pulley) for each anchoring line, wherein each second rotary fixing means is fixed to a second point of the floating platform and is configured to fix each cross subline of each anchoring line to the floating platform at said second point of the floating platform, allowing the cross subline to slide on said second rotary fixing means, such that each cross subline runs from the first rotary fixing means to the counterweight first through the central axis of the floating platform and secondly sliding on the second rotary fixing means.

[0019] By means of the anchoring system described above, the pitch and/or roll of the floating platform is cancelled or drastically reduced with respect to other anchoring systems such as that described in document ES 2629867 A2, while leaving the floating platform free to move vertically, also allowing restricted horizontal movements.

[0020] By means of the anchoring system described above, the pulley system used in other anchoring systems by means of pulleys and cables in the state of the art is mechanically simplified. Since there are no central pulleys located in correspondence with the central axis of the floating platform, the anchoring system is simpler and, moreover, all the central pulleys of all the arms that make up the system do not coincide in almost the same point.

[0021] Additionally, by means of the anchoring system described above, the pendular movement characteristic of the central counterweight, induced by the horizontal movements of the platform due to the waves, is eliminated.

[0022] Likewise, by means of the anchoring system described above, the need to have a central well in the hull (main structure or central structure) of the platform is eliminated, which in the state of the art was necessary for the passage of the central sections of the anchoring lines (those that hold the central counterweight).

[0023] Preferably, the floating platform comprises a pair of projecting structural arms for each pair of anchoring lines. Thus, each pair of protruding structural arms comprises a first arm and a second arm located symmetrically with respect to the central axis of the floating platform. Each projecting structural arm is attached to a main structure (or hull) of the floating platform. Each projecting structural arm runs radially from a first end attached to the main structure of the floating platform to a second end projected to the outside of the floating platform. Thus, the at least one first rotary securing means is fixed to the floating platform in correspondence with the second end of the first arm, and the at least one second rotary securing means is fixed to the floating platform at a point located in correspondence with the second arm.

[0024] The main structure (or hull) of the floating platform may have a shape in the form of a cylindrical, conical or pyramidal shaft. Additionally, the anchoring system may comprise a plurality of spokes connected to this main structure, where at each free end of each spoke there is a flotation element. These flotation elements may comprise at least one flood chamber.

[0025] The main structure (or hull) of the floating platform may lack the aforementioned spokes with floating elements at their ends. However, the main structure or hull, with a shaft-shaped geometry, may comprise at least one flotation element. This at least one flotation element may comprise at least one floodable chamber.

[0026] The floating elements provide buoyancy and, when they are floodable, allow the floating platform to be moved or

towed to its place or site of installation, with a reduced weight and, subsequently, flood the corresponding floating elements to provide tension to the anchoring cables, increasing their stability.

[0027] When the flotation elements are located at the end of spokes attached to the shaft, the structure is particularly stable, and appropriate to guarantee the stability of the floating platform in the installation maneuver.

5 [0028] Alternatively to the shaft-shaped geometry, the main structure (or hull) of the floating platform may comprise a ring-shaped geometry, said ring being attached by means of spokes to a cylindrical, conical or pyramidal shaft. This main structure may constitute a flotation ring (a float or ring-shaped flotation element). This flotation ring may comprise at least one flood chamber.

[0029] This structure in the form of a floating ring also provides great stability to the floating platform.

10 [0030] The anchoring system may comprise at least one third rotary fastening means (e.g., a pulley) for each anchoring line. Each third rotary fixing means is fixed to a third point of the floating platform and is configured to fix each direct subline of each anchoring line to the floating platform at said third point of the floating platform allowing sliding of the direct subline by said third rotary fixing means, such that each direct subline runs from the first rotary fixing means to the counterweight passing and sliding by the third rotary fixing means.

15 [0031] This third rotary fixing means allows the direct subline to run in an intermediate section parallel to one of the protruding structural arms, so that the central section (which is directed from the third rotary fixing means to the counterweight) runs closer to the central axis of the floating platform.

[0032] Additionally, the anchoring system may comprise at least one rotary guiding means (e.g., a pulley or fluted wheel) for each anchoring line, wherein each rotary guiding means is fixed to a fourth point of the floating platform and is configured to guide the course of the cross subline of each anchoring line allowing the cross subline to slide by said rotary guiding means, such that each cross subline runs between the first rotary fixing means and the second rotary fixing means passing and sliding by the rotary guiding means.

20 [0033] This rotary guiding means allows the crossed sub-line to avoid obstacles in its path from the first rotary fixing means through the central axis to the second rotary fixing means. By means of this rotary guiding means, it is possible to prevent the crossed sublimes of all the anchoring lines from colliding with each other, or the crossed sublimes from colliding with the main structure of the floating platform.

25 [0034] Preferably, each bottom section of each anchoring line comprises a buoy that divides the bottom section into a first portion that runs between the seabed and the buoy and a second portion that runs between the buoy and the at least one first rotary fixing means.

30 [0035] The above feature facilitates the installation of the floating platform, since the bottom weight, pile or anchoring ring attached to a first portion of the bottom section (with the buoy) can be arranged in a pre-installation maneuver (once the location of the floating platform has been chosen) and, subsequently, connect the second portion of the bottom section directly to the buoy, when the floating platform and the counterweight have moved to the installation site.

35 [0036] Also preferably, the counterweight of the anchoring system comprises at least one floodable flotation chamber. This feature also facilitates the transport of the counterweight (which can be transported without flooding with less weight), and also facilitates a progressive contribution of tension to the anchoring lines, as the at least one floodable flotation chamber is filled.

[0037] The present invention also relates to a method of installing a floating platform, employing an anchoring system as described above.

40 [0038] Thus, the method of installing a floating platform object of the present invention comprises:

- positioning and/or anchoring to the seabed, under a place or installation site of the floating platform, at least one anchor and/or at least one bottom weight, and/or at least one anchoring ring and/or a set of piles;
- 45 - moving the floating platform and the counterweight to its place of installation, where the at least one flood chamber is located without flooding;
- fix a free end of the bottom section of each anchoring line:
 - 50 ◦ at least one anchor and/or at least one bottom weight, and/or at least one anchoring ring and/or the set of piles, or
 - to a buoy previously attached by a first portion of the bottom leg of the anchoring line to the at least one anchor and/or the at least one bottom weight, and/or the at least one anchoring ring and/or the set of piles;
- fixing a free end of the central section of each anchoring line to the counterweight;
- 55 - dragging the floating platform sideways until the anchoring lines are tensioned, and;
- flooding the at least one flotation chamber.

[0039] In the anchoring system of the present invention, the floating platform does not need to rest on the bottom, so it is suitable for areas of any sea depth, both near the coast (for example, 80 m deep), and away from it (up to depths of 1000 m or more) and at any intermediate distance, since it is able to withstand very severe storms.

[0040] In the preferred embodiments of the anchoring system of the invention, several platforms (for marine wind turbines) are presented that are intrinsically stable in all their possible states, from manufacture in port, to their final operating condition, through the transport to the wind farm and the assembly phases of the system cabling, flooding of the counterweight and final adjustments. Therefore, the installation process is much simpler and faster. No special ships are needed, just a small conventional tugboat.

[0041] The anchoring system of the invention makes it possible to uninstall and move the floating platform to another location, by means of a novel more simplified and faster procedure than that proposed in ES 2629867 A2.

[0042] The main features and advantages of the anchoring system of the invention are:

- It can be applied to any type of platform, especially for windmills and platforms dedicated to maritime leisure activities;
- It fully prevents the pitching and rolling movement of the platform, but allows horizontal or vertical movements;
- It does not need foundations, nor special preparation of the seabed (although conventional foundations can be used that are simpler than usual ones);
- The optimal draughts are between 50m and 400m, although it can reach greater depths;
- It can be installed or relocated (as many times as desired) without the need for special ships, using only a tugboat to move it;
- It can be adapted to capture wave energy by simply including one or more conventional generators;
- The forces that appear in the anchoring lines are much lower than on TLP platforms; if one anchoring line breaks, it still works with the others. In addition, it can be repaired / replaced on site;
- It allows designing platforms that are much lighter (and therefore cheaper) and with reduced strut (resulting in less visual impact);

[0043] The anchoring system of the invention is applicable to any floating marine installation, in which the movement requirements are an important condition of the design, especially in the following cases:

- Tourism, maritime leisure and nautical sports: a platform designed with this type of anchoring is ideal for the hotel and recreation industry, since most of the potential customers of this type of facilities are not expert sailors and the fact that it moves very little is highly attractive; a hotel can be installed, placing it in extraterritorial waters more than 10 nautical miles from the coast, so it could have rest facilities, recreation, casino and gaming rooms, theme parks or any type of facilities for which an equivalent installation on land could find urban impediments or have difficulties in obtaining opening permits or have problems with current municipal regulations; being far from the coast, the depth of the sea is greater and it is not possible to support the hotel on the seabed; in addition, the waves are greater, so a conventional platform would move too much for this application.
- Wind farms. Windmills need a base that moves as little as possible, in fact, once a certain level of inclination (pitch) or a certain level of acceleration is exceeded, the wind turbines must be stopped for safety reasons. The fact that it moves less than current ones increases the profitability of the installation, by having more net hours per year to generate electricity. In fact, all the preferred embodiments presented in this patent application refer to platforms specifically designed as a support for marine wind turbines.
- Alternative energies. By its very nature, the proposed system reduces the pitch angle of the platform by drawing energy from the translation movement of the main float (flotation element). This is done by incorporating an electric generator to one of the pulleys (2 or 3) of the shock absorber lines. The electrical energy generated can be used for the own consumption of the installation or sent to earth through the corresponding electrical cable. Indeed, the present invention may be approached from two points of view:
 - As a collector of renewable energies: It is a system that extracts energy from the movement of the platform caused by the waves, simultaneously cancelling the inconvenient pitch and roll movements of the platform;

- As a comfort device: It is a system that overrides the pitching movements of the platform, which can also generate energy from the waves.

From the second point of view, the energy extracted from the damping lines can be dissipated directly in the form of heat or can be converted into electrical energy. If it is dissipated, the necessary equipment is cheaper and simpler, the movements of the platform would be the same but the full potential of the system is not exploited. If it is decided to use the available energy, it can be stored in batteries or consumed on board in the facility.

[0044] Thus, one or more damping lines with or without energy collectors may be included in the anchoring. The fundamental mission of these lines is to reduce the vibrations (oscillations) that can occur as a result of the elasticity of the anchoring cables, in a system that is conceptually quite rigid (in general it is a hyperstatic system). These low/medium frequency vibrations could significantly increase the accelerations on the platform and render it unacceptable. The incorporation of the shock absorber lines almost completely cancels out these vibrations (oscillations).

[0045] These damping lines are very similar to the locking anchoring lines (the anchoring lines attached to an anchoring element or pile on the seabed), with the difference that one of their pulleys (internal or external) drives an electric generator (if the energy is to be used) or a hydraulic or electrical dissipator (if they only function as dampers).

Brief description of the figures

[0046] As part of the explanation of at least one embodiment of the invention, the following figures have been included, by way of illustration and in a non-limiting manner.

Figure 1: Shows a front schematic view, in the resting position, of two anchoring lines (arranged in the same plane) according to a possible embodiment of the anchoring system object of the present invention.

Figure 2: Shows a schematic view of the theoretical displacement of two central anchoring lines, in a counterbalanced anchoring system according to the state of the art.

Figure 3: Shows a diagram of the forces acting on a structure employing the anchoring system object of the present invention.

Figure 4: Shows a schematic view similar to that of figure 1, where the buoys of the bottom sections of the anchoring lines have been suppressed.

Figure 5: Shows a schematic view of the anchoring system of figure 4, wherein said anchoring system has been displaced horizontally and vertically by the effect of waves and wind.

Figure 6: Displays a schematic view of the displacement of an anchoring system in which the bottom sections of diametrically opposed anchoring lines are parallel.

Figure 7: Displays a schematic view of the displacement of an anchoring system in which the bottom sections of diametrically opposed anchoring lines are divergent.

Figure 8: Shows a schematic perspective view of an anchoring system according to the present invention, wherein two pairs of anchoring lines (i.e., four anchoring lines) arranged in two perpendicular planes are observed.

Figure 9: Shows a top view of the anchoring system of figure 8.

Figure 10: Shows a front schematic view of a first phase of installation of a anchoring system according to the present invention, wherein four protruding structural arms of the floating platform (two of them in a plane perpendicular to the view of the figure) are observed, which support four anchoring lines of two pairs of anchoring lines, and wherein the second portion (upper portion) of the bottom sections of the anchoring lines has not yet been connected to the buoys of the first portion (lower portion) of the bottom sections of the anchoring lines.

Figure 11: Shows a schematic view of the anchoring system of figure 10, wherein the second portion of the bottom sections of the anchoring lines has already been connected to the buoys.

Figure 12: Shows a schematic view of the anchoring system of figure 11, wherein the floodable chambers of the flotation elements and the counterweight have been flooded.

Figure 13: Displays a side schematic view of a first embodiment of the anchoring system according to the present invention, wherein a floating platform comprising a cylindrical-conical shaft-shaped main structure with four projecting structural arms supporting four anchoring lines is observed, and wherein the main structure of the floating platform comprises four spokes connected with said main structure, each of the spokes comprising a floating element at its end.

5

Figure 14: Displays a perspective view of the anchoring system of figure 13.

Figure 15: Displays a front schematic view of the anchoring system of figure 13 and figure 14.

10

Figure 16: Shows a side schematic view of a second embodiment of the anchoring system according to the present invention, wherein a floating platform is observed comprising a cylindrical-conical shaft-shaped main structure with four projecting structural arms supporting four anchoring lines, and wherein the main structure of the floating platform comprises three floating elements.

15

Figure 17: Displays a perspective view of the anchoring system of figure 16.

Figure 18: Displays a front schematic view of the anchoring system of figure 15 and figure 16.

20

Figure 19: Shows a front schematic view of a third embodiment of the anchoring system according to the present invention, wherein a floating platform comprising a floating ring-shaped main structure, with four projecting structural arms supporting four anchoring lines, is observed.

Figure 20: Displays a perspective view of the anchoring system of figure 19.

25

Figure 21: Displays a side schematic view of the anchoring system of figure 19 and figure 20.

Detailed Description

[0047] The present invention relates, as mentioned above, to an anchoring system comprising a floating platform (100).

30

[0048] Some elements cited in this description are defined below.

[0049] Float or flotation element (500): a closed and watertight wrapper, totally or partially submerged in water, which can be subjected to hydrostatic or hydrodynamic forces due to waves or sea currents. If it is partially submerged, it can also be subjected to forces originating from the wind on its side or superstructures.

35

[0050] Hull or main structure (400): a structure comprising one or more watertight floats or flotation elements (500) that form a rigid and resistant assembly, in which at least one of them is partially submerged.

[0051] Floating platform (100): a hull or main structure (400) of any shape or configuration, which additionally comprises other elements or structures (spokes (600), protruding structural arms (12), floating elements (500), etc.), dedicated to any function (accommodation, industrial or recreational facilities, windmill support, etc.), equipped with the anchoring system proposed herein.

40

[0052] External agents: the wind, sea currents, waves, internal load movements or any element external to the floating platform (100) that tries to move it away from its design position or tries to transmit pitch or roll movements.

[0053] Tension of the cable or anchoring line (200): tensile force to which the cable or anchoring line (200) is subjected (due to its flexible nature, the cable cannot be subjected to compressive forces).

45

[0054] Central counterweight (1): a fully submerged hull, of average density greater than 1.2 kg/dm³, which keeps the anchoring lines (200) that are connected to it taut. In simple installations there is only one counterweight (1) located on the central axis (300) of the floating platform (100), but there may be several counterweights (1) or be located below other points of the floating platform (100).

[0055] Anchor block or bottom weight (4): a (large) weight supported on the seabed (5), to which the cables or anchoring lines (200) of the anchoring system are attached. In other conventional installations, it is equivalent to the anchor, to the 'deadweight' that keeps buoys or other marine elements in their position or to any other type of anchorage by means of piles.

50

[0056] Anchor cable or anchoring line (200): a cable, chain or tie of any type that keeps the floating platform (100) attached to the bottom weight (4), preventing the floating platform (100) from being dragged by external agents. Each anchoring line (200) is composed of the following elements:

55

- Bottom section (8): the part of the anchoring line (200) that joins the bottom weight (4) with the first rotary fixing means (3) (or external pulley) of the anchoring line (200). In most applications, in the projected conditions the bottom section (8) is completely vertical, although in special cases it may be slightly divergent. In some cases it can be in a single piece

reaching the seabed (5); in other cases, the bottom leg (8) is split or divided into a first portion (bottom portion) and a second portion (top portion), and both portions (top and bottom) are joined together by an intermediate buoy (9).

- Intermediate section (7): the part of the anchoring line (200) that joins the outer pulley (the first rotary fixing means (3)) with the inner pulley or pulleys (the second rotary fixing means (2c) and, eventually, the third rotary fixing means (2d)) that hold the cable; it can be horizontal or it can have a slight slope (if the pulleys are not at the same height).

[0057] More specifically, as will be seen below, the anchoring line 200 comprises a cross subline (200c) and a direct subline (200d). The intermediate section (7) is the part of the cross subline (200c) of the anchoring line (200) that joins the first rotary fixing means (3) (or external pulley) with the second rotary fixing means (2c) (or internal pulley).

[0058] In addition, in the case of a third rotary fixing means (2d) (or internal pulley), the intermediate section (7) also refers to the part of the direct subline (200d) of the anchoring line (200) that joins the first rotary fixing means (3) with the third rotary fixing means (2d).

- Central section (6): the part of the anchoring line (200) that joins the inner pulley (or each of the inner pulleys) with the central counterweight (1).

- Intermediate buoy (9): an optional element which can be interposed in the bottom section (8) of each anchoring line (200). The buoy (9) is attached to the seabed (5) by a cable (a first portion of the bottom leg (8) of the anchoring line (200)). The first portion of the bottom leg (8) may comprise one or more cables or chains in parallel. The advantage of using this buoy (9) is that it can be pre-installed when the ground is conditioned and the bottom weights (4) are put in place, levelling it at the correct height so that then, when installing the floating platform (100), one only has to connect the anchoring lines (200) (the second portion of the bottom section (8) of each anchoring line (200)) to the buoy (9), which come prepared with their correct length, significantly accelerating the installation process of the floating platform (100).

- Central axis (300) of the anchoring system: a vertical axis that passes through the center of gravity of the counterweight (1) in its resting (or projected) position. Preferably, this central axis (300) constitutes a central axis (300) of symmetry of the floating platform (100).

- Anchoring subline (generic): the basic unit of the anchoring system, composed of the following elements:

- A mooring weight (or bottom weight (4)) supported on the seabed (5) (which may be shared by several mooring sublimes);

- A first rotary fastening means (3) (or external or external pulley): fixedly or partially flexible (or rotating/tilting) fastened to the floating platform (100), close to the vertical of the bottom weight (4);

- One or two internal or inner pulleys (2) (a second rotary fixing means (2c) and, optionally, a third rotary fixing means (2d)): fixedly or partially flexible (or rotating/tilting) fastened to the floating platform (100), at some point of the floating platform structure (100). Despite their name, they are at a certain distance from the central axis (300) of the floating platform (100);

- The corresponding part of the central counterweight (1) (several cables must necessarily share the same counterweight (1));

- A cable that joins all these elements, composed of the sections defined above (central section (6), intermediate section (7) and bottom section (8));

- Optionally there may be an intermediate buoy (9) sandwiched in the bottom section (8);

- Optionally there may be some intermediate pulleys (rotary guiding means (11)), which serve to support the intermediate section (7) of the cable of the anchoring sublimes, or which help to orient the cable by the most suitable path.

Some of the pulleys described above can be self-adjustable, to adapt to the direction variations suffered by the central section (6) and the bottom section (8), due to the movements of the floating platform (100).

- Protruding structural arms (12): on floating platforms (100) in which the external pulleys (first rotating fixing means (3)) are farther from the central counterweight (1) than the perimeter of the main structure (400) of the floating platform (100), these protruding structural arms (12) are extensions of the bracket-shaped helmet (or any other type of structure) which serve to clamp the external pulleys (first rotating fixing means (3)), inner pulleys (2) (second rotating fixing means (2c) and, optionally, third rotating fixing means (2d)) or intermediate pulleys (rotating guiding means (11)).
- Crossed subline (200c): An anchoring subline in which the inner pulley (second rotary fixing means (2c)) is beyond the central axis (300) of the floating platform (100), almost diametrically opposite the corresponding outer pulley.
- Direct subline (200d): An anchoring subline in which the inner pulley (third rotary fixing means (2d)) is very close to the outer pulley (first rotary fixing means (3)). However, it is also possible that the direct subline (200d) does not have an inner pulley (third rotary fixing means (2d)); in this case, the cable is directed from the outer pulley (first rotary fixing means (3)) directly to the counterweight (1).

[0059] A complete anchoring line (200) is a set of two anchoring sublimes (a direct subline (200d) and a cross subline (200c)), which share the same bottom weight (4), a part of the bottom section (8) of the anchoring cables and the corresponding part of the central counterweight (1). Its external or external pulleys (first rotating fixing means (3)) are very close to each other; in general, they are parallel with the same axis of rotation. On platforms using protruding structural arms (12), these outer sheaves hang from the end of the same protruding structural arm (12). Instead of two outer sheaves, it may comprise a single outer sheave with at least two sheaves (one sheave for the direct subline 200d and another sheave for the cross subline 200c).

- Locking line: a generic anchoring line (200) (as described above) in charge of maintaining the verticality of the floating platform (100). Its elements are large, as they can be subjected to great stresses in their anchoring cable, especially in the floating platforms (100) that serve as support for wind turbines.
- Shock absorber line: an anchoring line (200) with some variations:
 - One of its pulleys (the inner or the outer one interchangeably) is connected with an electric generator through a gearbox (or to a hydraulic motor that moves a generator), which allows to capture the energy of the movement of the floating platform (100);
 - The central section (6) of the anchoring cable has a more elastic part (which functions as a spring), so that it absorbs variations in length with respect to the locking lines;
 - The voltage of the cable is limited by the electrical characteristics of the generator and is much lower than the voltage of the locking lines;
 - The size of its elements (cable diameter, pulleys, supports...) is also smaller, due to the lower stresses to which its cable is subjected. In fact, they may be made of other materials that are less resistant than the locking lines.
- Parallel anchoring line (200): an anchoring line (200) in which its bottom section (8) is vertical (in its resting position), as shown in figures 1 to 6; all the bottom sections (8) remain parallel even if the platform moves.
- Divergent anchoring line (200): an anchoring line (200) which in its bottom section (8) (the one fastened on the seabed (5)) is not vertical, but instead is inclined outward (forming an angle (A) with the vertical), that is, the lower end of the anchoring line (200) is further away from the central counterweight (1) than the outer pulley (figure 7).
- Group of anchor lines (200): It is the set of several anchoring lines (200) (locking or damping) that share a common central counterweight (1). The resulting arrangement is necessarily radial, although each branch may have different size (distance between the centerline axis and the outer pulley). All the internal pulleys of the group must be at the same distance from the central axis (300) of the floating platform (100) (which coincides with the vertical of the counterweight (1)).

[0060] Floating platforms (100) with very elongated geometries may have installed several groups of anchoring lines 200 acting on the same counterweight (1) (the centerlines of each group of anchoring lines 200 are fastened to different points of the counterweight (1), which is also elongated).

[0061] On particularly large floating platforms (100), there may be several groups of anchor lines (200), each group having its corresponding counterweight (1).

[0062] In all the preferred embodiments shown in the figures, the anchoring system has only one group of anchoring lines (and therefore a single counterweight (1)).

- 5
- SLP (Soft Leg Platform): a floating platform (100) on which the anchoring system proposed in this patent application has been installed. In each complete anchoring line (200) there are two anchoring sublimes (200d, 200c), whose inner pulleys (second rotary fastening means (2c) and third rotary fastening means (2d)) are at the same distance from the central axis (300) of the floating platform (100). Each anchoring line (200) is composed of a direct subline (200d) and a cross subline (200c), whose inner pulleys (second rotary fixing means (2c) and third rotary fixing means (2d)) are located symmetrically with respect to the vertical central axis (300) passing through the central counterweight (1), as can be seen in figures 8 and 9.
 - Central well (optional, not shown in the figures): a hole that vertically crosses the entire floating platform (100), just below the inner pulleys, for the passage of the pendulum (cables of the central section (6) and counterweight (1)); if the inner pulleys are very far apart from the vertical of the central counterweight (1), the central well is unnecessary.
- 10
- 15

[0063] Most of the elements that make up the proposed system have been described above. There are other optional elements that can help the proper functioning of the main elements and other elements that can help the actual implementation in a given platform.

[0064] The simplest configuration is composed of four locking anchoring lines (200), each of which is composed of two sub-lines (one direct (200d) and one cross (200c)), each of which includes:

- A bottom weight (4) supported on the seabed (5);
 - Two rotary pulleys or fixing means (2, 3): an outer pulley (or first rotary fixing means (3)) and another inner pulley (second rotary fixing means (2c)); optionally, there may be a second inner pulley (or third rotary fixing means (2d)) for the direct subline (200d) of each anchoring line (200);
 - A central counterweight (1), common to the four anchoring lines (200);
 - A cable (in each subline) that joins the bottom weight (4) with the central counterweight (1), passing through the outer pulley (first rotary fastening means (3)) and the inner pulley (second rotary fastening means (2c) or third rotary fastening means (2d)), defining three sections (6, 7, 8) in sublimes (200c, 200d) that have inner pulleys:
 - The central section (6) of the anchoring cable, which joins the inner pulley (second rotary fastening means (2c) or third rotary fastening means (2d)) with the central counterweight (1). Its length depends on the vertical position of the central counterweight (1). Optionally, the portion of the cable closest to the central counterweight (1) has been referred to as the anchoring cable adjustment leg and can be used to adjust the total length of the cable to irregularities of the bed or seabed (5) at the point where the floating platform (100) is to be placed;
 - The intermediate section (7) of the anchoring cable, which joins the inner pulley (second rotary fastening means (2c) or third rotary fastening means (2d)) with the outer pulley (first rotary fastening means (3)), and which has a constant length due to its nature;
 - A bottom section (8) of the anchoring cable, which joins the outer pulley (first rotary fixing means (3)) with the bottom weight (4). Its length depends on the geographical position of the platform (i.e. the depth of the seabed (5)). Optionally, this bottom section (8) may be divided into two parts or portions that are attached to an intermediate buoy (9). In this way the installation and maintenance operations of the cables are facilitated.
- 25
- 30
- 35
- 40
- 45

[0065] Since the three sections (6, 7, 8) are part of the same cable, the sum of their lengths is constant. The mission of these elements is to prevent the roll and pitch movement of the floating platform 100, allowing it to move horizontally or vertically.

[0066] If the floating platform (100) moves vertically a height V, the counterweight moves vertically a height 2V, but the forces on the floating platform (100) hardly vary.

[0067] If the floating platform (100) moves a quantity H horizontally, the anchoring lines (200) generate an opposing horizontal force that tends to return the floating platform (100) to its original position. The vertical forces on the floating platform (100) hardly vary. The counterweight (1) moves slightly upwards.

[0068] If a bending moment is applied that attempts to cause the floating platform 100 to rotate in the pitch direction, the

tensions of the cables of the anchoring lines 200 vary to compensate for it and prevent rotation; if that bending moment increases sufficiently, one of the anchoring lines 200 will lose its tension and the floating platform 100 will be held only by the other anchoring lines 200. In general, the hull or central structure (400) of the floating platform (100) will begin to submerge slightly.

5 **[0069]** When all but one of the anchor lines (200) have been untensioned, the overturning of the floating platform (100) may begin. This overturning will be reversible or irreversible depending on the particular geometry of the assembly as a whole.

[0070] The theoretical basis of the invention is based on a geometric construction, as can be seen in figure 2.

10 **[0071]** Each anchoring cable can be considered almost non-extensible. If we assume it consists of three sections with lengths: T6 (length of the central section), T7 (length of the intermediate section) and T8 (length of the bottom section), the sum of lengths (T6, T7, T8) of the three sections (6, 7, 8) is constant: $T6 + T7 + T8 = \text{constant}$.

[0072] Since the intermediate section (7) does not vary in length, it is also fulfilled that: $T6 + T8 = \text{constant}$.

15 **[0073]** The floating platform (100) has two anchoring lines (200) (if planar movement is assumed, if three-dimensional movement is considered there would be at least four anchoring lines (200), crossed two to two, but the result is the same). If we compare the lengths of the sections in two different positions of the platform:

- Projected condition: it has two lines (P and Q), each with the aforementioned three sections;
- Any other position: the lines are transformed into (R and S).

20 **[0074]** Since each line (P, Q, R, S) maintains its length:

$$T6(P) + T8(P) = T6(R) + T8(R) \quad \text{and} \quad T6(Q) + T8(Q) = T6(S) + T8(S)$$

25 **[0075]** Since

$$T6(P) = T6(Q) \text{ and } T6(R) = T6(S)$$

30 (they represent the same measure).

[0076] If we start from two symmetrical lines, i.e.

$$T8(P) = T8(Q), \text{ then } T8(R) = T8(S)$$

35 **[0077]** That is, the two outer pulleys (first rotary fixing means (3)) and the two bottom weights (4) form an "articulated" quadrilateral in which their opposite sides are equal and therefore the upper side always remains parallel to the lower side, regardless of the position of the center of the floating platform (100).

40 **[0078]** To block the rotation of the floating platform (100) in a plane, two anchoring lines (200) are sufficient, as seen in figures 1 or 2. For example, if the pitch angle is to be avoided, two anchoring lines (200) are needed in a longitudinal plane, with one outer pulley at the bow and one outer pulley at the stern, with the two inner pulleys between them (the intermediate sections of the anchoring cable need not be the same). If the roll angle is to be avoided, the two anchoring lines (200) must be in a plane transverse to the waves.

45 **[0079]** Figures 4 and 5 show a schematic of a complete anchoring line (200) formed by a forward subline (200d) and a cross subline (200c), representing the positions of the floating platform (100) in its design condition (figure 4) and in any other position (figure 5).

50 **[0080]** The two inner pulleys (2d: direct and 2c: cross) are at the same distance from the central axis (300) of the floating platform (100) (actually the pulley axes are at different distances, but such that the central sections (7) appear to come from symmetrical points: the point of contact of the cable with the pulley). In the design condition (figure 4), the lengths of the two sublimes (200c, 200d) are different, but are such that the central sections (6d, 6c) are equal, so that the central counterweight (1) is located in correspondence with the central axis (300) of the floating platform (100).

55 **[0081]** When the floating platform (100) is moved (figure 5), the bottom sections 8d and 8c change in length, but remain equal to each other. The intermediate sections (7d and 7c) do not vary in length (the pulleys move rigidly with the platform). Since the total length of each subline (200c, 200d) does not vary, the central sections (6d and 6c) also vary in length, but remain equal to each other, i.e. the central counterweight (1) moves vertically, but remains located in correspondence with the central axis (300) of the floating platform (100). In this way, the pendular movement that the counterweight (1) could have in the original version of the anchoring system is totally eliminated.

[0082] When two complete anchor lines (200) are combined (each with a direct subline (200d) and a cross line (200c)), applying the same reasoning as when the lines are central (on state-of-the-art platforms with central well through which the

central lines pass), the bottom sections (8) of each complete anchoring line (200) remain equal to each other, regardless of the position of the floating platform (100). In this sense, the anchoring system (with direct (200d) and crossed (200c) sublimes) behaves as if all the sublimes were central.

[0083] The scheme of operation of the system with direct (200d) and crossed (200c) sublimes, can be seen in figure 3. If it had only central sublimes it would be the same scheme, with the angle (β) between the central sections (6) being null (i.e. they would be vertical).

[0084] When the external agents (winds, waves or sea currents) act on the floating platform (100), they generate a bending moment (M_f) and a force (F_x) that pushes the floating platform (100) to the position seen in the figure.

[0085] On the other hand, the central counterweight (1) has a net weight (dry weight minus hydrostatic thrust) that tensions the two cables of the anchoring lines (200) generating two forces, in windward (F_1) and leeward (F_2). If the inertia forces due to the movements of the floating platform (100) and the counterweight (1) are ignored, the forces on the direct and cross cables on each side are equal:

$$F_{1c} = F_{1d} = F_1/2, \text{ and } F_{2c} = F_{2d} = F_2/2$$

[0086] Due to the balance of forces in the counterweight, it is fulfilled that:

$$(F_1 + F_2) \times \cosine(\beta) = P$$

[0087] These forces are transmitted by the cable to the bottom weights (4).

[0088] For the floating platform (100) to be in equilibrium, the two forces F_1 and F_2 applied on the bottom sections (8) must fully compensate for the bending moment of the external agents (M_f).

$$(F_1 - F_2) \times \text{External pulleys distance} \times \cosine(\alpha) = M_f$$

[0089] Since the cables do not work by compression, as long as F_2 is positive, the floating platform 100 will remain horizontal and then begin to tilt leeward.

[0090] On the other hand, the balance of horizontal forces requires that:

$$F_H = F_1 \times \sine(\alpha) + F_2 \times \sine(\alpha) = P \times \sine(\alpha) / \cosine(\beta) = F_x$$

[0091] According to a variant of the anchoring system wherein the anchoring lines (200) are divergent, the pitch angle imposed by external forces acting on the floating platform (100) can be corrected. The elasticity of the anchoring lines (200) means that when the floating platform (100) is subjected to external forces, the windward cables lengthen and the leeward cables shrink: as a result of these deformations the floating platform (100) acquires a small pitch angle leeward.

[0092] The indicated variant consists of giving an angle to the bottom sections (8) of the anchoring lines (200), separating out the anchoring points of the vertical of the outer pulleys (first rotary fixing means (3)), as can be seen in figure 7.

[0093] When the floating platform (100) is moved horizontally dragged by the wind, the deck of the floating platform (100) does not remain horizontal and instead turns windward. This angle of rotation is geometrically related to the angle of the bottom sections (8) and to the depth of the seabed (5), being approximately proportional to the magnitude of the horizontal movement. By adjusting the angle of the bottom sections (8) of the anchoring lines (200), the pitch of the floating platform (100) can be cancelled exactly due to the elasticity of the anchoring lines (200), whatever the horizontal force applied (until any of the lines are deployed).

[0094] Below are proposed, by way of example, three alternatives for fastening the cables of the bottom section (8) on the seabed (5). In all of them, intermediate buoys (9) can be included in the bottom sections (8) (located at a depth similar to that of the counterweight (1), in its design position) joined by cables or chains to the anchorage on the seabed (5).

[0095] In this way, the final installation is very simple, since it is enough to hold the cables in the buoys (9) and the floating platform (100) is fully operational.

- A mooring ring may be used, for example by joining all the bottom weights (4) together by a rigid structure, including fastening points for the cables at the appropriate locations. This structure includes several ballast tanks, which are initially empty so that the assembly has a slightly positive buoyancy. This structure is moved to the wind farm and sunk in the place where the floating platform (100) will be installed. This operation does not require great precision, since it is certain that the anchor points will be correctly positioned, regardless of the position in which the ring is on the seabed (5). When the floating platform (100) is placed in its installation site, it is sufficient to fasten the cables on the anchors for

the floating platform (100) to be operational;

- Piles inserted in the seabed (5) may be used. This system is copied from the foundations of TLP type platforms. The seabed (5) is prepared and piles including the anchor points of the anchor lines (200) are inserted. The fundamental difference with the TLP system is that the tensile stresses that must be withstood with the anchoring system of the present invention are much lower than on a TLP platform, in fact, for an equal installed power, the stresses are of the order of one fifth or less. This makes the preparation of the anchorage much cheaper and easier.
- Bottom weights (4) previously located on the seabed (5) may be used. Due to the low voltages of the cables, individual bottom weights (4) can be used which are located precisely on the seabed (5), on a pre-prepared esplanade. This is an intermediate solution between the anchoring ring (which is a very large structure but simple to place) and the use of piles (requiring certain preparation of the ground and placing the background weights (4) accurately).

[0096] Comparison of the anchoring system of the present invention with TLP (Tension Leg Platform) platforms: Apparently, floating platforms (100) with a TLP-type anchoring system serve the same purpose as a floating platform (100) with the anchoring system of the present invention. Their aim is to override the pitch/roll movement of the floating platform (100). However, the principle of operation of both is radically different and their kinematic and dynamic characteristics are also different, as can be seen in the following table:

Characteristic	TLP Platform	SLP platform (anchoring system of the present invention)
Upright position	Almost constant, moves in an arc of circumference, with center in the anchoring weights	Completely free, within the design range (the range depends on the length of the central sections)
Pitch angle	Theoretically null, it depends on the elasticity of the anchoring lines	Depends on the bottom section: -Vertical: theoretically null -Divergent: inverse controllable or zero
Design voltage in the cables	Very high	Moderate, less than $1/5$ of TLP platform voltages Comparable to a traditional anchorage
Average voltage in the cables under static conditions	Grows with tide level and horizontal movements	Almost constant in any sea conditions, as long as the counterweight does not get too close to the platform
Possibility of loss of tension in the leeward cable.	Due to external bending moment Due to low tides Due to very large waves	Due to external bending moment Due to very large waves
Bending moment at the base of the tower	Somewhat higher than an land windmill	May be less than that of a land windmill (divergent lines)
External appearance	Very high and slender platforms	Low-height, flattened platforms (any shape)
Environmental impact	High environmental impact, especially at low tide	Reduced environmental impact, in any condition
Geometric requirements of the hull	Small floatation area None other relevant	None It can have any shape
Moving parts	None	Almost the entire anchoring system.
Transport to operating position	Very complex, needs special ships	Very simple, just a conventional tugboat
Installation	Very complex, requires positioning the bottom anchors with great precision	Very simple, it does not require conditioning of the ground, it is almost autonomous in its installation

(continued)

Characteristic	TLP Platform	SLP platform (anchoring system of the present invention)
Change of operational location	Almost impossible	Very simple, you just need a tugboat for the transport

[0097] The figures of the present patent application are described and discussed below.

[0098] In all the figures, the depth at which the seabed (5) is located has been reduced, so that the images are more proportionate and easier to interpret. If the seabed were so close, it would not be worth using floating platforms (100), since it would be better if they were directly supported on the seabed (5). In actual projects, the counterweight (1) would also be proportionally deeper than shown in the figures.

[0099] Figure 1 shows a basic diagram of the locking anchoring lines (200) (those that prevent the rotational movement of the floating platform (100)). An installation of this type consists of a floating platform (100) floating in the sea, provided with two or more anchoring lines (200) (the minimum is two anchoring lines (200) when you only want to override the rotational movement in one direction, such as pitching; the minimum is four anchoring lines (200) when you want to override pitch and roll simultaneously), each of which, at least, is composed of two sublimes (200d, 200c), each of which consists of: one (or two) inner pulley(s) (second rotary fixing means (2c) and third rotary fixing means (2d)) and an outer pulley (first rotary fixing means (3)), which support a cable or anchoring line (200) composed of three sections, a bottom section (8) that reaches a bottom weight (4) resting on the seabed (5), another central section (6) fastened to the central counterweight (1) and an intermediate section (7) that joins the other two sections (8, 6). The central counterweight (1) is shared by all anchor lines (200). The bottom section (8) can be divided into two portions, which are attached to an intermediate buoy (9); in this case, the lower portion (first portion) of this bottom section (8) is common to all the sublimes hanging from the same protruding structural arm (12). Two complete anchoring lines 200 have been depicted simultaneously in figure 1, one using a solid line (the one on the right) and the other (the one on the left) using a dashed line.

[0100] Figure 2 shows a scheme of the geometric principle that regulates the lengths of each section (6, 7, 8) of the anchoring lines (200) and justifies that the floating platform (100) always moves parallel to the initial position thereof. The scheme corresponds to central anchoring sublimes (where the floating platform comprises a central well) of a state-of-the-art anchoring system (as defined in ES 2629867 A2). This figure is provided to serve as a basis for and facilitate the comprehension of the operation of the anchoring system object of the present invention.

[0101] Figure 3 shows a scheme of the dynamic principle, with the forces acting on the anchoring lines (200) when the floating platform (100) is subjected to a force (Fx) and a bending moment (Mf) originating from the external agents (wind, waves or sea currents). The sum of the tensions on all the anchoring lines 200 is always constant (equal to the apparent weight of the central counterweight 1, divided by the cosine of the angle β between the central section 6 and the central axis 300); the difference between the tensions of the anchoring lines (200) is proportional to the applied bending moment and the horizontal force FH that is able to support the floating platform (100) is proportional to the sine of the angle α between the bottom sections 8 of the anchoring lines (200) and the vertical direction. If the cables of the bottom sections (8) of the leeward anchoring line (200) become loose, the platform loses its horizontal position (pitch or roll movements appear).

[0102] Figure 4 and figure 5 show a basic diagram of the anchoring system, similar to that of figure 1, in which the intermediate buoys (9) have been removed, so that the bottom sections (8d, 8c) of the direct subline (200d) and of the cross subline (200c) reach the bottom weight (4) that is in the seabed (5). Figure 4 shows the floating platform (100) in its resting position and figure 5 corresponds to the floating platform (100) when it has changed position (horizontal and vertical) due to the effect of wind and waves.

[0103] Figure 6 shows an operating diagram of the anchoring system with parallel anchoring lines (200), in which the bottom sections (8) are vertical in their resting position (dashed lines). When the floating platform (100) moves (solid line), the cover of the floating platform (100) is always kept horizontal.

[0104] Figure 7 shows an operating diagram of the anchoring system with diverging anchoring lines (200), in which the bottom sections (8) do not descend vertically to the seabed (5), but their layout forms an angle (A) with the vertical. When the floating platform (100) moves horizontally, it tilts windward. In the first approach it is as if it were rotating around the point of intersection of the two bottom sections (8). If the floating platform (100) is a marine wind turbine support, with a tower (13) and a wind turbine nacelle (14), the axial component of the weight of the nacelle (14) (due to the inclination of the tower (13)) can be made to exactly compensate the thrust of the wind on the blades of the rotor, so that the bending moment is annulled throughout the tower (13) of the wind turbine (and therefore the bending moments transmitted by the tower (13) to the floating platform (100)).

[0105] An example of the anchoring system comprising four anchoring lines 200 is shown in figure 8 and figure 9. This version of the anchoring system applies to floating platforms (100) with an even number of projecting structural arms (12). In this scheme, the inner pulleys (third rotary fixing means (2d)) of the direct subline (200d) have been eliminated, so that

the outer pulley (first rotary fixing means (3)) also performs the functions of an inner pulley and, of course, the intermediate section (7) of the direct subline (200d) has also been eliminated. The inner pulley (second rotary fixing means (2c)) of the cross subline (200c) appears to be next to the outer pulley (first rotary fixing means (3)), but this is an optical effect as said pulley corresponds to the cross subline (200c) of another protruding structural arm (12) (the opposite arm). Also shown in the are the intermediate pulleys (rotary guiding means (11)) of the crossed subline (200c) that divert the intermediate sections (7) of the crossed subline (200c) so that they do not cross the same sections of the perpendicular lines (in the "apparent crossing point", said sections pass at different heights).

[0106] Figure 10 and figure 12 correspond to the installation phases of a floating platform (100) stable in the ballast condition (in the figures the floating platform (100) with four protruding structural arms (12) has been represented, although it is valid for any such platform)). More specifically:

- In figure 10, the bottom anchors prepared to receive the floating platform (100) can be seen, with the intermediate buoys (9), the lower portions (first portions) of the bottom sections (8) of the anchoring lines (200) and the bottom weights (4). The floating platform (100) is in its ballast condition, with the floating elements (500) comprising a submerged zone (15) another emerging zone (16) above a floating line (21), and where the central counterweight (1) is centrally located below the floating platform (100). The anchoring lines 200 are connected to the counterweight 1, but not connected to the buoys 9.
- Figure 11 shows the upper portions (second portions) of the bottom sections (8) of the anchoring lines (200) already connected to the buoys (9) and the counterweight (1) has been partially flooded, tensioning the cables and sinking towards its design position. The floating platform (100) is somewhat deeper than in the ballast condition, but has not yet reached the operating condition (wherein the waterline (21) is located in correspondence with the operating draft (22)). The spokes (600) of the floating platform 100 are completely out of the water and the floating platform (100) retains all its stability.
- Figure 12 shows the floating platform fully installed, with the floodable chambers of the counterweight (1) flooded and the cables working with their nominal voltage. The floating platform (100) is already in its operating draught (22), ready to enter service.

[0107] Figure 13, figure 14 and figure 15 correspond to a first embodiment of the invention. These figures show a floating platform (100) that serves as a support for a marine wind turbine, which is stable in its ballast condition, with four anchoring lines (200). The floating platform (100) has two main loading conditions: the ballast condition, wherein the floating line (21) passes through an intermediate point of the floating elements (500) (which divides them into two parts: a submerged zone (15) and another emerging or emerged zone (16), which is only submerged in the operating condition) and the operating condition, wherein the floating line (21) is already in correspondence with the operating draught (22) and passes through an intermediate point of the spokes (600) (distinguishing a submerged radio zone in the operating condition (17) and another never submerged zone (18)). The spokes 600 are attached to the hull in a shaft which, in this case, comprises a structural ring (19) having eight rectangular faces (where the four radii (600) and the four protruding structural arms (12) meet) and eight other trapezoidal faces joining the rectangular faces. Four protruding structural arms (12) serve to support the outer pulleys (first rotary fixing means (3)) and the inner pulleys (only the second rotary fixing means (2c) and not the third rotary fixing means (2d) of the anchoring lines (200) have been represented). On the structural ring (19) there is a small truncated superstructure (20) for the electronic equipment of the floating platform (100) on which the tower (13) of the wind turbine rests.

[0108] Figures 13, 14 and 15 show three views of the floating platform (100), with direct (200d) and crossed (200c) sublimes. Figure 13 shows a (side) profile view of the assembly, aligned with the spokes (600) or legs of the floating platform (100) holding the submerged floating elements (500). Figure 15 shows a front view of the assembly aligned with the protruding structural arms (12) supporting the outer pulleys (rotated 45 ° with respect to the spokes (600), arranged in the bisectors between the spokes (600)). Figure 15 shows a first arm (12a) and a second arm (12b) belonging to a pair of protruding structural arms (12) located in the same plane. Figure 14 shows a 3D view of the assembly.

[0109] The protruding structural arms (12) comprise a first end (121) attached to the hull or main structure (400) of the floating platform (100) and a second end (122) projecting outwardly from the floating platform (100).

[0110] Figure 16, figure 17 and figure 18 correspond to a second embodiment of the invention. These figures show a floating platform (100) that serves as a support for a marine wind turbine, which is not stable in its ballast condition, with four anchoring lines (200) with direct sublimes (200d) and crossed sublimes (200c), in which an intermediate pulley (rotary guide means (11)) of diversion has been included in the intermediate section (7) of the anchoring lines (200). In this case the pulley is located horizontally and diverts the cables outwards, to avoid the superstructure (20) that supports the tower (13) of the wind turbine. The hull or main structure (400) is the simplest possible, a simple vertical axis cylinder, divided (conceptually) into three parts: a submerged area (15), which is always submerged (even in ballast condition), another

emerging or emerged area (16), which is only submerged in the operating condition. (These two parts together constitute the 'hull' of the floating platform (100)). It also has a never submerged zone (18), i.e. a part of the hull or main structure (400) that is out of the water in any load condition (analogous to the top of the spokes (600) of the floating platform (100) in the first embodiment). Like the floating platform (100) of the first embodiment shown in figures 13 to 15, in the second embodiment

the floating platform (100) also incorporates four protruding structural arms (12) and a small superstructure (20) on the hull that serves to support the tower (13) of the wind turbine.

[0111] Figures 16, 17 and 18 depict three views of the floating platform (100) of four protruding structural arms (12), respectively in profile, in 3D and front perspective (aligned with the protruding structural arms (12) of the floating platform (100)).

[0112] Figure 19, figure 20 and figure 21 correspond to a third embodiment of the invention, wherein a floating platform (100) is shown that serves as a support for a marine wind turbine, which is stable in the ballast condition. According to this third embodiment, the hull or main structure (400) of the floating platform has an annular geometry, forming a flotation ring (700). It has a central well, although it is not used as such (it is not used for the passage of counterweight cables). Four protruding structural arms (12) arise from the submerged hull or main structure (400). Figure 19 is a front view of the assembly (aligned with the protruding pulleys and structural arms (12)). Figure 21 is a side view, rotated 45° (oriented according to the bisector of the arms). Figure 20 is a 3D view of the assembly.

[0113] Although the proposed anchoring system is valid for any floating platform (100) (intended to support any type of structure), the present invention is especially indicated for two specific applications, as a support for offshore wind turbines and as a platform for offshore leisure. With regard to the object of the proposed patent (the anchoring system), the main difference between the two applications is the deck area of the floating platform (100), which causes the outer pulleys to hang from protruding structural arms (12) arranged radially, which protrude quite a bit from the deck of the floating platform (100), and on the platforms designed for marine leisure, causes the outer pulleys to hang from very short arms that protrude from the main deck of the platform.

[0114] The anchoring system according to the first embodiment of the present invention comprises the following elements:

- Four anchoring lines (200), each of which is formed by two anchoring sublimes (200c, 200d), each of the sublimes (200d, 200c) consists of an anchoring cable hanging from an outer pulley (first rotary fixing means (3)) and another inner pulley (2c, 2d), which in turn hang from a protruding structural arm (12) that serves as a support for the anchoring lines (200). The bottom section (8) of the anchoring cable of all the sublimes (of the same anchoring line/arm), is subject to a bottom weight (4) directly or through an intermediate buoy (9) and a common bottom section (first portion or lower portion of the bottom section (8)). The center leg (6) of all of the anchor lines (200) is subject to a center counterweight (1) that is common to all of the anchor lines (200).
- Floating platform (100): its hull or main structure (400) is attached to four vertical-axis cylindrical floats or flotation elements (500) arranged at the vertices of a square, sufficiently spaced apart from each other so that the central counterweight (1) fits in the center of the platform with the necessary clearances. The floating elements (500) are attached to the hull or main structure (400) of the floating platform (100) by means of four 'legs' or inclined spokes (600) that coincide in a reinforced structural ring (19) located under the superstructure (20) of the floating platform (100), well above its operating draught (22). Also joined in this structural ring (19) are the four protruding structural arms (12) that hold the sheaves of the anchoring lines (200) (the outer sheaves (first rotary fixing means (3)) and the inner sheaves (second rotary fixing means (2c) and third rotary fixing means (2d) if any). On this reinforced structural ring (19) there is a superstructure (20) on which the wind turbine tower (13) rests. In the ballast condition, the waterline 21 is located at approximately half-way from the flotation elements (500) and the floating platform (100) is stable by itself. In the operating condition, the operating draft (22) is located at half height of the spokes (600) and the flotation elements (500) are fully submerged.
- Central counterweight (1): a vertical axis cylindrical tank, weighted, but with a volume such that completely empty it has a positive buoyancy of the order of 10% of its volume. Internally it is divided into several ballast tanks or flood chambers that can be filled or emptied independently. With one of its chambers flooded, it has a slightly negative buoyancy. On its roof, there are four pairs of anchors to which the ends of the central sections (6) of all the sublimes (200c, 200d) of the anchoring lines (200) are fastened.
- Wind turbine: composed of a wind turbine tower (13) that rests on the main structure (400) of the floating platform (100) (on the superstructure (20) that is on the reinforced structural ring (19)) where the protruding structural arms (12) and the upper part of the spokes (600) are fastened. The tower (13) holds the nacelle (14), where the wind turbine itself is located. It is a commercial component, so it is not described in more detail.

- The submerged flotation elements (500) are accessible (for maintenance operations) through stairs located inside the spokes (500) of the floating platform (100). Said legs or spokes (600) are accessed through watertight doors located on the corresponding rectangular faces of the reinforced structural ring (19). This floating platform (100) has two modes of operation:

5 ◦ The transport (or ballast) condition, in which all its floodable chambers are empty and all the anchoring lines (200) are collected and float freely with no more constraints than the cable that joins them to the tugboat. In this condition, the floating platform (100) is stable on its own.

10 ◦ The operating (or design) condition, in which any of its ballast tanks or flood chambers is partially filled to get the platform to float in its operating (22) or design draught. The floating platform (100) is connected to the central counterweight (1) via the central sections (6) of all the anchoring lines (200) and to the seabed (5) via the bottom sections (8) of the anchoring lines (200). In this condition, the floating platform (100) has no stability on its own and depends solely on the stability provided by the anchoring lines (200).

15 **[0115]** In figures 13 to 15, three views of this first embodiment (in which its main elements have been identified) can be seen, with the proposed anchoring system.

20 **[0116]** In the anchoring system, according to the second embodiment of the present invention, unlike the first embodiment, in the ballast condition the floating platform (100) is not stable, so it is necessary to use a anchoring ring whose function is to give stability to the platform during the transport from the shipyard to the wind farm.

25 **[0117]** The main structure (400) of the floating platform (100) comprises a vertical axis cylinder, conceptually divided into three parts or zones: a submerged zone (15) under any load condition in the deepest part of the cylinder; an emerging or emerged zone (16) (intermediate zone) that is out of the water in the ballast condition and submerged in the operating condition and another never submerged zone (18) (upper part), which is always above the waterline (21). In addition, the floating platform (100) comprises four protruding structural arms (12) arranged radially (and of course the same number of anchoring lines (200)). The main structure (400) comprises a small superstructure (20) for the electrical equipment of the wind turbine, which also serves to support the tower (13) of the wind turbine.

30 **[0118]** In this second embodiment, the floating platform 100 is the simplest and most economical (of the three proposed embodiments), but has a different hydrodynamic behavior to the other two embodiments, since having much more floating area it tends to follow the movement of the waves, so its vertical movements are greater than those of the other embodiments; as a counterpart, it is able to capture more energy from the movement of the waves and the profile of the waves remains closer to its design floatation (operating draught 22), so it needs less freeboard than the other platforms.

35 **[0119]** In figures 16 to 18, three views of this second embodiment (in which its main elements have been identified) can be seen, with the proposed anchoring system with an intermediate pulley (rotary guide means (11)) horizontal in each intermediate section (7) of the anchoring cable, which serves to separate the cable from the superstructure (20).

[0120] The anchoring system according to the third embodiment of the present invention is stable in the ballast condition and comprises the following features:

- It has four protruding structural arms (12) arranged radially, with four anchoring lines (200);
- The reinforced structural ring (19) is located higher than in the other embodiments and the superstructure (20) is smaller (lower) than in the other embodiments and serves as a connecting element to the four legs or spokes (600), which are somewhat longer than in the other embodiments.
- The main structure (400) comprises an annular geometry, constituting a flotation ring (700) comprising at least one floodable chamber.

40 **[0121]** Three views of this third embodiment (in which its main elements have been identified) can be seen in figures 19 to 21. The direct sublimes (200d) do not have inner pulleys (third rotary fixing means (2d)), since the outer pulley (first rotary fixing means (3)) performs the two functions (inner and outer, to save space) and the cross sublimes (200c) use vertical intermediate pulleys (rotary guiding means (11)) to redirect the cable.

45 **[0122]** As can be seen in the figures, the reinforced structural ring (19) is raised so that the cables of the intermediate section (7) of the cross sublimes (200c) pass under the superstructure (20), between the legs or spokes (600) of the floating platform (100). If intermediate pulleys are included in this section to deflect the cable downwards, the reinforced structural ring (19) could occupy a lower position.

50 **[0123]** As already described, in the anchoring system of the present invention, on each of the anchoring lines (200) there is a direct subline (200d) and a cross subline (200c), wherein the inner pulley of the cross subline (200c) is located diametrically opposite the inner pulley of the direct subline (200d). This arrangement forces an even number of anchoring

lines (200) (and protruding structural arms (12)), and also causes the inner sheave of the direct subline (200d) of a first anchoring line (200) on a protruding structural arm (12) to be next to the inner sheave of the cross subline (200c) of a second diametrically opposite anchoring line (200), albeit on different sides of the protruding structural arm (12).

[0124] On floating platforms (100) for wind turbines that use protruding structural arms (12) to hold the pulleys, on each head there are two outer pulleys, a direct inner pulley (which can be omitted) and the crossed inner pulley of the diametrically opposite anchoring line.

[0125] Two projections of this anchoring system with four protruding structural arms (12) can be seen in figures 8 and 9; however, the floating platform (100) could have a different even number of protruding structural arms (12).

[0126] In this type of anchoring, the intermediate sections (7) of the crossed sublimes (200c) of the anchoring lines (200) can pass to another side of the floating platform (100) very close to its central axis (300) of symmetry; therefore, in the hull or in the superstructure, some holes can be made for these cables. An alternative used in the examples presented above, is to use intermediate pulleys (rotary guide means (11)) to deflect these cables and pass them under the superstructure (20) of the floating platform (100) (or on the outside of its sides).

[0127] Depending on the geometry of the floating platform (100) that the anchoring lines (200) are going to hold, the anchoring system may need some elements that facilitate its correct operation and that have already been introduced previously. Some of these elements can be seen in figures 8 to 11, others are normal elements in shipbuilding and have not been depicted in the figures. These include, but are not limited to:

- Intermediate pulleys for supporting the intermediate section (7) (rotary guide means (11)): the intermediate section (7) is shaped like a catenary supported on the inner and outer pulleys. A catenary varies in length according to the tension to which the cable is subjected. This phenomenon translates (if the distance between pulleys is large) in that in this part the cable acts as if it were more elastic than normal and could affect the operating principle of the system. To avoid this, intermediate support pulleys (rotary guide means (11)) can be placed on this section (which reduce the distance between supports and therefore drastically reduce the arrow of the corresponding catenary), so that the cable behaves almost as if it were in a straight line and the cable recovers its original rigidity. It also serves to reorient the intermediate section (7) (to avoid obstacles of the structure);
- Outer pulley support arms (protruding structural arms (12)): on floating platforms (100) that serve as support for a wind turbine, the diameter of the floating platform (100) is much smaller than the optimal distance to place the outer pulley. Protruding radial structural arms (12) are then needed that protrude from the main structure (400) of the floating platform (100) and from which the outer pulley hangs. Each protruding structural arm (12) may be a lattice structure (the elements are exposed to the weather) or a closed structure (the elements are protected from the weather); the choice of one type or another will depend on the philosophy of each specific design.

[0128] The floating platforms (100) that serve as a support for a wind turbine have several particularities, among others:

- The floating platform (100) does not need a large deck surface, it can be a small buoy that supports the weight of the wind turbine and its tower (13);
- The main force acting on the system and to be taken into account in the design is the aerodynamic thrust of the wind on the blades of the wind turbine rotor;
- The force of the wind exerts a very large bending moment on the base of the tower (13).

[0129] If the anchoring lines (200) in the design condition are not vertical (as seen in figure 13), but slightly divergent (as seen in figure 14), then, when the floating platform (100) is dragged by the wind the leeward pulley rises relative to the windward one; as a result, the floating platform (100) has a pitch angle opposite to the wind force. This pitch angle is proportional to the horizontal displacement of the floating platform (100) and is barely sensitive to the vertical movement thereof.

[0130] This angle causes the weight (Q) of the nacelle (14) to have an axial component opposite to the force of the wind on the rotor blades, which is proportional to the rotated angle, which in turn is proportional to the horizontal movement of the floating platform (100), which in turn is proportional to the force exerted by the wind. If these proportionality constants are properly synchronized, the axial component of the nacelle weight (14) can be made to cancel exactly the wind force, regardless of the wind speed.

[0131] In this way the bending moment at the base of the tower (13) due to the wind could be totally annulled. There would still be the forces and moments due to the waves, but they are lesser forces and moments. As a result:

- The tower (13) could be lightened, giving less thickness to its structural elements;

- The forces acting on the nacelle load bearings are reduced (14);
- Loads on the anchoring are reduced, and the structure of the floating platform (100) may be lightweight (and inexpensive to build).

5

[0132] On floating platforms (100) dedicated to marine leisure, the external agent that has the most influence on the comfort of passengers is the effect of the waves. With the anchoring system of the present invention, the rotating movements of the floating platform (100) are eliminated, the vertical movement has little influence (especially if a semi-submersible floating platform (100) is used), but the effect of the horizontal movement of the waves remains, which with severe seas can generate important accelerations (up to 1.5 m/s²).

10

[0133] In some applications, an anchoring system with divergent anchoring lines (200) may be used, producing a pitch opposite to the horizontal movement. This pitch can generate a longitudinal acceleration that opposes the acceleration of the horizontal movement, so that the resulting acceleration is lower than if the floating platform (100) moves without pitching; this would improve the comfort of the people on board.

15

[0134] A terrestrial analogy of this horizontal movement and of inverse pitch would be the movement of a swing or a hammock, which has great movements and turns, but does not generate the sensation of accelerations. In fact, the accelerations remain perpendicular to the surface of the deck of the floating platform (100) (perpendicular to the surface of the seat, in the case of the swing).

20

[0135] The operating scheme would be similar to that of figure 7, but with an angle (A) of divergence somewhat greater than that shown in this figure.

[0136] A difficulty that appears is that the cancellation of longitudinal accelerations can only be achieved for a relatively small range of waves, for example this cancellation can be achieved for waves between 8s and 10s; it is then a question of tuning these periods with the periods of the most likely waves. This tuning depends on:

25

- The geometry of the floating platform (100), its stability and its inertia;
- The geometry of the anchoring lines (200) and their elastic characteristics.

30

[0137] The cable of the anchoring line (200) is quite long, measuring at least the draught in the area of operation, plus the length of the protruding structural arms 12 (usually between 30 and 40m), plus twice the height between the pulleys and the sea surface, plus twice the maximum vertical travel of the floating platform 100 (maximum tidal height + wave height), plus 20% of the draught of the sea in the installation area, plus the margin that is deemed convenient.

35

[0138] In some applications, the bottom sections (8) do not reach the sea bed or bottom (5), but are fastened to an intermediate buoy (9) located relatively close to the sea surface and which is anchored to the sea floor (5) by means of chains or cables, so that in case of wear only the upper part of the cable, which is the most worn (and which is also the most accessible), has to be changed.

40

[0139] The length of the detachable cables must be such that, with the greatest foreseeable movements of the floating platform (100), the buoys (9) never approach the outer pulleys (first rotary fixing means (3)); if touched, a major breakdown could occur. The material of the anchoring lines (200) may be any suitable for these applications, including but not limited to:

45

- Twisted wire cable: there is no possibility of twisting, since the tension of the lines (applied according to the edges of a vertical prism) prevents the yaw rotation of the floating platform (100);
- Synthetic or textile material cable;
- Link chains: this is ideal for the intermediate section (7) (and the upper part of the other two sections (6, 8)) of the floating platforms (100) that serve as a support for a wind turbine, since it allows to use toothed pulleys (on the damping lines) and have relatively small turning radii. Its drawback is that it is noisier. For leisure facilities it is less recommended and should be very well acoustically insulated. On floating platforms (100) for marine leisure, the intermediate section (7) and the upper part of the other two sections (6, 8) should be of textile material, because with waves it will be moving continuously and will be quieter than a chain with links (which could cause noise problems in the structure).

50

55

[0140] One of the advantages of the anchoring system of the present invention is the ease of transport, installation and uninstallation of the platforms equipped with this anchoring system.

[0141] The installation procedure of the floating platform (100) is described in some detail below.

[0142] In the ballast condition, the submerged flotation elements (500) of the platform float at half height, giving the floating platform (100) all or part of the stability it needs for transport. The existence of a buoyancy reserve (materialized in

EP 4 353 577 B1

the emerging or emerged zone (16) of the floating elements (500)), allows the floating platform (100) to remain stable throughout transport, despite the pitching movements produced by the waves.

[0143] As already mentioned, in the case of the second embodiment of the anchoring system, in its condition of ballast, to guarantee its stability during transport the floating platform (100) also needs to be anchored to a anchoring ring.

[0144] Before moving the floating platform (100), the bottom anchors of the anchoring lines (200) are prepared. To do this, the bottom weights (4) are placed in their position, which can be of any type:

- Anchorages by means of piles;
- Individual bottom weights (4) located on a smoothed seabed area (5);
- A mooring ring, deposited on the seabed (5) by any method.

[0145] In these bottom weights (4), the common part (the first portion or lower portion) of the bottom sections (8) of the anchoring lines (200) that in turn secure the intermediate buoys (9) is fastened or fixed. The buoys (9) are levelled, so that they are all at the same depth and at the same distance from the central axis (300) of the floating platform (100).

[0146] This operation can be performed at the same time as the platform is built.

[0147] To transport the floating platform (100), a tugboat is enough to drag the floating platform (100) and the counterweight (1) to the wind farm. Optionally, the counterweight (1) may be positioned just below the floating platform (100) (held slightly by the central portions (6) of the sublimes (200c, 200d) of the anchoring lines (200)) and towed together. During transport, all ballast tanks or flood chambers of the floating platform (100) and of the counterweight (1) are kept completely empty. In this condition, the counterweight (1) has a slightly positive buoyancy, with a small freeboard with respect to its strut.

[0148] The first phase of the installation is very simple, just place the floating platform (100) on top of the anchors, with the counterweight (1) under the center of the floating platform (100), as can be seen in figure 10. At this stage it is not necessary to resort to any external stabilization system, since both the floating platform (100) and the counterweight (1) are stable *per se*.

[0149] Next, the upper portions (second portions) of the bottom sections (8) of the anchoring lines (200) are fastened to the intermediate buoys (9). The cables are prepared with the length they must have in the operating condition, so when they are hooked they will be untensioned (geometrically there is excess cable in this condition). To tension them, the floating platform (100) is moved slightly from its vertical position on the anchors (with the tug that has transported it), or the wind is allowed to laterally drag the floating platform (100) until these cables are slightly tensioned.

[0150] One of the tanks or flood chambers of the counterweight (1) is filled, so that it has a slightly negative buoyancy. The counterweight (1) begins to submerge and the tension of the cables returns the floating platform (100) to its position on the bottom anchors. With the floating platform (100) in place, ballast tanks or flood chambers of the counterweight (1) continue to be filled; as a result, the floating platform (100) gradually sinks dragged by the increasing weight of the central counterweight (1). In this phase, the floating platform (100) is in the situation shown in figure 11:

- The counterweight (1) is increasingly submerged, with an increasing net weight;
- The cables are substantially tensioned and provide the floating platform (100) with increasing stability;
- The floating platform (100) gradually sinks but retains all its initial stability, since the floating elements (500) have not yet completely sunk. The waterline (21) goes up from the ballast flotation towards the flotation in operation (operating draught (22)).

[0151] As the floating platform (100) sinks, there is a time when the floats or floating elements (500) are fully submerged. At that time, the stability of the floating platform (100) almost disappears (or is drastically reduced). This is not a problem, since the tension of the cables has already reached more than 50% of their nominal tension and are able to provide the floating platform (100) with all the stability it may need.

[0152] When all the ballast tanks or flood chambers of the counterweight (1) are fully filled with water, the floating platform (100) is almost operational, in general it will float a little above its design flotation (as it must have a certain safety margin in terms of its buoyancy). At this moment it is enough to introduce some ballast water into one of its tanks, so that the platform floats exactly as it was planned in its operating condition.

[0153] The assembly now has the appearance shown in figure 12. At this moment, the only thing missing is to make the electrical connections of the generator with the wind farm transformation plant, so that the wind turbine can operate normally.

[0154] To uninstall the floating platform (100), just follow the inverse process, that is:

- Disconnect the electrical circuits of the wind turbine from the power grid of the wind farm;
- Empty the floating platform ballast compensation tank (100) (i.e., empty the at least one flood chamber of the floating elements (500));
- Gradually empty the ballast tank (the at least one flood chamber) from the counterweight (1).

[0155] As this tank (the at least one flood chamber of the floatation elements (500)) is emptied, the floating platform (100) begins to lift (at the same time as the counterweight (1)). When the floating elements (500) reach the sea surface, the floating platform (100) regains full stability. When the cables begin to lose tension, the floating platform (100) will be dragged laterally by the wind until the counterweight (1) reaches the sea surface.

[0156] When the ballast tanks (flood chambers) of the counterweight (1) are completely empty (and the counterweight (1) has sufficient positive buoyancy), the bottom sections (8) of the intermediate buoys (9) are released and the floating platform (100) is ready to be moved to another location (or to port, for periodic maintenance operations).

[0157] Thus, the anchoring system for marine floating platforms (100), object of the present invention, is preferably formed by four or six anchoring lines (200), arranged radially around a common point (10) of the floating platform (100), each of which is formed by two anchoring sub-lines (200c, 200d) that can include the following elements:

- An inner pulley (2) (second rotary fastening means (2c) and, optionally, third rotary fastening means (2d)) and another outer pulley (first rotary fastening means (3)), located at the top of the anchoring line (200); they can be single (with a single sheave) or multiple (with several overlapping parallel sheaves);
- A central counterweight (1) common to all the anchor lines (200), located below the intersection point of all the anchor lines (200), with several ballast tanks or flood chambers, such that, when the ballast tanks of the central counterweight (1) are empty, it has a small positive buoyancy (e.g., less than 20% of the total volume of the counterweight (1)) and when all the ballast tanks of the central counterweight (1) are flooded, it has a large apparent (net) weight (e.g., greater than 15% of the total displacement of the floating platform (100));
- A flotation ring (700) or several flotation elements (500), with several ballast tanks or floodable chambers such that, when the ballast tanks of the flotation ring are empty, it has a small positive buoyancy (less than 20% of the total volume of the flotation ring) and when the ballast tanks of the flotation ring are fully flooded, it has a very large apparent weight (greater than 15% of the total displacement of the floating platform (100)).
- One anchoring ring common to all anchoring lines or multiple background weights (4) (one for each anchoring line (200)). Under the operation condition, the anchoring ring rests on the seabed (5) and performs the functions of the anchor of a conventional vessel, preventing wind, sea currents or waves from dragging the floating platform (100). In some applications, it can be replaced by several conventional anchors on the seabed (5) (piles, suction anchors, etc.), on which the cables of the anchoring system are fastened.
- An anchoring cable joining the central counterweight (1) to the anchoring ring (or to each of the bottom weights (4) or anchoring anchors) and resting on the inner pulley(s) (2) and on the outer pulley (first rotating fastening means (3)) of each anchoring line (200), divided virtually into three zones or sections: the central section (6) of the anchoring cable, running from the central counterweight (1) to the inner pulley (2) of that sub-line (200c, 200d), the intermediate section (7) of the anchoring cable, comprised between the inner pulley (2) and the outer pulley (first rotating fastening means (3)), and the bottom section (8) of the anchoring cable, running from the outer pulley (first rotating fastening means (3)) to the anchoring ring or bottom weight (4). As auxiliary elements, each anchoring line (200) may also include any of the following elements:
 - o One or more intermediate pulleys (rotary guide means (11)), which serve as support for the intermediate section (7) of the anchoring cable, sandwiched between the inner pulley (2) and the outer pulley (first rotary fixing means (3)), which serve as support or help to change the path of said section;
 - o An intermediate buoy (9) sandwiched in the bottom section (8) of the anchoring lines (200). If present, it is attached to the bottom weight (4) by another cable segment constituting a first portion of the bottom section (8);
 - o A projecting structural arm (12) for supporting the anchoring line (200), supported (or recessed) on the cover or on the hull or on the superstructure (20) of the floating platform (100), from which hang: the outer pulley (first rotary fixing means (3)), the inner pulley (2) and the support pulleys (rotary guiding means (11)) of the intermediate

section (7) (if any).

[0158] The anchoring system of the present invention may also include other auxiliary elements, common to conventional anchoring systems and which may assist in the installation/uninstallation maneuver of the floating platform (100) at its place of operation, such as winches, pinwheels, bollards or other elements typical of any traditional anchoring system.

[0159] Each anchoring line (200) has a direct subline (200d) and a cross subline (200c), whose inner sheave (second rotary fastening means (2c)) is located diametrically opposite the outer sheave (first rotary fastening means (3)). The anchoring system has an even number of protruding structural arms (12) and the corresponding anchoring lines (200) are arranged in diametrically opposed positions two by two.

[0160] In the design position, at rest and with calm sea, the bottom sections (8) of the anchoring cable of all the anchoring sublimes (200c, 200d) may be vertical (and parallel to each other).

[0161] Alternatively, the bottom section (8) of all the anchoring sublimes (200c, 200d) may be slightly divergent, i.e. the anchoring point of the anchoring cable on the bottom weights (4) is more horizontally spaced from the central counterweight (1) than the outer pulley (first rotary fastening means (3)).

[0162] The floating platform (100) may comprise the following elements:

- A hull or main structure (400) partially submerged with any geometry;
- A tower (13) supporting a marine wind turbine, located just above the hull of the floating platform (100);
- A complete marine wind turbine, whose nacelle (14) is installed above the corresponding tower (13);
- A central counterweight (1), located on the central axis (300) of symmetry of the floating platform (100), hanging from the central sections (6) of all the anchoring lines (200). Inside this there are a number of ballast tanks or flood chambers, which comply with the following restrictions: With all ballast tanks empty, the central counterweight (1) has a slightly positive buoyancy (it floats). With one or several of the tanks flooded, the buoyancy of the central counterweight (1) is slightly negative (it sinks). With all ballast tanks flooded, the apparent (net) weight of the central counterweight (1) is large (e.g., at least equal to 15% of the total weight of the floating platform (100));
- 4 or 6 protruding structural arms (12) for supporting the anchoring lines (200), arranged radially around the central axis (300) of symmetry of the hull of the floating platform (100). From the ends (121, 122) of each protruding structural arm (12) hang the outer pulleys (first rotary fixing means (3)) of the lines associated with each protruding structural arm (12). These pulleys can be single (with one sheave) or multiple (with several overlapping sheaves);
- The anchoring cable hangs from the two pulleys, inner pulley (2) and outer pulley (first rotary fixing means (3)) of each protruding structural arm (12). The central section (6) of the anchoring cable hangs from the inner pulley (2) and is fastened on the central counterweight (1). The bottom section (8) of the anchoring cable hangs from the outer pulley (first rotating fixing means (3)) and is fastened on the anchoring ring, on the bottom weights (4) or on anchors fixed on the bed or seabed (5). The anchor cable may be single (one cable) or multiple (several cables).

[0163] The hull or main structure (400) of the floating platform (100) has two main load conditions: a transport condition, in which all of its ballast tanks are empty and float freely with a characteristic waterline (21), and an operating condition, in which all of the anchoring lines (200) are connected to the seabed (5) and bear the net weight of the central counterweight (1). Some of its ballast tanks may be fully or partially filled so that their waterline (21) matches the design waterline (operating draught (22)).

[0164] According to a possible embodiment, the floating platform (100) comprises the following elements:

- Four cylindrical floats or flotation elements (500), separated from the central axis (300) of the floating platform (100), distributed uniformly throughout its surroundings. The waterline (21) in the ballast condition is located at half height of these floats, defining in them two volumes, the submerged area (15) and the emerging or emerged area (16) (the rest of the float). In ballast condition (transport of the floating platform (100)) the floatation surface provides all the stability required for transport operations. In the operating condition, the floats are fully submerged and do not provide stability;
- four legs or spokes (600), approximately prismatic in shape, inclined with respect to the vertical, which join each of the floats or floating elements (500) with the rest of the floating platform (100). In the ballast condition they are totally out of the water, but in the operating condition, they have a submerged part or submerged radio zone in the operating condition (17) and another never submerged part or zone (18) above the waterline or the operating draught (22). In the operation (or design) condition the floating platform (100) has no stability *per se*;

EP 4 353 577 B1

- four protruding structural arms (12) arranged radially, approximately horizontal, which serve to support the sheaves of the anchoring system;
- A reinforced and resistant structural ring (19), at the base of the superstructure (20), in which the legs or spokes (600) that go to the floats and the protruding structural arms (12) that support the anchoring lines (200) are fastened;
- The superstructure (20) on the reinforced structural ring (19), which serves as the base for the tower (13) of the wind turbine and inside which the electrical equipment of the wind turbine or the electrical connection systems with the rest of the wind turbines of the wind farm can be located;
- The tower (13) and the wind turbine.

[0165] According to another possible embodiment, the floating platform (100) comprises the following elements:

- A vertical axis cylindrical hull or main structure (400), with three distinct zones: the lower part or submerged zone (15), which is submerged in the condition of ballast, the upper part or never submerged zone (18) that is always above the flotation or draught of operation (22) and the intermediate area or emerging or emerged zone (16), which is between the ballast waterline and the design waterline;
- four protruding structural arms (12) supporting the sheaves of the anchoring system, fastened to the upper part or never submerged area (18) of the hull, where an anchoring line (200) hangs from each of the protruding structural arms (12);
- A mooring ring grouping the four bottom weights (4), which provides the necessary stability to the floating platform (100) (according to this embodiment with cylindrical hull) during the transport and installation operations, and is incompatible with the use of fixed anchors to the seabed (5) since it is not stable on its own.

[0166] According to another alternative embodiment, the floating platform (100) comprises the following elements: four arms (and therefore four anchoring lines and four legs). The main and characteristic elements of its geometry are:

- The submerged hull is formed by a slender flotation ring (700), of large diameter (compared to its height or thickness), which in the ballast condition has two parts, a submerged area (15) that is always submerged and another emerging or emerged area (16), which in the ballast condition is above the waterline (21), but which in operation is totally submerged;
- Four legs or spokes (600), inclined with respect to the vertical, uniformly distributed, joining the submerged hull with the resistant structural ring (19);
- Four protruding structural arms (12) that hold the pulleys and the anchoring lines (200) of the anchoring system; these four protruding structural arms (12) are fastened on the submerged hull and are also quite inclined with respect to the vertical;
- The central sections (6) of all the anchoring sub-lines (200c, 200d) go from the inner pulleys (2) to the counterweight (1), passing through the inner hollow of the flotation ring (700) that forms the submerged hull or main structure (400).

[0167] For those floating platforms (100) that are stable *per se* in the ballast condition, the following simplified sequence of installation phases can be followed:

- The platform (100) is built by any conventional shipbuilding procedure and launched (thrown into the water). The central counterweight (1) is also built, all its ballast tanks are emptied and it is launched;
- All the equipment on board is finished, including the tower (13) and the wind turbine, the platform now floats in its ballast condition and is perfectly stable with all the empty ballast tanks;
- The bottom anchors of the floating platform (100) are fixed at their destination (by means of piles, bottom weights (4), an anchoring ring or any other conventional anchoring system), the lower sections of the bottom section (8) are installed and they are hooked to an intermediate buoy (9), which has a buoyancy slightly higher than the own weight of the cables that join it to the bottom; the buoy (9) remains floating at half height, all at the same depth;

EP 4 353 577 B1

- The floating platform (100) and counterweight (1) are moved to their destination, by using a conventional tugboat. The central counterweight (1) is located below the axis of the floating platform (100);
- The cables of all the anchoring sublimes (200c, 200d) are connected both to the central counterweight (1) and to the intermediate buoys (9); at this time the cables are loose, since they are somewhat longer than the actual distances between the counterweight (1), the outer pulleys (first rotary fixing means (3)) and the intermediate buoys (9);
- The floating platform (100) is dragged sideways (with the tug), until the cables of the anchoring system are slightly tensioned;
- The counterweight ballast tanks (1) are flooded very slowly; when the counterweight (1) reaches an apparent density equal to that of sea water, it begins to sink, dragging the floating platform (100) towards its design position;
- As the apparent density of the counterweight 1 increases, the tension in the cables increases and the floating platform 100 begins to sink slowly. When all the ballast tanks of the central counterweight (1) are full, the floating platform (100) is almost in its design or operating draught (22);
- The draught of the floating platform (100) is corrected by totally or partially filling any of the ballast tanks or flood chambers of the floating platform (100) (of the floating elements (500) or of the floating ring (700));
- The floating platform (100) is electrically connected to the rest of the wind farm.

[0168] At this time, the floating platform (100) is fully operational.

[0169] For those floating platforms (100) that are stable *per se* in the ballast condition, the following simplified sequence of uninstallation phases can be followed (inverse to the sequence of installation phases described above):

- The floating platform (100) is electrically disconnected from the rest of the wind farm;
- The ballast tanks or flood chambers of the floating platform (100) (of the floating elements (500) or of the floating ring (700)) are emptied;
- The ballast tanks or flood chambers of the central counterweight (1) are emptied by means of hydraulic pumps or by injecting compressed air into them;
- As the counterweight (1) loses net weight, the cables of the anchoring lines (200) become loose; the floating platform (100) slowly rises and the counterweight (1) approaches the surface;
- When the submerged floats or flotation elements 500 of the floating platform 100 reach the sea surface, the floating platform 100 regains all its stability and no longer needs the stability provided by the anchoring system cables;
- A tug is coupled to the floating platform (100) and a lateral force is exerted that tends to separate the floating platform (100) from its equilibrium position;
- When the counterweight (1) reaches the surface, the floating platform (100) has moved laterally; then, the ballast tanks of the counterweight (1) are emptied until it acquires the full buoyancy for its transport condition;
- The towing cable is released from the tug and then the hooks of all the central sections (6) of the counterweight (1) and of all the bottom sections (8) of the intermediate buoy (9) are released.

[0170] At this time, both the floating platform (100) and the central counterweight (1) float by themselves, with all the stability they need and are ready to be moved to another location or to port for maintenance operations.

Claims

1. Anchoring system comprising a floating platform (100) and at least one pair of anchoring lines (200), configured to fix or anchor the floating platform (100) to the seabed (5) by means of at least one bottom section (8) of each anchoring line (200), wherein each anchoring line (200) also comprises a central section (6) attached to a counterweight (1),

wherein each pair of anchoring lines (200) comprises two anchoring lines (200) arranged in a plane that passes through a central axis (300) of the floating platform (100), and located respectively on one side and the other of the central axis (300) of the floating platform (100), wherein the anchoring system comprises at least one first rotating fixing means (3) for each anchoring line (200), where each first rotating fixing means (3) is fixed to a first point of the floating platform (100) and is configured to fix each anchoring line (200) to the floating platform (100) at said first point of the floating platform (100), allowing the sliding of the anchoring line (200) along said first rotary fixing means (3), **characterized in that:**

- each anchoring line (200) comprises at least one direct subline (200d) and one cross subline (200c), each comprising its own anchoring cable or chain, wherein each direct subline (200d) runs from the first rotary fastening means (3) to the counterweight (1) without passing through the central axis (300) of the floating platform (100), and wherein each cross subline (200c) runs from the first rotary fastening means (3) to the counterweight (1) through the central axis (300) of the floating platform (100);

- wherein the system comprises at least one second rotary fastening means (2c) for each anchoring line (200), wherein each second rotary fastening means (2c) is fixed to a second point of the floating platform (100) and is configured to fasten each cross subline (200c) of each anchoring line (200) to the floating platform (100) at said second point of the floating platform (100), allowing sliding of the cross subline (200c) along said second rotary fastening means (2c), so that each cross subline (200c) runs from the first rotary fastening means (3) to the counterweight (1) first through the central axis (300) of the floating platform (100) and secondly sliding along the second rotary fastening means (2c).

2. Anchoring system according to claim 1, **characterized in that** the floating platform (100) comprises a pair of protruding structural arms (12) for each pair of anchoring lines (200), wherein each pair of protruding structural arms (12) comprises a first arm (12a) and a second arm (12b) located symmetrically with respect to the central axis (300) of the floating platform (100), wherein each protruding structural arm (12) is attached to a main structure (400) of the floating platform (100), wherein each protruding structural arm (12) runs radially from a first end (121) attached to the main structure (400) of the floating platform (1) to a second end (122) projected outwardly of the floating platform (1), wherein the at least one first rotating fixing means (3) is fixed to the floating platform (100) in correspondence with the second end (122) of the first arm (12a), and wherein the at least one second rotating fixing means (2) is fixed to the floating platform (100) at a point located in correspondence with the second arm (12b).
3. Anchoring system according to claim 2, **characterised in that** the main structure (400) of the floating platform (100) comprises a geometry in the form of a cylindrical, conical or pyramidal shaft.
4. Anchoring system according to claim 3, **characterized in that** it comprises a plurality of spokes (600) connected to the main structure (400), where at each free end of each spoke (600) there is a flotation element (500).
5. Anchoring system according to claim 4, **characterized in that** the flotation elements (500) comprise at least one floodable chamber.
6. Anchoring system according to claim 3, **characterized in that** the main structure (400) comprises at least one flotation element (500).
7. Anchoring system according to claim 6, **characterized in that** the at least one flotation element (500) comprises at least one floodable chamber.
8. Anchoring system according to claim 2, **characterised in that** the main structure (400) of the floating platform (100) comprises a ring-shaped geometry, said ring being joined by means of spokes (600) to a cylindrical, conical or pyramidal shaft.
9. Anchoring system according to claim 8, **characterized in that** the main structure (400) constitutes a flotation ring (700).
10. Anchoring system according to claim 9, **characterized in that** the flotation ring (700) comprises at least one floodable chamber.
11. Anchoring system according to any one of the preceding claims, **characterized in that** it comprises at least a third rotary fixing means (2d) for each anchoring line (200), wherein each third rotary fixing means (2d) is fixed to a third

point of the floating platform (100) and is configured to attach each direct subline (200d) of each anchoring line (200) to the floating platform (100) at said third point of the floating platform (100) allowing the sliding of the direct subline (200d) along said third rotary fixing means (2d), so that each direct subline (200d) runs from the first rotary fixing means (3) to the counterweight (1) passing through and sliding along the third rotary fixing means (2d).

5
12. Anchoring system according to any one of the preceding claims, **characterized in that** it comprises at least one rotary guiding means (11) for each anchoring line (200), wherein each rotary guiding means (11) is attached to a fourth point of the floating platform (100) and is configured to guide the course of the cross-subline (200c) of each anchoring line (200) allowing the sliding of the cross-subline (200c) by said rotary guiding means (11), so that each cross-subline (200c) runs between the first rotary fixing means (3) and the second rotary fixing means (2c) passing through and sliding along the rotary guiding means (11).

10
13. Anchoring system according to any of the preceding claims, **characterized in that** each bottom section (8) of each anchoring line (200) comprises a buoy (9) that divides the bottom section (8) into a first portion that runs between the seabed (5) and the buoy (9) and a second portion that runs between the buoy (9) and the at least one first rotary fixing means (3).

15
14. Anchoring system according to any one of the preceding claims, **characterized in that** the counterweight (1) comprises at least one floodable chamber.

20
15. Method of installing a floating platform (1) using an anchoring system according to claim 14, **characterized in that** it comprises:

- 25
- positioning and/or anchoring to the seabed (5), under a place of installation of the floating platform (100), at least one anchor and/or at least one bottom weight (4), and/or at least one anchoring ring and/or a set of piles;
 - moving the floating platform (100) and the counterweight (1) to its place of installation, where the at least one floodable chamber is located without flooding;
 - attaching a free end of the bottom section (8) of each anchoring line (200):

- 30
- o to the at least one anchor and/or the at least one bottom weight (4), and/or the at least one anchoring ring and/or the set of piles, or;
 - o to a buoy (9) previously joined by a first portion of the bottom section (8) of the anchoring line (200) to the at least one anchor and/or the at least one bottom weight (4), and/or to the at least one anchoring ring and/or to the set of piles;

- 35
- fixing a free end of the central section (6) of each anchoring line (200) to the counterweight (1);
 - dragging the floating platform (100) sideways until the anchoring lines (200) are tensioned, and;
 - flooding the at least one flotation chamber.

40
Patentansprüche

45
1. Verankerungssystem, das eine schwimmende Plattform (100) und mindestens ein Paar Verankerungsleinen (200) umfasst, die so konfiguriert sind, dass sie die schwimmende Plattform (100) mit Hilfe mindestens eines unteren Abschnitts (8) jeder Verankerungsleine (200) am Meeresboden (5) befestigen oder verankern, wobei jede Verankerungsleine (200) auch einen mittleren Abschnitt (6) umfasst, der an einem Gegengewicht (1) befestigt ist), wobei jedes Paar von Verankerungsleinen (200) zwei Verankerungsleinen (200) umfasst, die in einer Ebene angeordnet sind, die durch eine Mittelachse (300) der schwimmenden Plattform (100) verläuft, und die sich jeweils auf einer Seite und der anderen Seite der Mittelachse (300) der schwimmenden Plattform (100) befinden, wobei das Verankerungssystem mindestens ein erstes drehbares Befestigungsmittel (3) für jede Verankerungsleine, wobei jedes erste drehbare Befestigungsmittel (3) an einem ersten Punkt der schwimmenden Plattform (100) befestigt und so konfiguriert ist, dass es jede Verankerungsleine (200) an der schwimmenden Plattform (100) an dem ersten Punkt der schwimmenden Plattform (100) befestigt, wobei es das Gleiten der Verankerungsleine (200) entlang des ersten drehbaren Befestigungsmittels (3) ermöglicht, **dadurch gekennzeichnet, dass:**

- 55
- jede Verankerungsleine (200) mindestens eine direkte Unterleine (200d) und eine Querunterleine (200c) umfasst, die jeweils ihr eigenes Verankerungskabel oder ihre eigene Verankerungskette umfassen, wobei jede direkte Unterleine (200d) von dem ersten drehbaren Befestigungsmittel (3) zum Gegengewicht (1) verläuft, ohne

durch die Mittelachse (300) der schwimmenden Plattform (100) zu verlaufen, und wobei jede Querunterleine (200c) von dem ersten drehbaren Befestigungsmittel (3) zum Gegengewicht (1) durch die Mittelachse (300) der schwimmenden Plattform (100) verläuft;

- wobei das System mindestens ein zweites drehbares Befestigungsmittel (2c) für jede Verankerungsleine (200) umfasst, wobei jedes zweite drehbare Befestigungsmittel (2c) an einem zweiten Punkt der schwimmenden Plattform (100) befestigt ist und so konfiguriert ist, dass es jede Querunterleine (200c) jeder Verankerungsleine (200) an der schwimmenden Plattform (100) an dem zweiten Punkt der schwimmenden Plattform (100) befestigt, wodurch ein Gleiten der Querunterleine (200c) entlang des zweiten drehbaren Befestigungsmittels (2c) ermöglicht wird, sodass jede Querunterleine (200c) von dem ersten drehbaren Befestigungsmittel (3) zum Gegengewicht (1) verläuft, und zwar erstens durch die Mittelachse (300) der schwimmenden Plattform (100) und zweitens gleitend entlang des zweiten drehbaren Befestigungsmittels (2c).

2. Verankerungssystem nach Anspruch 1, **dadurch gekennzeichnet, dass** die schwimmende Plattform (100) ein Paar vorstehender Strukturarme (12) für jedes Paar Verankerungsleinen (200) umfasst, wobei jedes Paar vorstehender Strukturarme (12) einen ersten Arm (12a) und einen zweiten Arm (12b) umfasst, die symmetrisch in Bezug auf die Mittelachse (300) der der schwimmenden Plattform (100) angeordnet ist, wobei jeder vorstehende Strukturarm (12) an einer Hauptstruktur (400) der schwimmenden Plattform (100) angebracht ist, wobei jeder vorstehende Strukturarm (12) radial von einem ersten Ende (121), das an der Hauptstruktur (400) der schwimmenden Plattform (1) angebracht ist, zu einem zweiten Ende (122) verläuft, das nach außen der schwimmenden Plattform (1) vorsteht, wobei das mindestens eine erste drehbare Befestigungsmittel (3) an der schwimmenden Plattform (100) in Übereinstimmung mit dem zweiten Ende (122) des ersten Arms (12a) befestigt ist und wobei das mindestens eine zweite drehbare Befestigungsmittel (2) an der schwimmenden Plattform (100) an einem Punkt befestigt ist, der sich in Übereinstimmung mit dem zweiten Arm (12b) befindet.
3. Verankerungssystem nach Anspruch 2, **dadurch gekennzeichnet, dass** die Hauptstruktur (400) der schwimmenden Plattform (100) eine Geometrie in Form eines zylindrischen, konischen oder pyramidenförmigen Schafts aufweist.
4. Verankerungssystem nach Anspruch 3, **dadurch gekennzeichnet, dass** es eine Vielzahl von Speichen (600) umfasst, die mit der Hauptstruktur (400) verbunden sind, wobei sich an jedem freien Ende jeder Speiche (600) ein Schwimmkörper (500) befindet.
5. Verankerungssystem nach Anspruch 4, **dadurch gekennzeichnet, dass** die Schwimmkörper (500) mindestens eine flutbare Kammer umfassen.
6. Verankerungssystem nach Anspruch 3, **dadurch gekennzeichnet, dass** die Hauptstruktur (400) mindestens einen Schwimmkörper (500) umfasst.
7. Verankerungssystem nach Anspruch 6, **dadurch gekennzeichnet, dass** der mindestens eine Schwimmkörper (500) mindestens eine flutbare Kammer umfasst.
8. Verankerungssystem nach Anspruch 2, **dadurch gekennzeichnet, dass** die Hauptstruktur (400) der schwimmenden Plattform (100) eine ringförmige Geometrie aufweist, wobei der Ring mittels Speichen (600) mit einem zylindrischen, konischen oder pyramidenförmigen Schaft verbunden ist.
9. Verankerungssystem nach Anspruch 8, **dadurch gekennzeichnet, dass** die Hauptstruktur (400) einen Schwimmring (700) bildet.
10. Verankerungssystem nach Anspruch 9, **dadurch gekennzeichnet, dass** der Schwimmring (700) mindestens eine flutbare Kammer umfasst.
11. Verankerungssystem nach einem der vorhergehenden Ansprüche, **dadurch gekennzeichnet, dass** es mindestens ein drittes drehbares Befestigungsmittel (2d) für jede Verankerungsleine (200) umfasst, wobei jedes dritte drehbare Befestigungsmittel (2d) an einem dritten Punkt der schwimmenden Plattform (100) befestigt und so konfiguriert ist, dass es jede direkte Unterleine (200d) jeder Verankerungsleine (200) an der schwimmenden Plattform (100) an dem dritten Punkt der schwimmenden Plattform (100) zu befestigen, wobei das Gleiten der direkten Unterleine (200d) entlang des dritten drehbaren Befestigungsmittels (2d) ermöglicht wird, so dass jede direkte Unterleine (200d) von dem ersten drehbaren Befestigungsmittel (3) zu dem Gegengewicht (1) verläuft und dabei durch das dritte drehbare

Befestigungsmittel (2d) hindurchgeht und entlang diesem gleitet.

12. Verankerungssystem nach einem der vorhergehenden Ansprüche, **dadurch gekennzeichnet, dass** es mindestens ein Drehführungsmittel (11) für jede Verankerungsleine (200) umfasst, wobei jedes Drehführungsmittel (11) an einem vierten Punkt der schwimmenden Plattform (100) angebracht und so konfiguriert ist, dass es den Verlauf der Querunterleine (200c) jeder Verankerungsleine (200) zu führen, wobei das Gleiten der Querunterleine (200c) durch die Drehführungseinrichtung (11) ermöglicht wird, so dass jede Quer-Unterleine (200c) zwischen des ersten drehbaren Befestigungsmittels (3) und des zweiten drehbaren Befestigungsmittels (2c) verläuft und dabei durch die Drehführungseinrichtung (11) hindurchgeht und entlang dieser gleitet.

13. Verankerungssystem nach einem der vorhergehenden Ansprüche, **dadurch gekennzeichnet, dass** jeder untere Abschnitt (8) jeder Verankerungsleine (200) eine Boje (9) umfasst, die den unteren Abschnitt (8) in einen ersten Abschnitt, der zwischen dem Meeresboden (5) und der Boje (9) verläuft, und einen zweiten Abschnitt, der zwischen der Boje (9) und dem mindestens einen ersten drehbaren Befestigungsmittel (3) verläuft, unterteilt.

14. Verankerungssystem nach einem der vorhergehenden Ansprüche, **dadurch gekennzeichnet, dass** das Gegengewicht (1) mindestens eine flutbare Kammer umfasst.

15. Verfahren zur Installation einer schwimmenden Plattform (1) unter Verwendung eines Verankerungssystems nach Anspruch 14, **dadurch gekennzeichnet, dass** es Folgendes umfasst:

- Positionierung und/oder Verankerung am Meeresboden (5) unter einem Ort der Installation der schwimmenden Plattform (100), mindestens ein Anker und/oder mindestens ein Bodengewicht (4) und/oder mindestens ein Verankerungsring und/oder ein Satz Pfähle;

- Bewegen der schwimmenden Plattform (100) und des Gegengewichts (1) an ihren Ort der Installation, wo sich die mindestens eine flutbare Kammer befindet, ohne geflutet zu werden;

- Anbringen eines freien Endes des unteren Abschnitts (8) jeder Verankerungsleine (200):

- o an dem mindestens einen Anker und/oder dem mindestens einen Bodengewicht (4) und/oder dem mindestens einen Verankerungsring und/oder dem Satz von Pfählen oder;

- o mit einer Boje (9), die zuvor durch einen ersten Abschnitt des unteren Abschnitts (8) der Verankerungsleine (200) mit dem mindestens einen Anker und/oder dem mindestens einen Bodengewicht (4) und/oder mit dem mindestens einen Verankerungsring und/oder dem Satz von Pfählen verbunden war;

- Befestigen eines freien Endes des mittleren Abschnitts (6) jeder Verankerungsleine (200) an dem Gegengewicht (1);

- seitliches Ziehen der schwimmenden Plattform (100), bis die Verankerungsleinen (200) gespannt sind, und
- Fluten der mindestens einen flutbaren Kammer.

Revendications

1. Système d'ancrage comprenant une plate-forme flottante (100) et au moins une paire de lignes d'ancrage (200), configurée pour fixer ou ancrer la plate-forme flottante (100) au fond marin (5) au moyen d'au moins une section inférieure (8) de chaque ligne d'ancrage (200), dans lequel chaque ligne d'ancrage (200) comprend également une section centrale (6) attachée à un contrepoids (1), dans lequel chaque paire de lignes d'ancrage (200) comprend deux lignes d'ancrage (200) disposées dans un plan qui passe par un axe central (300) de la plate-forme flottante (100), et situées respectivement d'un côté et de l'autre de l'axe central (300) de la plate-forme flottante (100), dans lequel le système d'ancrage comprend au moins un premier moyen de fixation rotatif (3) pour chaque ligne d'ancrage (200), chaque premier moyen de fixation rotatif (3) étant fixé à un premier point de la plate-forme flottante (100) et étant configuré pour fixer chaque ligne d'ancrage (200) à la plate-forme flottante (100) au niveau dudit premier point de la plate-forme flottante (100), ce qui permet le coulissement de la ligne d'ancrage (200) le long dudit premier moyen de fixation rotatif (3), **caractérisé en ce que** :

- chaque ligne d'ancrage (200) comprend au moins une sous-ligne directe (200d) et une sous-ligne transversale (200c), chacune comprenant son propre câble ou sa propre chaîne d'ancrage, chaque sous-ligne directe (200d) s'étendant du premier moyen de fixation rotatif (3) au contrepoids (1) sans passer par l'axe central (300) de la plate-forme flottante (100), et chaque sous-ligne transversale (200c) s'étendant du premier moyen de fixation

rotatif (3) au contrepoids (1) par l'axe central (300) de la plate-forme flottante (100) ;

- le système comprend au moins un second moyen de fixation rotatif (2c) pour chaque ligne d'ancrage (200), chaque second moyen de fixation rotatif (2c) étant fixé à un second point de la plate-forme flottante (100) et étant configuré pour fixer chaque sous-ligne transversale (200c) de chaque ligne d'ancrage (200) à la plate-forme flottante (100) au niveau dudit second point de la plate-forme flottante (100), ce qui permet le coulisement de la sous-ligne transversale (200c) le long dudit second moyen de fixation rotatif (2c), de sorte que chaque sous-ligne transversale (200c) s'étend du premier moyen de fixation rotatif (3) au contrepoids (1) d'abord par l'axe central (300) de la plate-forme flottante (100) et ensuite par coulisement le long du second moyen de fixation rotatif (2c).

- 5
- 10 **2.** Système d'ancrage selon la revendication 1, **caractérisé en ce que** la plate-forme flottante (100) comprend une paire de bras structurels saillants (12) pour chaque paire de lignes d'ancrage (200), chaque paire de bras structurels saillants (12) comprenant un premier bras (12a) et un second bras (12b) situés symétriquement par rapport à l'axe central (300) de la plate-forme flottante (100), chaque bras structurel saillant (12) étant fixé à une structure principale (400) de la plate-forme flottante (100), chaque bras structurel saillant (12) s'étendant radialement d'une première extrémité (121) fixée à la structure principale (400) de la plate-forme flottante (100) à une seconde extrémité (122) faisant saillie vers l'extérieur de la plate-forme flottante (100), l'au moins un premier moyen de fixation rotatif (3) étant fixé à la plate-forme flottante (100) en correspondance avec la seconde extrémité (122) du premier bras (12a), et l'au moins un second moyen de fixation rotatif (2) étant fixé à la plate-forme flottante (100) en un point situé en correspondance avec le second bras (12b).
- 15
- 20 **3.** Système d'ancrage selon la revendication 2, **caractérisé en ce que** la structure principale (400) de la plate-forme flottante (100) comprend une géométrie en forme d'arbre cylindrique, conique ou pyramidal.
- 25 **4.** Système d'ancrage selon la revendication 3, **caractérisé en ce qu'il** comprend une pluralité de rayons (600) reliés à la structure principale (400), un élément de flottaison (500) se trouvant à chaque extrémité libre de chaque rayon (600).
- 5.** Système d'ancrage selon la revendication 4, **caractérisé en ce que** les éléments de flottaison (500) comprennent au moins une chambre inondable.
- 30 **6.** Système d'ancrage selon la revendication 3, **caractérisé en ce que** la structure principale (400) comprend au moins un élément de flottaison (500).
- 7.** Système d'ancrage selon la revendication 6, **caractérisé en ce que** l'au moins un élément de flottaison (500) comprend au moins une chambre inondable.
- 35 **8.** Système d'ancrage selon la revendication 2, **caractérisé en ce que** la structure principale (400) de la plate-forme flottante (100) comprend une géométrie en forme d'anneau, ledit anneau étant relié au moyen de rayons (600) à un arbre cylindrique, conique ou pyramidal.
- 40 **9.** Système d'ancrage selon la revendication 8, **caractérisé en ce que** la structure principale (400) constitue un anneau de flottaison (700).
- 10.** Système d'ancrage selon la revendication 9, **caractérisé en ce que** l'anneau de flottaison (700) comprend au moins une chambre inondable.
- 45 **11.** Système d'ancrage selon l'une quelconque des revendications précédentes, **caractérisé en ce qu'il** comprend au moins un troisième moyen de fixation rotatif (2d) pour chaque ligne d'ancrage (200), chaque troisième moyen de fixation rotatif (2d) étant fixé à un troisième point de la plate-forme flottante (100) et étant configuré pour attacher chaque sous-ligne directe (200d) de chaque ligne d'ancrage (200) à la plate-forme flottante (100) au niveau dudit troisième point de la plate-forme flottante (100), ce qui permet le coulisement de la sous-ligne directe (200d) le long dudit troisième moyen de fixation rotatif (2d), de sorte que chaque sous-ligne directe (200d) s'étend du premier moyen de fixation rotatif (3) au contrepoids (1) en passant par et en coulisant le long du troisième moyen de fixation rotatif (2d).
- 50
- 55 **12.** Système d'ancrage selon l'une quelconque des revendications précédentes, **caractérisé en ce qu'il** comprend au moins un moyen de guidage rotatif (11) pour chaque ligne d'ancrage (200), chaque moyen de guidage rotatif (11) étant fixé à un quatrième point de la plate-forme flottante (100) et étant configuré pour guider le parcours de la sous-ligne transversale (200c) de chaque ligne d'ancrage (200), ce qui permet le coulisement de la sous-ligne transversale

(200c) par ledit moyen de guidage rotatif (11), de sorte que chaque sous-ligne transversale (200c) s'étend entre le premier moyen de fixation rotatif (3) et le second moyen de fixation rotatif (2c) en passant par et en couissant le long du moyen de guidage rotatif (11).

5 **13.** Système d'ancrage selon l'une quelconque des revendications précédentes, **caractérisé en ce que** chaque section inférieure (8) de chaque ligne d'ancrage (200) comprend une bouée (9) qui divise la section inférieure (8) en une première partie qui s'étend entre le fond marin (5) et la bouée (9) et une seconde partie qui s'étend entre la bouée (9) et l'au moins un premier moyen de fixation rotatif (3).

10 **14.** Système d'ancrage selon l'une quelconque des revendications précédentes, **caractérisé en ce que** le contrepoids (1) comprend au moins une chambre inondable.

15. Procédé d'installation d'une plate-forme flottante (100) utilisant un système d'ancrage selon la revendication 14, **caractérisé en ce qu'il** consiste à :

- 15
- positionner et/ou ancrer au fond marin (5), sous un lieu d'installation de la plate-forme flottante (100), au moins une ancre et/ou au moins un poids inférieur (4) et/ou au moins un anneau d'ancrage et/ou un ensemble de pieux ;
 - déplacer la plate-forme flottante (100) et le contrepoids (1) vers leur lieu d'installation, l'au moins une chambre inondable étant située sans inondation ;
 - 20 - fixer une extrémité libre de la section inférieure (8) de chaque ligne d'ancrage (200) :

oà l'au moins une ancre et/ou à l'au moins un poids inférieur (4) et/ou à l'au moins un anneau d'ancrage et/ou à l'ensemble de pieux, ou ;

25 oà une bouée (9) précédemment reliée par une première partie de la section inférieure (8) de la ligne d'ancrage (200) à l'au moins une ancre et/ou à l'au moins un poids inférieur (4) et/ou à l'au moins un anneau d'ancrage et/ou à l'ensemble de pieux ;

- 30
- fixer une extrémité libre de la section centrale (6) de chaque ligne d'ancrage (200) au contrepoids (1) ;
 - faire glisser la plate-forme flottante (100) sur le côté jusqu'à ce que les lignes d'ancrage (200) soient tendues, et ;
 - inonder l'au moins une chambre de flottaison.

35

40

45

50

55

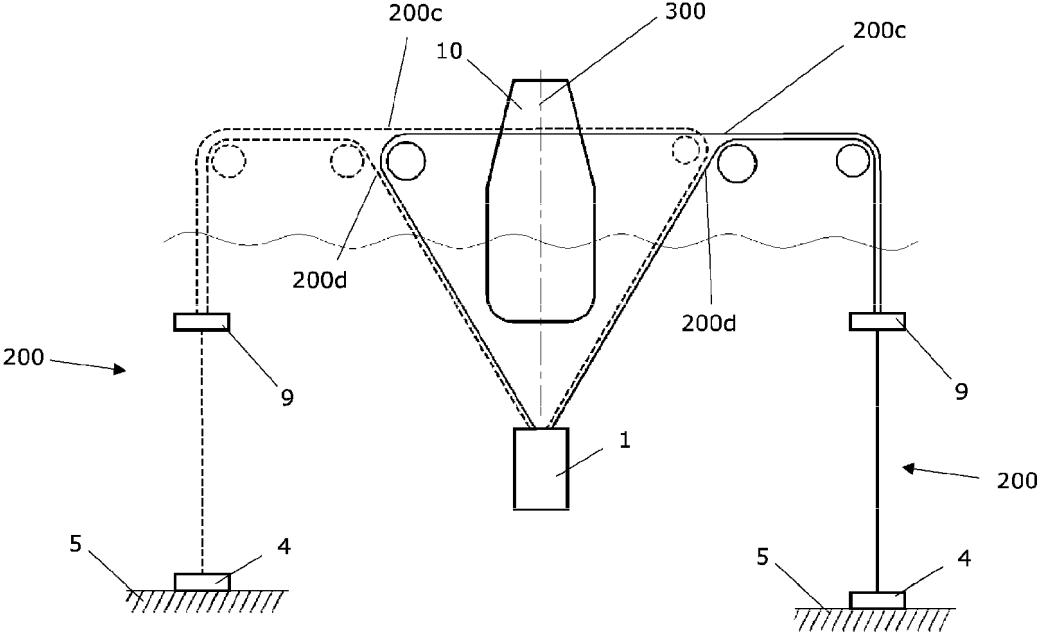

FIG. 1

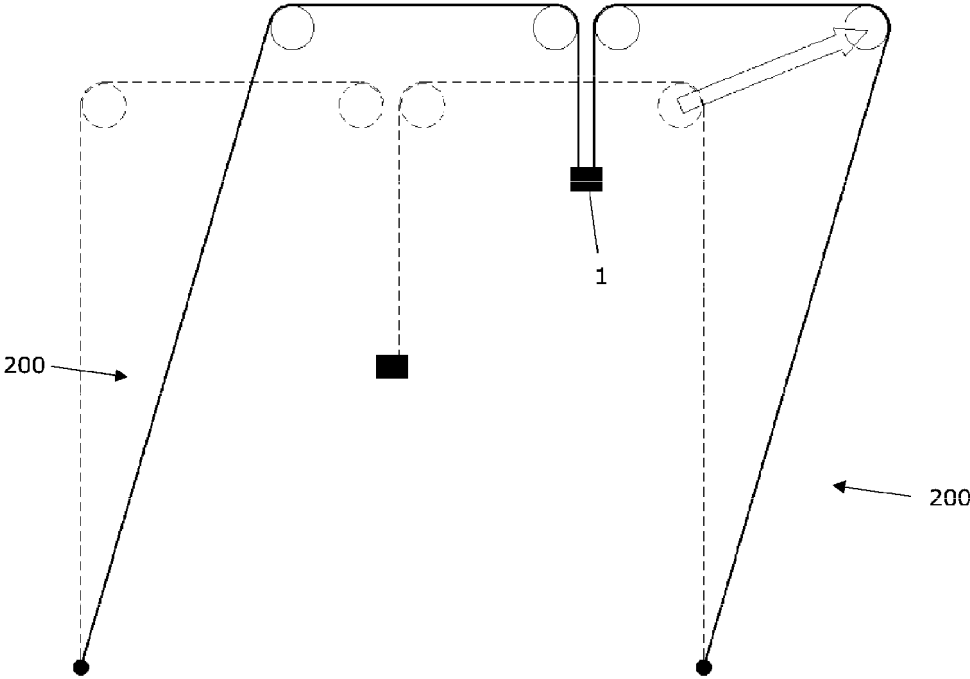

FIG. 2

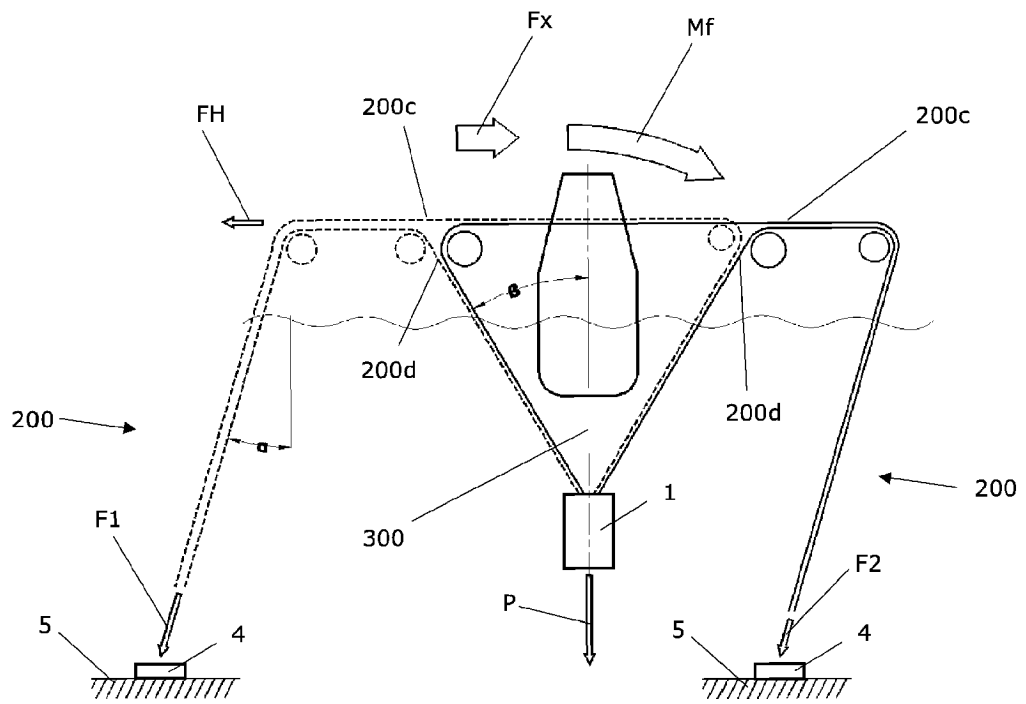

FIG. 3

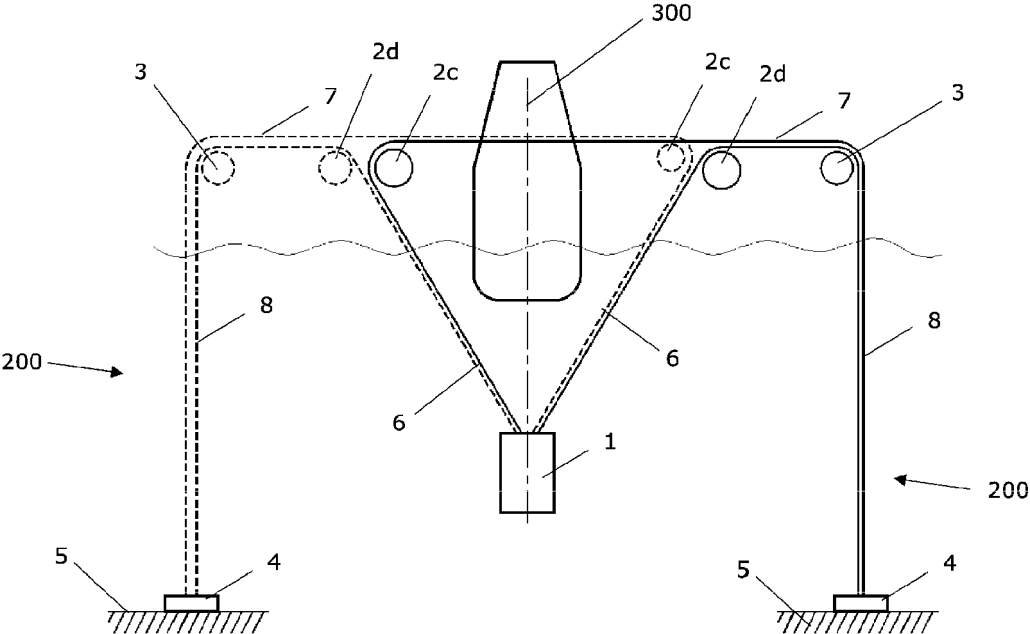

FIG. 4

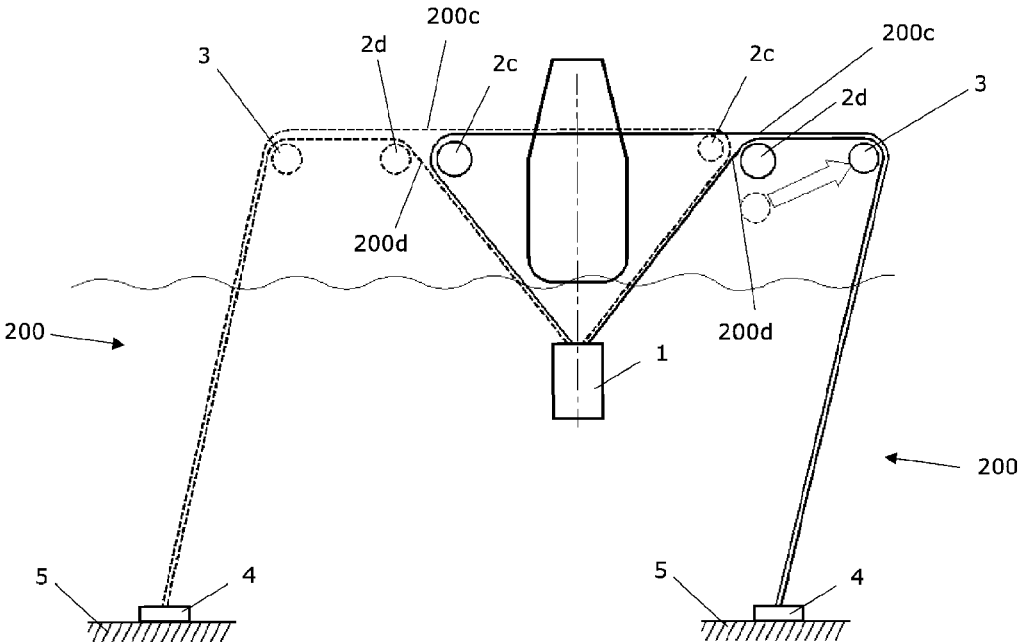

FIG. 5

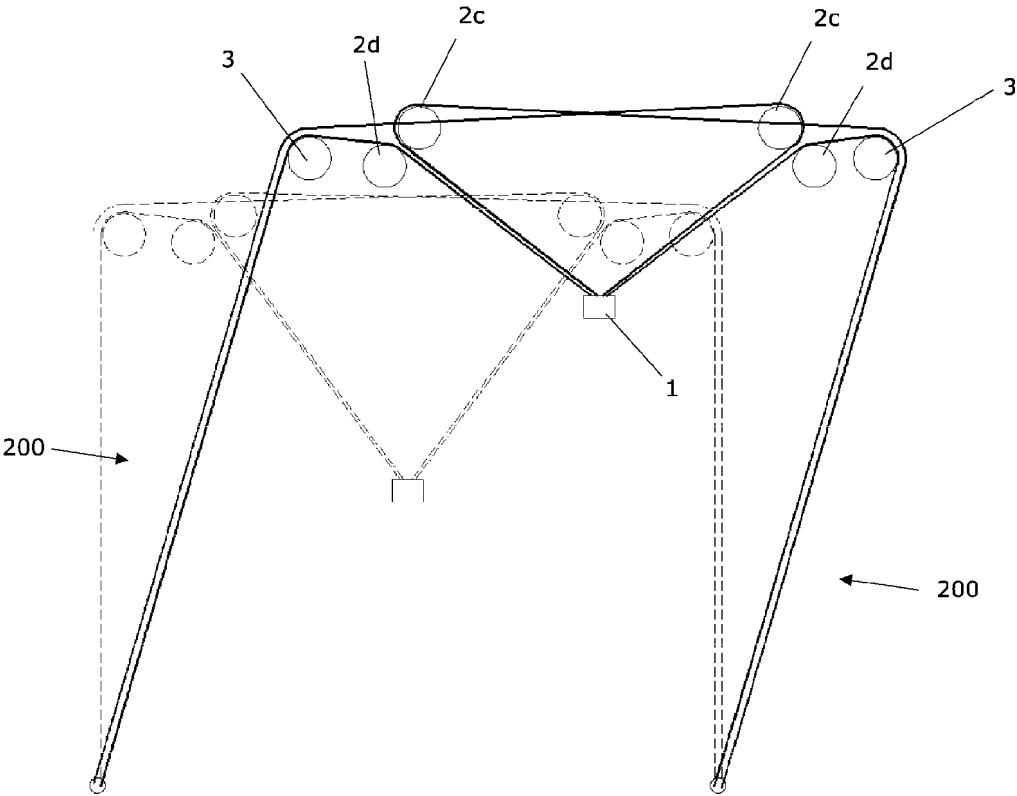

FIG. 6

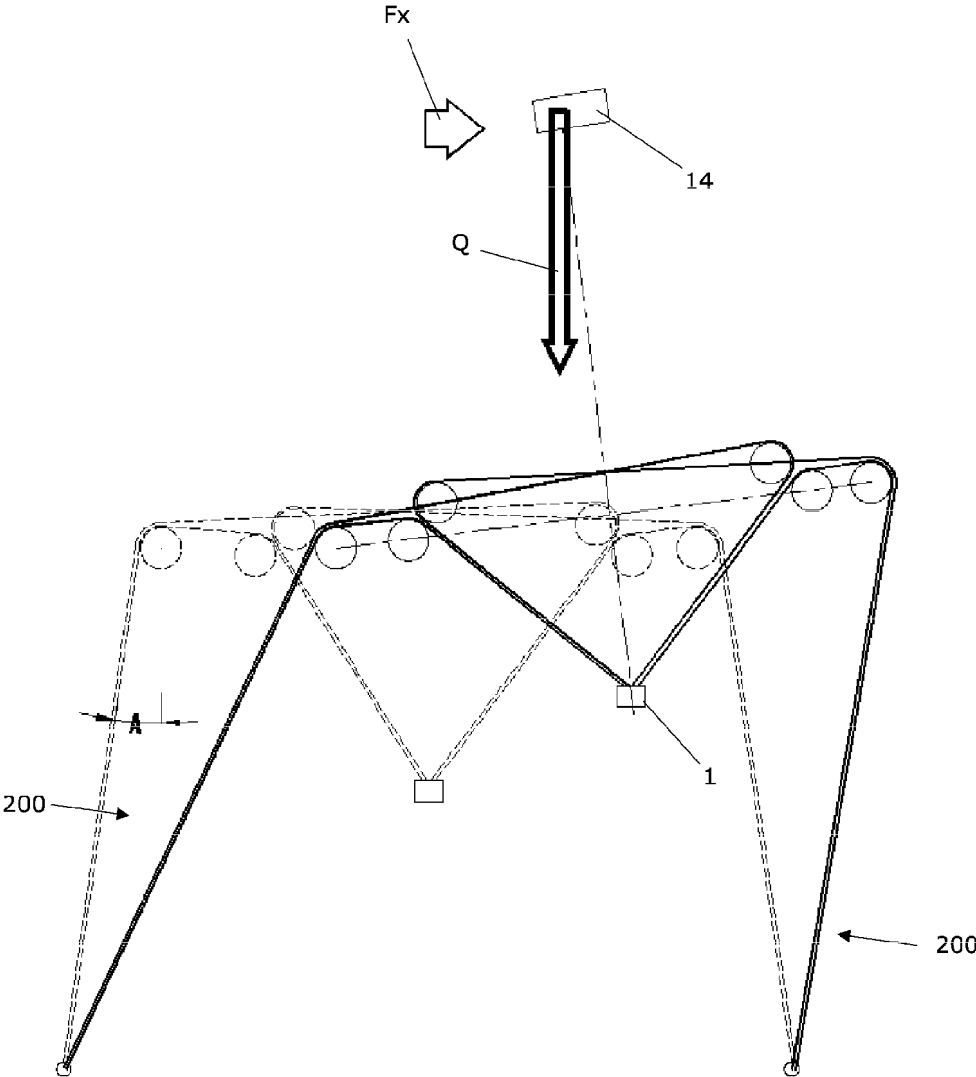

FIG. 7

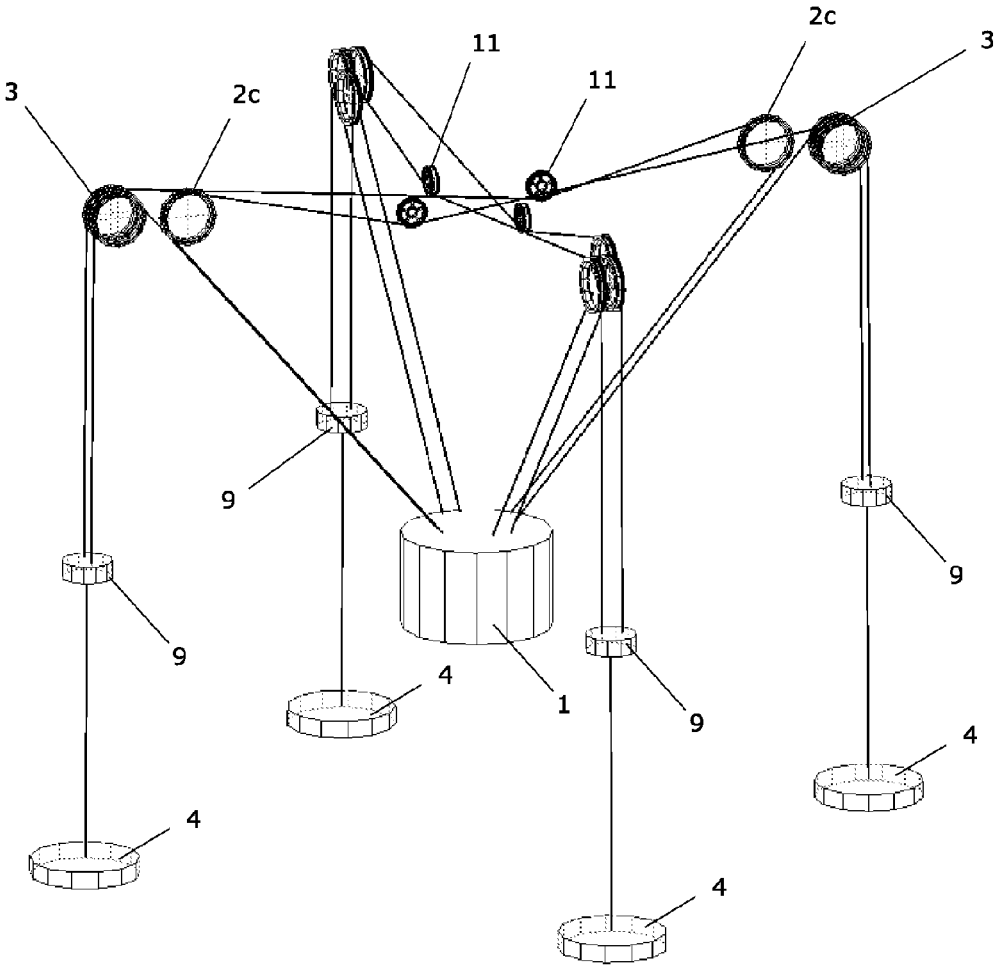

FIG. 8

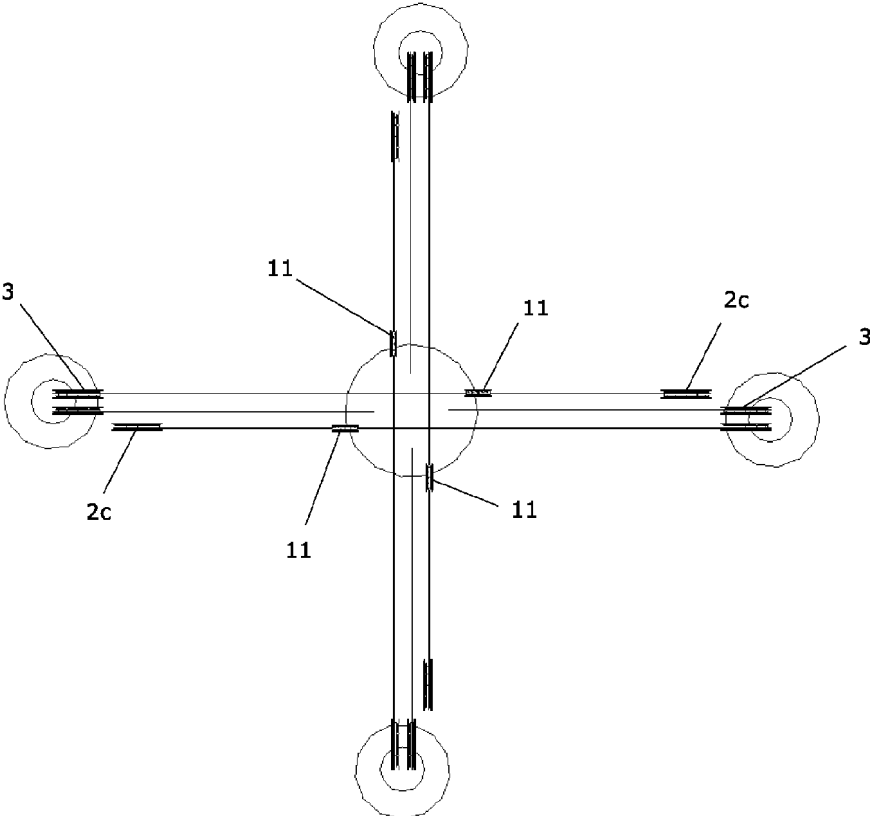

FIG. 9

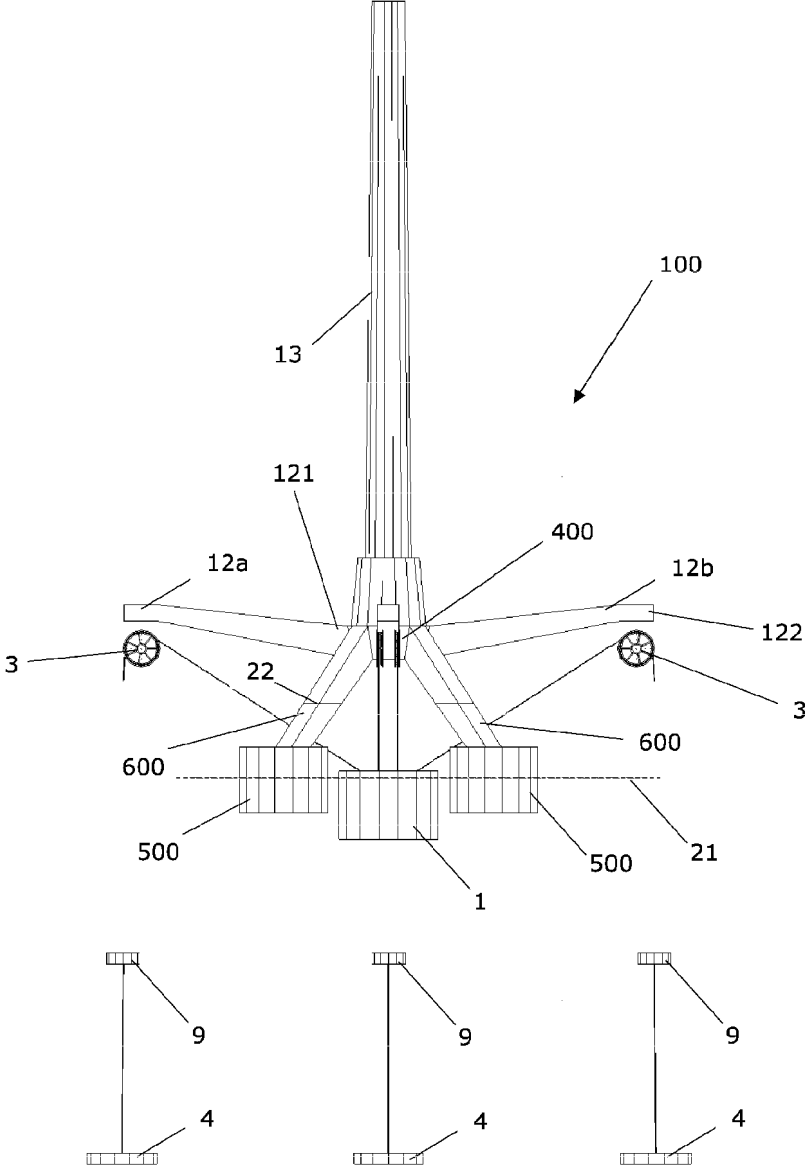

FIG. 10

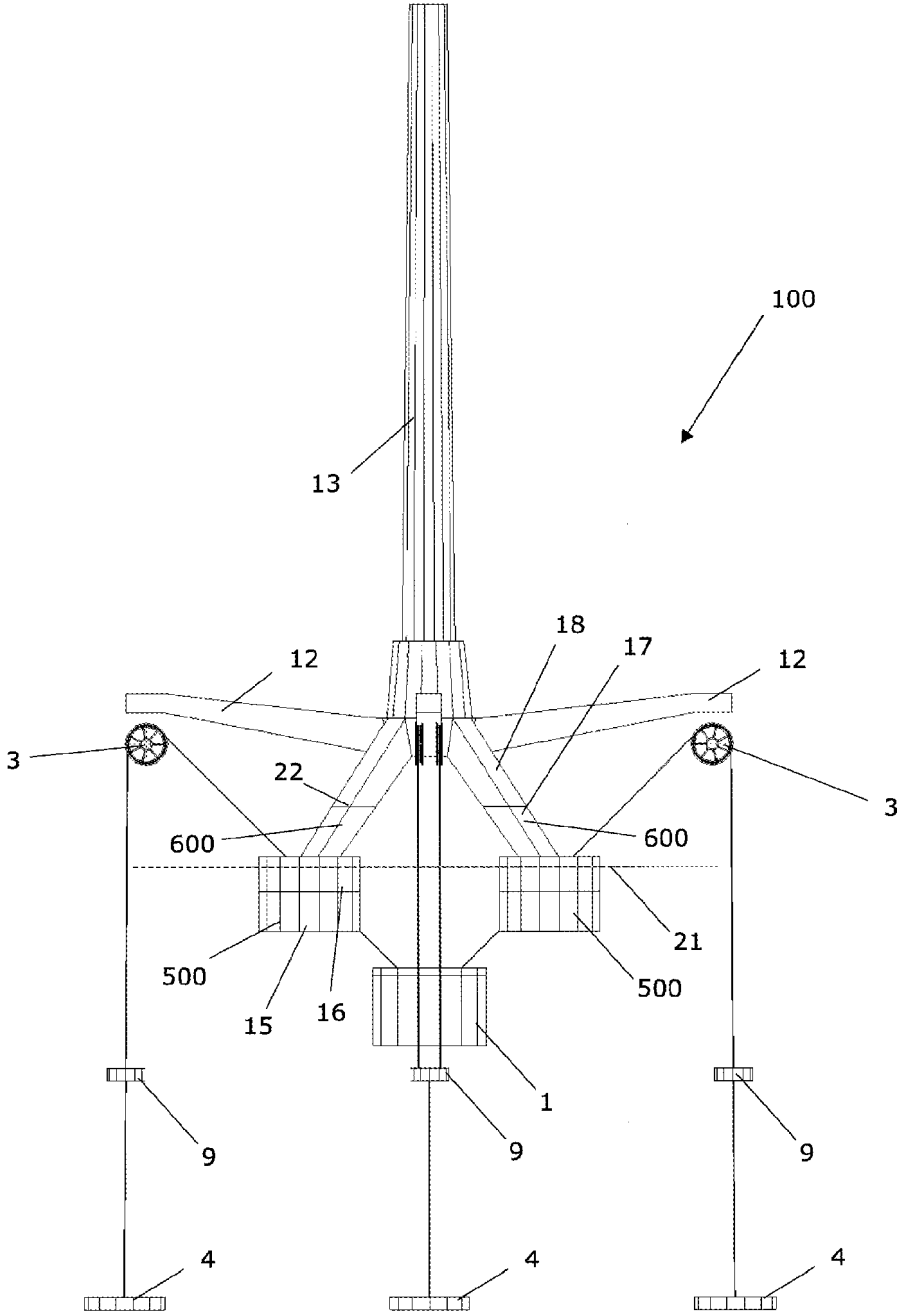

FIG. 11

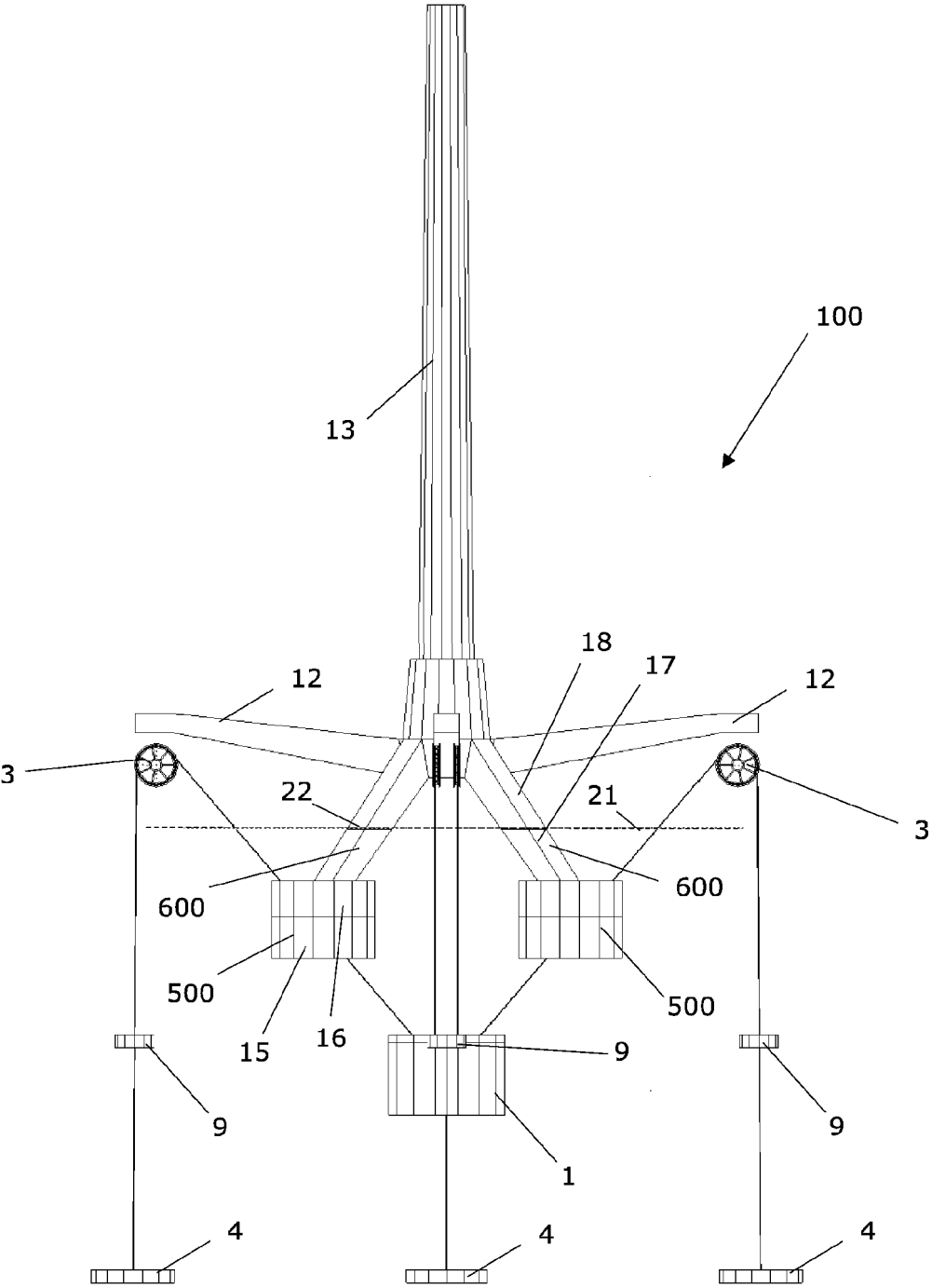

FIG. 12

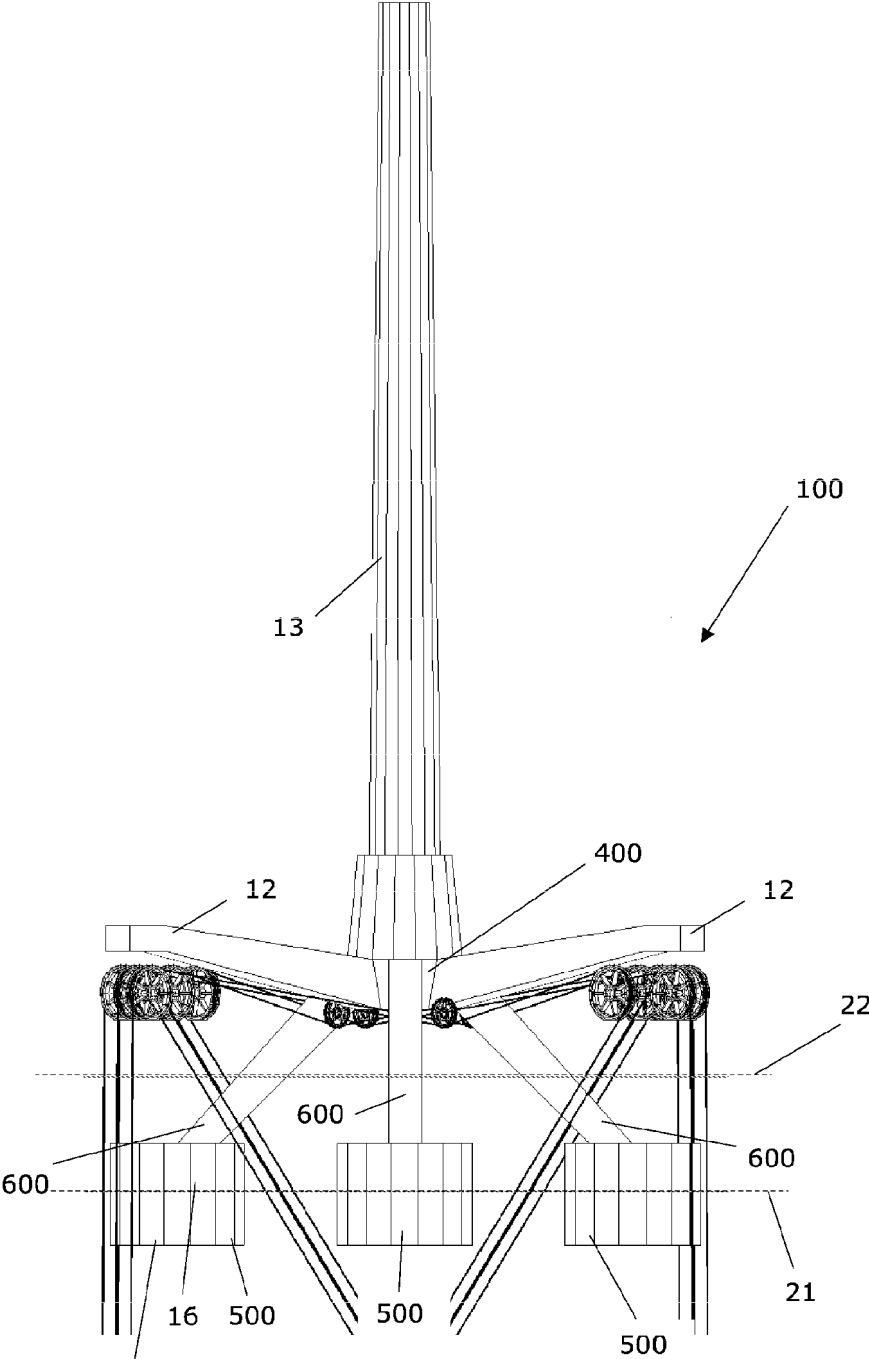
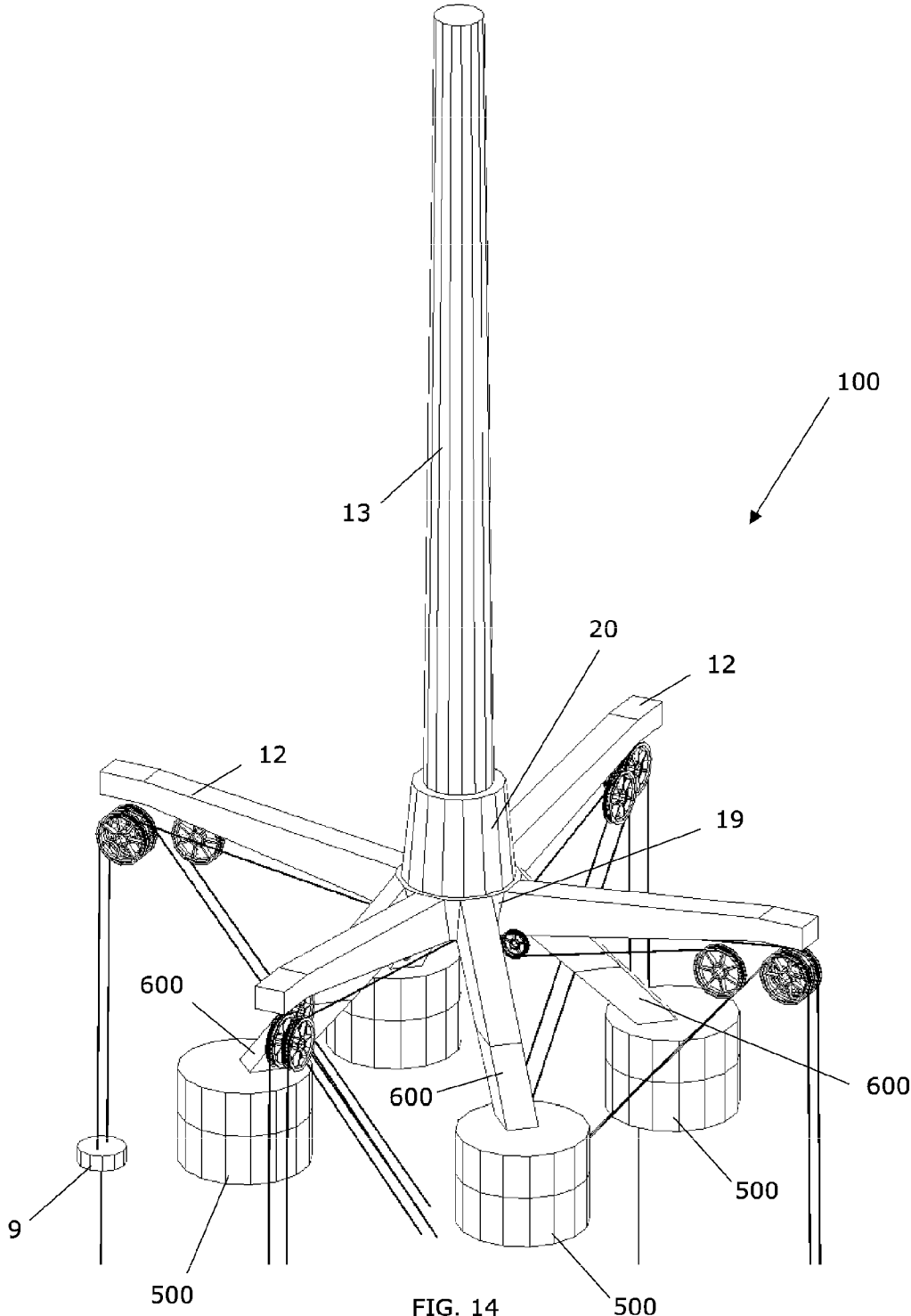

FIG. 13



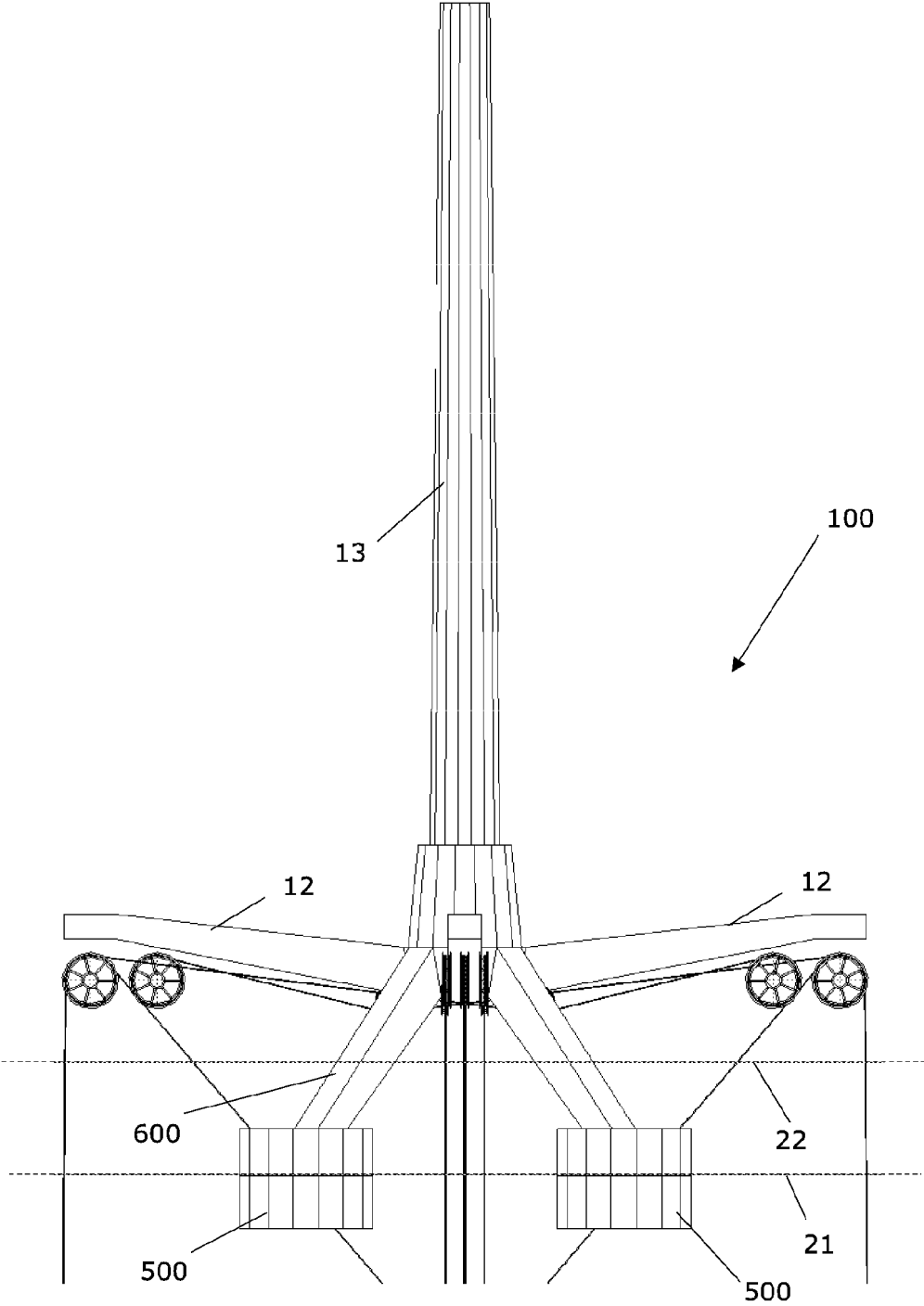

FIG. 15

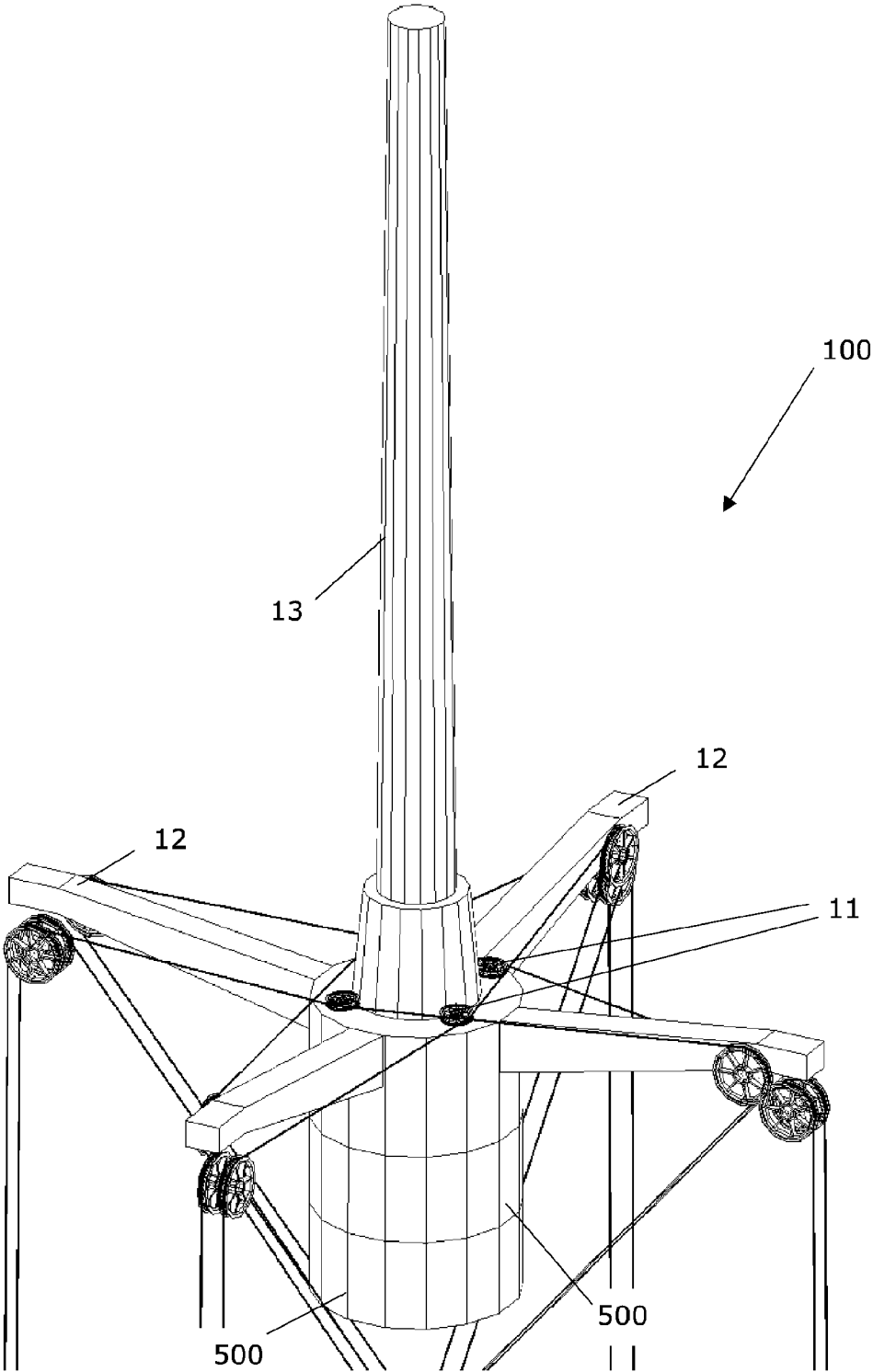

FIG. 17

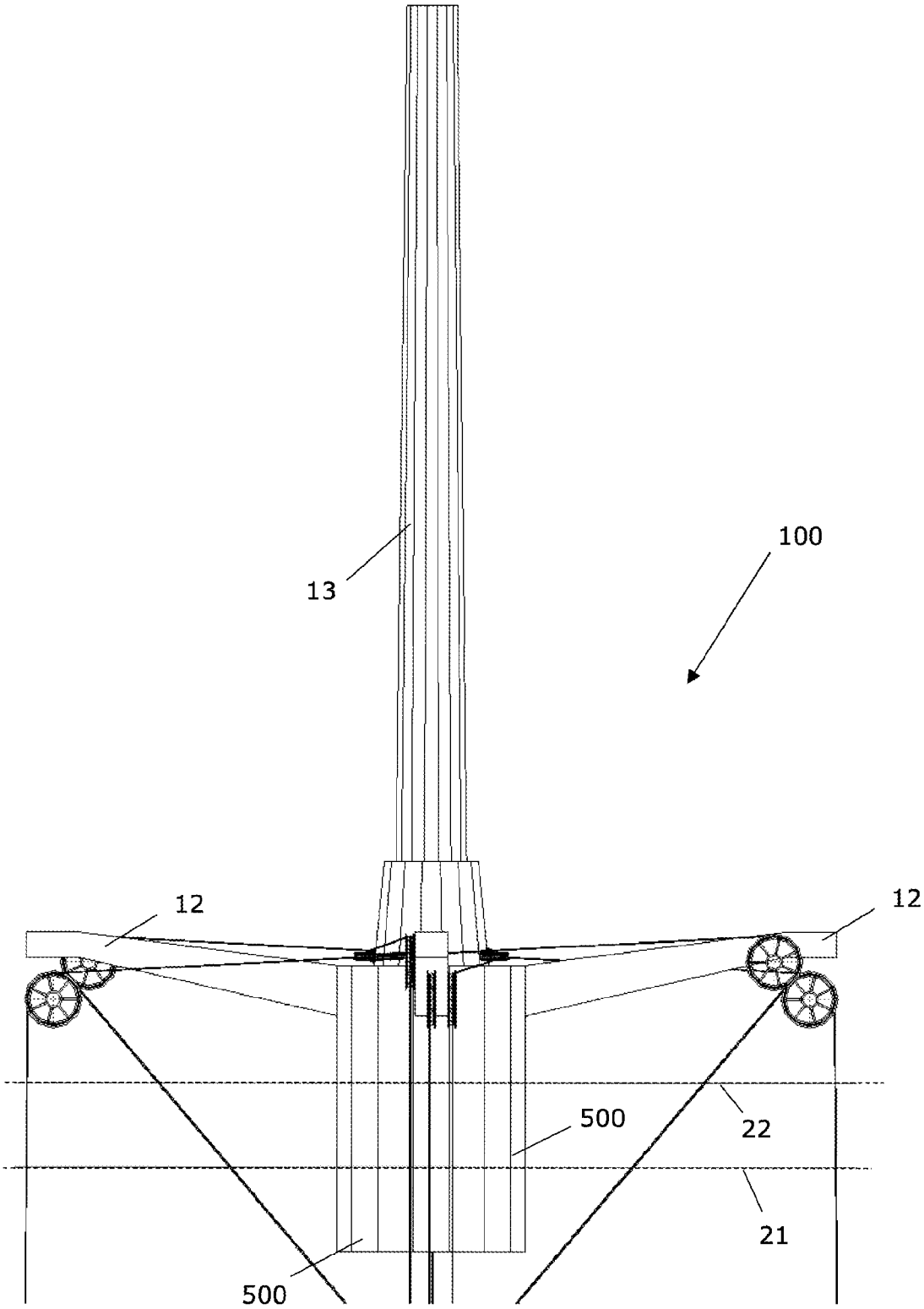

FIG. 18

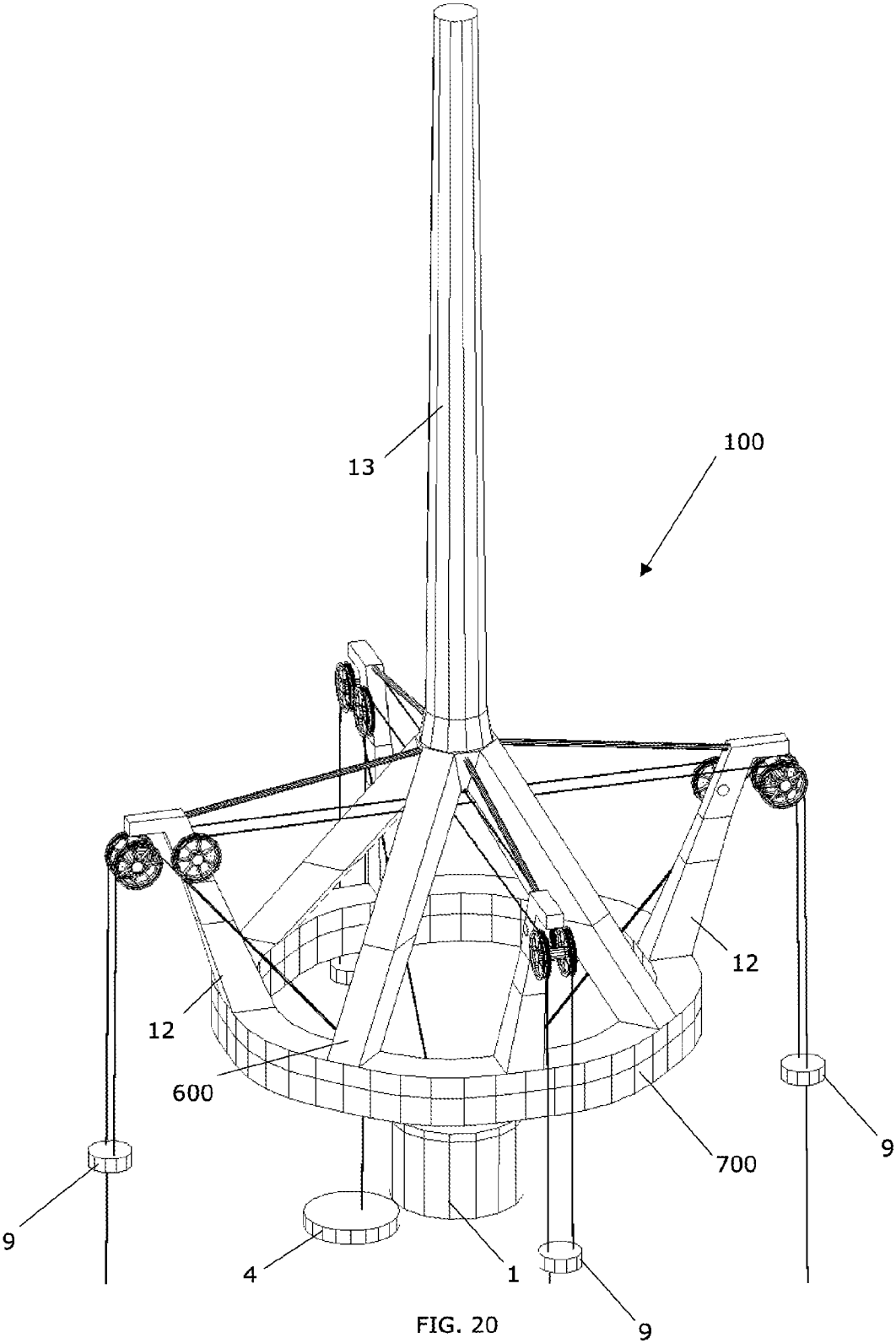

FIG. 20

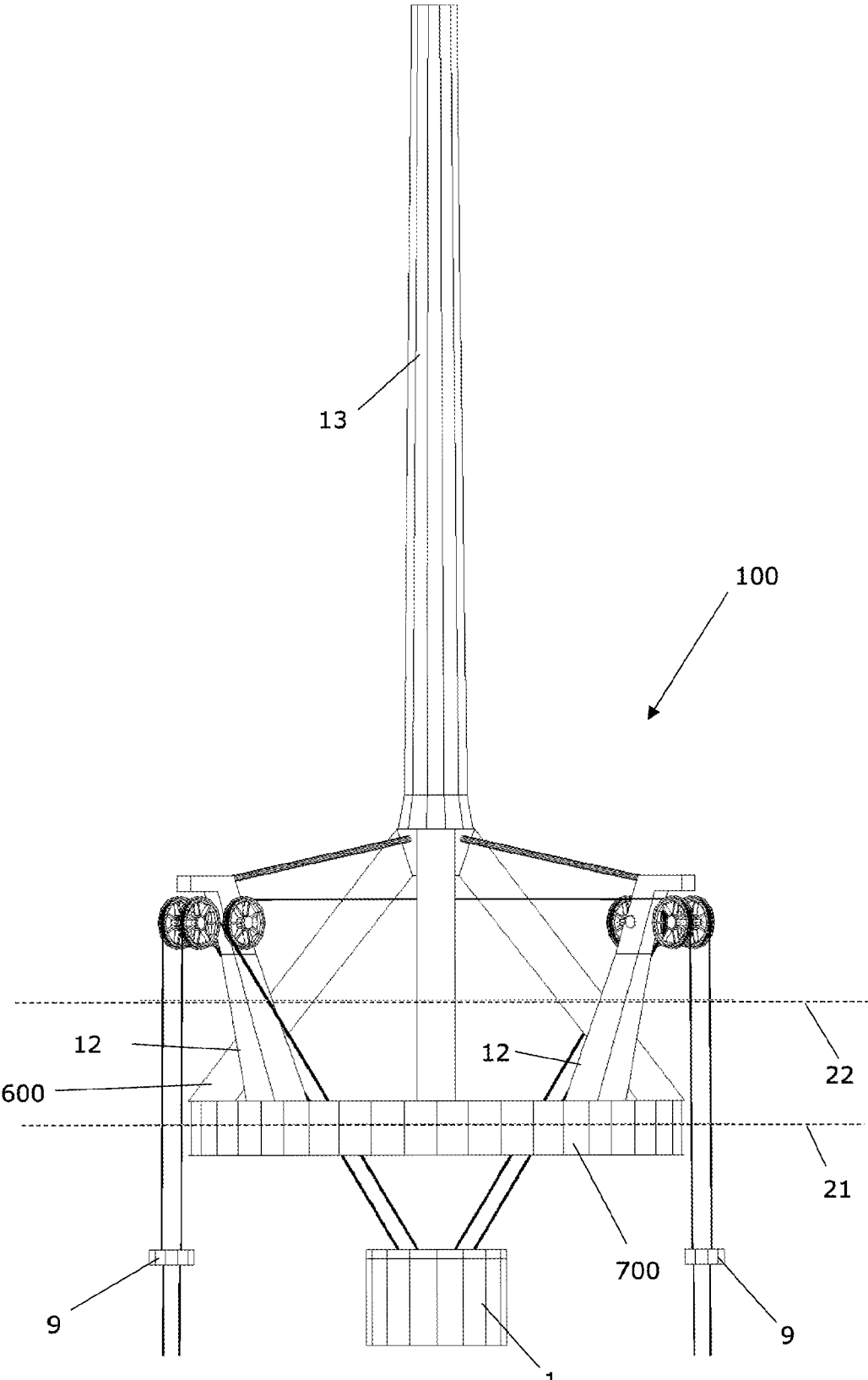

FIG. 21

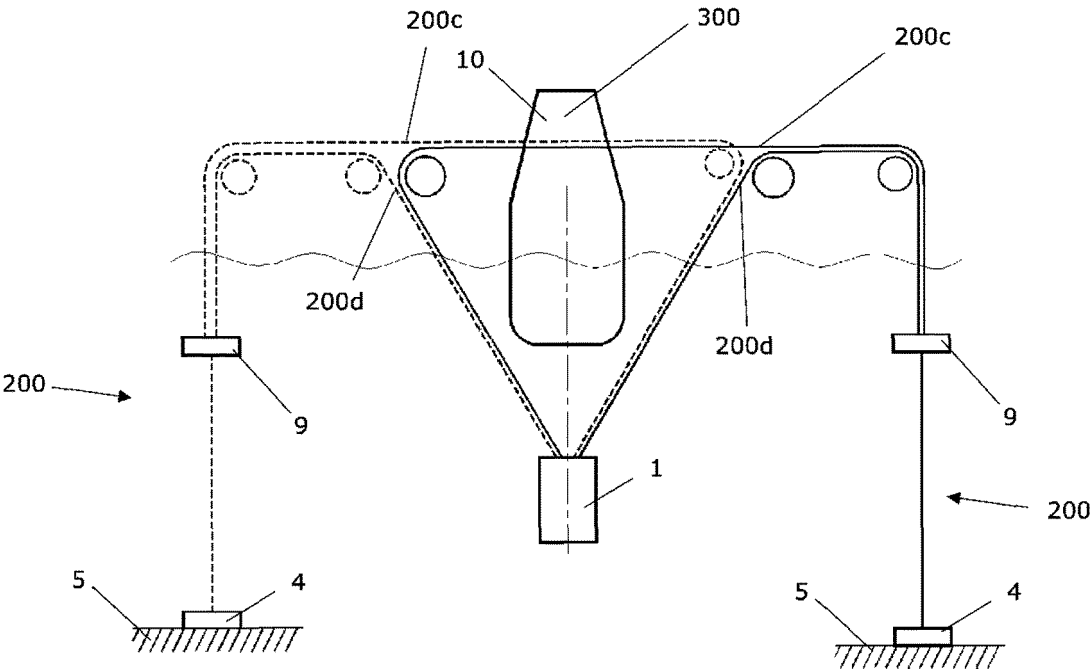

FIG. 1

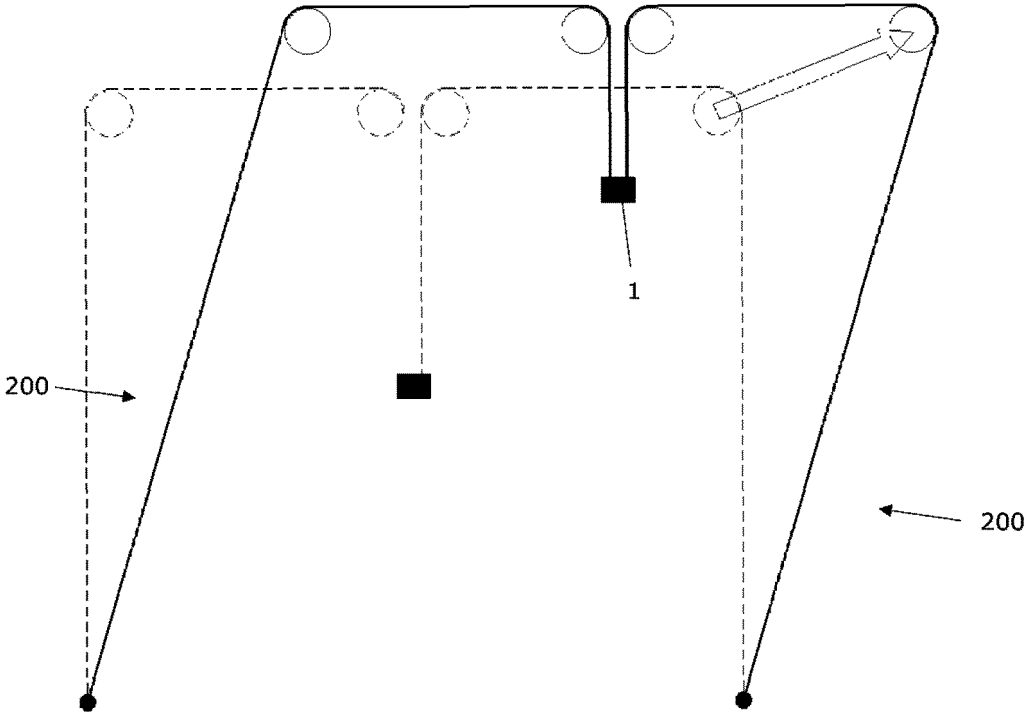

FIG. 2

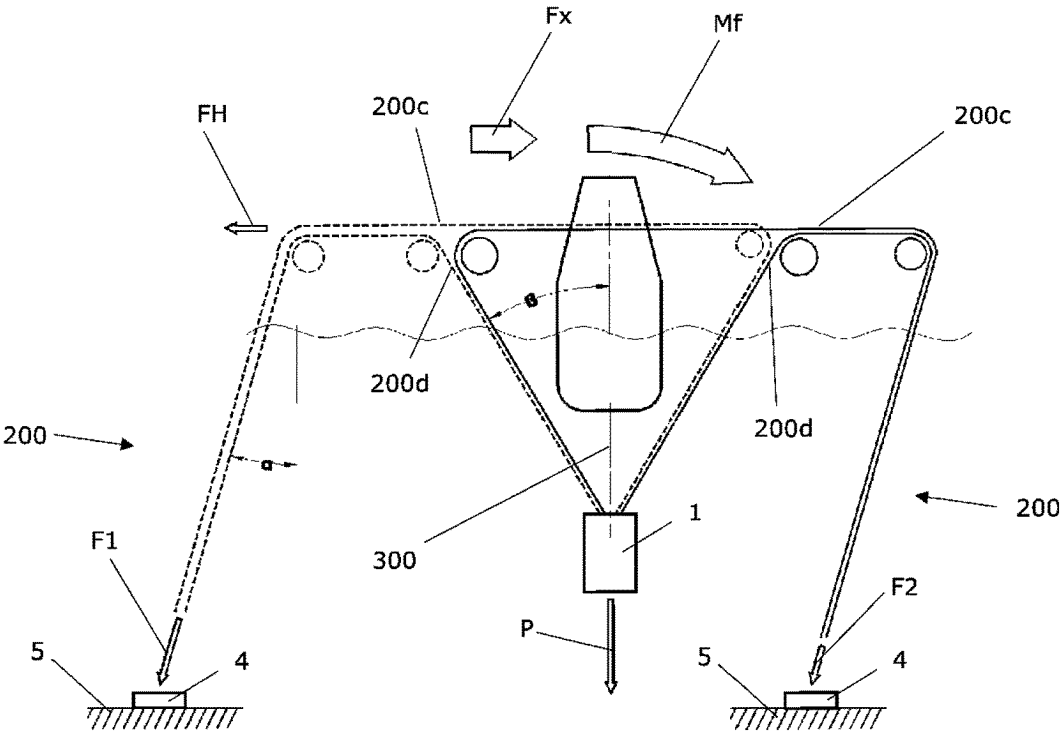

FIG. 3

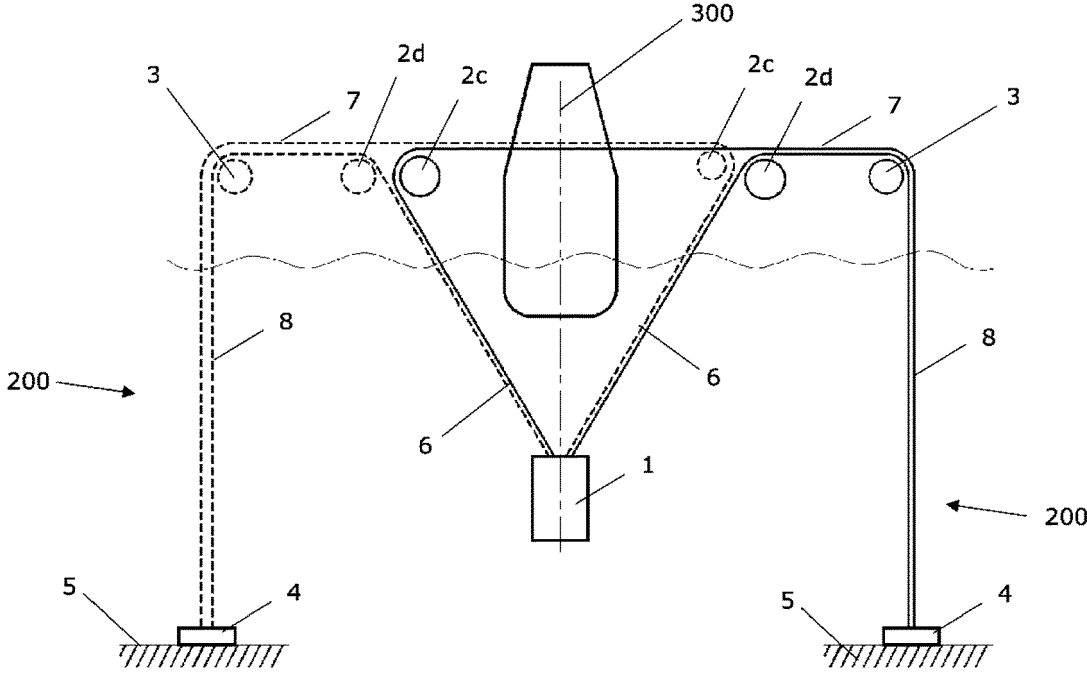

FIG. 4

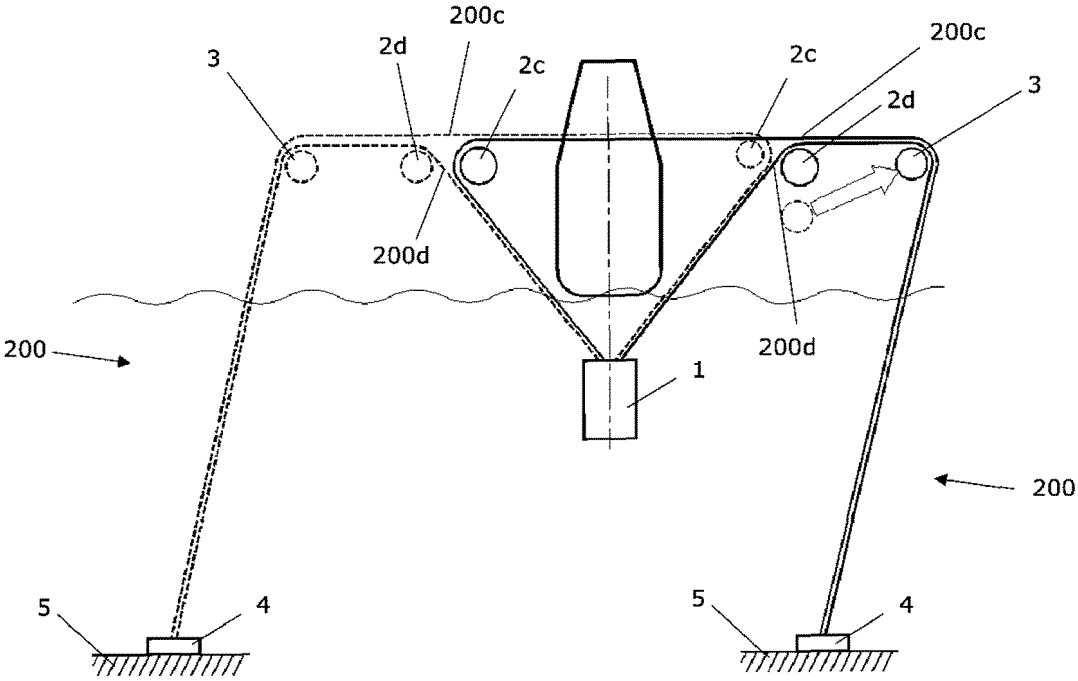

FIG. 5

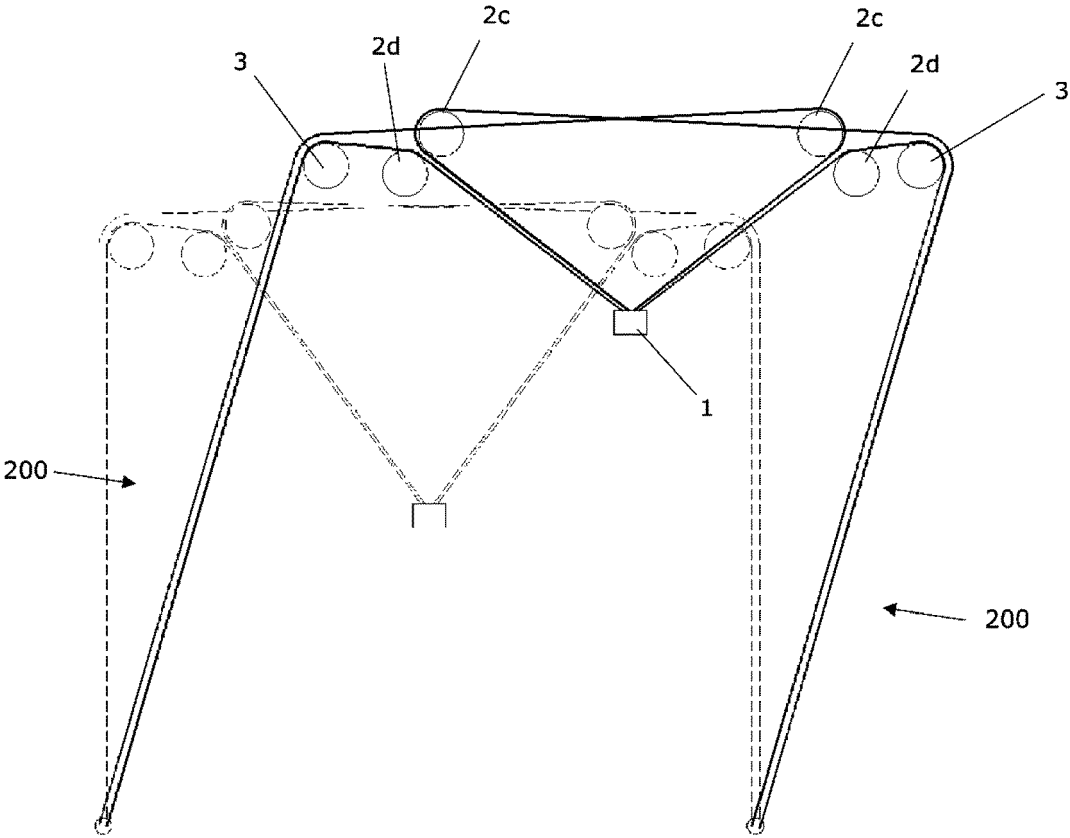

FIG. 6

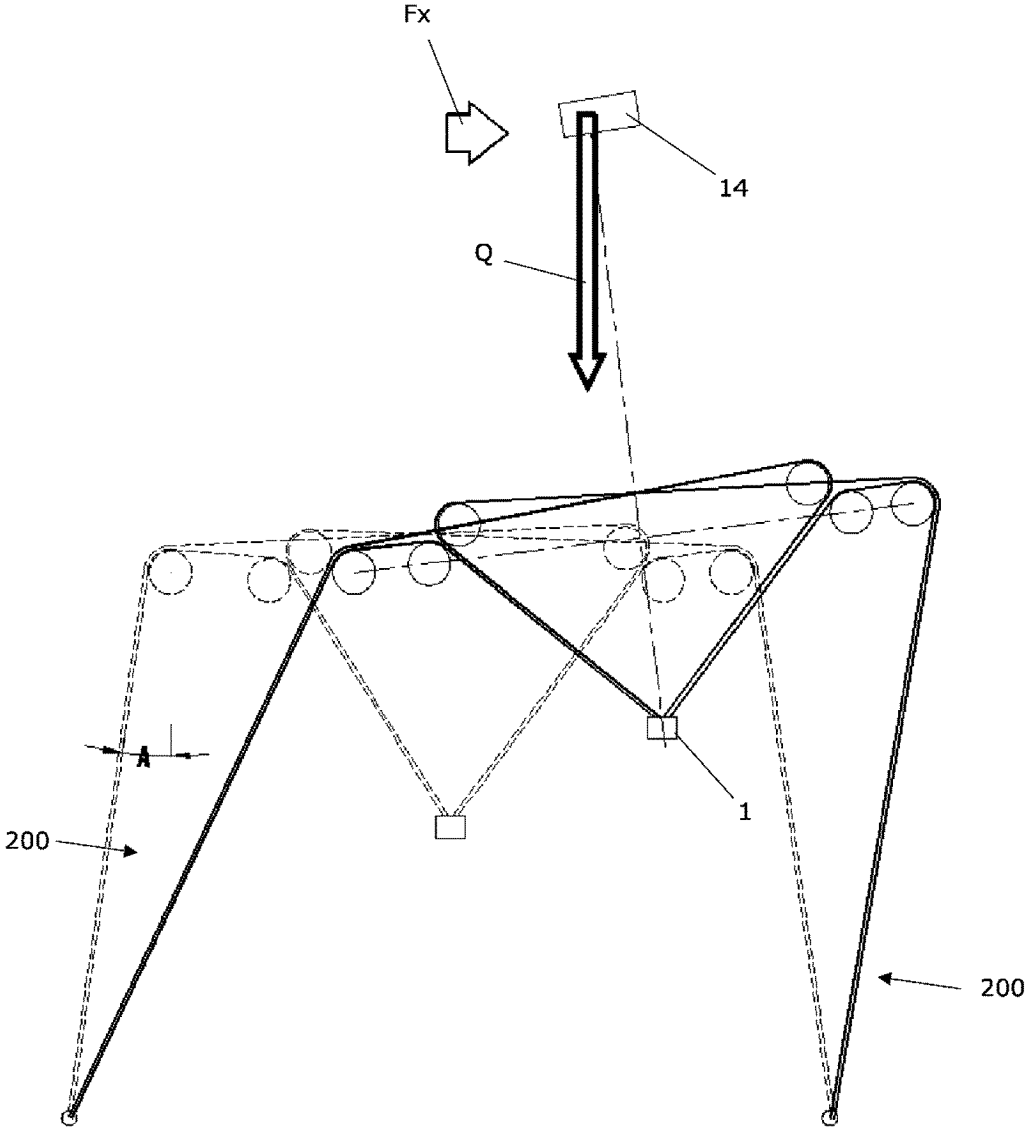

FIG. 7

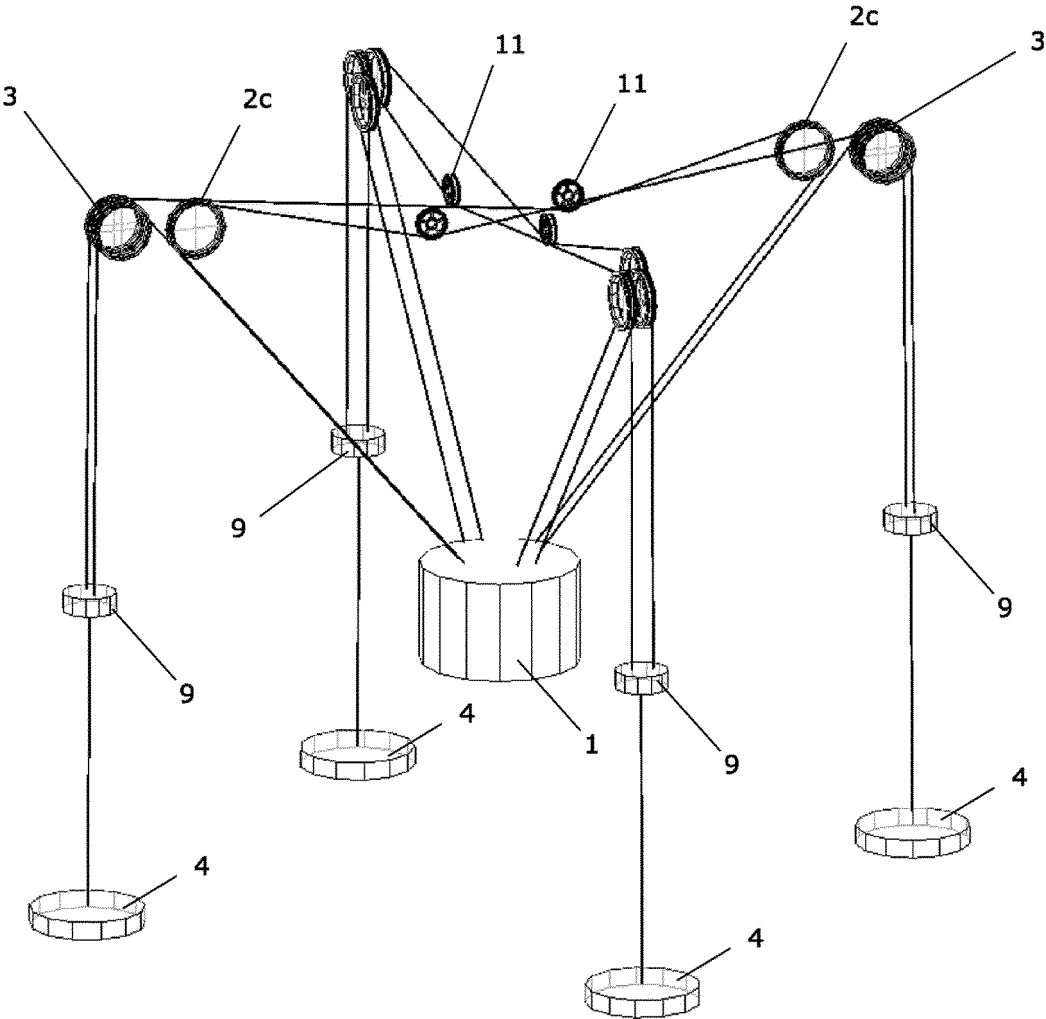

FIG. 8

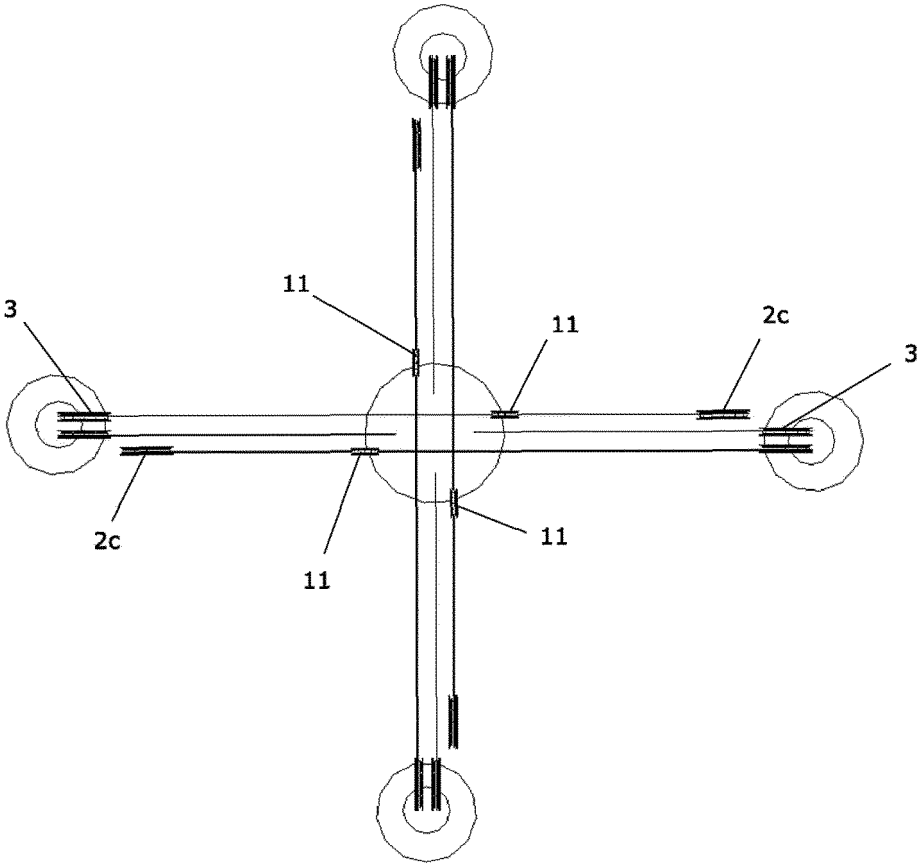

FIG. 9

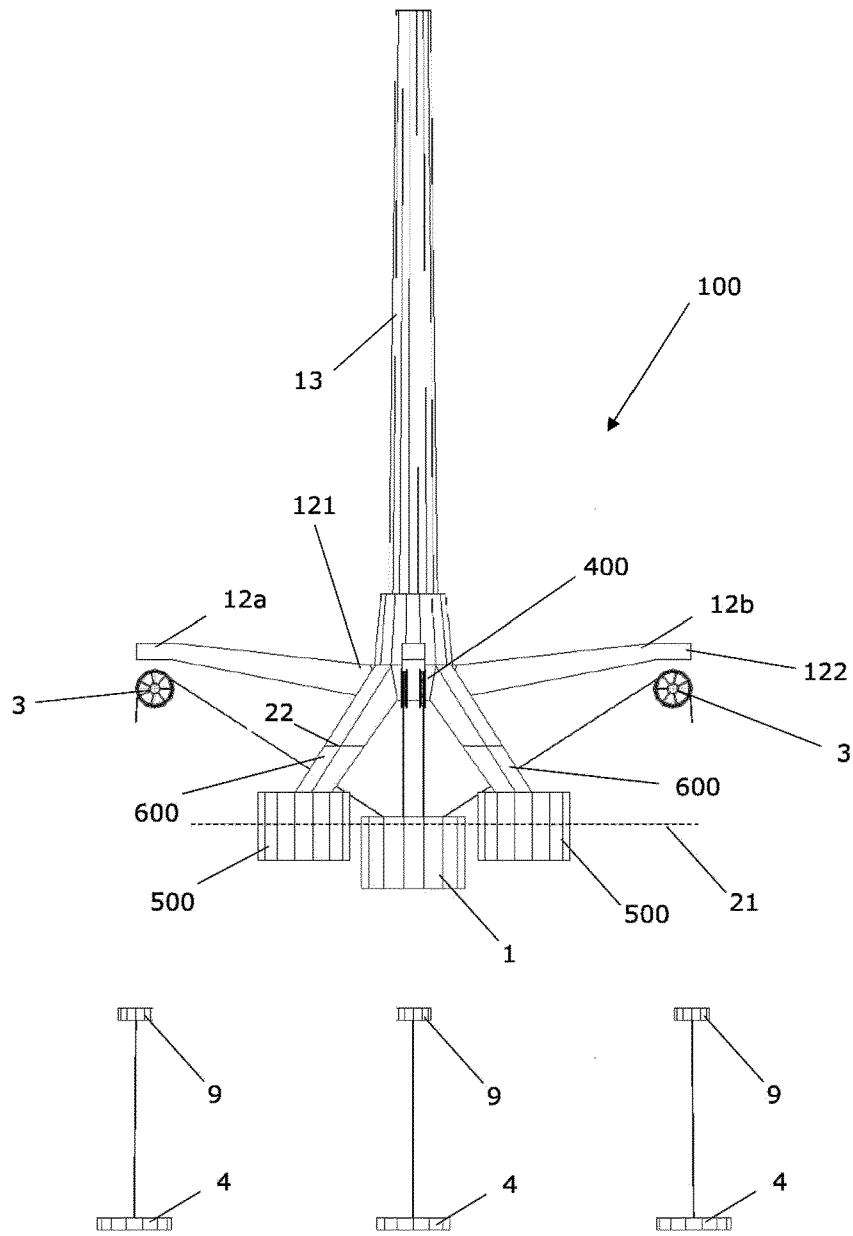

FIG. 10

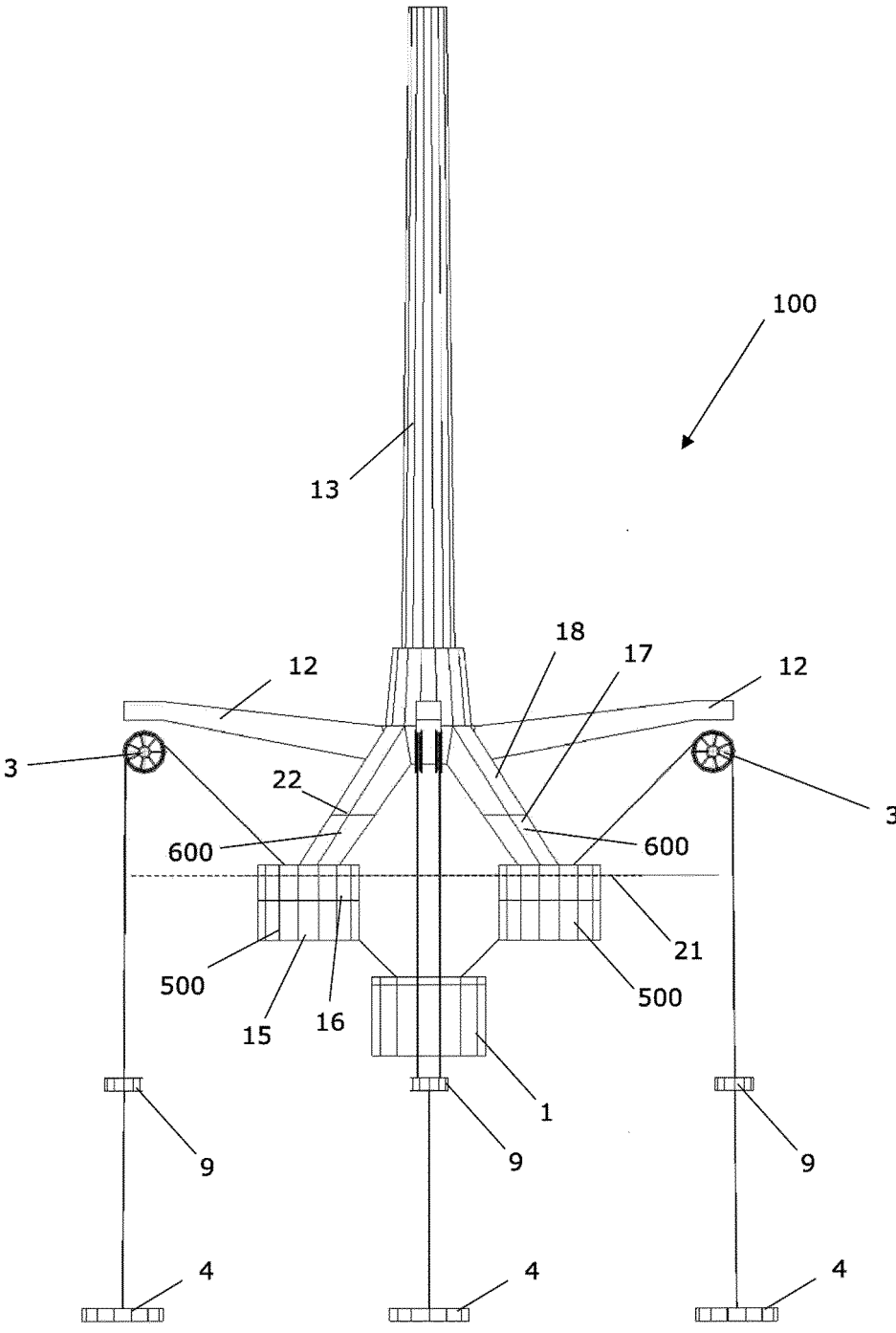

FIG. 11

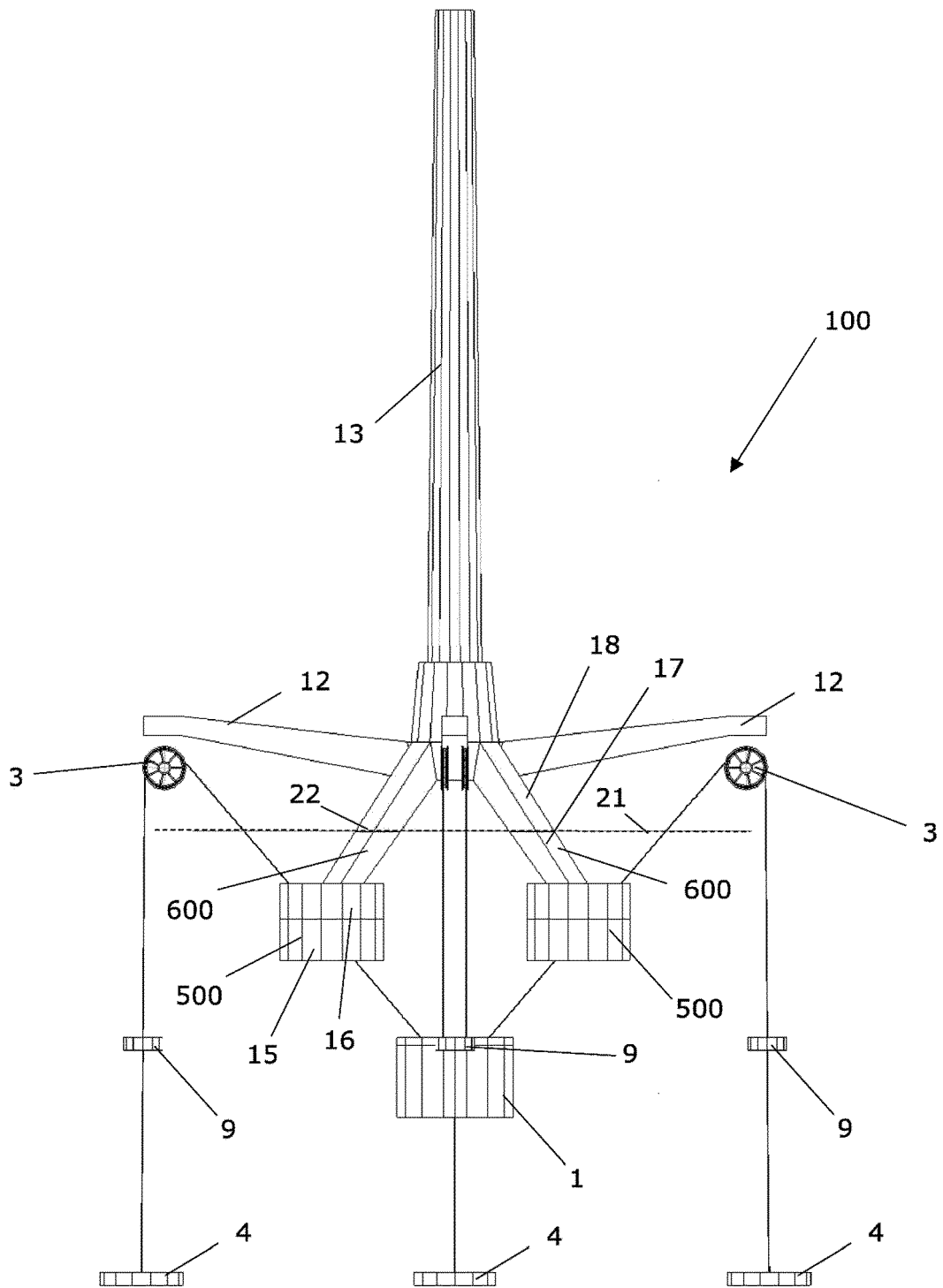
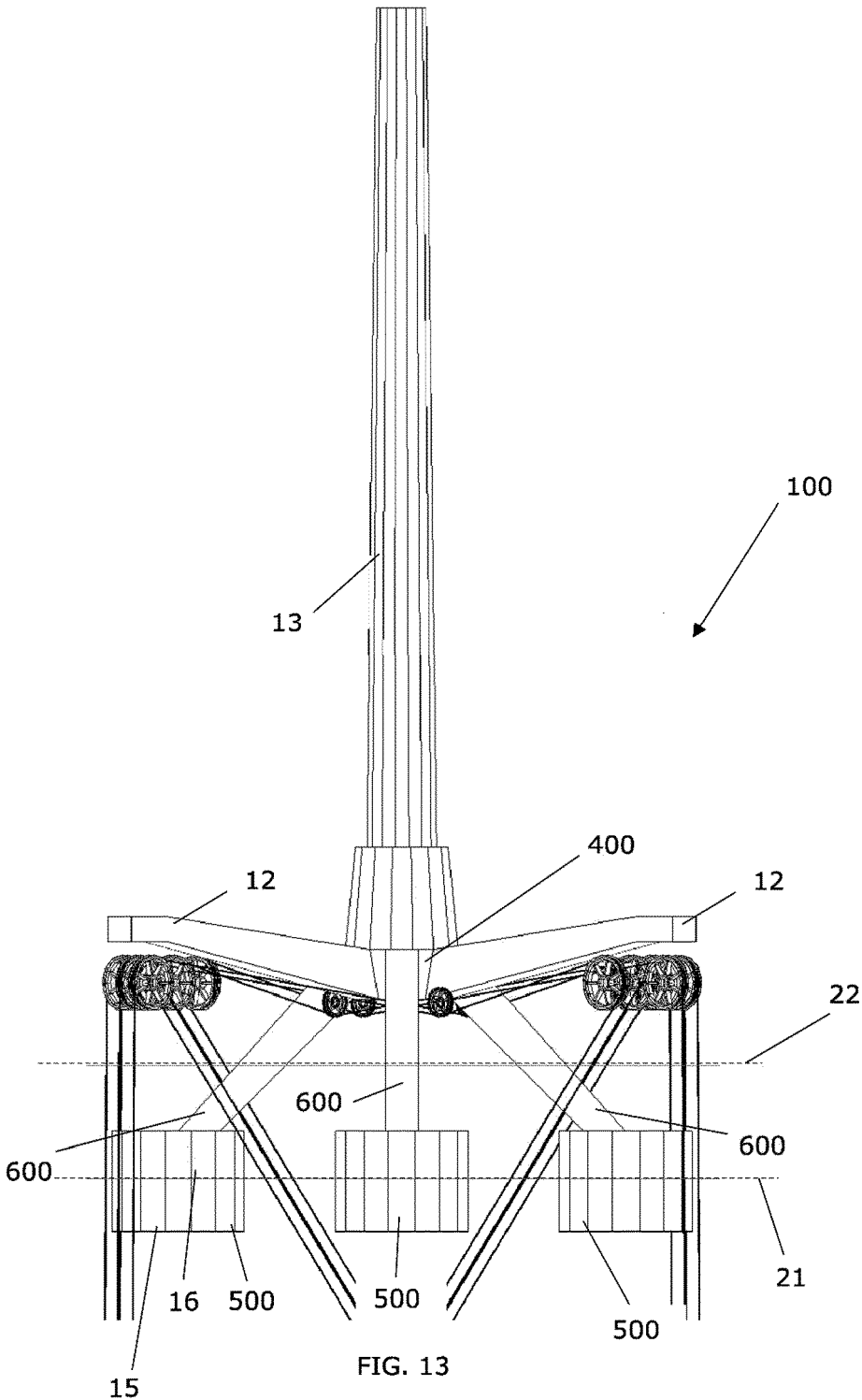

FIG. 12



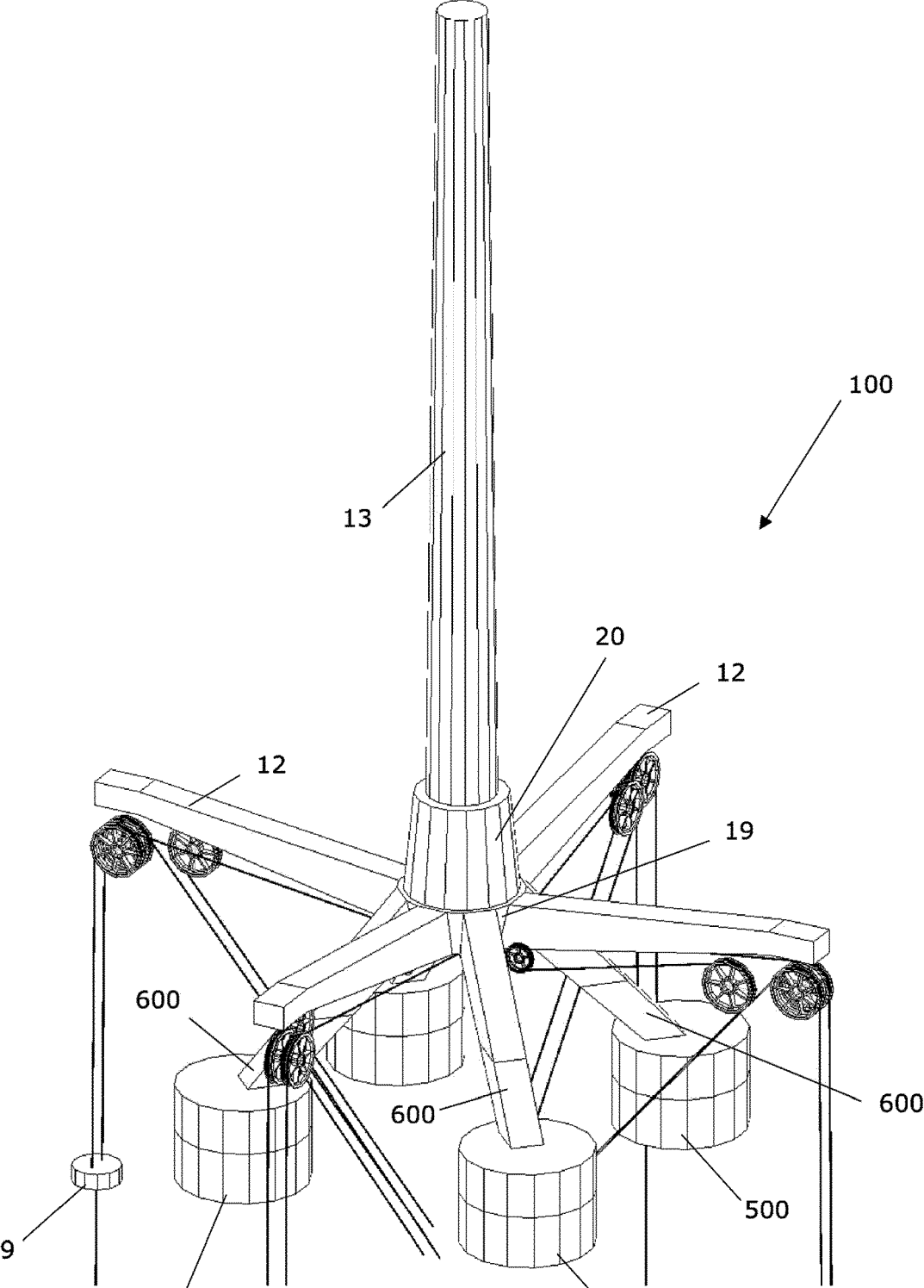

FIG. 14

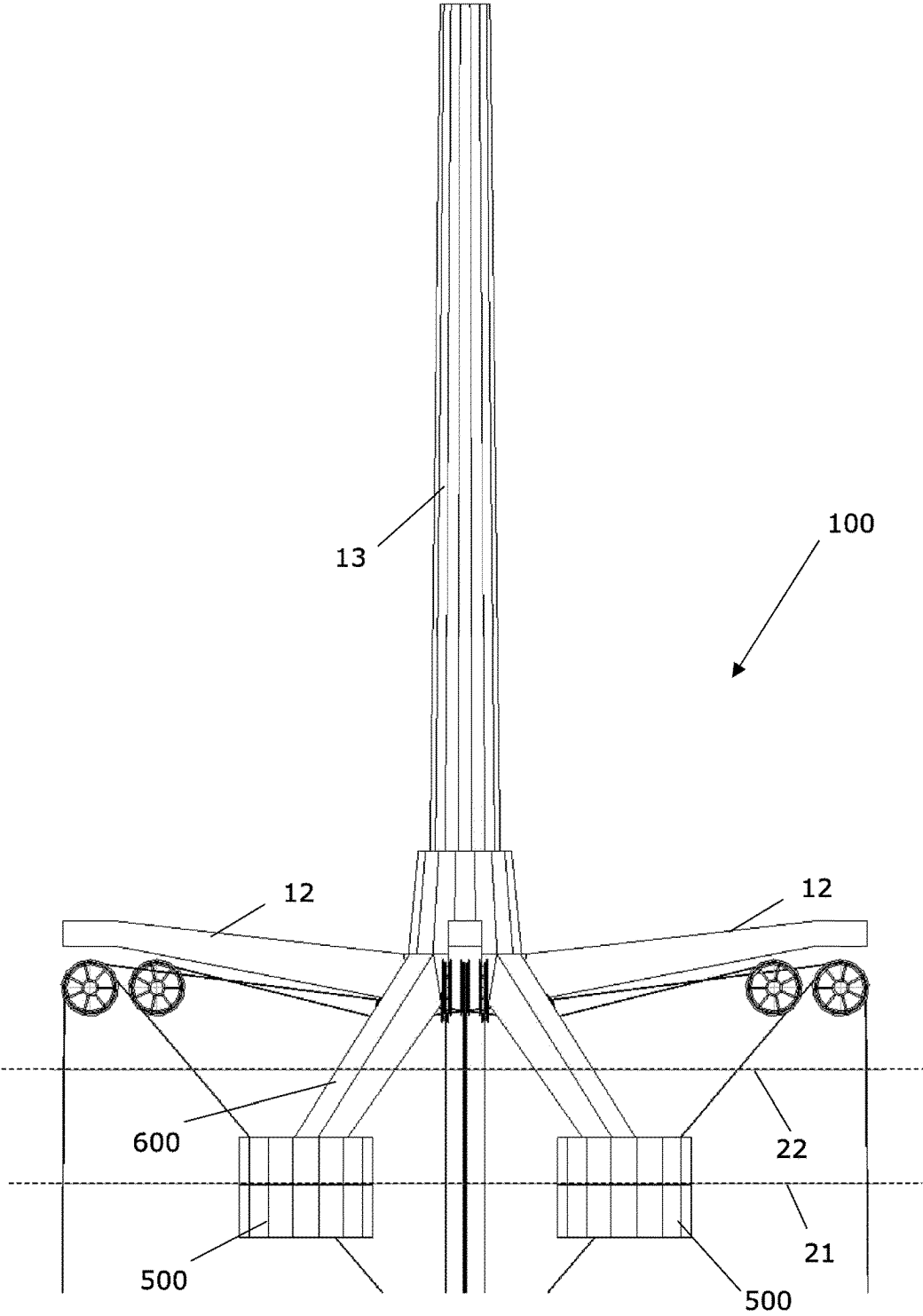

FIG. 15

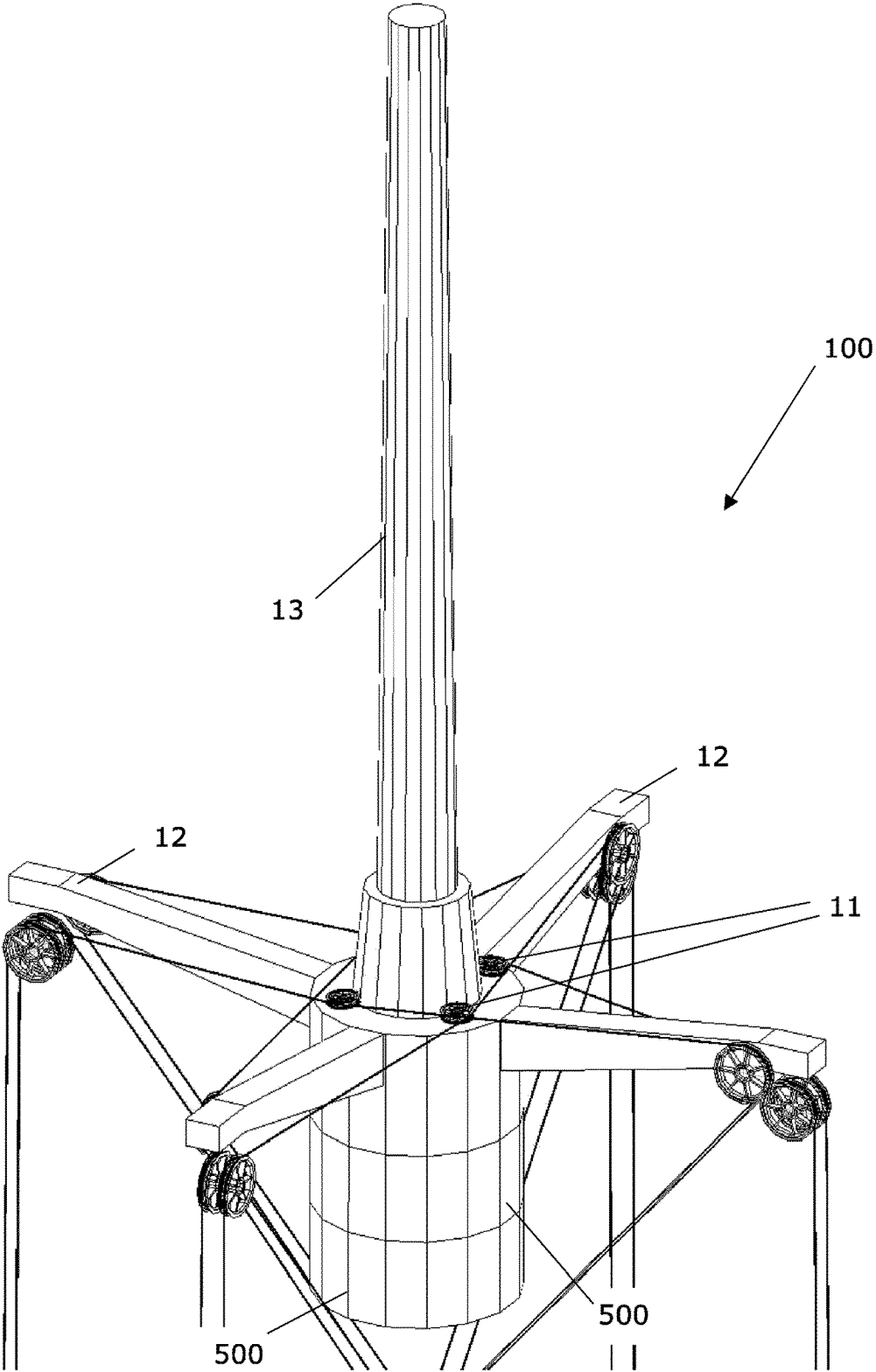

FIG. 17

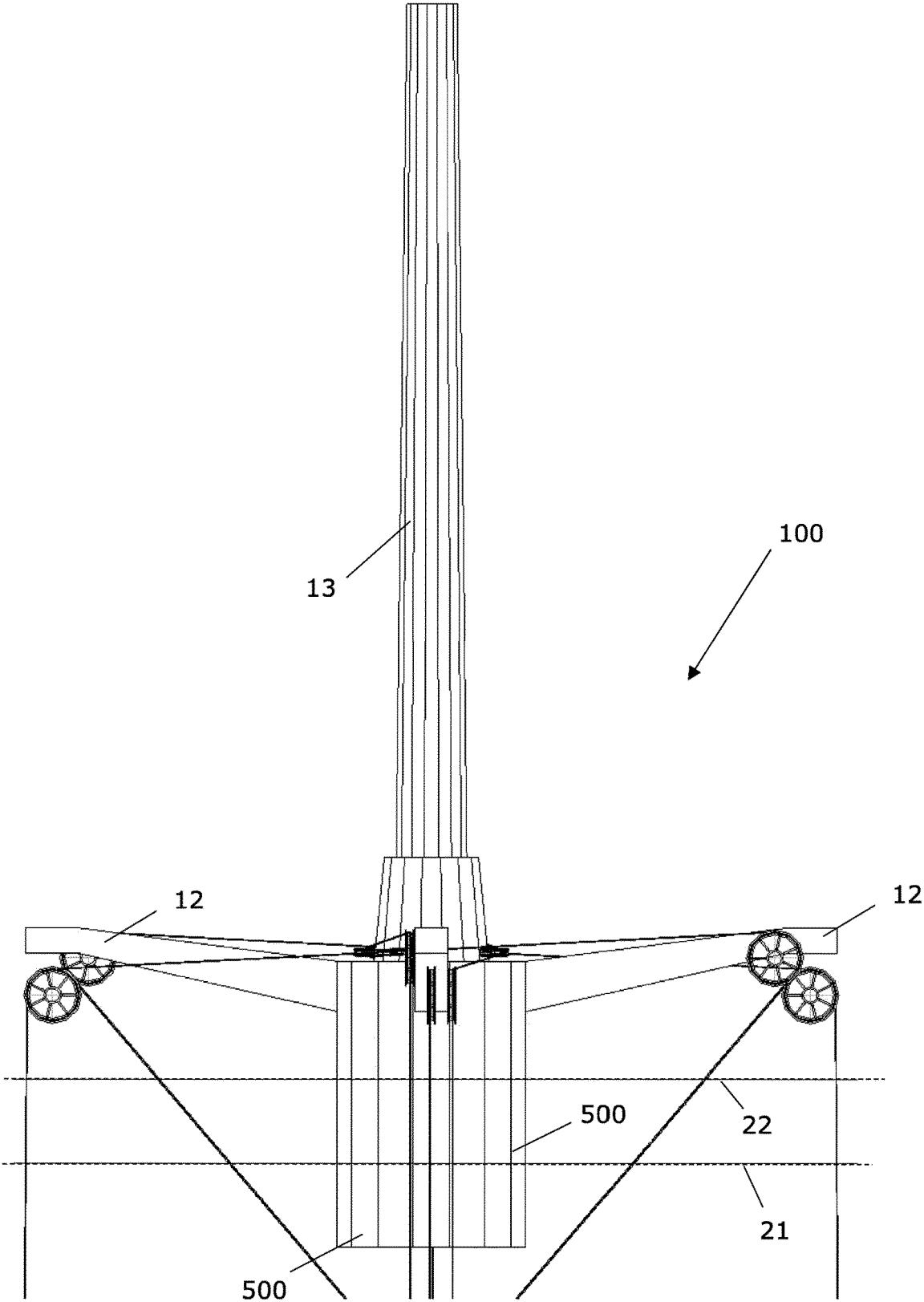

FIG. 18

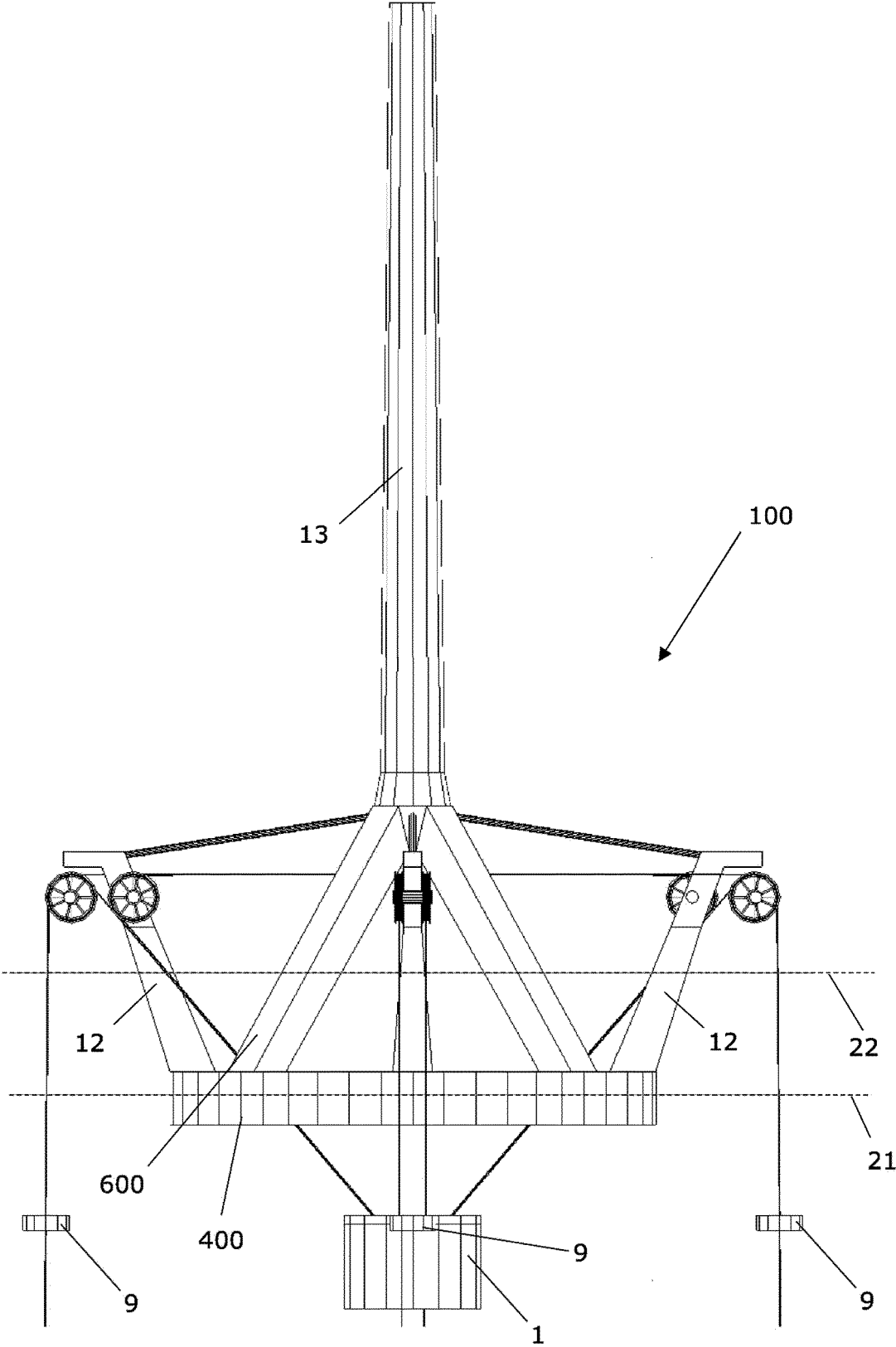

FIG. 19

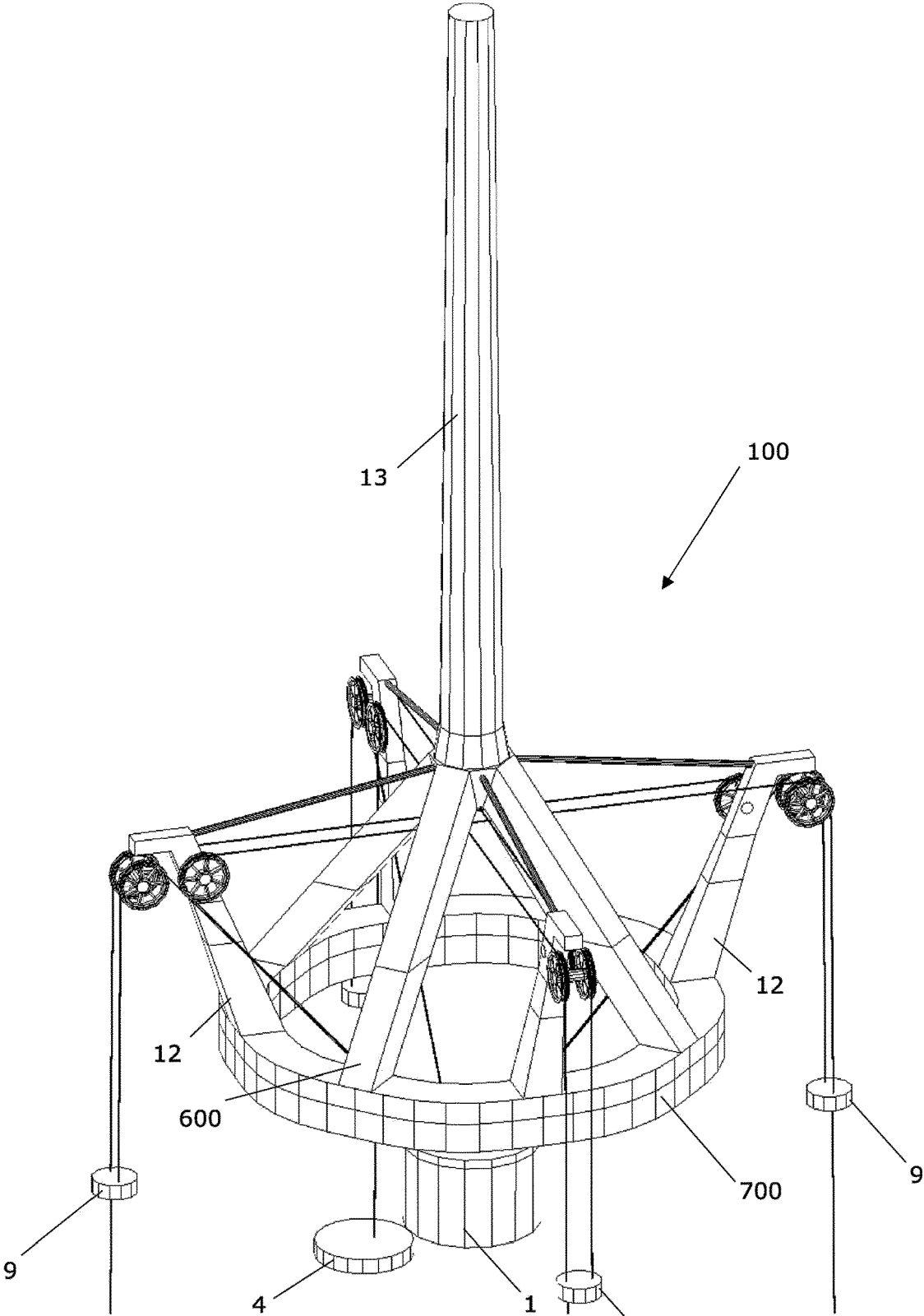

FIG. 20

REFERENCES CITED IN THE DESCRIPTION

This list of references cited by the applicant is for the reader's convenience only. It does not form part of the European patent document. Even though great care has been taken in compiling the references, errors or omissions cannot be excluded and the EPO disclaims all liability in this regard.

Patent documents cited in the description

- EP 2743170 A1 [0007]
- ES 2629867 A2 [0010] [0019] [0041] [0100]