

(19) World Intellectual Property Organization  
International Bureau



(43) International Publication Date  
18 September 2003 (18.09.2003)

PCT

(10) International Publication Number  
WO 03/076298 A1

- (51) International Patent Classification<sup>7</sup>: B65D 75/58, 83/08
- (74) Agents: O'CONNOR, Donal, H. et al.; Cruickshank & Co., 1 Holles Street, Dublin 2 (IE).
- (21) International Application Number: PCT/IE03/00039
- (22) International Filing Date: 10 March 2003 (10.03.2003)
- (25) Filing Language: English
- (26) Publication Language: English
- (30) Priority Data:
  - S2002/0183 8 March 2002 (08.03.2002) IE
  - S2002/0725 6 September 2002 (06.09.2002) IE
- (71) Applicant (for all designated States except US): EDMAK LIMITED [IE/IE]; Carney's Lane, Killineer, Drogheda, County Louth (IE).
- (72) Inventors; and
- (75) Inventors/Applicants (for US only): MCCLOSKEY, Edward [IE/IE]; Carney's Lane, Killineer, Drogheda, County Louth (IE). HOOD, Oliver [GB/IE]; Ballymoran House, Edenderry, County Offaly (IE).
- (81) Designated States (national): AE, AG, AL, AM, AT, AU, AZ, BA, BB, BG, BR, BY, BZ, CA, CH, CN, CO, CR, CU, CZ, DE, DK, DM, DZ, EC, EE, ES, FI, GB, GD, GE, GH, GM, HR, HU, ID, IL, IN, IS, JP, KE, KG, KP, KR, KZ, LC, LK, LR, LS, LT, LU, LV, MA, MD, MG, MK, MN, MW, MX, MZ, NO, NZ, OM, PH, PL, PT, RO, RU, SC, SD, SE, SG, SK, SL, TJ, TM, TN, TR, TT, TZ, UA, UG, US, UZ, VC, VN, YU, ZA, ZM, ZW.
- (84) Designated States (regional): ARIPO patent (GH, GM, KE, LS, MW, MZ, SD, SL, SZ, TZ, UG, ZM, ZW), Eurasian patent (AM, AZ, BY, KG, KZ, MD, RU, TJ, TM), European patent (AT, BE, BG, CH, CY, CZ, DE, DK, EE, ES, FI, FR, GB, GR, HU, IE, IT, LU, MC, NL, PT, RO, SE, SI, SK, TR), OAPI patent (BF, BJ, CF, CG, CI, CM, GA, GN, GQ, GW, ML, MR, NE, SN, TD, TG).

Published:  
— with international search report

[Continued on next page]

(54) Title: WET TISSUES DISPENSER

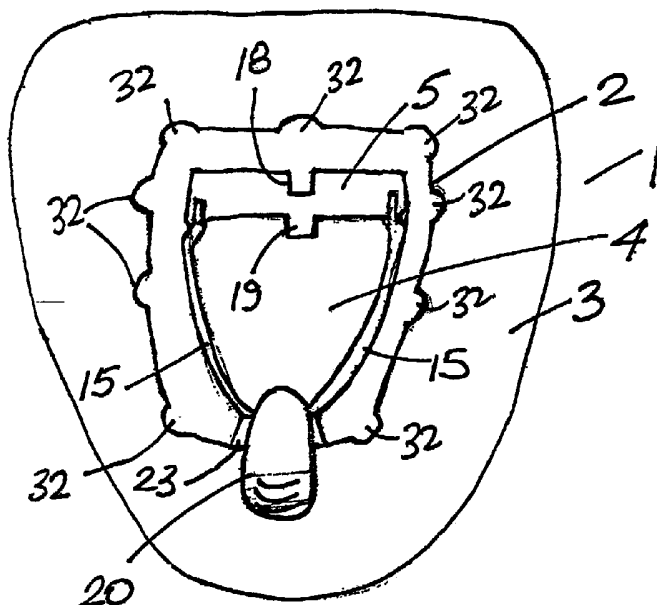

(57) Abstract: A dispenser (1) for a pack of wet wipes, has a stiff plastics material body (2) with a peripheral mounting flange (3) for attachment to a sidewall of a pack of wipes. A tear-open closure (4) is integrally formed with the body (2). A portion of a periphery of the closure (4) is tearable away from the body (2) to leave the closure (4) attached to the body (2) by a hinge (5). The closure (4) is mounted at an opening in the body (2) across which is stretched a silicone membrane having a circular dispensing opening through which wipes are dispensed from a flow-wrap plastics pack of wipes on which the dispenser (1) is mounted.



WO 03/076298 A1



---

*For two-letter codes and other abbreviations, refer to the "Guidance Notes on Codes and Abbreviations" appearing at the beginning of each regular issue of the PCT Gazette.*

- 1 -

## WET TISSUES DISPENSER

This invention relates to a wipes dispenser, and in particular to a portable wipes dispenser for wet wipes.

5

In the prior art it is known to provide wet wipes in the form of a roll which is housed within a dispenser comprising a cylindrical container of rigid plastics material. Wipes are fed from a centre of the roll out through a central dispensing opening in a top of the container and torn away from the roll along perforated lines for use. A lid is usually  
10 provided to cover the top of the container when not dispensing wipes to limit moisture loss. A problem with this type of dispenser is that it generally can not handle thicker fabrics (e.g. 30-60gsm) satisfactorily, such fabrics now being common in baby care and skin care products. Further, the container is a relatively expensive type of packaging which is typically discarded after use. Also, it may not be sufficiently airtight  
15 or the cover may be removed or simply left open leading to moisture loss from the wipes. Finally, the container is relatively bulky and is therefore not conveniently portable for example in a handbag or the like.

In another known type of dispenser there is provided a reusable plastics tub containing  
20 a stack of wipes which may or may not be flow wrapped. Replacement packs of wipes are available for recharging the tub. Unfortunately this dispenser is relatively bulky and cumbersome even when empty. It is also awkward and tedious to prime a dispensing opening of the dispenser with a leading end of the topmost wipe. From a manufacturing point of view the dispenser is relatively expensive to produce with too  
25 many components.

It is also known to provide a stack of wet wipes in a flow wrapped plastics package. A dispensing opening is provided at a top of the package through which wipes are pulled from the top of the stack. This dispensing opening is covered when not in use by a  
30 peel and reseal sticker. Typically, the sticker fails after relatively few uses and this leads to a severe drying out problem with the wipes. To address this problem it is known to attach an injection moulded plastics lid assembly over the dispensing opening which can be opened for dispensing wipes and closed to retain moisture within the pack when the pack is not in use. However, the adhesive with which the lid

- 2 -

assembly is attached to the flow wrap pack may be attacked by the wipe damping fluids leading to failure. Also, the lid is not airtight so there is still moisture loss from the wipes in the pack. Further, generally speaking single-handed removal of wipes is not possible which is somewhat inconvenient. Also, with these types of flow-wrapped dispenser packs often the wipes fail to come out of the pack easily or they "daisy-chain" out in quantity with consequent wastage. From a manufacturing point of view the wipes must be wetted before being packed presenting handling difficulties. Another problem with these types of pack is that they are fairly easy to tamper with.

10 The present invention is directed towards overcoming these problems.

According to the invention there is provided a dispenser for a pack of wipes, including a body having a mounting flange for attachment to a side wall of the pack about an outlet opening in said side wall, a wipes dispensing opening in the body for co-  
15 operation with the outlet in the side wall of the pack to allow dispensing of wipes from the pack, and a tear-open closure which is integrally formed with the body and extends across the dispensing opening to close the dispensing opening, a portion of a periphery of the closure being tearable away from the body to leave the closure attached to the body by a hinge, an elastic membrane being mounted on the body  
20 inside the closure extending across the dispensing opening, the elastic membrane having a through hole for reception and through passage of a wipe for dispensing wipes from the pack.

An advantage of the present invention is that the pack is fully sealed prior to use  
25 preventing moisture loss and promoting a long shelf life. Also, to gain access to the wipes the closure must be torn away from the body of the dispenser and this would give indication of any tampering with the contents prior to use. Further the elastic membrane and closure combine to provide a very effective seal preventing moisture loss from the wipes during storage.

30 The body of the dispenser is of a stiff plastics material which holds its shape but will allow some bending or flexing of the body.

In a preferred embodiment the closure is defined by lines of weakness formed by

reduced material thickness in the body which extend partially around the closure terminating at a hinge edge of the closure, said lines of weakness frangibly connecting the closure to the body such that it can be peeled away from the body along the lines of weakness for hinging about the hinge at an inner edge of the closure.

5

Preferably the elastic membrane is formed of silicone, rubber or other resiliently deformable elastic material. The size of the dispensing opening, the resilient properties of the elastic membrane or opening surround and the interconnection of adjacent wipes are chosen such that the leading or outermost wipe can be drawn through the dispensing opening without prematurely parting the outermost wipe from the following adjacent wipe and the force applied by the resilient dispensing opening surround to said following adjacent wipe is sufficient to allow parting away from the outermost wipe. As the outermost wipe parts away, the following wipe will continue to be drawn through the opening so that when parting of the outermost wipe is completed the leading edge of the following adjacent wipe projects through the opening so that it can subsequently be gripped to pull the next wipe from the container. It will be appreciated that this construction of flexible dispensing opening is very good at minimising evaporation and moisture loss from wet wipes in the container.

10  
15  
20

It will be noted that the dispensing opening may be provided in any suitable format. For example, it may be provided by an elongate slit or by a circular hole in the elastic membrane.

25

In another embodiment clamp means is provided for attachment of the elastic membrane to the body of the dispenser.

30

In one embodiment the clamp means comprises a complementary pair of clamp jaws, namely a first jaw and a second jaw, which are interengagable to clamp the elastic membrane therebetween.

Preferably one of said jaws is a fixed jaw which is mounted on the body and the other jaw is engagable with the fixed jaw.

Conveniently the jaws are provided with complementary interengagable formations

which are a push-fit together for interengagement of the jaws.

5 In another embodiment the first jaw has a plurality of spaced-apart hollow posts, an interior of each post forming at least, at a free outer end thereof, a socket for reception of a complementary plug of the second jaw for interengagement of the jaws.

In a further embodiment a plurality of the plugs are mounted spaced-apart on a support ring.

10 In another embodiment the elastic membrane has a plurality of spaced-apart plug receiving holes which are engagable with the plugs to mount the membrane on the plugs.

15 In a further embodiment the body comprises a self-supporting panel forming a top of the pack, a collapsible container body being attached to the panel and forming therewith a closed container for reception and storage of a plurality of wipes. The term "self-supporting panel" means a panel which is stiff enough to hold its shape but may possibly be bent or flexed to a certain degree. Many plastics materials would allow this.

20 In another aspect the invention provides a pack of wipes comprising a container with a plurality of wipes therein having a dispenser as described herein mounted at an outlet opening in a side wall of the container.

25 In another embodiment a plurality of wipes are mounted in the container, said wipes being joined end to end in a continuous web with spaced-apart lines of perforation extending between opposite sides of the web to define the wipes between lines of perforations.

30 In a further embodiment the web is folded in a zig-zag formation in a stack of wipes within the container.

In another embodiment a plurality of folded individual wipes are mounted in the container, adjacent wipes being interleaved to form a stack of interleaved wipes within

the container.

In another embodiment the wipes are impregnated with liquid. Typically the liquid might include one or more of a cleaning agent, a disinfectant and a perfume.

5

The invention will be more clearly understood by the following description of some embodiments thereof given by way of example only, with reference to the accompanying drawings, in which:

10

Fig. 1 is a plan view of a dispenser according to the invention;

Fig. 2 is an underneath plan view of the dispenser;

Fig. 3 is a side elevational view of the dispenser;

15

Fig. 4 is a perspective view of a pack of wipes incorporating the dispenser;

Fig. 5 is a perspective view similar to Fig. 4 showing the dispenser in use for dispensing wipes from the pack;

20

Fig. 6 is a perspective view of a wipes dispenser according to another embodiment of the invention;

Fig. 7 is a sectional view taken along the line VII-VII of Fig. 6;

25

Fig. 8 is a detail perspective view of portion of the wipes dispenser of Fig. 6;

Fig. 9 is a detail sectional elevational view of a dispensing opening portion of the wipes dispenser of Fig. 6;

30

Fig. 10 is an enlarged detail perspective view showing portion of the wipes dispenser of Fig. 6;

Fig. 11 is a detail sectional view taken along the line XI-XI of Fig. 10;

Fig. 12 is a detail sectional view taken along the line XII-XII of Fig. 10,

5 Fig. 13 is a detail perspective view of a panel forming portion of another wipes dispenser according to another embodiment of the invention;

Fig. 14 is an underneath perspective view of the panel shown in Fig. 13;

10 Fig. 15 is a side elevational view of the panel shown in Fig. 13;

Fig. 16 is a detail underneath perspective view showing portion of the panel of Fig. 13; and

15 Fig. 17 is a detail perspective view showing portion of the panel of Fig. 13.

Referring to the drawings and initially to Figs. 1 to 5 thereof there is illustrated a dispenser for a pack of wipes, the dispenser being indicated generally by the reference numeral 1. The dispenser 1 is of a stiff plastics material and has a body 2 with a peripheral mounting flange 3 for attachment to a sidewall 14 of a pack 12 of wipes 10 as shown on Figs. 4 and 5. A tear-open closure 4 is integrally formed with the body 2. A portion of a periphery of the closure 4 is tearable away from the body 2 to leave the closure 4 attached to the body 2 by a hinge 5. The closure 4 is mounted at an opening 7 in the body 2 across which is stretched a silicone membrane 8 having a circular dispensing opening 9 through which wipes 10 are dispensed from a flow-wrap plastics pack 12 of wipes.

20 The closure 4 is defined by the hinge 5 formed along an inner edge of the closure 4 and a generally V-shaped line of weakness 15 formed by reduced material thickness in the body 2 which extends partially around the closure 4, that is around the sides and outer end of the closure 4. Said line of weakness 15 frangibly connects the closure 4 to the body 2 such that it can be peeled away from the body 2 along the line of weakness 15 for hinging about the hinge 5 at an inner end of the closure 4.



- 7 -

Catch means is provided for engaging and holding the closure 4 in an open position to allow dispensing of wipes 10 from the pack 12. In this case the catch means comprises a locking spigot 18 on the body 2 and a complementary receiver slot 19 at a hinge side edge of the closure 4. Thus when the closure 4 is hinged upwardly into an upright position as shown in Fig. 5 the slot 19 engages with the spigot 18 to hold the closure 4 in an open position to provide unrestricted access to the wipes 10 in the pack 12. A tab 20 at an outer end of the closure 4 forms a handgrip which can be gripped between finger and thumb to tear the closure 4 upwardly breaking the line of weakness 15 when initially opening the closure 4 and for subsequent opening and closing of the closure 4. A tongue 21 at an outer end of the closure 4 is engagable under an associated lip 22 at a front end of the opening 7 to lock the closure 4 in a closed position. A cut-out slot 23 in the body 2 above the lip 22 receives the tab 20 when the closure 4 is shut.

The silicone membrane 8 is clamped on an underside of the body 2 by means of a clamp ring 30. The clamp ring 30 has a number of spaced-apart plugs 31 which engage within complementary sockets in tubular posts 32 formed in the body 2 of the dispenser 1. The plugs 31 pass through associated holes in the membrane 8 to engage and clamp the membrane 8 on an underside of the body 2.

The wipes 10 may be arranged in the pack 12 in any suitable fashion. For example the wipes 10 may be joined end to end in a continuous web with spaced-apart lines of perforations extending between opposite sides of the web to define the wipes 10 between lines of perforations. The web may be folded in a zig-zag formation to form a stack of wipes within the pack 12. In an alternative arrangement separate wipes 10 may be interleaved in a stack within the pack 12.

In use, the dispenser 1 is mounted on a sidewall 14 of the pack 12 about an opening in the pack 12. The flange 3 is heat welded, ultrasonic welded or otherwise attached to the sidewall 14 of the pack 12. It will be appreciated that wet wipes 10 can be fully sealed within the pack 12 prior to rupture of the closure 4. To open the pack 12 the tab 20 is gripped and pulled upwardly to break the line 15 of weakness so that the closure 4 can be pivoted upwardly about the hinge 5 into an upright position as shown in Fig. 5 exposing the opening 7 with the silicone membrane 8 and dispensing opening

- 8 -

9 through which wipes 10 can be pulled. After removal of a wipe 10 the cover 4 can be closed over the opening 7 engaging the tongue 21 with the associated lip 22 to hold the closure 4 in the closed position.

5 It will be appreciated that the dispenser 1 according to the invention helps minimise moisture loss from the wipes 10 within the pack 12. Due to its elasticity the silicone membrane 8 effectively seals the interior of the pack 12 preventing moisture loss. While a tip of the uppermost wipe 10 will extend through the opening 9 this is protected against moisture loss by virtue of the closure 4. A double barrier against  
10 moisture loss is thus provided by the closure 4 and the silicone membrane 8.

If desired, the pack 12 may be provided with an uppermost wipe 10 primed through the opening 9 in the silicone membrane 8 ready for use. Even if when dispensing a wipe 10 the next wipe 10 is not fed into the opening 9, a user can readily easily insert a  
15 finger through the opening 9 to grip and pull through the next wipe 10.

It will be appreciated that the invention is particularly useful for collapsible plastics packs such as flow-wrapped packs. The body of the dispenser is preferably also of plastics material. Ideally the body will be self-supporting, that is substantially stiff to  
20 hold its shape but also somewhat flexible.

Various ways of forming the resiliently deformable wipe dispensing opening may be provided. For example said dispensing opening may be formed by mounting a separate grommet, strip or membrane of elastic material such as silicone or rubber at  
25 an outlet opening of the container. Alternatively, if desired the material of the container about a periphery of the opening may be constructed and/or treated to render it sufficiently flexible and elastic to form the desired dispensing opening. This treatment could conveniently be effected during the moulding process where the dispenser body is constructed of plastics material.

30

Referring now to Figs. 6 to 12 there is illustrated another wipes dispenser according to another embodiment of the invention indicated generally by the reference numeral 50. The wipes dispenser 50 has a self-supporting dispensing panel 52 of plastics material. This will bend and flex a certain amount but is generally speaking rigid enough to hold

- 9 -

its shape. A collapsible container body 53 of plastics material is attached to the dispensing panel 52 and forms together with the dispensing panel 52 a closed container for reception and storage of a plurality of wipes 54. A dispensing opening 55 is provided in the dispensing panel 52 through which the wipes 54 can be drawn for discharge from the dispenser 50. A silicone membrane 56 is mounted across the dispensing opening 55. A through hole 57 in the silicone membrane 56 allows through passage of a wipe 54 for dispensing the wipes 54 from the container body 53 in a controlled manner. A hinged cover 58 is mounted on the panel 52. The cover 58 is movable between a closed position (Fig. 6) in which said cover 58 seals the dispensing opening 55 and an open position (Fig. 7) allowing access to the dispensing opening 55 for discharge of wipes 54 from the container body 53.

The dispensing panel 52 has a peripheral flange 60. An upper rim of the collapsible container body 53 is welded to an underside of the flange 60 to form together with the dispensing panel 52 a closed container for the wipes 54. The cover 58 is integrally formed with the dispensing panel 52 and is a tear-away cover. An inner edge 62 of the cover 58 forms a hinge connection between the cover 58 and the dispensing panel 52. Side edges 64, 65 of the cover 58 are connected to the dispensing panel 52 by lines of weakness 66 (Fig. 9) of reduced material thickness. A tab 68 at an outer end of the cover 58 forms a hand grip which can be gripped between finger and thumb to tear the cover 58 upwardly breaking the lines of weakness 66 when initially opening the dispenser 50. Thereafter, when closing the cover 58 the tab 68 engages with a complementary receiver 70 (Fig. 10) in the flange 60 of the dispensing panel 52 to secure the cover 58 in a closed position.

The mounting of the silicone membrane 56 on the dispensing panel 52 is shown in more detail in Fig. 9. An inwardly extending endless wall 75 projects inwardly from an inside face of the dispensing panel 52 about a periphery of the dispensing opening 55. A channel 76 is provided in the wall 75 for reception of a complementary bulbous edge portion 77 of the silicone membrane 56.

Referring to Fig. 7, a plurality of wipes 54 are mounted in the container body 53 joined end to end in a continuous web with spaced-apart lines of perforations extending between opposite sides of the web to define the wipes between lines of perforations.

- 10 -

The web is folded in a zig-zag formation to form a stack of wipes within the container body 53 as shown.

5 In use, the tab 68 of the cover 58 is gripped and the cover 58 is torn away from the dispensing panel 52 along the lines of weakness 66. A leading wipe 54 is drawn through the opening 57 in the silicone membrane 56 and pulled away from the web along the line of perforations. It will be noted that the silicone membrane 56 clamps about the leading edge of the wipe 54 to seal the container preventing loss of moisture from the wipes 54. Also the silicone membrane 56 holds the next wipe 54 in place  
10 ready for gripping and removal by the next user. The cover 58 when closed also provides protection against moisture loss. Gradually as the wipes are discharged from the dispenser 50 the container body 53 will collapse for compactness. Further, because the container body 53 is flexible the dispenser 50 is more readily portable than a rigid dispenser container. This considerable advantage is provided by the  
15 dispenser of the invention having a rigid or semi rigid dispensing panel with the collapsible container body. All the corners and sharp edges on the dispenser panel 52 are rounded to avoid injury or finger traps even for infants and toddlers. The dispenser 50 can be sold with the uppermost wipe 54 primed through the opening 57 in the silicone membrane 56 ready for use. Even if a wipe should break off within the  
20 container body 53 a user can readily easily insert fingers to draw out a leading edge of the uppermost wipe for dispensing due to the elasticity of the silicone membrane 56. Further, and again due to its elasticity, the silicone membrane 56 effectively seals the interior of the container body 53 preventing moisture loss. While a tip of the uppermost wipe 54 will extend through the opening 57 this is protected against  
25 moisture loss by closure of the cover 58. So a double barrier against moisture loss is provided by the cover 58 and silicone membrane 56. From a manufacturing point of view the dispenser 50 is relatively simple and cheap to manufacture, merely comprising three parts, namely the dispenser panel 52, the container body 53 and the silicone membrane 56.

30 Referring now to Figs. 13 to 17 there is shown another wipes dispenser indicated generally by the reference numeral 80. This is largely similar to the wipes dispenser described previously in Figs. 6 to 12 and like parts are assigned the same reference numerals. The collapsible container body 53 is shown in broken outline in Fig. 13. In

this case the silicone membrane is secured on an inside of the dispensing panel 52 by clamp means indicated generally by the reference numeral 82. The clamp means 82 has a complementary pair of clamp jaws, namely a first jaw 83 and a second jaw 84 which are interengagable to clamp the elastic membrane (not shown) therebetween and across the dispensing opening 55. The first jaw 83 comprises a plurality of spaced-apart tubular posts 85 which project outwardly from an inside face of the dispensing panel 52. The posts 85 are arranged around the dispensing opening 55 and are interconnected by a wall 86 which projects outwardly from the inside face of the dispensing panel 52 and surrounds the dispensing opening 55. The second jaw 84 comprises a plurality of plugs 88, best seen in Fig. 17, which are mounted spaced-apart on a support ring 89 which interconnects the plugs 88. Each plug 88 has a cylindrical body 90 with a flanged outer end 91. An inner end 92 of the plug 88 is tapered to facilitate guiding the plug 88 into engagement with a complementary socket 94 (Fig. 16) formed by an interior of each post 88 of the first jaw 83.

The elastic membrane has a plurality of spaced-apart plug receiving holes which correspond with and receive the plugs 88 to mount the membrane on the plugs 88. The plugs 88 are then inserted in the associated sockets 94 in the posts 85 to clamp the membrane between the first jaw 83 and second jaw 84 securing the membrane across the dispensing opening 55.

*It will be appreciated that the flexible dispensing opening minimises the moisture loss from the wipes. The resiliently deformable wet wipe dispensing opening may be formed by mounting a separate grommet, strip or membrane of elastic material such as silicone or rubber at an outlet opening of the container.*

The wipes dispensers of the invention are conveniently heat welded onto a flexible substrate forming a collapsible container for the wipes.

The invention is not limited to the embodiments hereinbefore described which may be varied in both construction and detail within the scope of the appended claims.

**CLAIMS**

1. A dispenser (1) for a pack (12) of wipes (10), including a stiff body (2) having a mounting flange (3) for attachment to a side wall of the pack (12) about an outlet opening in said side wall, a wipes dispensing opening (7) in the body (2) for co-operation with the outlet in the side wall of the pack (12) to allow dispensing of wipes (10) from the pack (12), and a tear-open closure (4) which is integrally formed with the body (2) and extends across the dispensing opening (7) to close the dispensing opening (7), a portion (15) of a periphery of the closure (4) being tearable away from the body (2) to leave the closure (4) attached to the body (2) by a hinge (5), an elastic membrane (8) being mounted on the body (2) inside the closure (4) extending across the dispensing opening (7), the elastic membrane (8) having a through hole (9) for reception and through passage of a wipe (10) for dispensing wipes (10) from the pack (12).
2. A dispenser as claimed in claim 1 wherein the closure (4) is defined by lines of weakness (15) formed by reduced material thickness in the body (2) which extend partially around the closure (4) terminating at a hinge (5) edge of the closure (4), said lines of weakness (15) frangibly connecting the closure (4) to the body (2) such that it can be peeled away from the body (2) along the lines of weakness (15) for hinging about the hinge (5) at an inner edge of the closure (4).
3. A dispenser (50) as claimed in any preceding claim wherein the body comprises a self-supporting panel (52) forming a top of the pack, a collapsible container body (53) being attached to the panel (52) and forming therewith a closed container for reception and storage of a plurality of wipes (54).
4. A dispenser as claimed in any preceding claim wherein clamp means (30) is provided for attachment of the elastic membrane (8) to the body (2) of the dispenser (1).
5. A dispenser as claimed in claim 4 wherein the clamp means comprises a

- 13 -

complementary pair of clamp jaws, namely a first jaw and a second jaw, said jaws being interengagable to clamp the elastic membrane therebetween.

- 5
6. A dispenser as claimed in claim 5 wherein one of said jaws is a fixed jaw which is mounted on the body and the other jaw is engagable with the fixed jaw.
7. A dispenser a claimed in claim 5 wherein the jaws are provided with complementary interengagable formations which are a push-fit together for interengagement of the jaws.
- 10
8. A dispenser as claimed in claim 7 wherein the first jaw has a plurality of spaced-apart hollow posts, an interior of each post forming at least at a free outer end thereof a socket for reception of a complementary plug of the second jaw for interengagement of the jaws.
- 15
9. A dispenser as claimed in claim 8 wherein a plurality of the plugs are mounted spaced-apart on a support ring.
- 20
10. A dispenser as claimed in claim 8 wherein the elastic membrane has a plurality of spaced-apart plug receiving holes which are engagable with the plugs to mount the membrane on the plugs.

AWPS02801Prelim 18/010.03.03

25

30

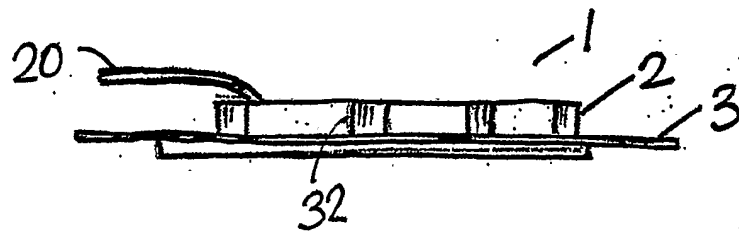

FIG 3

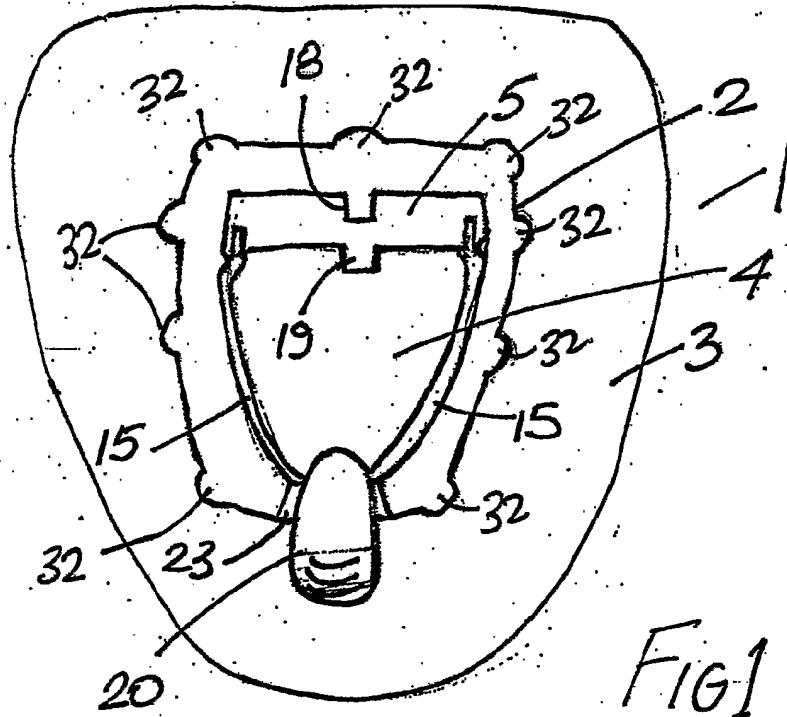

FIG 1

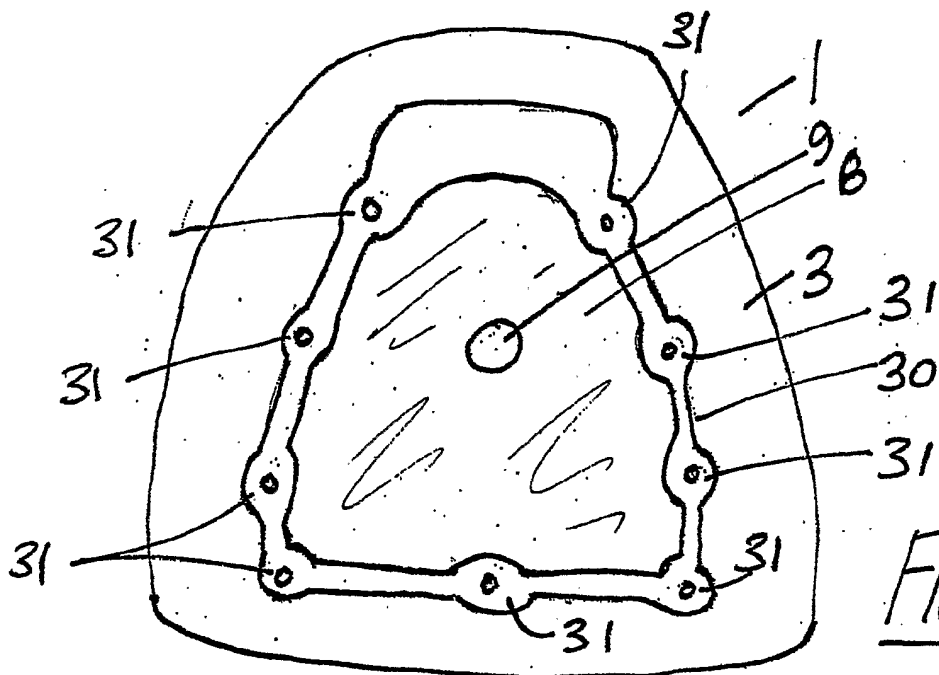

FIG 2



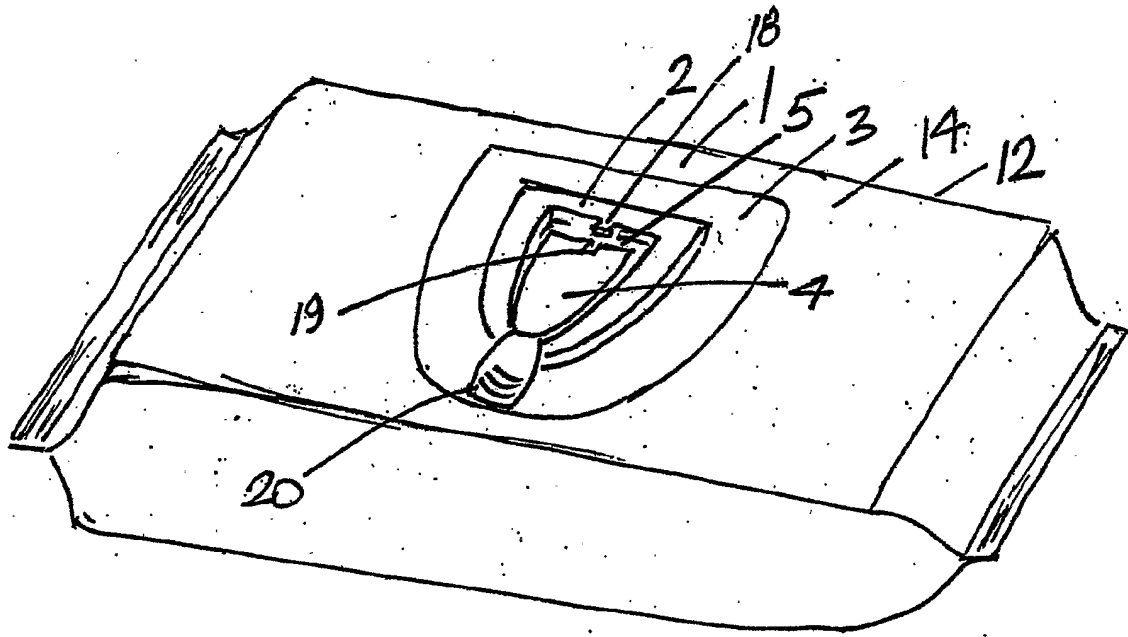

FIG 4

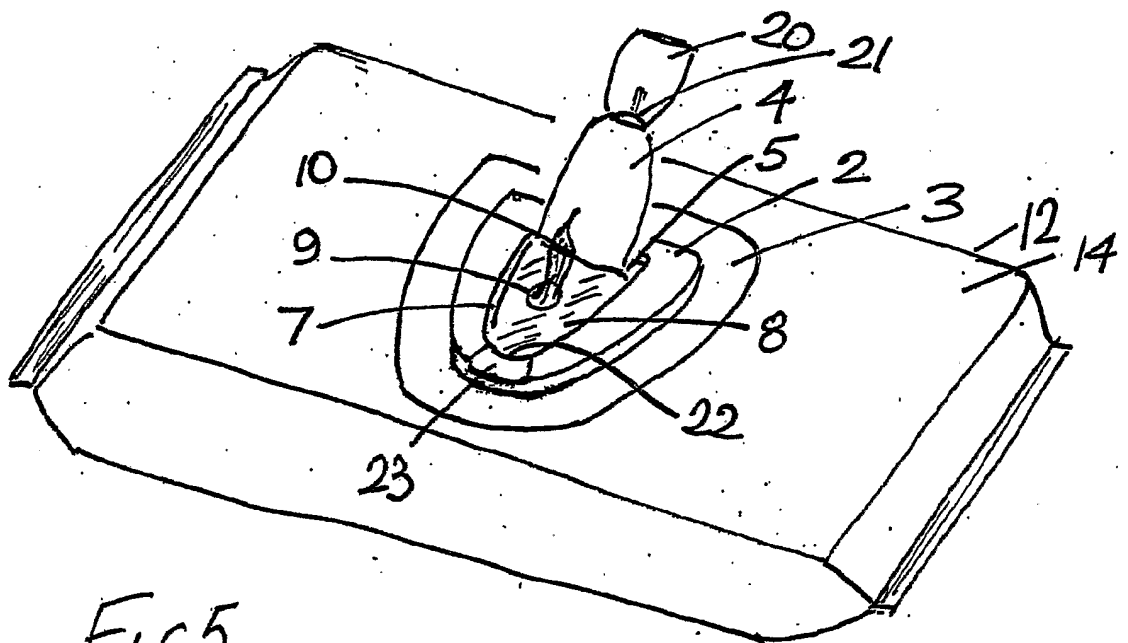

FIG 5

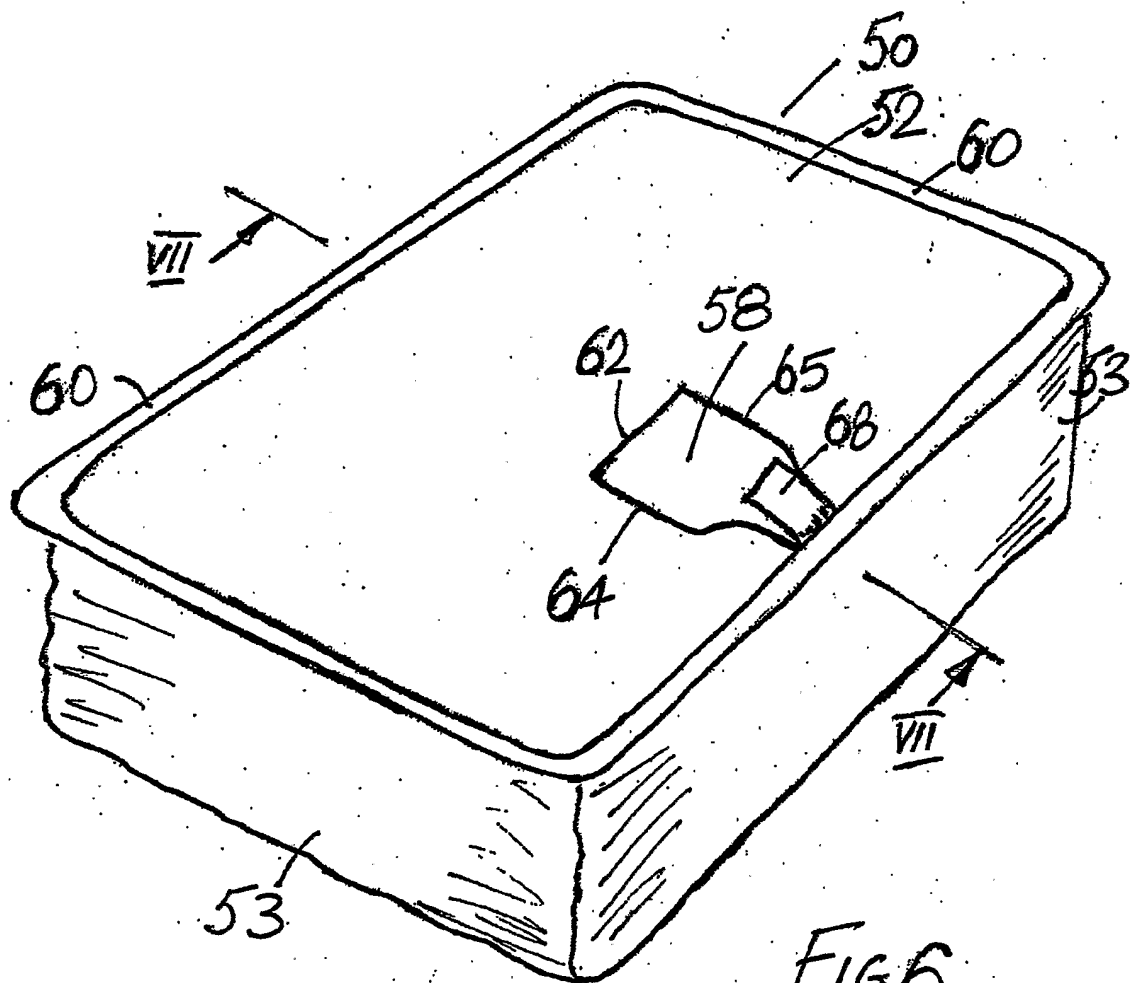

FIG 6

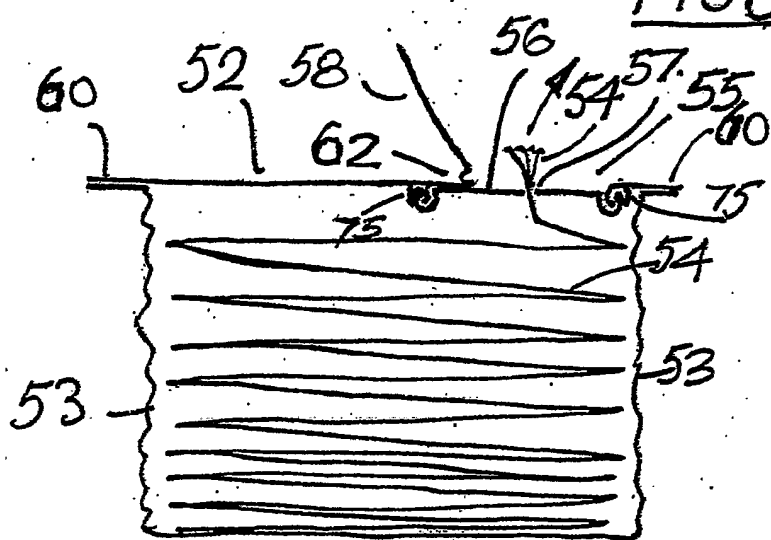
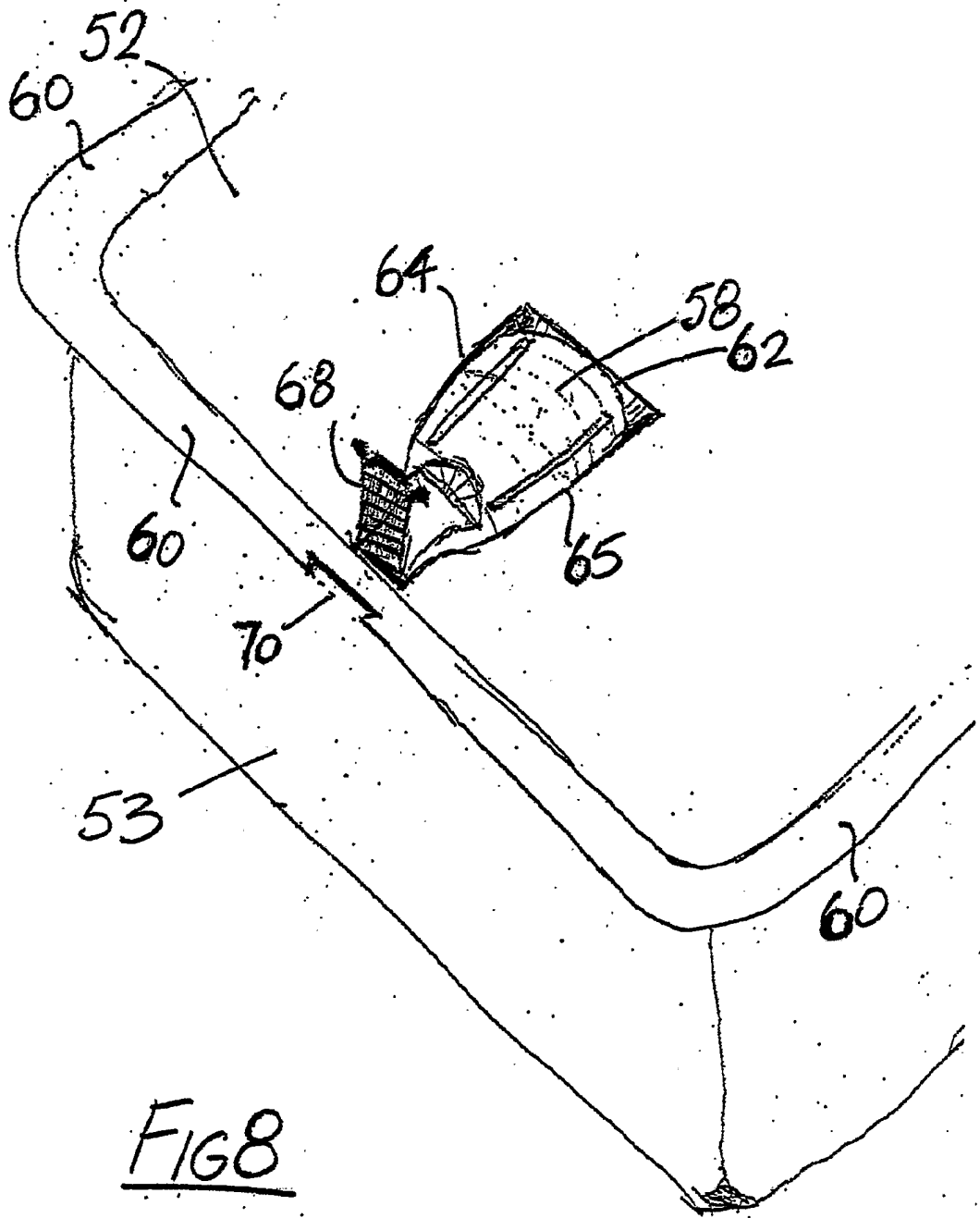
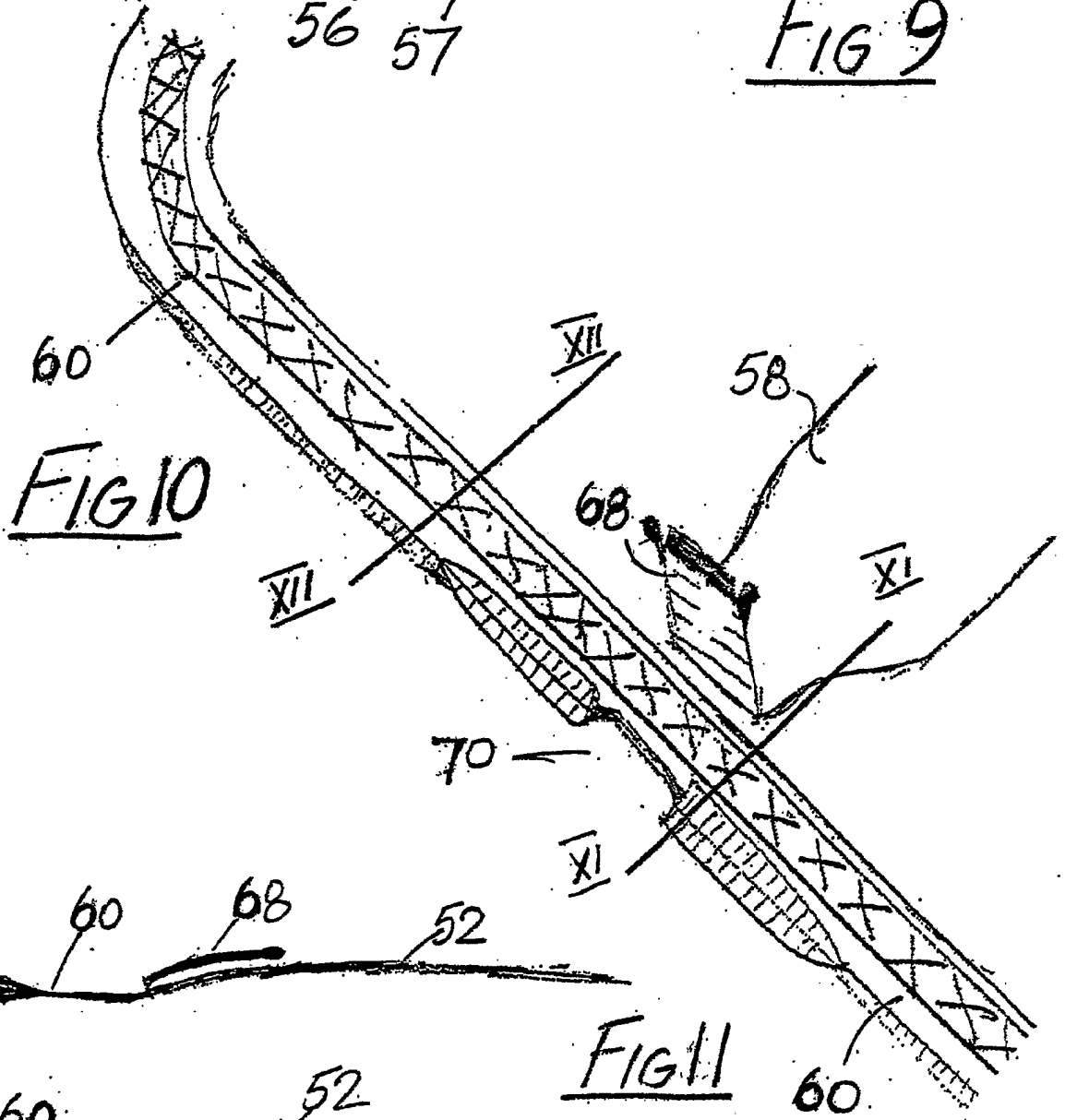
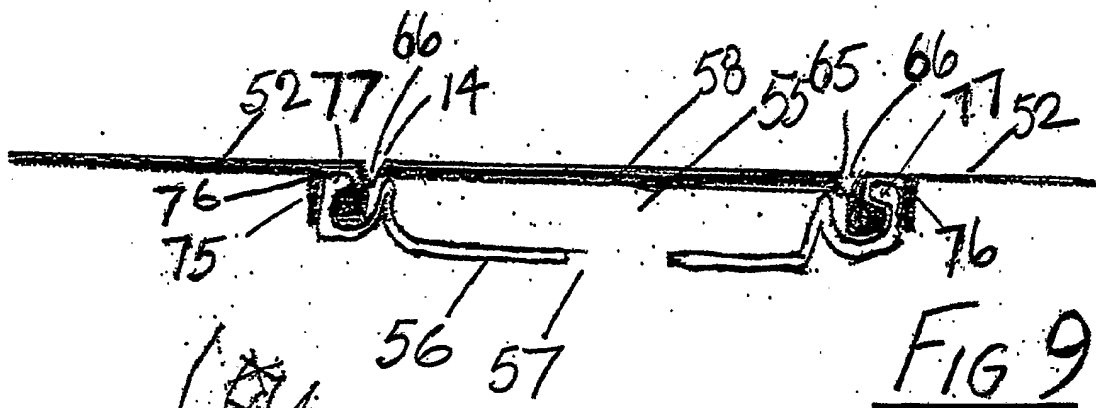

FIG 7





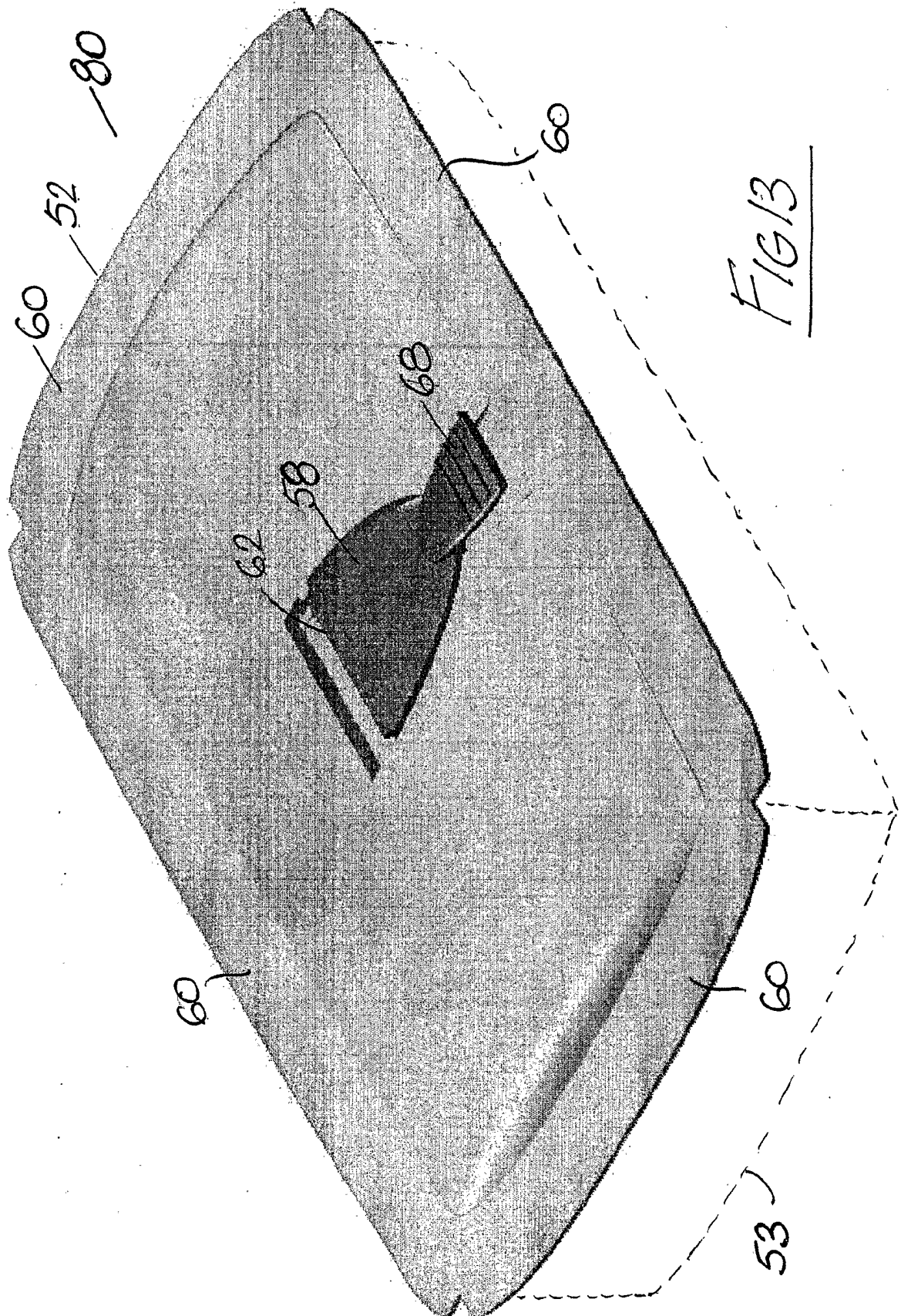
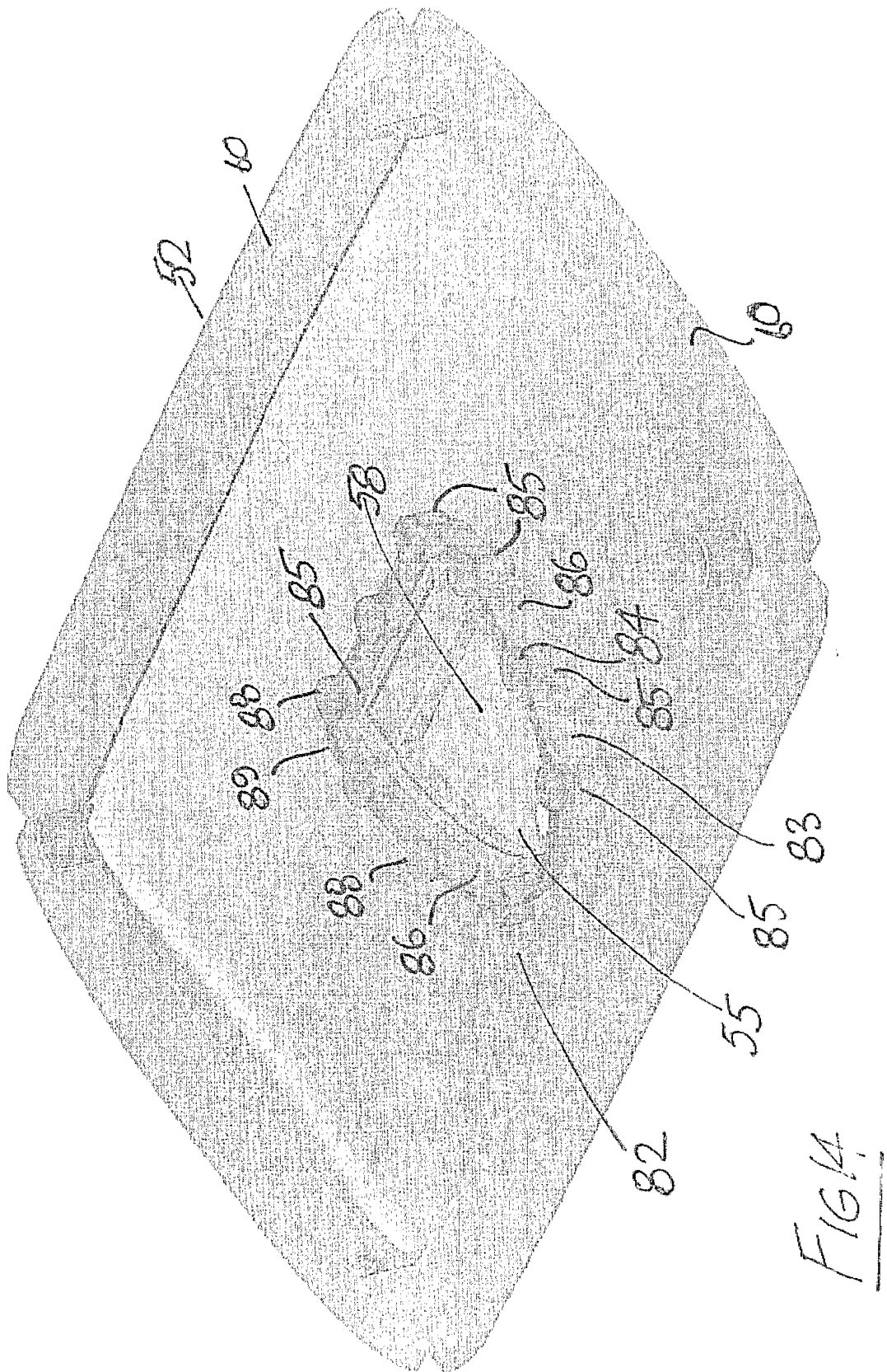

FIG 13



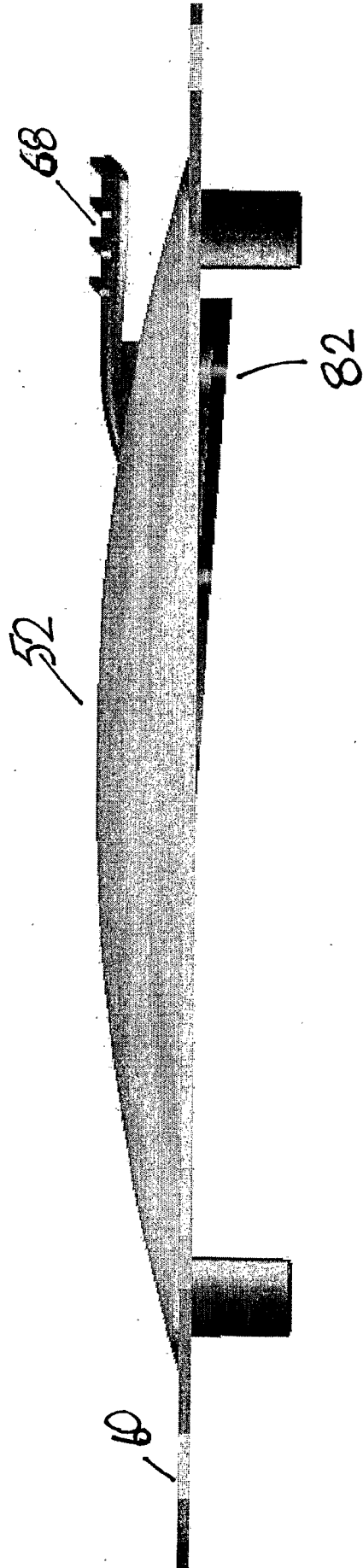

FIG 15

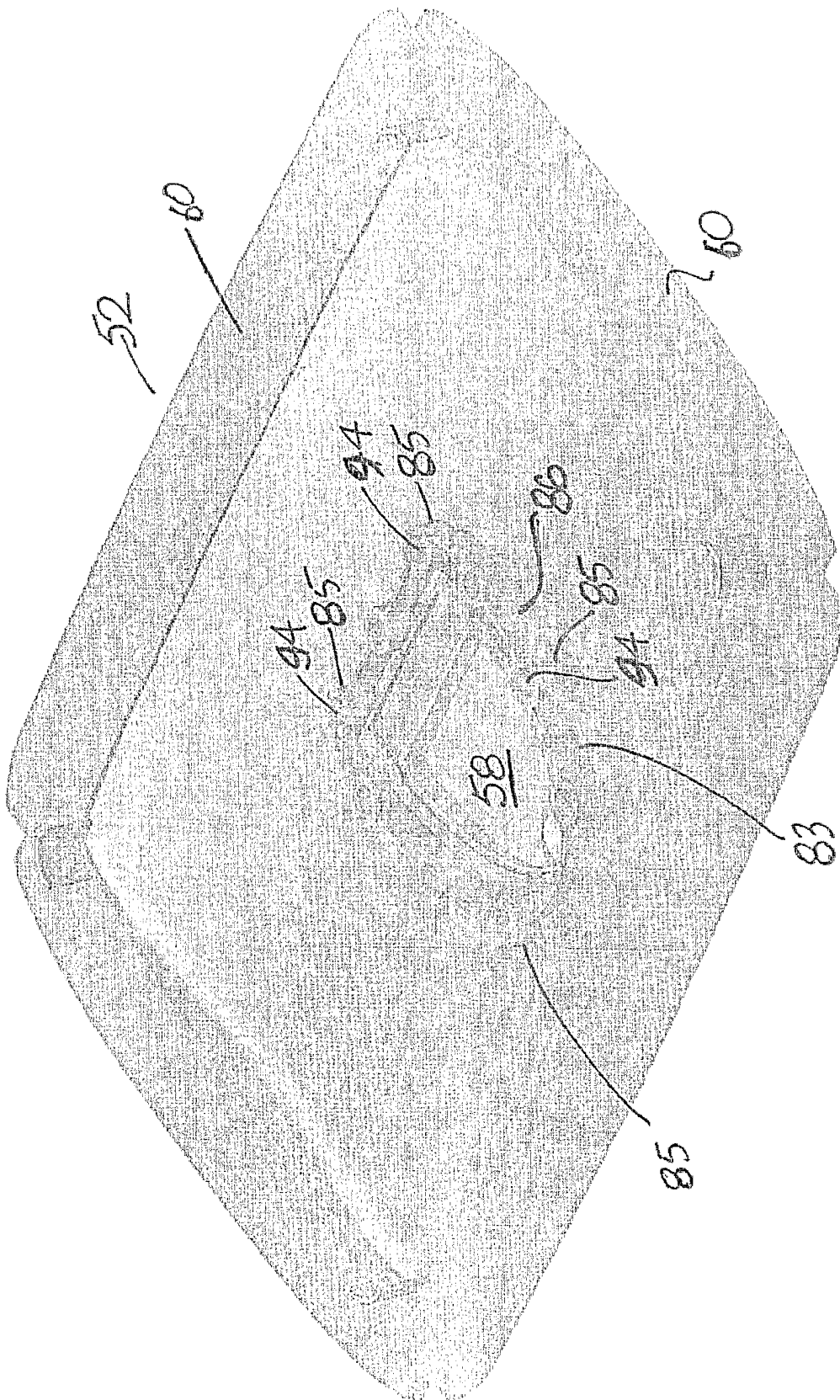

FIG 16



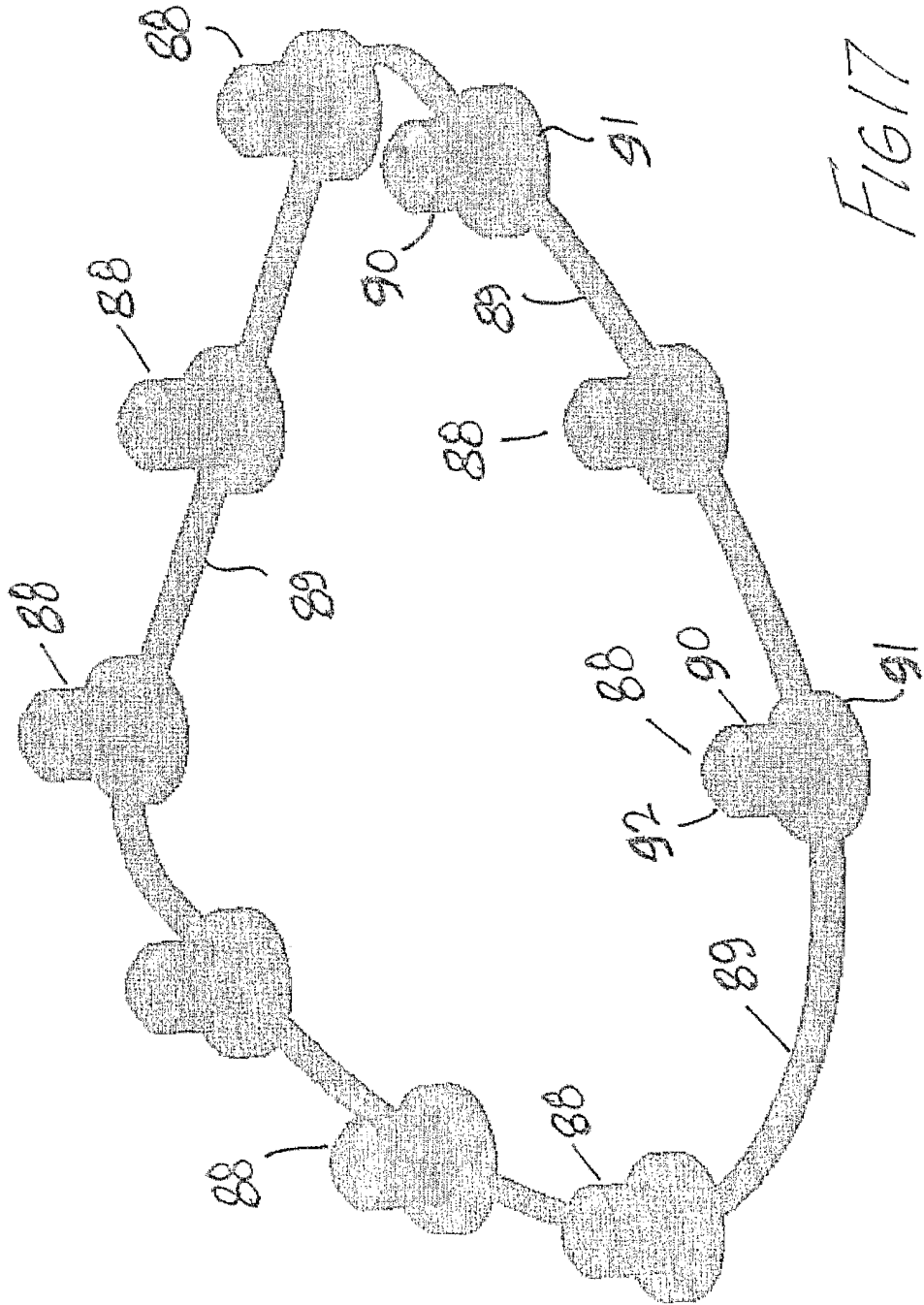

FIG 17

## INTERNATIONAL SEARCH REPORT

International Application No

PCT/IE 03/00039

**A. CLASSIFICATION OF SUBJECT MATTER**

IPC 7 B65D75/58 B65D83/08

According to International Patent Classification (IPC) or to both national classification and IPC

**B. FIELDS SEARCHED**

Minimum documentation searched (classification system followed by classification symbols)

IPC 7 B65D A47K

Documentation searched other than minimum documentation to the extent that such documents are included in the fields searched

Electronic data base consulted during the international search (name of data base and, where practical, search terms used)

EPO-Internal

**C. DOCUMENTS CONSIDERED TO BE RELEVANT**

Category °	Citation of document, with indication, where appropriate, of the relevant passages	Relevant to claim No.
X	DE 93 17 973 U (BRAEM GUENTHER) 23 June 1994 (1994-06-23)	1,2
A	the whole document	3-10
	---	
X	WO 01 74687 A (KIMBERLY CLARK CO) 11 October 2001 (2001-10-11)	1,2
A	the whole document	3-10
	---	
A,P	US 6 439 429 B1 (GROSS RICHARD A) 27 August 2002 (2002-08-27)	1,3-10
	the whole document	
	---	
A	WO 00 64755 A (SORRENTINO GIOVAMBATTISTA ; CONVERTING WET WIPES S R L (IT)) 2 November 2000 (2000-11-02)	1-10
	the whole document	
	---	
	-/--	

 Further documents are listed in the continuation of box C. Patent family members are listed in annex.

## ° Special categories of cited documents:

\*A\* document defining the general state of the art which is not considered to be of particular relevance

\*E\* earlier document but published on or after the international filing date

\*L\* document which may throw doubts on priority claim(s) or which is cited to establish the publication date of another citation or other special reason (as specified)

\*O\* document referring to an oral disclosure, use, exhibition or other means

\*P\* document published prior to the international filing date but later than the priority date claimed

\*T\* later document published after the international filing date or priority date and not in conflict with the application but cited to understand the principle or theory underlying the invention

\*X\* document of particular relevance; the claimed invention cannot be considered novel or cannot be considered to involve an inventive step when the document is taken alone

\*Y\* document of particular relevance; the claimed invention cannot be considered to involve an inventive step when the document is combined with one or more other such documents, such combination being obvious to a person skilled in the art.

\*&amp;\* document member of the same patent family

Date of the actual completion of the international search

18 June 2003

Date of mailing of the international search report

26/06/2003

Name and mailing address of the ISA

European Patent Office, P.B. 5818 Patentlaan 2  
NL - 2280 HV Rijswijk  
Tel. (+31-70) 340-2040, Tx. 31 651 epo nl,  
Fax: (+31-70) 340-3016

Authorized officer

Pernice, C

## INTERNATIONAL SEARCH REPORT

International Application No  
PCT/IE 03/00039

## C.(Continuation) DOCUMENTS CONSIDERED TO BE RELEVANT

Category °	Citation of document, with indication, where appropriate, of the relevant passages	Relevant to claim No.
A	EP 0 930 243 A (ALBAAD MASSUOT YITZHAK LIMITED) 21 July 1999 (1999-07-21) the whole document ---	1-10
A	EP 0 760 343 A (YAMADA CHIYOE) 5 March 1997 (1997-03-05) the whole document -----	1-10

## INTERNATIONAL SEARCH REPORT

International Application No

PCT/IE 03/00039

Patent document cited in search report		Publication date	Patent family member(s)	Publication date
DE 9317973	U	23-06-1994	DE 9317973 U1	23-06-1994
WO 0174687	A	11-10-2001	US 6523690 B1 AU 4963101 A BR 0109717 A CA 2399249 A1 CN 1418166 T EP 1268308 A1 WO 0174687 A1	25-02-2003 15-10-2001 04-02-2003 11-10-2001 14-05-2003 02-01-2003 11-10-2001
US 6439429	B1	27-08-2002	WO 03004361 A2	16-01-2003
WO 0064755	A	02-11-2000	IT MI990889 A1 IT MI990497 U1 AU 5062400 A WO 0064755 A2	27-10-2000 05-02-2001 10-11-2000 02-11-2000
EP 0930243	A	21-07-1999	IL 123003 A EP 0930243 A1	31-01-2000 21-07-1999
EP 0760343	A	05-03-1997	AU 4956696 A EP 0760343 A1 GB 2304098 A LU 88847 A1 NO 965135 A CA 2191468 A1 WO 9631411 A1 JP 3172938 B2 JP 8337276 A ZA 9602664 A	23-10-1996 05-03-1997 12-03-1997 15-04-1997 24-01-1997 10-10-1996 10-10-1996 04-06-2001 24-12-1996 09-10-1996