

No. 676,471.

Patented June 18, 1901.

A. C. PESSANO.
JOURNAL BOX.
(Application filed Dec. 13, 1900.)

(No Model.)

Fig. 1.

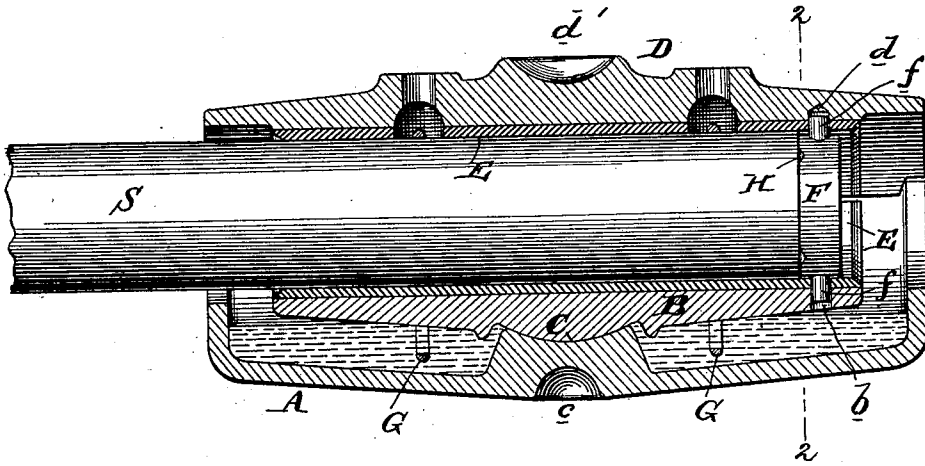

Fig. 2.

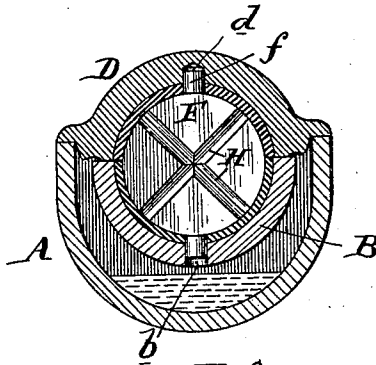
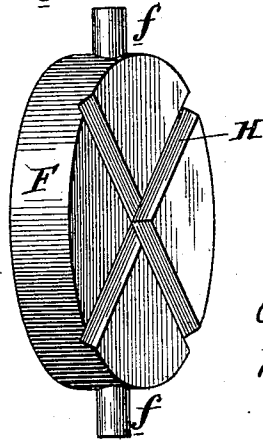

Fig. 3.



Witnesses:
H. B. Hallock.
R. M. Kelly.

Inventor
Antonio C. Pessano
By *[Signature]*
Atty.

UNITED STATES PATENT OFFICE.

ANTONIO C. PESSANO, OF PHILADELPHIA, PENNSYLVANIA, ASSIGNOR TO
THE GEORGE V. CRESSON COMPANY, OF PENNSYLVANIA.

JOURNAL-BOX.

SPECIFICATION forming part of Letters Patent No. 676,471, dated June 18, 1901.

Application filed December 13, 1900. Serial No. 39,593. (No model.)

To all whom it may concern:

Be it known that I, ANTONIO C. PESSANO, of Philadelphia, (Mount Airy,) Pennsylvania, have invented an Improvement in Journal-Boxes, of which the following is a specification.

My invention has reference to journal-boxes; and it consists of certain improvements, all of which are fully set forth in the following specification and shown in the accompanying drawings, which form a part thereof.

Heretofore it has been customary in using the usual types of shaft-hangers on the market for short shafts, as in counter-shafts, to employ collars on the shafts outside of the journal-bearing, held in place by set-screws to prevent the shaft from shifting longitudinally. This construction is considered undesirable, especially in textile mills, where lint and textile fiber generally are floating in the atmosphere, as they become tangled about the collars and interfere with the proper running of the bearings and also cause the oil to be extracted from the box. They are, furthermore, unsightly, and the collars are liable to become loose and the shaft displaced.

The object of my invention is to provide the ordinary type of journal-box for shafting—such, for example, as shown in my patent No. 654,276, dated July 24, 1900—with a step or thrust bearing normally held in place between the upper and lower portions of the box by pins, and thereby furnish a bearing against which the end of the shaft may work while otherwise working in the journal-bearing. In this construction no collars or screws are employed, and the shaft is shorter and presents no undesirable projecting portions adapted to catch the floating fiber. In adapting my invention to a journal-box of this construction it is only necessary to provide a metal thrust-disk of the diameter of the shaft and provide it with short pins, which enter holes in the top and bottom portions of the box. Persons having the usual shaft-hangers may adapt them to my invention by simply boring two holes, as above mentioned, and introducing the small disks, which may be ordered and transmitted by mail. The

construction is far simpler, cheaper, more ornamental and more desirable than the use of collars such as heretofore used.

My invention will be better understood by reference to the drawings, in which—

Figure 1 is a longitudinal sectional elevation of a journal-box embodying my invention. Fig. 2 is a cross-section of same on line 2 2, and Fig. 3 is a perspective view of the thrust block or disk removed from the box.

A is the lower or oil box and supports upon the curved seat C the lower adjustable half B of the journal-bearing.

D is the upper half of the journal-bearing and rests upon the lower part B and is adapted to be clamped by the usual screws, (not shown,) which respectively press downward into the socket *d* of part D and upward into the socket *c* in the bottom of the part A.

G represents oiling-rings of the usual construction.

Located near one end of the journal-bearing E, formed by the parts B and D, I place a disk F, which preferably effectually closes the said bearing and acts as a thrust-bearing against which the end of the shaft S works. This disk F is provided with two pins *ff*, one of which projects upwardly into a hole *d* in the part D and the other downwardly into a hole *b* in the part B. In this manner the disk is supported, as it were, in trunnions movable on a vertical axis, and consequently adjusts and adapts itself to the end of the shaft. If desired, the working face of the disk F may have small grooves H formed therein to enable the proper circulation of the lubricant. It will now be seen that it is a very easy matter to convert a line-shaft bearing into a counter-shaft bearing and that this may be readily done where the mill has practically no facilities for doing machine-work by simply ordering the disk or part shown in Fig. 3 and then boring the two holes *d* and *b*, which may be done by the most ordinary mechanic with the most simple tools. It thus enables a mill-owner to order the necessary hangers and boxes and adapt them at the mill to such counter-shaft work as may be necessary when erecting the work.

While I prefer the construction shown as excellently adapted to the purpose of my in-

vention, I do not confine myself to the minor details, as these may be modified without departing from the spirit of the invention.

Having now described my invention, what I claim as new, and desire to secure by Letters Patent, is—

1. In a journal-box the combination of the upper and lower parts of the box, with a disk arranged between them and transversely across the bearing thereof and having oppositely-directed pins or studs received in holes in the internal bearing-faces in the said upper and lower parts of the box, whereby the clamping together of the two parts of the box secures the thrust-bearing disk in place.

2. An end-thrust bearing for a journal-box consisting of a circular disk *F* of substantially uniform thickness having two flat parallel faces and provided with oppositely-directed round pins or studs *f, f*, projecting

from diametrically opposite edges and disposed intermediate of the two flat faces of the bearing.

3. A journal-box having radial holes through the inner face of the bearing near one end, combined with a disk of smaller diameter than the diameter of the journal-bearing and provided with radial pins or projecting parts adapted to fit into the radial holes in the bearing whereby it is held in place therein near one end so as to present a thrust-face substantially at right angles to the axis of the journal-bearing.

In testimony of which invention I have hereunto set my hand.

ANTONIO C. PESSANO.

Witnesses:

R. M. HUNTER,

J. W. KENWORTHY.