

July 26, 1960

F. MARTIN

2,946,920

LIGHTNING ARRESTERS FOR VERY HIGH VOLTAGE

Filed June 30, 1959

3 Sheets-Sheet 1

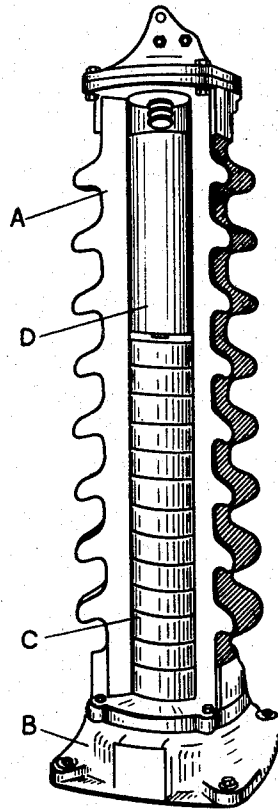

Fig. 1

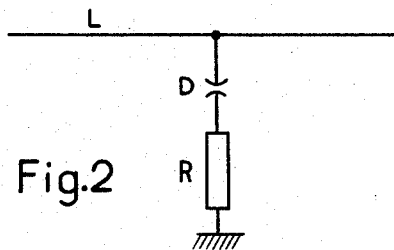

Fig. 2



July 26, 1960

F. MARTIN

2,946,920

LIGHTNING ARRESTERS FOR VERY HIGH VOLTAGE

Filed June 30, 1959

3 Sheets-Sheet 3

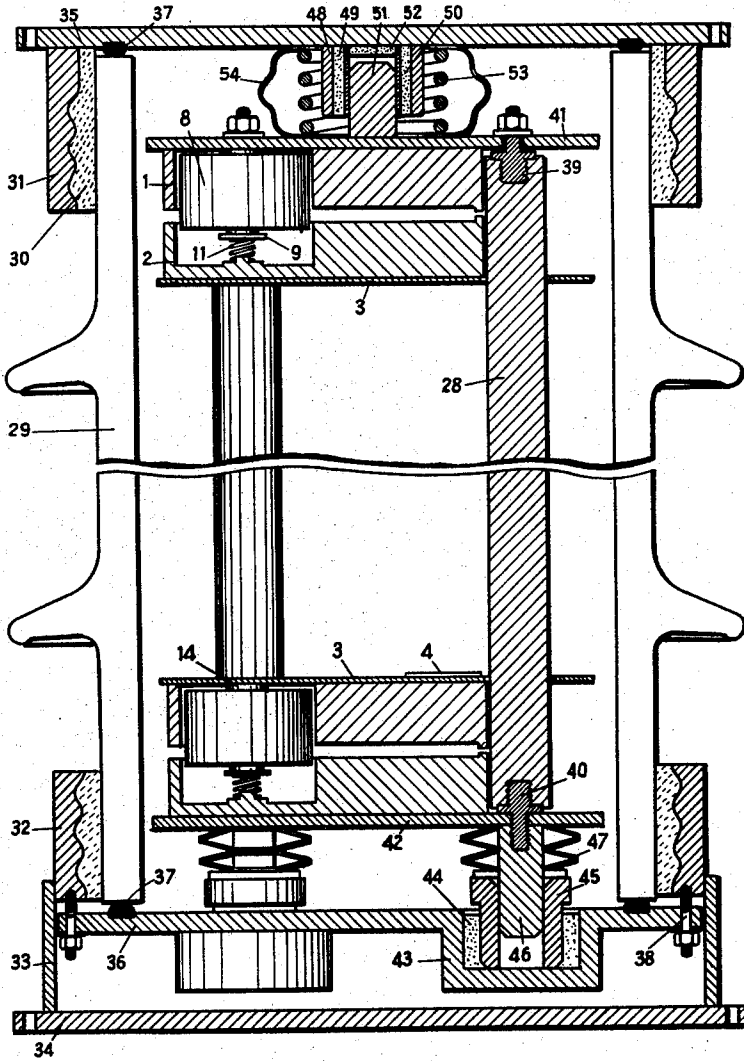

Fig. 5

1

2,946,920

**LIGHTNING ARRESTERS FOR VERY HIGH VOLTAGE**

Fernand Martin, Roux, Belgium, assignor to Ateliers de Constructions Electriques de Charleroi, Brussels, Belgium, a corporation of Belgium

Filed June 30, 1959, Ser. No. 824,040

Claims priority, application France July 7, 1958

6 Claims. (Cl. 315-58)

This invention relates to lightning arresters for very high voltages.

Lightning arresters are already known consisting of a discharge gap in series with a resistance of the non-linear type, of which the resistivity becomes lower in proportion as the voltage across its terminals rises. Such lightning arresters generally take the form of a column consisting of a stack of blocks of variable resistance, surmounted by a discharger constituted by a number of spark gaps in series. The number of resistant blocks, as well as the characteristics of the discharger, depend upon the service voltage. When the latter is very high (for example, 300 kilovolts between line and ground) it is not possible to construct the lightning arrester in a single column; there would be obtained an apparatus of too great a height in relation to its diameter, which apart from the difficulties of construction, would render it fragile and cumbersome. It is therefore necessary to construct the lightning arrester by columns separated in series, of which the assembly is sometimes complicated, expensive and cumbersome.

The present invention eliminates these inconveniences and relates to an improved lightning arrester which can be constructed in a single column, even for very high voltages.

The improved lightning arrester, constituted by a stack of similar elements forming a single column, is characterized in that each of said elements comprises a metallic plate and a casing superposed thereon. The casing is made of insulating material and contains at least one discharger block and at least one block made of material having a resistivity varying with the voltage. Preferably the casing contains one discharger block and two blocks of material having a resistivity varying with the voltage, the three blocks are disposed at the three corners of a triangle and have their axes perpendicular to said metallic plate. The first block of varying resistance is in contact with the metallic plate through an opening formed in the lower cheek or cover of the casing, the upper surfaces of the two blocks of varying resistivity being connected electrically together, the lower surfaces of the second block of varying resistivity and of the discharger block being connected electrically together, and the upper electrode of the discharger block emerges from the upper cheek or cover through an opening formed in the latter so as to be able to make contact with the element next superposed.

The invention is hereinafter described with reference to the accompanying drawings, in which:

Fig. 1 is an example of the known lightning arrester in the form of a column, Fig. 2 is a corresponding diagram.

Fig. 3 is an exploded view of a lightning arrester element according to the invention.

Fig. 4 is a fragmentary view of this element in an assembled condition.

Fig. 5 is an axial section of a lightning arrester constructed with the improved elements.

2

Fig. 1 illustrates a known type of lightning arrester in the form of a column, comprising a hollow insulator A, fixed upon a base B, and containing a stack of blocks C of resistance varying with the applied voltage and composed of grains of silicon carbide agglomerated by a binder and moulded under pressure. This stack is surmounted by a discharger block D, constituted by a certain number of spark gaps in series.

The equivalent diagram of the apparatus is represented in Fig. 2, in which the discharger D is in series with the resistance R formed by the assembly of the blocks C, the circuit thus constituted is interposed between a line L to be protected and the ground. This type of arrester has certain disadvantages, as explained above, in the case of very high line voltages.

Fig. 3 illustrates a constituent element of a lightning arrester according to the present invention, which comprises a casing formed by two symmetrical members or covers 1 and 2 made of insulating material, a metallic plate 3 provided with a boss or thickened portion 4 and having near its periphery three holes such as 5 is disposed axially spaced from two cylindrical blocks 6 and 7 made of material of which the resistivity varies with the voltage applied between their parallel faces, a discharge block 8 composed of spark gaps in series encased for example in a moulded insulating material, two contact members 9 and 10 and springs 11, 12 and 13. These different parts are assembled by bringing them together as indicated by the chain lines.

The discharge block 8 may be of any suitable composition; it is provided with electrodes such as 14 at its extremities. The contact member 10 carries small claws or points 15 which serve to hold the springs 12 and 13 in place.

The cover 1 is formed with an opening 16 adapted to receive the discharger block 8, and two hollow spaces or recesses 17 and 18 accommodate respectively the two resistant blocks 6 and 7. In the bottom of these recesses, there are situated pegs or posts 19 and 20 upon which the springs 12 and 13 are threaded respectively, having first been fixed upon the contact member 10 which serves to connect the blocks 6 and 7 electrically with one another.

The cover 2 is provided with an opening 21 adapted to receive the block 6 which rests upon the boss or thickening 4 of the plate 3, which puts it in electrical contact with the latter. This cheek or cover 2 comprises also two hollows 22 and 23 which receive respectively the discharger block 8 and the resistant block 7. At the bottom of the hollow 22, a peg or post 24 serves as axial support to the spring 11, while at the bottom of the hollow 23, there is provided a boss 25 adapted to be capped by the part 26 of the contact member 9, which may be given the shape of a hollow lid.

The electrical circuit of the lightning arrester element described above is the following:

The plate 3 makes contact, by its boss or thickened portion 4, with the lower part of the resistant block 6. The contact member 10 connects electrically the upper parts of the two resistant blocks 6 and 7. Further, the lower part of the resistant block 7 and the lower electrode of the discharger block 8 are connected by the contact member 9, while the upper electrode of the block 8 emerges from cover 1. The springs 11, 12 and 13 ensure the necessary contact pressure.

The members or covers 1 and 2 are formed on their periphery with semi-cylindrical notches 27 serving to locate them upon insulating rods 28, visible in Fig. 4, which traverse the holes 5 in the plate 3. The electrical terminals of the lightning arrester element thus constituted are formed by the plate 3 and the electrode 14 of the discharger block 8. If there is superposed on this

3

element an identical element, its base plate (corresponding to the plate 3) will rest upon the electrode 14, thus establishing contact with the latter. In order to constitute the lightning arrester, there will be stacked in this way the necessary number of elements, in relation to the service voltage. Fig. 5 shows a longitudinal section of an improved lightning arrester according to the invention, in which figure there have been represented only the two upper and lower elements, the members represented in Figs. 3 and 4 being here designated by the same references.

The improved lightning arrester is shown contained in a hollow cylindrical insulator 29 to the extremities of which are fixed, by means of sealing material 30, two cylindrical sleeves 31 and 32. The sleeve 32 is welded to another sleeve 33 fast with a sole-plate 34 serving to support the apparatus. The insulator 29 is closed at its extremities by cover-plates 35 and 36 with elastic gaskets 37.

The upper cover-plate 35 is welded to the sleeve 31, while the plate 36 is fixed to the sleeve 32 by bolts 38.

The different elements of the lightning arrester, constituted by the members represented in Fig. 3, lodged between members or covers 1 and 2, are threaded upon the three rods 28, which are made of insulating material. Each of these rods is provided at its extremities with screw-threaded portions 39 and 40, sealed in insulating material and serving for the fixing of plates 41 and 42 between which the stack of the lightning arrester elements is clamped.

The lower plate 36 comprises three sunken portions 43, of cylindrical shape, the internal walls of which are lined with rings 44 made of elastic material, surrounding a socket 45 in the interior of which there is slidable a cylindrical member 46 screwed upon the part 40 and serving to fix the plate 42 upon the rods 28.

The lightning arrester assembly rests upon the sockets 45, by the intermediary of stacks of elastic washers 47.

The upper cover-plate 35 is formed with an inverted cup 48 lined with elastic material 49 surrounding a socket 50 in the interior of which there is slidable a cylindrical part 51 fixed to the plate 41. The bottom of the socket 50 is likewise fitted with elastic material 52.

A spring 53, resting against the upper cheek-plate 35 and disposed internally of the cup 48, holds the assembled elements of the lightning arrester together by means of the plate 41. This spring is shunted electrically by flexible foils 54 in order to prevent the passage of current into the said spring, which would constitute an inductance.

The elastic fixing means described ensure the absorption of possible shocks which the lightning arrester might undergo in the course of its transport and its installation.

The terminals of the lightning arrester are constituted by the plates 34 and 35. The interior of the insulator 29, which is made gas-tight by the means described, is preferably filled with nitrogen.

What I claim and desire to secure by Letters Patent is:

1. A lightning arrester for a high voltage line, comprising a plurality of axially spaced elements stacked to form a column, each of said elements comprising a metallic plate, an insulating casing superposed on said metallic plate, a discharger block enclosed in said casing, a plurality of resistance blocks enclosed in said casing, said resistance blocks being disposed radially relative to each other and said discharger block and being made of a material having a resistivity varying with applied voltage, and means connecting said elements including means electrically connecting their respective blocks in series.

2. A lightning arrester for a high voltage line, comprising a plurality of axially spaced elements stacked to form a column, each of said elements comprising a metallic plate, an insulating casing superposed on said metallic plate, a discharger block enclosed in said casing, two

4

resistance blocks enclosed in said casing, said resistance blocks being disposed radially relative to each other and to said discharger block and being made of a material having a resistivity varying with applied voltage, the three blocks being disposed in a triangle and each having a longitudinal axis perpendicular to said metallic plate, and means for connecting elements including means electrically connecting their respective blocks in series.

3. A lightning arrester for a high voltage line, comprising a plurality of elements stacked to form a column, each of said elements including a metallic plate, an insulating casing superposed on said metallic plate, said casing comprising two symmetrical covers having radially spaced recesses on juxtapositioned faces thereof, a discharger block and a plurality of resistance blocks enclosed in said casing recesses, said resistance blocks being made of a material having a resistivity varying with applied voltage, and means connecting said elements including means electrically connecting their respective blocks in series.

4. A lightning arrester for a high voltage line, comprising a plurality of elements stacked to form a column, each of said elements comprising a metallic plate, an insulating casing superposed on said metallic plate, a discharger block enclosed in said casing, two resistance blocks enclosed in said casing, the casing having an opening, means establishing electrical contact between said metallic plate and said blocks through said opening in said casing, the two said resistance blocks having upper surfaces, means connecting together electrically said upper surfaces, the other of said blocks having a lower surface connected electrically to a lower surface of said discharger block, means electrically connecting said lower surfaces, and said discharger block having an upper electrode emerging through said casing for making electrical contact with a superposed element.

5. A lightning arrester for a high voltage line, comprising a plurality of elements stacked to form a column, each of said elements comprising a metallic plate, an insulating casing superposed on said metallic plate, a discharger block enclosed in said casing, two resistance blocks enclosed in said casing, said casing having an opening through which one of said resistance blocks makes electrical contact with said metallic plate, a contact member connecting upper surfaces of said resistance blocks electrically, another contact member connecting the lower surface of the other resistance block to the lower surface of said discharger block, an electrode on the upper surface of said discharger block, and said metallic plate and the last-mentioned electrode forming electrical connections for other elements of said stack.

6. A lightning arrester for a high voltage line, comprising a plurality of elements stacked to form a column, each of said elements comprising a metallic plate, an insulating casing superposed on said metallic plate, a discharger block enclosed in said casing, two resistance blocks enclosed in said casing, said casing having an opening through which one of said resistance blocks is in electrical contact with said metallic plate, a contact member connecting the upper surfaces of said resistance blocks electrically together, another contact member connecting the lower surface of the other resistance block to the lower surface of said discharger block, an electrode on the upper surface of said discharger block, and each of said elements having the electrode of its discharger block in electrical connection with the metallic plate of a superposed element of said stack.

#### References Cited in the file of this patent

#### UNITED STATES PATENTS

2,721,958 Pidoux ..... Oct. 25, 1955