

J. NADER.

BOTTLE WASHING MACHINE.

APPLICATION FILED APR. 8, 1909. RENEWED MAY 23, 1910.

978.623.

Patented Dec. 13, 1910.

4 SHEETS-SHEET 1.

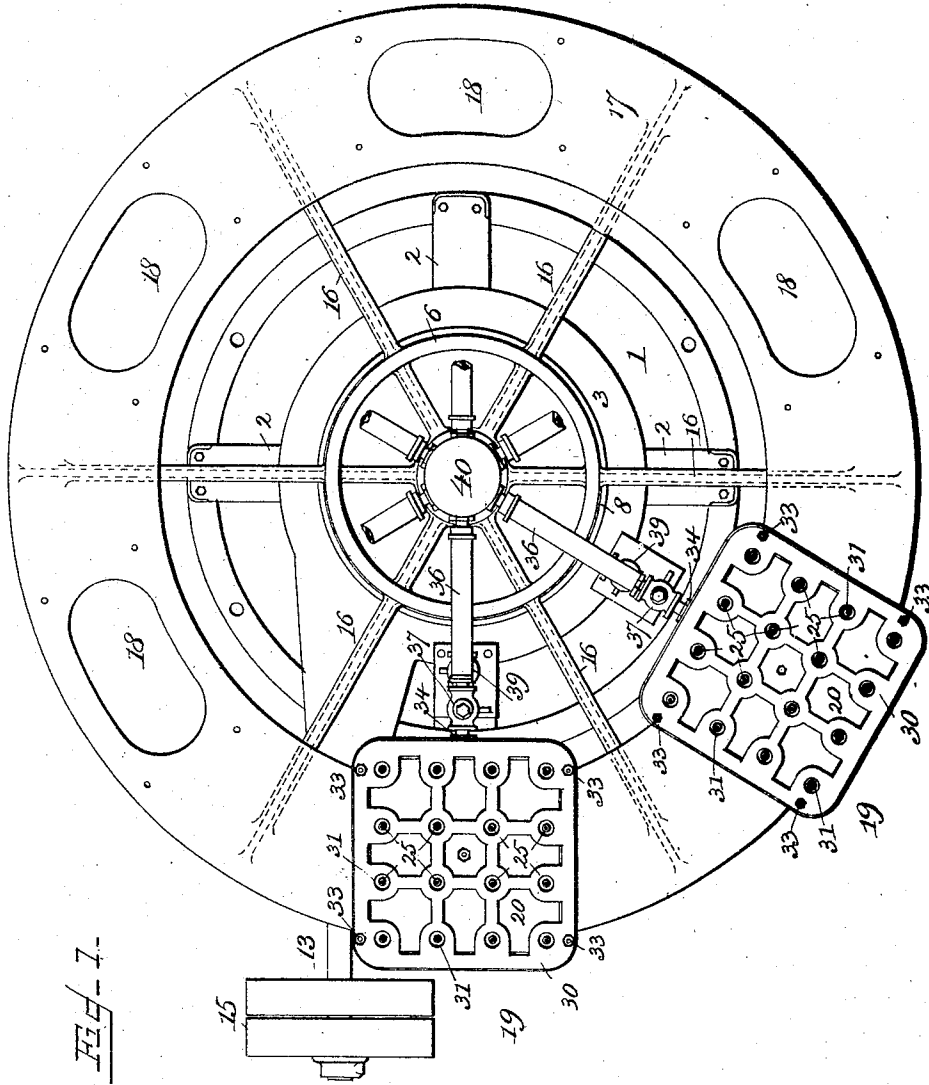

Witnesses

*F. L. Curand*

*C. A. Giesbauer*

Inventor

*Joseph Nader*

By

*A. B. Wilson & Co.*

Attorneys

J. NADER.

BOTTLE WASHING MACHINE.

APPLICATION FILED APR. 8, 1909. RENEWED MAY 23, 1910.

978,623.

Patented Dec. 13, 1910.

4 SHEETS—SHEET 2.

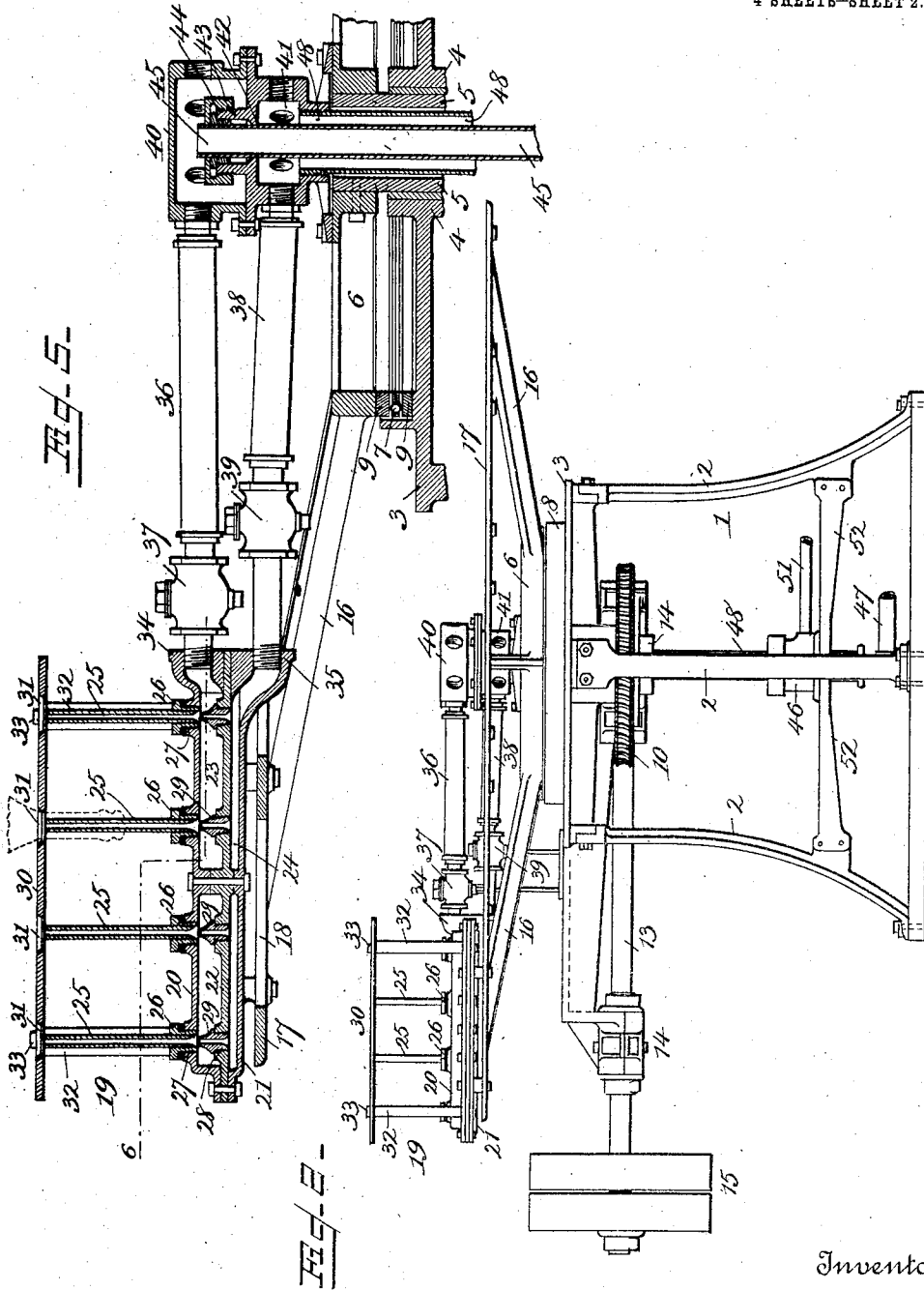

Witnesses

F. L. Ourand  
C. H. Giesbauer

Inventor

Joseph Nader

By *A. B. Wilson & Co.*

Attorneys

J. NADER.  
BOTTLE WASHING MACHINE.

APPLICATION FILED APR. 8, 1909. RENEWED MAY 23, 1910.

978,623.

Patented Dec. 13, 1910.

4 SHEETS—SHEET 3.

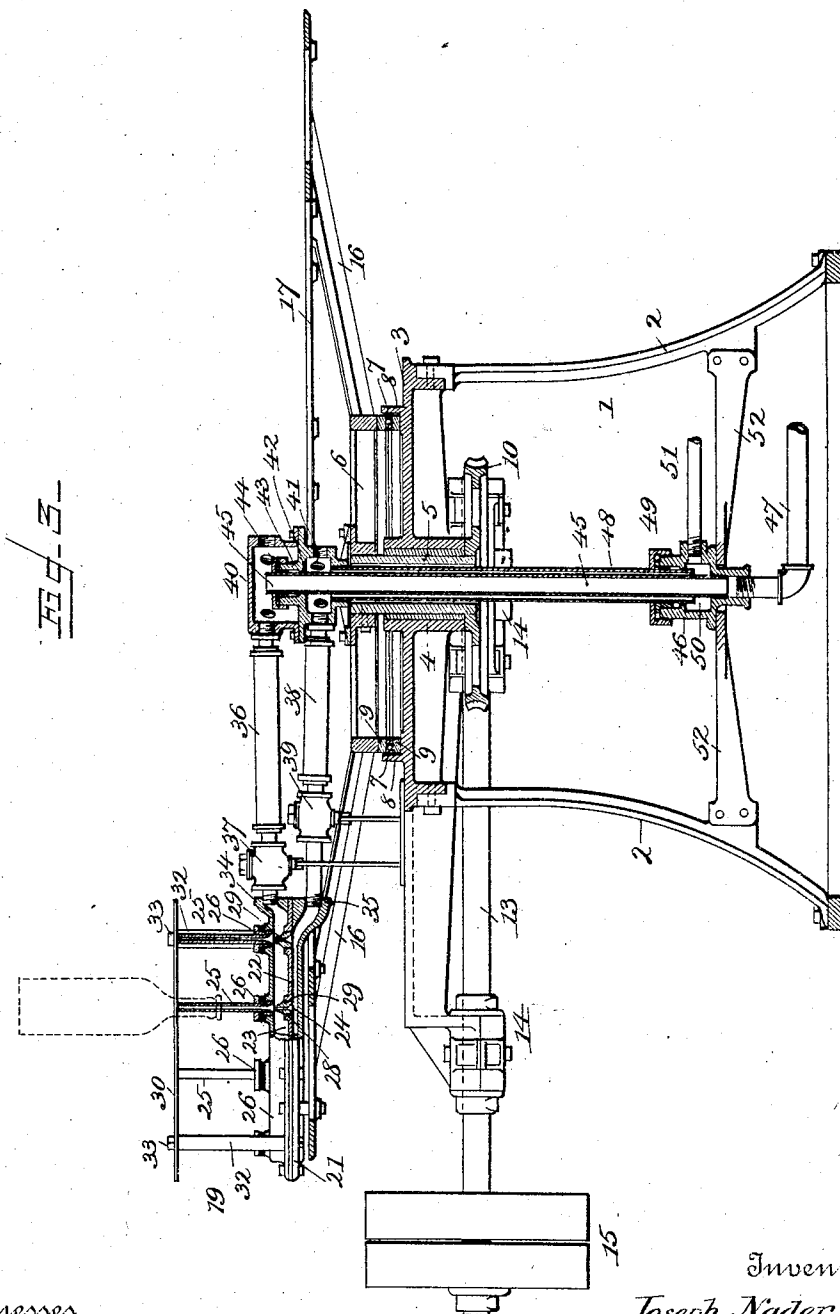

Witnesses  
F. L. Curand  
C. H. Gustauer

Inventor  
Joseph Nader  
By *A. B. Wilson & Co.*  
Attorneys

J. NADER.

BOTTLE WASHING MACHINE.

APPLICATION FILED APR. 9, 1909. RENEWED MAY 23, 1910.

978,623.

Patented Dec. 13, 1910.

4 SHEETS-SHEET 4.

Fig. 4.

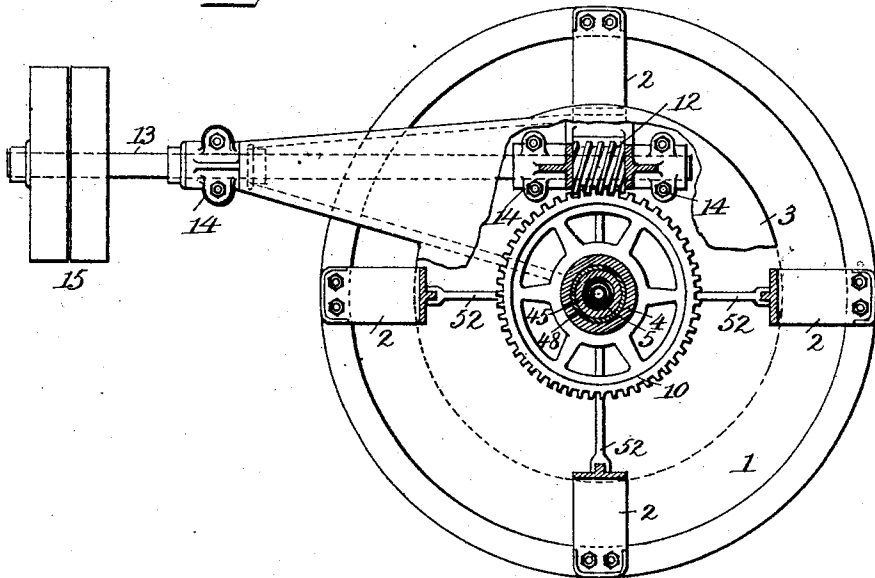
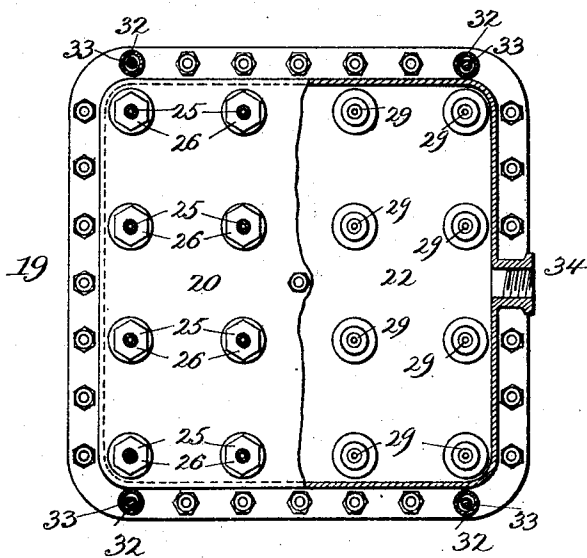

Fig. 5.



Witnesses

F. L. Curand  
C. H. Giesbauer

Inventor

Joseph Nader

By *A. B. Wilson & Co.*

Attorneys

# UNITED STATES PATENT OFFICE.

JOSEPH NADER, OF WAUKESHA, WISCONSIN.

## BOTTLE-WASHING MACHINE.

978,623.

Specification of Letters Patent. Patented Dec. 13, 1910.

Application filed April 8, 1909, Serial No. 488,659. Renewed May 23, 1910. Serial No. 562,999.

### *To all whom it may concern:*

Be it known that I, JOSEPH NADER, a citizen of the United States, residing at Waukesha, in the county of Waukesha and State of Wisconsin, have invented certain new and useful Improvements in Bottle-Washing Machines; and I do declare the following to be a full, clear, and exact description of the invention, such as will enable others skilled in the art to which it appertains to make and use the same.

This invention relates to improvements in bottle washing machines.

The object of the invention is to provide a machine of this character by means of which the wash water is forced into the bottles, and the latter thoroughly cleansed by means of compressed air, thereby dispensing with the use of brushes in the cleaning of the bottles.

A further object of the invention is to provide a bottle washing machine in which a large number of bottles may be simultaneously washed, and by which the amount of manual labor usually employed for this purpose will be greatly reduced, the operation simplified and the expense minimized.

With these and other objects in view, the invention consists of certain novel features of construction, combination and arrangement of parts as will be described and particularly pointed out in the appended claims.

In the accompanying drawing, Figure 1 is a plan view of a washing machine constructed in accordance with the invention, parts being broken away and in section; Fig. 2 is a side elevation of the same; Fig. 3 is a central vertical sectional view; Fig. 4 is a horizontal sectional view through the supporting frame and on a line with the driving mechanism; Fig. 5 is a detail sectional view on an enlarged scale of one of the compressed air and water discharging heads; and Fig. 6 is a horizontal sectional view of one of the water and air discharging heads taken between the bottle supporting plate and the upper side of the head, parts of said upper side being broken away to show the arrangement of the compressed-air discharging nipples.

Referring more particularly to the drawings, 1 denotes a supporting base or frame comprising supporting legs, 2, on the upper ends of which is secured a table, 3. In the table 3 is formed a central, vertically-disposed bearing, 4, in which is revolubly

mounted a tubular shaft, 5, on the upper end of which is mounted a turntable, 6, the outer edge of which travels and is revolubly supported on an annular series of bearing balls, 7, arranged in a suitable race-way, 8, on the table, 3. The lower edge of the turntable, 6, and the race-way 8 are provided with wear plates, 9, which bear directly upon the bearing balls, 7. On the lower end of the tubular shaft 5 is fixedly mounted a worm gear, 10, with which is engaged a worm, 12, on the end of a drive shaft, 13, which is revolubly mounted in suitable bearing brackets, 14, secured to the supporting frame and table of the machine. On the outer end of the shaft, 13, are mounted drive pulleys, 15, whereby power is applied to operate the machine.

The turntable, 6, is preferably in the form of an open circular frame, on the outer rim of which is formed a series of radially-projecting, upwardly-inclined supporting arms, 16, on the outer ends of which is formed an annular supporting plate or ring, 17, in which are formed, at equidistant points, elongated or elliptically-shaped passages, 18.

There may be any desired number of passages, 18, formed in the plate, 17, and over each of said passages is arranged a water and air discharging head, 19, said heads being bolted or otherwise rigidly secured to the ring or plate, 17. The water and air discharging heads, 19, are preferably in the form of a rectangular hollow body, formed of upper and lower plates, 20 and 21, and an intermediate or partition plate, 22, which separates the body portion into upper and lower compartments, 23 and 24. The upper compartment, 24, forms a water compartment, while the lower compartment is adapted to receive compressed air.

In the upper plate, 20, of the head, 19, is formed a series of discharging tubes, 25, which project upwardly from the head and are secured by suitable bushings, 26, in threaded apertures, 27, formed in the plate, 20. There may be any suitable number of discharge tubes for each head, and they are preferably arranged or spaced equidistant apart thereon. In the partition plate, 22, below each of the openings, 27, in the upper plate, 20, is formed a threaded opening, 28, and in said openings are screwed air discharging nipples, 29, the openings of which are immediately below the passage in the discharge tubes, 25, whereby when a cur-

rent of compressed air passes through said nipples and discharge tubes, a stream of water from the water compartment, 23, will be drawn through said tubes and forcibly ejected from the upper ends thereof.

Above the upper ends of the discharge tubes, 25, is arranged a bottle rack, which is preferably in the form of a plate, 30, having formed therein a series of openings, 31, one of which is arranged above each of the discharge tubes. The openings, 31, are adapted to receive the neck of the bottle, the mouth of which is passed over the upper open ends of the discharge tubes, the latter projecting up into the bottle, as clearly shown in dotted lines, 3, on the drawing. The plate, 30, is supported in operative position above the tubes, 25, by means of tubular supporting sleeves, 32, through which and through the plate, 30, and the outer edge of the heads, 19, are arranged tie bolts, 33.

On the inner edge of the heads, 19, are formed couplings, 34 and 35. With the coupling, 34, is connected the outer end of a branch water pipe, 36, in which is arranged a cut-off valve, 37. With the coupling, 35, is connected the outer end of a branch air pipe, 38, in which is arranged a cut-off valve, 39. The couplings, 34, and 35, communicate respectively with the water compartment 23 and the air compartment, 24, of the heads.

The inner ends of the branch water pipes, 36, are connected to a water distributing head, 40, which is bolted on and has a fluid-tight engagement with a similar air distributing head, 41, arranged on and secured to the turntable 6. In the upper wall of the air distributing head, 41, is formed a centrally-disposed passage, 42, surrounded by an upwardly projecting annular flange, 43, on which is arranged a stuffing box or gland, 44, through which projects the upper end of a tubular water supply pipe, 45, the lower end of which is engaged with a hollow coupling, 46, to which is connected a main water supply pipe, 47.

In the lower wall of the hollow air distributing head, 41, is formed a threaded passage in which is screwed the upper end of a tubular air conducting pipe, 48, which surrounds the water conducting pipe, 45, and has its lower end in engagement with the hollow coupling member, 46. On the upper end of the coupling, 46, is arranged a stuffing box or gland, 49, whereby a fluid-tight engagement is provided between the pipe, 48, and said coupling. The coupling, 46, is provided with a chamber, 50, in which the lower end of the pipe 48 extends, and with which is connected a water supply pipe, 51, which communicates with an air compressor or other source of supply (not shown). By means of the driving gear hereinbefore described, the turntable, 6, and the head supporting plate, 17, carried thereby are re-

involved and the bottles arranged on said heads are successively brought under a suitable shower bath or other washing mechanism, whereby the outsides of the bottles are cleaned. The outside cleaning mechanism forms no part of the present invention and is therefore not shown or described. In the revolution of the turntable and the parts carried thereby, the inner or water supply pipe, 45, remains stationary in the coupling, 46, the packing gland, 41, in the distributing head, 40, providing a fluid-tight engagement between said pipe and the revolving parts engaged therewith. The outer air supply pipe, 48, has a revolving fluid-tight engagement with the coupling, 46, provided by the packing gland, 49, and said pipe turns with the revolving parts of the machine. The coupling member, 46, is held in position and supported by means of radially-disposed braces, 52, the outer ends of which are secured to the supporting legs, 2, of the base.

In the operation of the machine, the compressed air when forced through the nipples, 29, into the tubes, 25, draws the water from the water compartment, 23, and ejects the same into the bottles arranged on said discharge tubes with sufficient force to thoroughly cleanse the same on the inside, thus dispensing with the brush usually employed for this purpose. The amount of water and the pressure of air supplied to the heads, 19, may be regulated by means of the cut-off valves, 37 and 39, arranged in the water and air pipes of the machine.

From the foregoing description, taken in connection with the accompanying drawing, the construction and operation of the invention will be readily understood without requiring a more extended explanation.

Various changes in the form, proportion and the minor details of construction may be resorted to without departing from the principle or sacrificing any of the advantages of the invention as defined in the appended claims.

Having thus described my invention, what I claim as new and desire to secure by Letters-Patent, is:

1. In a machine of the character described, a supporting base, a turntable revolubly mounted thereon, water and air discharging heads carried by said turntable, means whereby water and air are separately supplied to said heads, means whereby the bottles to be washed are supported on said heads, and means whereby streams of water and compressed air are simultaneously injected into said bottles to cleanse and rinse the same.

2. In a machine of the character described, a supporting base, a turntable revolubly mounted thereon, a series of water and air discharging heads carried by said turntable; said heads comprising a water compartment

and an air compartment, means whereby water and air are supplied to the respective compartments, discharging tubes arranged on said heads, means to support the bottles 5 on said tubes, and air discharging nipples arranged in said air compartment below each of said tubes, whereby a current of compressed air is discharged through each of said tubes, and a stream of water from 10 said water compartment forced thereby into said bottles to cleanse and rinse the same.

3. In a bottle washing machine, a series of combined water and air discharging heads, said heads having separate water and 15 air compartments, a series of discharge tubes connected with said water compartment and adapted to be inserted into the bottles to be washed, a rack to hold said bottles in position on said tubes, a series of air-injecting 20 nipples connected with said air compartment and adapted to force currents of compressed air through said discharge tubes and to thereby force a stream of water from said water compartment through each of said 25 tubes and to forcibly inject said water into the bottles, and means to regulate the supply of water and the pressure of air to said discharge heads.

4. In a machine of the character described, 30 a supporting base, a turntable revolubly mounted on said base, means whereby said table is revolved, an annular supporting plate arranged on said turntable, a series of combined water and air discharging heads 35 arranged on said plate, separate water and air compartments in said heads, water and air supply pipes arranged through said turntable, branch water and air pipes to connect said supply pipes with the water and air 40 compartments in said heads, means whereby the water is forcibly ejected from said water compartment by the compressed air from said air compartment, and means whereby said compressed air and water is supplied 45 to the bottles to cleanse the same.

5. In a bottle washing machine, a supporting base, a turntable revolubly mounted on said base, means whereby said turntable

is revolved, a series of combined water and air discharging heads carried by said turntable, water and air supply pipes arranged 50 in said base and projecting through said turntable, independent water and air compartments on the upper ends of said pipes, valved branch water and air supply pipes 55 connecting said distributing heads with respectively water and air compartments whereby the water and air is kept separated until discharged, means in said heads whereby the air in said air compartment is caused 60 to forcibly eject the water from said water compartment into the bottles, whereby the latter are thoroughly cleansed on their inner sides, and means to support a plurality of bottles in position on said heads to receive the water and air discharged therefrom. 65

6. In a bottle washing machine, a series of combined water and air discharging heads having separate water and air compartments, discharge tubes connected to said water compartment, and air discharging 70 nipples connected with said air compartment whereby a current of air discharged therefrom will force a stream of water from 75 said water compartment into said bottles.

7. In a bottle washing machine, a series of hollow combined water and air discharging heads having separate water and air 80 compartments, discharge tubes connected to said water compartments, air discharging nipples connected with said air compartment below said water discharging tubes whereby a stream of water is forced through said tubes from said water compartment, means 85 whereby water and air are respectively supplied to said compartments, and means to regulate said water and air supply.

In testimony whereof I have hereunto set my hand in presence of two subscribing witnesses. 90

JOSEPH NADER.

Witnesses:

WM. H. HARDY, Jr.,  
HENRY F. STOCK.