



US00D760874S

(12) **United States Design Patent**
Ball et al.

(10) **Patent No.:** **US D760,874 S**

(45) **Date of Patent:** **** Jul. 5, 2016**

(54) **HYDRANT ENCLOSURE**

(71) Applicant: **WCM Industries, Inc.**, Colorado Springs, CO (US)

(72) Inventors: **William T. Ball**, Colorado Springs, CO (US); **Eric Pilarczyk**, Colorado Springs, CO (US)

(73) Assignee: **WCM Industries, Inc.**, Colorado Springs, CO (US)

(**) Term: **14 Years**

(21) Appl. No.: **29/519,131**

(22) Filed: **Mar. 2, 2015**

(51) **LOC (10) Cl.** **23-01**

(52) **U.S. Cl.**

USPC **D23/259**

(58) **Field of Classification Search**

USPC D23/259, 233-237, 249, 260-263, 265, D23/266, 499; D24/129

CPC E03B 9/02; F16K 27/12; F16K 35/10; F16K 27/067; F16K 1/00; E03D 11/16; F16L 27/04; F16L 39/00; F16L 33/225; F16L 23/18; E21B 33/047

See application file for complete search history.

(56) **References Cited**

U.S. PATENT DOCUMENTS

D180,010	S *	4/1957	Britton et al.	D23/235
D216,791	S *	3/1970	Woodford et al.	D23/234
D228,554	S *	10/1973	Magorien et al.	D23/263
D245,255	S *	8/1977	Porter	D23/260
D275,616	S *	9/1984	Gray	D10/84
D283,204	S *	4/1986	McDonald	D10/96
D285,824	S *	9/1986	Anderson	D23/214
D318,718	S *	7/1991	Blatt	D13/133
5,964,246	A *	10/1999	Meeke	E03B 7/12 137/360
6,948,512	B2 *	9/2005	McKeague	E03B 9/04 134/168 C
D612,465	S *	3/2010	Salser	D23/266

D614,736	S *	4/2010	Freiler	D23/260
8,042,565	B2	10/2011	Ball et al.	
D656,223	S *	3/2012	Cronje	D23/233
8,353,309	B1 *	1/2013	Embry	A62C 35/20 137/382
D680,621	S *	4/2013	Foster	D23/233
D681,784	S *	5/2013	Liljegren	D23/262
D715,405	S *	10/2014	McAlpine	D23/233
D720,046	S *	12/2014	Morodomi	D23/233
D721,787	S *	1/2015	Yoshimura	D23/233
D721,788	S *	1/2015	Pifer	D23/233
D722,674	S *	2/2015	Lipkens	D23/207
D722,676	S *	2/2015	Gaertner	D23/233

(Continued)

OTHER PUBLICATIONS

Notice of Allowance for U.S. Appl. No. 29/514,306, mailed Apr. 24, 2015 10 pages.

(Continued)

Primary Examiner — John Windmuller

Assistant Examiner — Steven Czyz

(74) *Attorney, Agent, or Firm* — Sheridan Ross P.C.

(57) **CLAIM**

The ornamental design for a hydrant enclosure, as shown and described.

DESCRIPTION

FIG. 1 is a perspective view of the hydrant enclosure showing the new design;

FIG. 2 is a front elevation view thereof;

FIG. 3 is a rear elevation view thereof;

FIG. 4 is a right elevation view thereof;

FIG. 5 is a left elevation view thereof;

FIG. 6 is a top plan view thereof;

FIG. 7 is a bottom plan view thereof; and,

FIG. 8 is a perspective view thereof, wherein a door of the enclosure is shown in an open position.

The broken lines depict portions of the article that form no part of the claimed design.

1 Claim, 6 Drawing Sheets

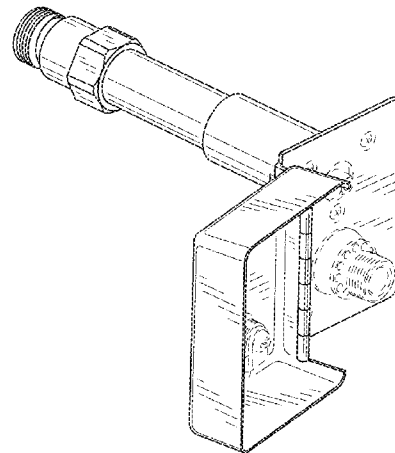
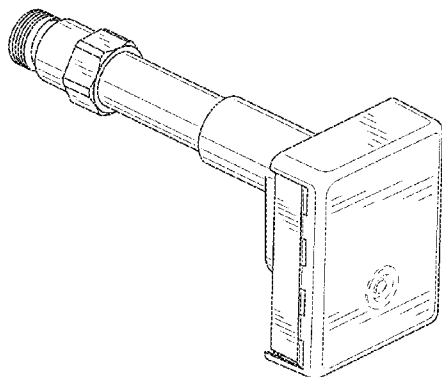

(56)

References Cited

U.S. PATENT DOCUMENTS

8,973,599	B2	3/2015	Stanaland	
D729,352	S *	5/2015	Ball	D23/259
D729,353	S *	5/2015	Ball	D23/259
D733,844	S *	7/2015	Ball	D23/259
D733,845	S *	7/2015	Ball	D23/259
D737,942	S *	9/2015	Ball	D23/259
2004/0000337	A1 *	1/2004	Cooper	A62C 37/50 137/377
2006/0086921	A1 *	4/2006	Ball	E03B 9/025 251/148
2011/0062834	A1 *	3/2011	Ball	A62C 35/20 312/215
2014/0202558	A1 *	7/2014	Chou	F16K 27/12 137/377
2015/0000767	A1 *	1/2015	Ball	E03B 9/025 137/382
2015/0240460	A1	8/2015	Ball et al.	

OTHER PUBLICATIONS

Notice of Allowance for U.S. Appl. No. 29/514,307, mailed May 7, 2015 7 pages.

Notice of Allowance for U.S. Appl. No. 29/514,308, mailed Jul. 7, 2015 7 pages.

U.S. Appl. No. 29/529,465, filed Jun. 8, 2015, Ball et al.

U.S. Appl. No. 29/503,651, filed Sep. 29, 2014, Ball et al.

U.S. Appl. No. 29/503,653, filed Sep. 29, 2014, Ball et al.

Notice of Allowance for U.S. Appl. No. 29/503,651, mailed Mar. 3, 2015, 10 pages.

Notice of Allowance for U.S. Appl. No. 29/503,653, mailed Mar. 4, 2015, 10 pages.

Official Action for U.S. Appl. No. 29/514,306, mailed Mar. 4, 2015, 9 pages.

Official Action for U.S. Appl. No. 29/514,307, mailed Mar. 11, 2015, 7 pages.

Official Action for U.S. Appl. No. 29/514,308, mailed Mar. 11, 2015, 7 pages.

U.S. Appl. No. 29/514,306, filed Jan. 10, 2015, Ball et al.

U.S. Appl. No. 29/514,307, filed Jan. 10, 2015, Ball et al.

U.S. Appl. No. 29/514,308, filed Jan. 10, 2015, Ball et al.

U.S. Appl. No. 29/519,956, filed Mar. 9, 2015, Ball et al.

U.S. Appl. No. 29/519,957, filed Mar. 9, 2015, Ball et al.

* cited by examiner

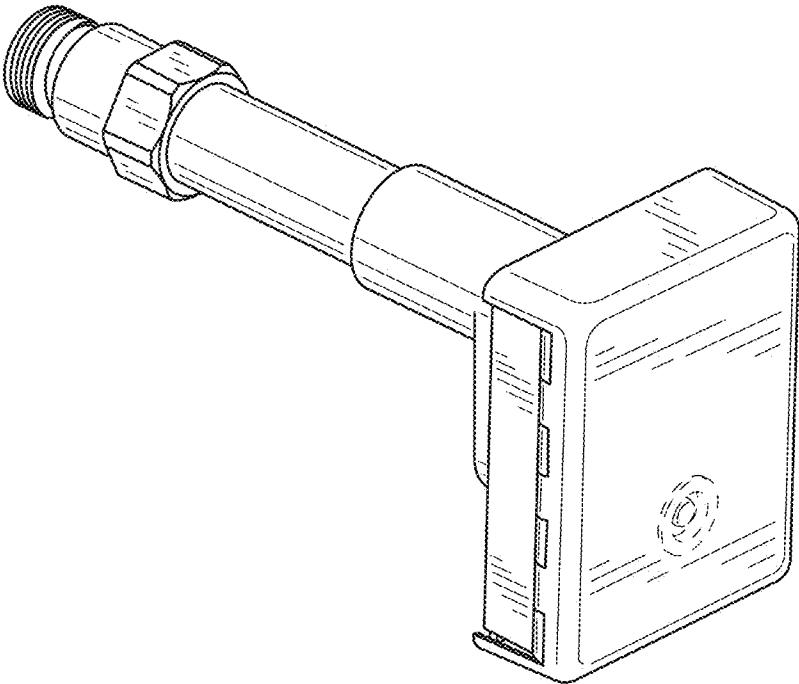

FIG.1

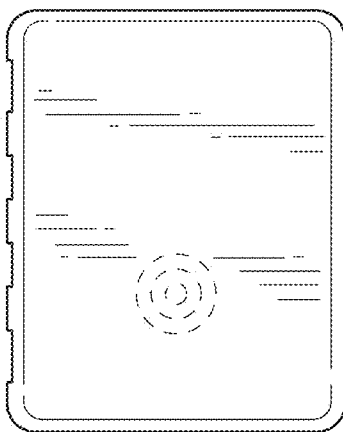

FIG. 2

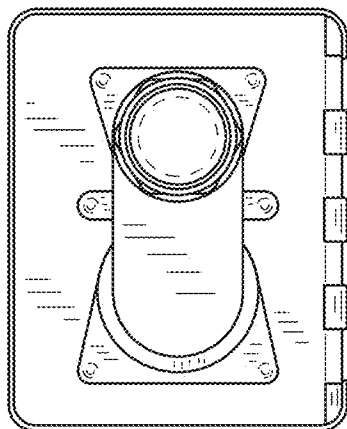

FIG. 3

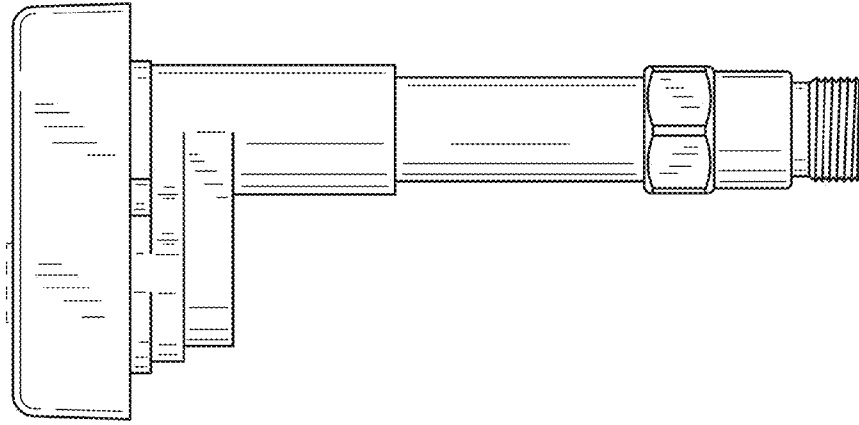

FIG. 4

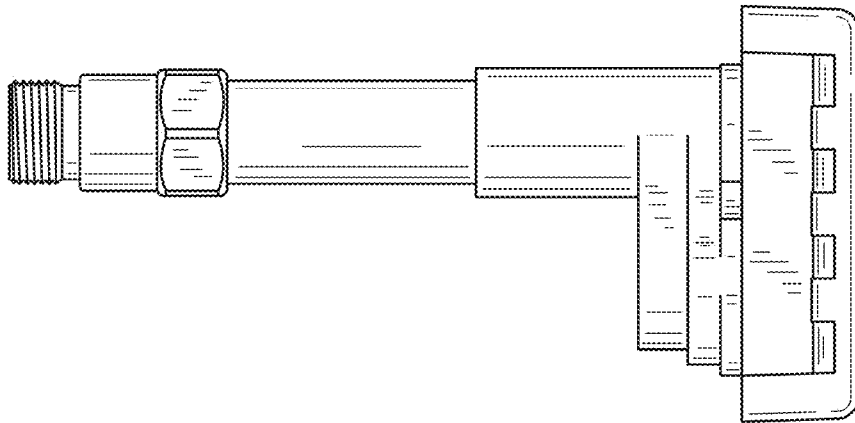

FIG. 5

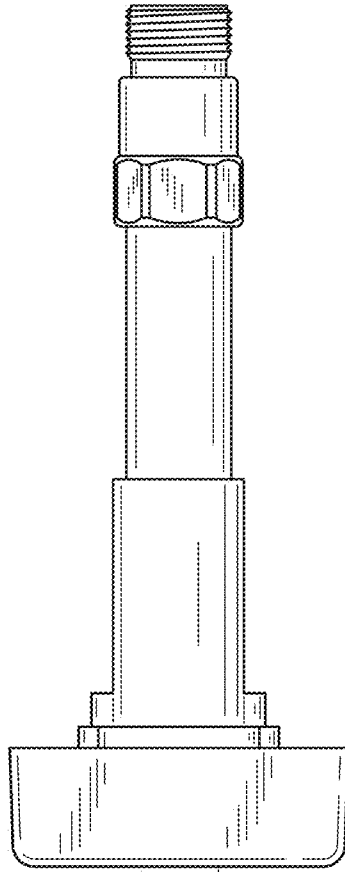

FIG.6

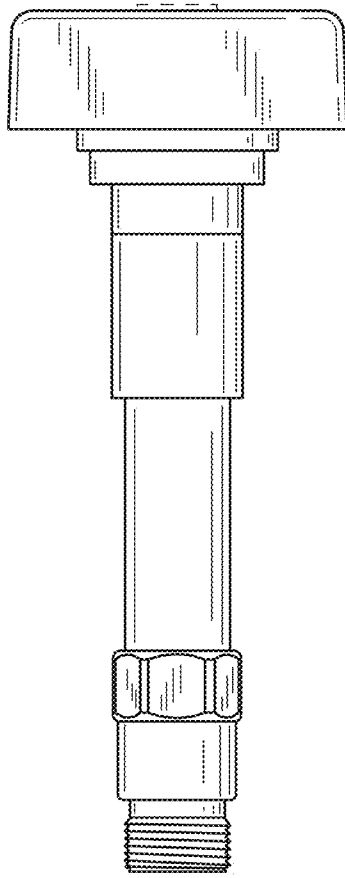

FIG.7

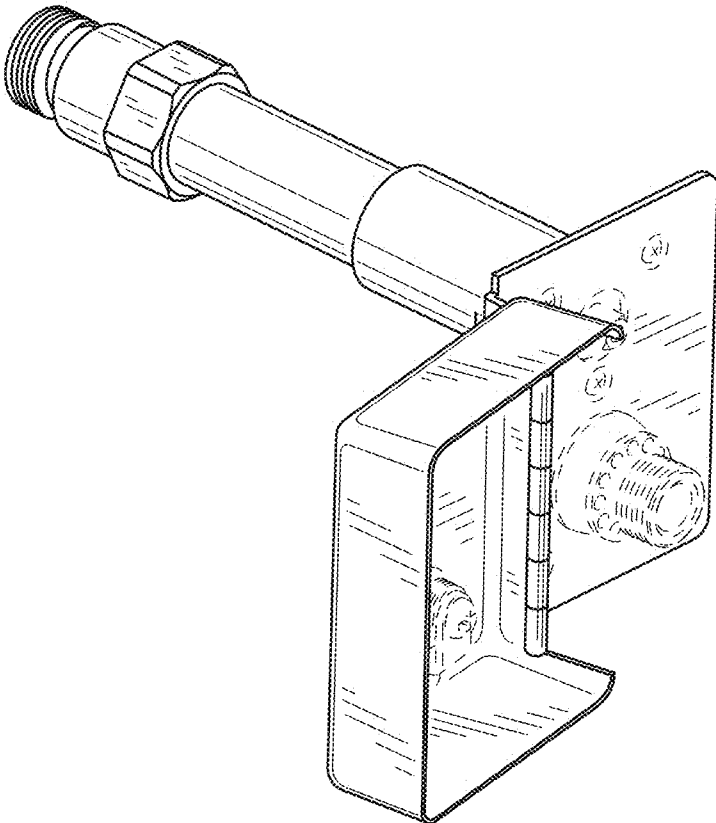

FIG.8